

PRIMA'S OFFICIAL STRATEGY GUIDE

Might and Magic® VI

THE MANDATE OF HEAVEN

DETAILED
MAPS!



NEW WORLD COMPUTING

Ted Chapman

Might and Magic VI

THE MANDATE OF HEAVEN

Ted Chapman



PRIMA PUBLISHING
Rocklin, California
(916) 632-4400
www.primagames.com



The Prima Logo and Prima Publishing ® are registered trademarks of Prima Communications, Inc.

© 1998 by Prima Publishing. All rights reserved. No part of this book may be reproduced or transmitted in any form or by any means, electronic or mechanical, including photocopying, recording, or by any information storage or retrieval system without written permission from Prima Publishing, except for the inclusion of quotations in a review.

Project Editor: Sara E. Wilson

The game *Might and Magic* is © 1986–1998 The 3DO Company. All rights reserved. New World Computing, the New World Computing logo, *Might and Magic*, and the *Might and Magic* logo are trademarks and/or registered trademarks of the 3DO Company. All other trademarks belong to their respective owners. New World Computing is a division of The 3DO Company.

All products and characters mentioned in this book are trademarks of their respective companies.

Important:

Prima Publishing has made every effort to determine that the information contained in this book is accurate. However, the publisher makes no warranty, either expressed or implied, as to the accuracy, effectiveness, or completeness of the material in this book; nor does the publisher assume liability for damages, either incidental or consequential, that may result from using the information in this book. The publisher cannot provide information regarding game play, hints and strategies, or problems with hardware or software. Questions should be directed to the support numbers provided by the game and device manufacturers in their documentation. Some game tricks require precise timing and may require repeated attempts before the desired result is achieved.

ISBN: 7615-1109-1

Library of Congress Catalog Card Number: 97-65823

Printed in the United States of America

98 99 00 BB 10 9 8 7 6 5

Contents

<u>Chapter 1</u>	Divinity: The Groundwork for The Mandate of Heaven. . . .	3
	A Legacy of Greatness	4
	The Story Line	12
	A Note from the Author	13
<u>Chapter 2</u>	Building a Winning Party	15
	The Character Classes	17
	Unusual Parties: Pros and Cons	23
<u>Chapter 3</u>	KNOW THINE ENEMY: Monsters	27
<u>Chapter 4</u>	Spells	89
	Fire Spells	92
	Air Spells	98
	Water Spells	104
	Earth Spells	110
	Spirit Spells	116
	Mind Spells	122
	Body Spells	128
	Light Spells	134
	Dark Spells	140

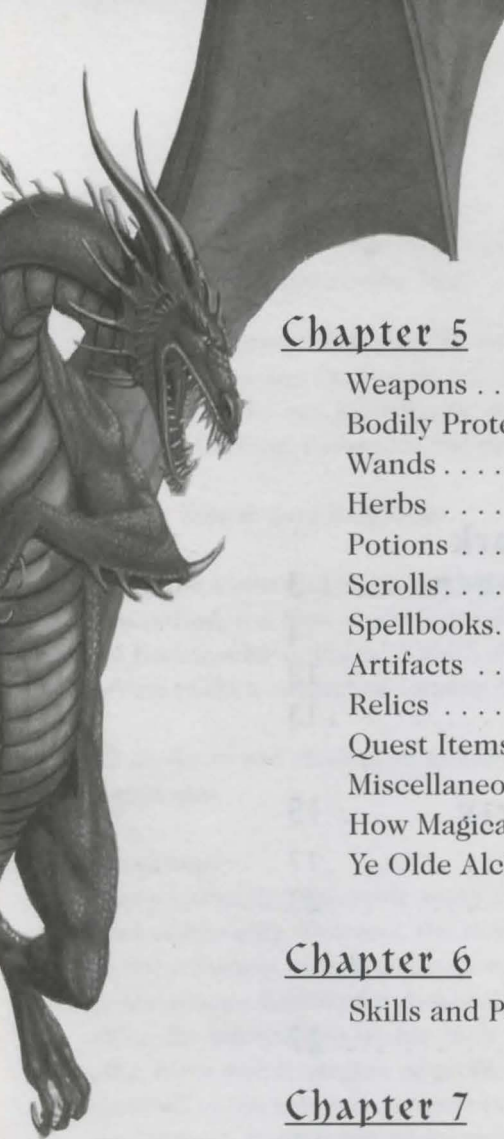

<u>Chapter 5</u>	Items	149
	Weapons	151
	Bodily Protection	172
	Wands	193
	Herbs	195
	Potions	196
	Scrolls	198
	Spellbooks	201
	Artifacts	204
	Relics	210
	Quest Items	216
	Miscellaneous Items	220
	How Magical Items are Generated	224
	Ye Olde Alchemical Shoppe	228
<u>Chapter 6</u>	Learning the Skills	233
	Skills and Prowess Adjustments	234
<u>Chapter 7</u>	The Pros and Cons of NPCs in Your Party	241
<u>Chapter 8</u>	Shoppes and Locations	247
	Map Grid	248
	Weapon Shoppes	249
	Armor Shoppes	251
	Magic Shoppes	253
	General Stores	255

CONTENTS

Stables	256
Ship Lines	258
Temples	260
Training Grounds	261
Magic-Users' Guild	262
Skill Training Centers	264
Skill Expertise and Mastery	265
Taverns	266
Banks	267
Dungeons	268
Castle Locations	270

Chapter 9 Essential Quests 273

The High Council Quest	275
Find Nicolai	284
Traitor Quest	285
Oracle Quest	287
Tomb of Varn Quest	293
Control Center Quest	298
Release Archibald Quest	298
The Hive Quest	300

Chapter 10 Important Quests 303

The Knight-to-Cavalier Quest	304
The Cavalier-to-Champion Quest	305
The Paladin-to-Crusader Quest	306
The Crusader-to-Hero Quest	308
The Archer-to-Battle Mage Quest	308
The Battle Mage-to-Warrior Mage Quest	310

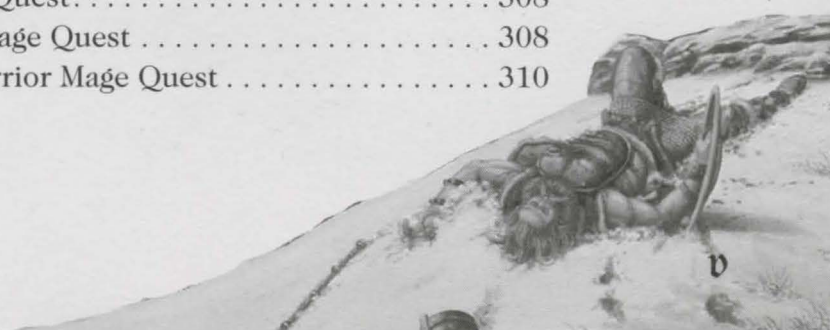

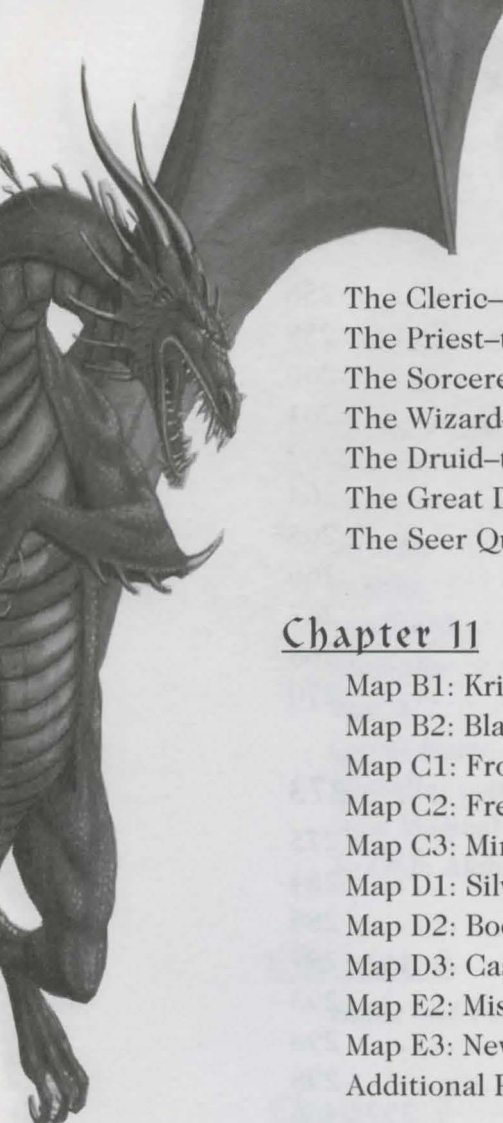

MI~~GH~~T & MA~~GI~~C VI The Mandate of Heaven
Official Strategy Guide

The Cleric-to-Priest Quest	310
The Priest-to-High Priest Quest	311
The Sorcerer-to-Wizard Quest	312
The Wizard-to-Arch Mage Quest	313
The Druid-to-Great Druid Quest	314
The Great Druid-to-Arch Druid Quest	315
The Seer Quest	316

Chapter 11 Minor Quests 319

Map B1: Kriegspire	320
Map B2: Blackshire	321
Map C1: Frozen Highlands	323
Map C2: Free Haven	323
Map C3: Mire of the Damned	324
Map D1: Silver Cove	325
Map D2: Bootleg Bay	326
Map D3: Castle Ironfist	328
Map E2: Misty Islands	328
Map E3: New Sorpigal	329
Additional Puzzles	332

Appendix The Cartographer's
Pantry: Maps 337

Outdoor Maps/Map Grid	338
---------------------------------	-----

Might and Magic[®] VI
THE MANDATE OF HEAVEN



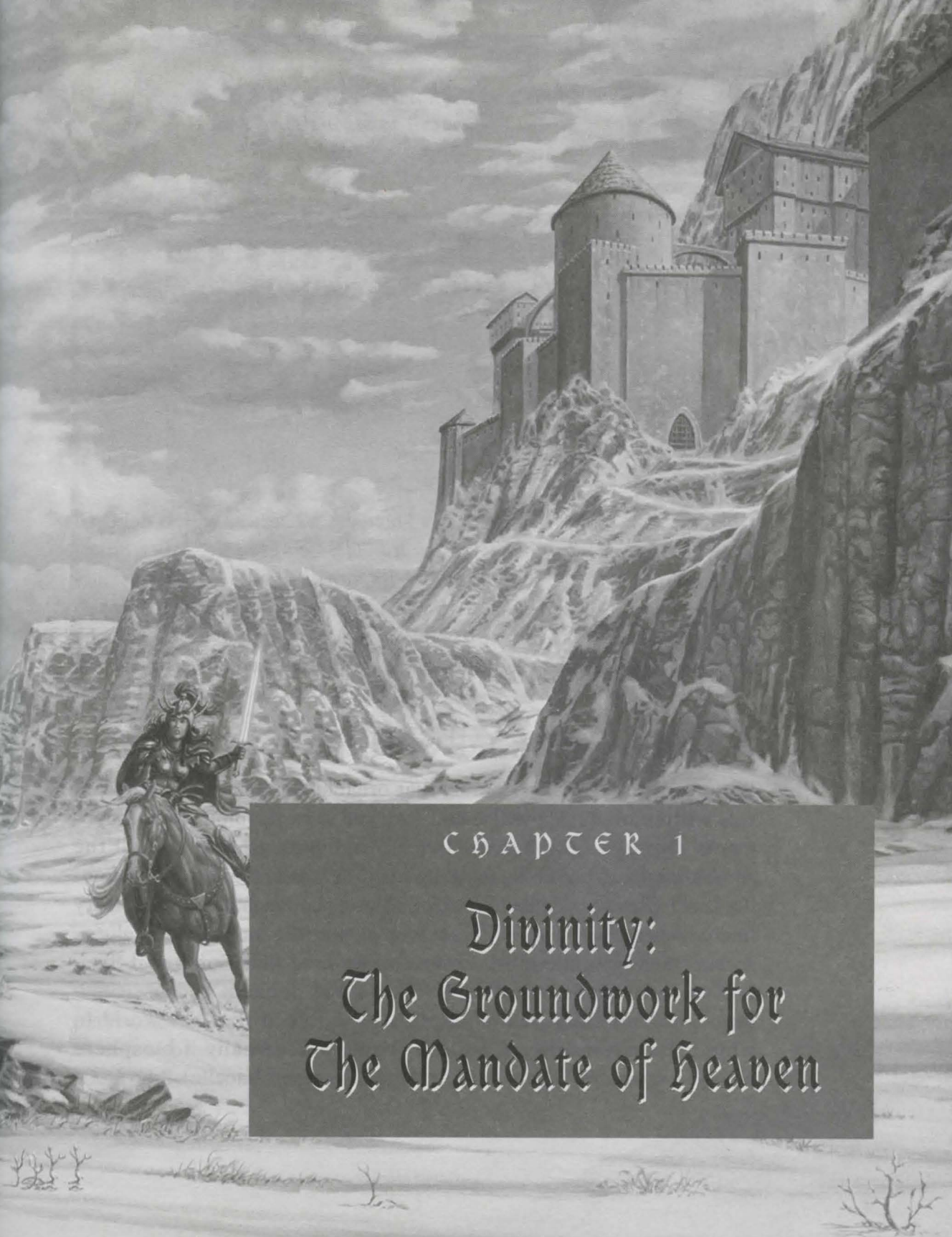

CHAPTER 1

Divinity:
The Groundwork for
The Mandate of Heaven



The Might and Magic game series, which debuted in 1984 with *Might and Magic, Book I: The Secret of the Inner Sanctum*, is one of the preeminent success stories in the computer role-playing game (CRPG) genre. Worldwide sales of the entire series is over 5 million units, and most gamers who were playing games in the early and mid-1980s remember fondly the series' first installment.

A LEGACY OF GREATNESS

By today's standards, of course, that original game is visibly dated. It was written on an Apple II-c and featured "eye-popping" EGA graphics. It required only 256 kilobytes of memory to run, and all the game's mapping had to be done by hand. It was one of the first (if not *the* first) games to feature first-person perspective gameplay. Its story line concerned a traveler, Corak, who sought the evil entity Sheltem. As the game progressed, the player discovered that Corak and Sheltem were androids, and that Corak hunted Sheltem because Sheltem's programming was faulty. It also unfolded that the world in which the adventure took place, Varn, was actually a biosphere aboard a spacecraft (Vehicular Astropod Research Nacelle).

CHAPTER 1 Divinity: The Groundwork for The Mandate of Heaven



D I V I N I T Y



Figure 1-1 The original map of the land of Varn, from the first *Might and Magic*

The second installment in the series, *Might and Magic II: Gates to Another World*, was a simple follow-up product, in the spirit of Shakespeare's "Henry IV, Part II": It gave those who played the original more of the same. The sequel implemented no new, earth-shattering features; as far as code was concerned, it could have been called "*Might and Magic 1A: More Secrets of the Inner Sanctum*." The player again sought the elusive Corak and Sheltem, but this time within another biosphere aboard the same spacecraft—Cron (Central Research Observational Nacelle).

MIGHT & MAGIC VI: The Mandate of Heaven

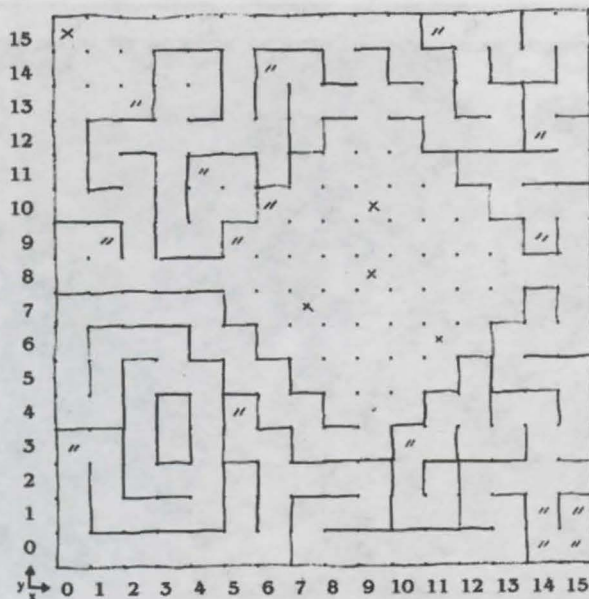
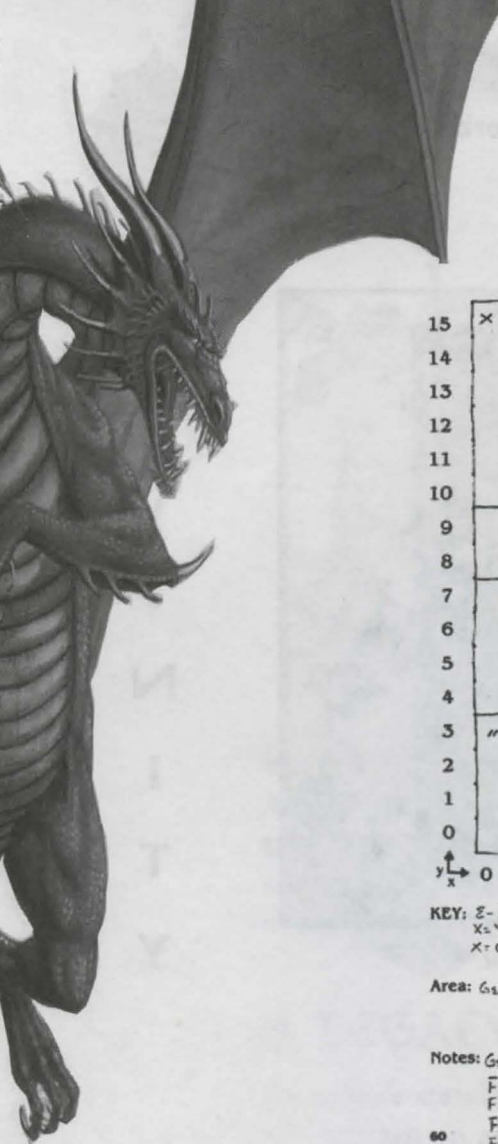

KEY: E-1
X=4,4-7
X=9,4-15

Area: GEMMAKER VOLCANO

Notes: GEMS (")
FIRE GLOVE +4: 11,6
FIRE SHIELD +4: 9,10
FLAMING SWORD +10: 9,8
FIRE SPEAR +4: 7,7

MIGHT AND MAGIC II

Figure 1-2 One of the author's hand-drawn maps from *Might and Magic II*

Part three of the *Might and Magic* series represented a quantum leap in ease-of-use. I, for one, am forever indebted to New World Computing for providing the automapping system that finally replaced hand-mapping. *Might and Magic III: Isles of Terra* upped the ante in terms of feature sets for all CRPGs of the time by providing VGA graphics and native sound card support.

CHAPTER 1 Divinity: The Groundwork for The Mandate of Heaven



D I V I N I T Y

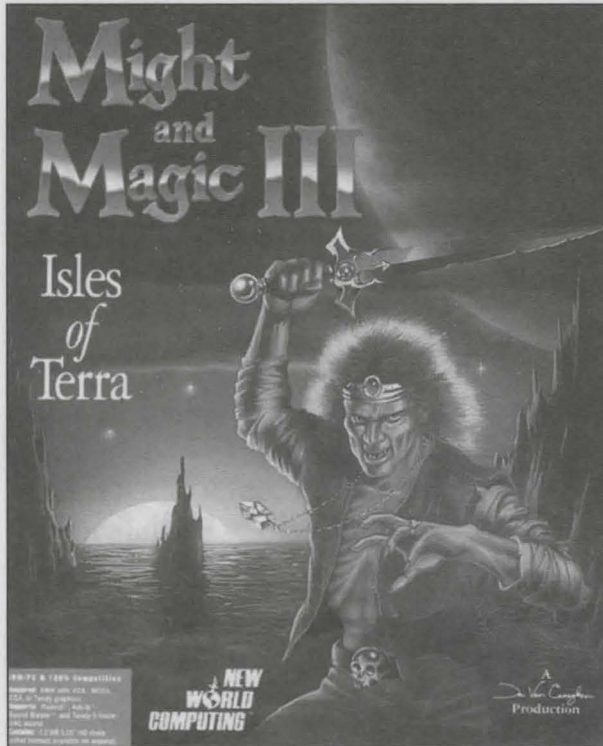

Figure 1-3 Running *Might and Magic III* required a lordly amount of memory—640K!

Isles of Terra immediately earned a number of industry awards, including the coveted “Role-Playing Game of the Year” award from *Computer Gaming World* magazine (1991). Having escaped once again from Corak’s clutches, Sheltem had caused six of the spacecraft’s biospheres to land on a planet called “Terra”; the portions of the biospheres that protrude above the surface of the planet’s vast ocean are known as “the Isles.” At the end of *Isles of Terra*, Sheltem escapes back to the mothership, with Corak—and the player—in hot pursuit.

MIGHT & MAGIC VI: The Mandate of Heaven

NOTE

It's amusing to note that the *de facto* sound standard of today, Sound Blaster® by Creative Labs, was listed third in the "Supports" line on the box (right behind Roland and AdLib). Things really have changed.

Another year passed as designers at New World Computing developed other games, but they ultimately focused on developing a new installment in the series. *Might and Magic IV: Clouds of Xeen* burst onto the gaming scene late in 1992 and immediately became a best-



Figures 1-4 Original artwork from *Might and Magic IV* and *V*

CHAPTER 1 Divinity: The Groundwork
for The Mandate of Heaven



D
I
V
I
N
I
T
Y

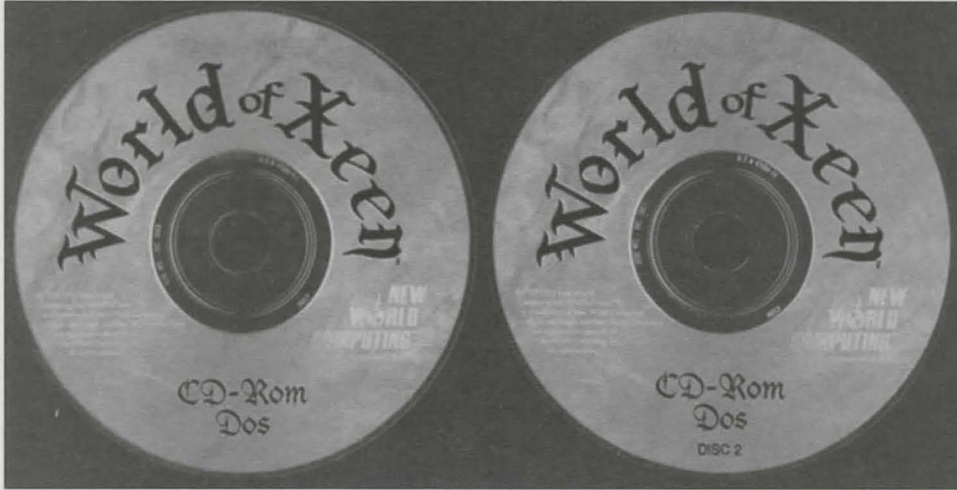
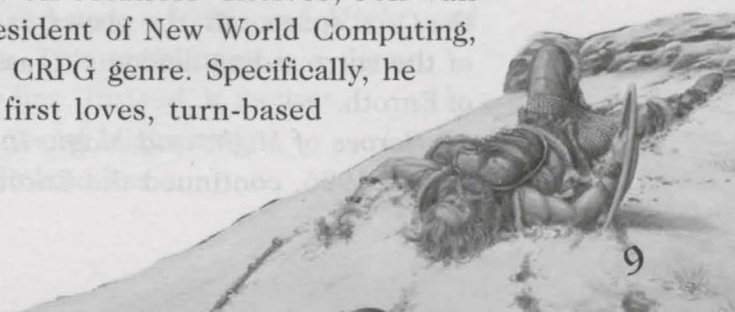

Figure 1-5 *Might and Magic: World of Xeen* was New World Computing's first double-CD set.

seller. The immensely popular *Might and Magic V: Darkside of Xeen* soon followed, and savvy players discovered that, if you installed both games on the same hard drive, you could play a bonus scenario called *World of Xeen*.

Developers included another short scenario expansion of *World of Xeen*—*Swords of Xeen*—in their *Might and Magic Trilogy*, a compendium of *Might and Magic III, IV, and V* (1996). In the Xeen (*Xylonite Experimental Environment Nacelle*) series, the player finally comes face to face with the evil Sheltem: You must defeat him—or die.

As *World of Xeen* stampeded off retailers' shelves, Jon Van Caneghem, series creator and president of New World Computing, decided to take a hiatus from the CRPG genre. Specifically, he wanted to go back to one of his first loves, turn-based



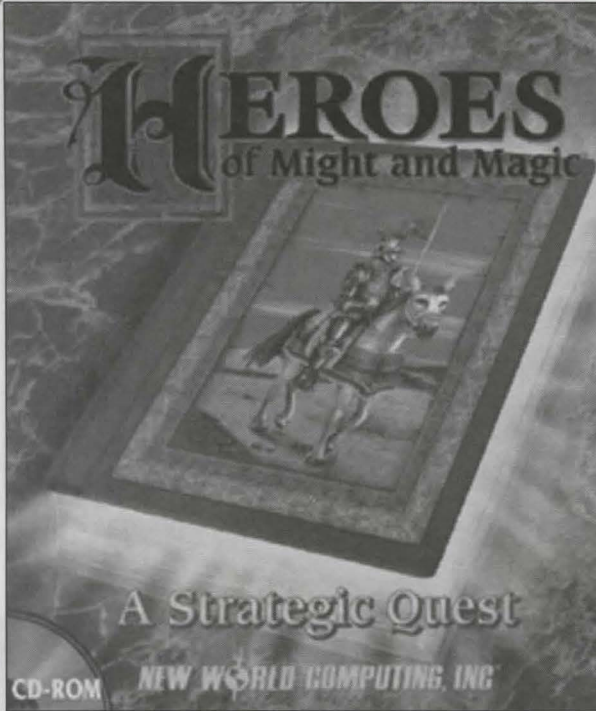

Figure 1-6 *The Heroes of Might and Magic series heralded New World Computing's new emphasis on strategy.*

strategy. Because the underpinnings of the Might and Magic story remained ripe with possibilities, he seized on the idea of developing a game that combined all its role-playing potential with combat tactics and adventuring strategy. Thus *Heroes of Might and Magic: A Strategic Quest* was born. In this facet of the sci-fi-meets-fantasy world of the Cron spacecraft, the player, as Lord Ironfist, must defeat the lords of the surrounding fiefdoms to assume the throne and rule the land of Enroth.

Heroes of Might and Magic II: The Succession Wars, introduced in late 1996, continued the Enroth saga in the strategy genre: Lord

CHAPTER 1 Divinity: The Groundwork for The Mandate of Heaven



D I V I N I T Y

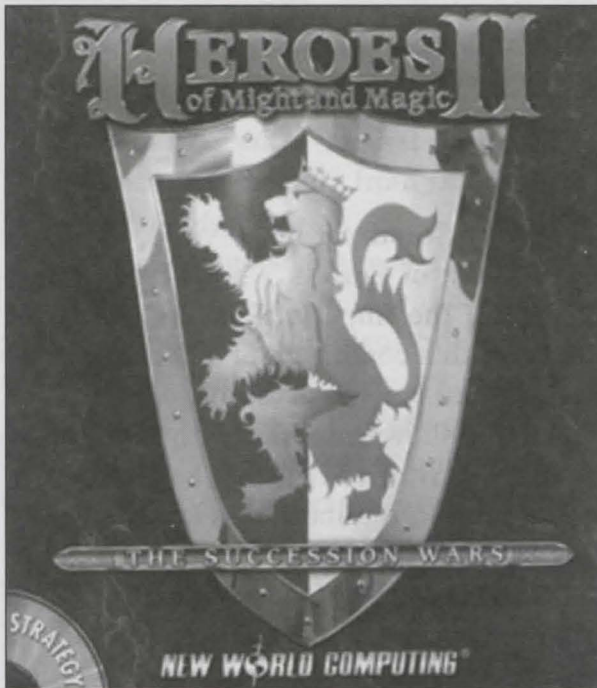
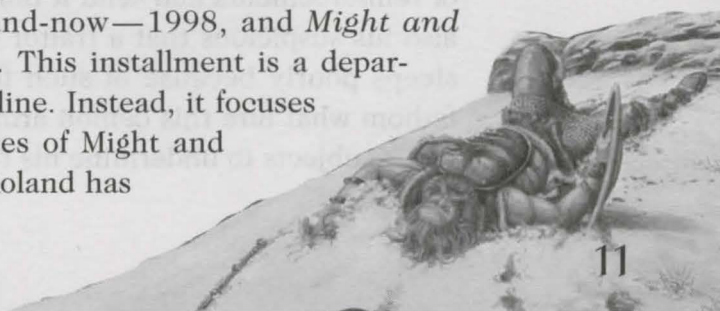

Figure 1-7 *Heroes of Might and Magic II* continued the Enroth saga.

Ironfist has died, and his two sons, Roland and Archibald, struggle for control of the throne. This sequel can be played from either son's perspective, with Roland assuming the role of the rightful heir, and Archibald that of the evil usurper. An add-on, *The Price of Loyalty*, gave *Heroes* fans more to cheer as they awaited the already-announced sequel to the original *Might and Magic* series.

Which brings us to the here-and-now—1998, and *Might and Magic VI: The Mandate of Heaven*. This installment is a departure from the Corak/Sheltem story line. Instead, it focuses on the plot developed in the *Heroes of Might and Magic* series: In lieu of exile, King Roland has



decided to have Archibald turned to stone. And so begins our newest tale . . .

THE STORY LINE

King Roland, safely on the throne of Enroth for many years, sets forth from his stronghold in the southeast of Enroth. A week prior, news arrived that Lord Kilburn, head of the Imperial Rangers, had gone missing and was presumed dead. With a contingent of 500 men behind him, Roland rides for the northwestern reaches of his kingdom.

Loving townspeople greet him, showering him with admiration and praise, as he passes through territories near his seat of power. However, as he nears the area where Lord Kilburn was last seen alive, his subjects are increasingly agitated and wary. A sudden summer snowstorm assails the party as they approach the town of Rockham, and they encounter a flood of refugees near the town of Edenbrook: Villagers there claim an army of devils marches on their position from the northwest.

King Roland's initial encounters with this army are successful; his men slay hundreds of demons before the hellspawn army turns tail. Roland orders a pursuit, but his army fails to overtake the devils. Calculating their possible tactics, Roland ambushes them, cutting across their probable path and felling more of this devilish army.

However, demon reinforcements already are arriving in Enroth, and their numbers are overwhelming. Ordering a retreat, Roland falls back to a castle formerly occupied by a Necromancer to wait out the siege: His last, urgent missives to his wife ask her to organize an army of reinforcements and send it north as soon as possible. He mentions also his suspicions that a traitor exists among his ranks, and that he sleeps poorly because of such fears. Roland, a popular king, can't fathom what lure this demon army could hold that would inspire one of his subjects to undermine his rule.

CHAPTER 1 Divinity: The Groundwork
for The Mandate of Heaven



D
I
V
I
N
I
T
Y

A NOTE FROM THE AUTHOR

Corak has moved on, Sheltem safely in tow. *Might and Magic VI: The Mandate of Heaven* is the first of the series involving an entirely new story line, taken directly from the myths and legends around *Heroes of Might and Magic*.

Although some series fans almost certainly will miss the original story line, the fact is, New World Computing became uncomfortable with the increasing implausibility of the science fiction plot as it unfolded in a fantasy framework: The effort to suspend disbelief had become a Herculean task to ask of gamers.

So, then, welcome—not only to the first new *Might and Magic* installment in over three years, but to a new direction in which to spin a new tale. Newcomers to the award-winning *Might and Magic* games are about to embark on a flight of fantasy from which they'll not soon return. And I wish those new to the *Heroes* series Godspeed on their journey into the heart of King Roland's domain. Finally, to those who find themselves here through either path, I hold open the gates of New Sorpigal and bid you enter. I promise you will not be disappointed.

—Ted Chapman





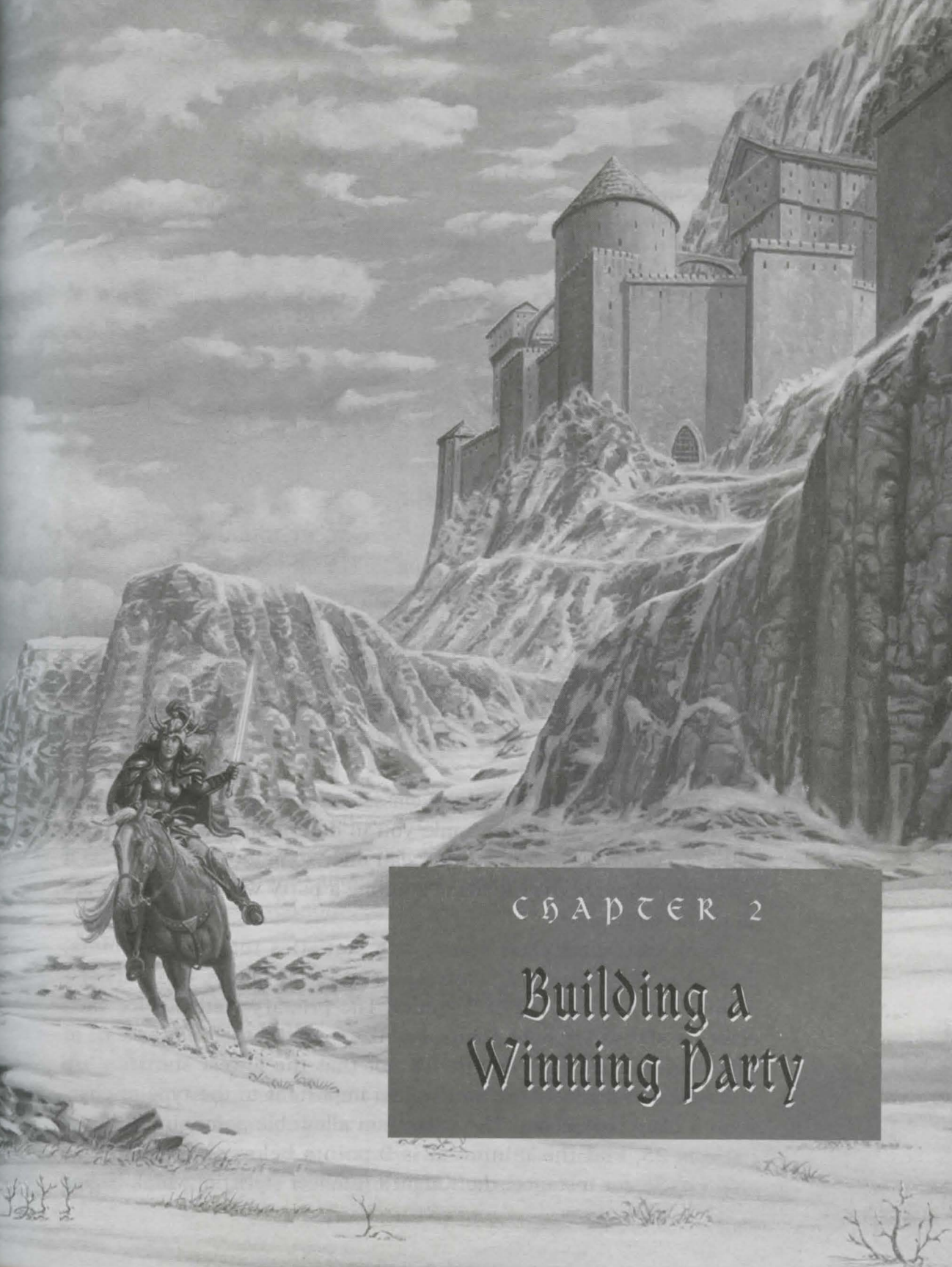

CHAPTER 2

Building a
Winning Party



There are many combinations of the six character classes you can use for adventuring in *The Mandate of Heaven*. The default party is acceptable, and most players find the combination of Paladin–Archer–Cleric–Sorcerer appealing. After all, they begin with an assortment of fighting styles, both ranged and melee, and the party, although initially lacking in spells and skills, can become a formidable weapon with proper training. However, some players, seeking a greater challenge, may opt to begin with a party made up entirely of Sorcerers or Druids.

This section describes all the classes, including the strengths and weaknesses of each. I can't guide you in determining the party most suited to your playing style, but I can offer some broad guidance. I'll also cover some of the pitfalls of running a party whose members are all in the same class.

Each character class starts with statistics totaling 73 points, divided as two stats of 14 points, two stats of 11 points, two stats of 7 points, and one stat set of 9 points. The primary statistics for each class are always set at 14 points, and the statistics that matter least to that class are set to 7 points. It's not that the lowest statistics are unimportant; it's just that they're less important to the type of character a class represents. The maximum allowable points in each statistic is 25, and the minimum is 2 points below the initial base amount. So, for instance, the Knight's Intellect statistic, which begins



CREATE PARTY

Sir Roderick Paladin	Alexis Archer	Serena Cleric	Zoltan Sorcerer
Might 14 Intellect 7 Personality 14 Endurance 11 Accuracy 11 Speed 9 Luck 7	Might 9 Intellect 14 Personality 7 Endurance 11 Accuracy 14 Speed 11 Luck 7	Might 7 Intellect 9 Personality 14 Endurance 11 Accuracy 11 Speed 7 Luck 14	Might 7 Intellect 14 Personality 9 Endurance 11 Accuracy 7 Speed 14 Luck 11
SKILLS Sword Spirit Magic None None	SKILLS Bow Air Magic None None	SKILLS Mace Body Magic None None	SKILLS Dagger Fire Magic None None
CLASS Knight Paladin Cleric Archer Sorcerer Druid		Available Skills Dagger Shield Perception Spear Leather Diplomacy Mace Chain Disarm	
			Bonus Pts - 50 +

at 7 points, can be reduced to 5 points or increased to 25 points. When you create your party, keep in mind that the statistics can be reduced, allowing you to allot additional points in areas that you may feel warrant extra attention.

THE CHARACTER CLASSES

Knight

The Knight character class is your general, all-purpose fighter. The class's primary statistics are Might and Endurance, with Speed and Accuracy as secondary elements. The Knight can't learn the ways of magic, and therefore

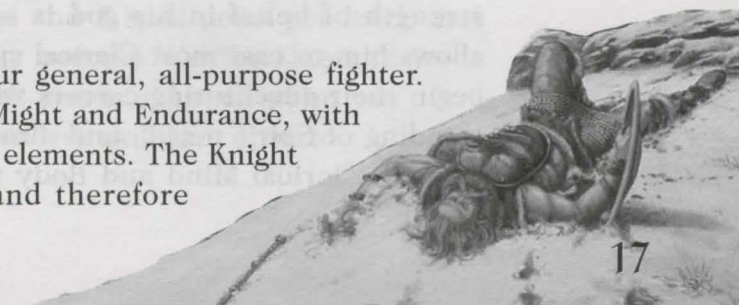

can't learn or cast spells from a spellbook. Thus, his Intelligence and Personality statistics are set to the lowest initial stats (7). However, the Knight can learn the Perception skill.

All weapon and armor skills are ultimately available to the Knight, and he can eventually pick up all the secondary skills (except Meditation). The toughest warriors of all the classes, Knights begin with the greatest number of hit points and get the greatest number of hit points when they advance in level. Knights can be promoted to Cavalier status with a 2 hit point per level gain, and then to Champion status, with another 2 hit point per level gain. What the Knight lacks in IQ and charm he more than makes up for in his brute-force approach to campaigning.

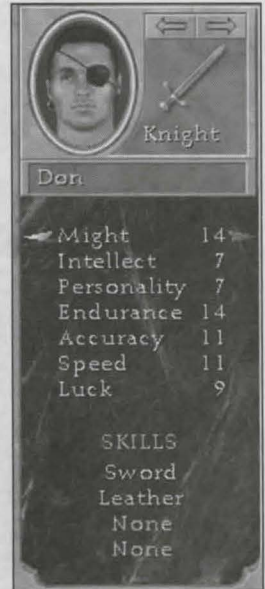

Don	
Might	14
Intellect	7
Personality	7
Endurance	14
Accuracy	11
Speed	11
Luck	9
SKILLS	
Sword	
Leather	
None	
None	

Paladin

A cross between Knights and Clerics, Paladins perform both roles well, but not as well as the more focused classes they borrow from. Like the Knight class, the Paladin eventually can be trained to use any weapon or armor type, although their initial weapon and armor skills choices are somewhat more limited.

The Paladin is a “holy warrior” whose strength of belief in his god is so powerful it allows him to cast most Clerical spells. Paladins begin their adventuring careers with an understanding of Spirit magic, and also can learn to use the Clerical Mind and Body realms. They

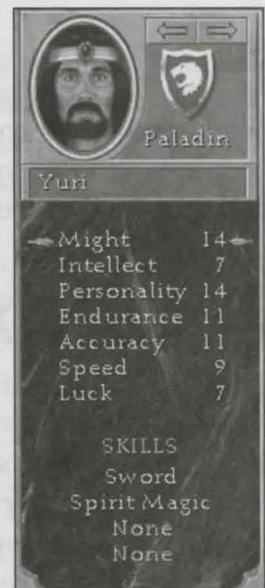

Yuri	
Might	14
Intellect	7
Personality	14
Endurance	11
Accuracy	11
Speed	9
Luck	7
SKILLS	
Sword	
Spirit Magic	
None	
None	



can't learn to use the greater magic realms of Light and Dark, however, nor any of the Elemental realms.

Paladins true to their cause may be promoted to Crusader (gaining 1 hit point and spell point per level) and ultimately to Hero (gaining another hit point and spell point per level). Paladins may learn all secondary skills.



Archer

Your primary weapon in long-range battles, the Archer character class is dedicated to the use of the Bow and the magic of Sorcery. Able to cast some (but not all) Sorcerer-class spells, the Archer is a small arsenal of distance-weapons tactics. The Archer's primary statistics are in Accuracy and Speed (but don't ignore the Intellect statistic).

Archers may learn to use any type of weapon (specializing in the Bow, of course), but they may never learn the Shield or Plate Armor skills. To compensate, they begin with Air magic and may learn to use the remaining Elemental realms eventually. The greater realms of Light and Dark are beyond their grasp, however.

Archers can ascend to Battle Mage (gaining 1 hit point and 1 spell point per level) and eventually may become Warrior Mages (gaining another hit point and spell point per level). All secondary skills are open to the Archer.



	
Archer	
Doris	
Might	9
Intellect	14
Personality	7
Endurance	11
Accuracy	14
Speed	11
Luck	7
SKILLS	
Bow	
Air Magic	
None	
None	

Cleric

In most adventuring parties, the Cleric is relegated to the role of healer. The Cleric's mighty faith allows him to call on the power of his god, and the most skilled Clerics can heal almost any wound and cure any affliction instantly. To become a Cleric, the petitioner must forswear using bladed weapons.

Clerics in *The Mandate of Heaven* are adventuring, spellcasting holy men. A Cleric is a mediocre fighter but an excellent spellcaster,

with spells that focus on healing and defense.

Clerics can learn

from the Mirrored Path of the Light and the Dark, and the awesome spells these realms of magic offer. They are, unfortunately, limited in their weapons; Mace, Staff, and Bow are their only choices. Armor is a little better, with only Plate forbidden them. They have no restrictions in secondary skills. With much diligence and study, Clerics can be promoted to Priest (gaining 1 hit point and 1 spell point per level) and eventually to High Priest (gaining another hit point and spell point).



Cleric	
Dawn	
◀ Might	7 ▶
Intellect	9
Personality	14
Endurance	11
Accuracy	11
Speed	7
Luck	14
SKILLS	
Mace	
Body Magic	
None	
None	





Sorcerer

The Sorcerer is dedicated to using magic. The primary statistics for this character class are Intellect and Speed. Students of the realm of Elemental magic, Sorcerers concentrate on offensive and utilitarian magic.

Sorcerers are weak fighters, barely able to learn to use the dagger, the staff, and the bow effectively. They're forbidden any kind of armor or shield and have the lowest hit points of any class. Nonetheless, Sorcerers



	
Sorcerer	
Bart	
Might	7
Intellect	14
Personality	9
Endurance	11
Accuracy	7
Speed	14
Luck	11
SKILLS	
Dagger	
Fire Magic	
None	
None	

can wield mighty offensive spells and have access to the Mirrored Path of the Light and the Dark, source of the land's most powerful spells. With enough spellcasting experience, Sorcerers can ascend to Wizard (gaining 1 hit point and 1 spell point per level) and then to Arch Mage (gaining another hit point and spell point). No secondary skills are forbidden Sorcerers.

The Druid

Druids are a hybrid of Sorcerer and Cleric classes. They make poor fighters (better only than the lowly Sorcerer) and have relatively few hit points. On the positive side, Druids can learn spells from both the schools of Sorcery and Clerical magic. Tempering this, Druids are forbidden to learn spells from the Light

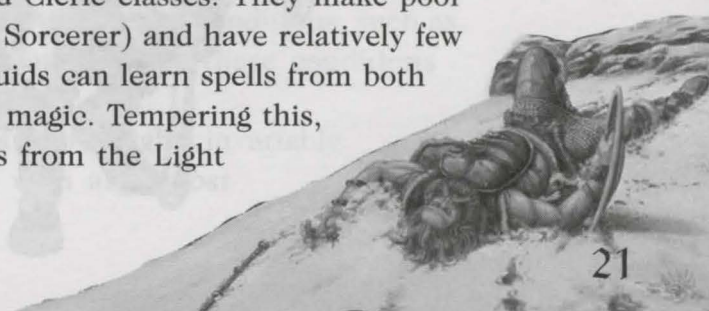

MIGHT & MAGIC VI: The Mandate of Heaven

and Dark paths, and their weapon skills encompass only Staff, Dagger, and Bow. Similarly, their armor skills are relegated to the lowly Leather and Shield.

All secondary skills are open to the Druid, and as a bonus Druids may begin the game with the Learning skill. Druids can ascend to Great Druid (gaining 1 hit point and 1 spell point per level) and eventually to Arch Druid (gaining another spell point and hit point per level).



Druid

Floyd

Might	7
Intellect	14
Personality	14
Endurance	11
Accuracy	7
Speed	11
Luck	9

SKILLS

Staff	
Earth Magic	
None	
None	





UNUSUAL PARTIES: PROS AND CONS

Almost every player of *The Mandate of Heaven* will try out the default party of Paladin–Archer–Cleric–Sorcerer, but a few hardy souls will try some of the more esoteric party combinations.

Five Days, Four Knights in Fabulous Enroth

Running a party made up entirely of Knights is extremely foolhardy, but it's perhaps the game's greatest challenge. Without access to innate spellcasting abilities, this party must rely heavily on scrolls, potions, and temples to succeed. When creating this party, make certain at least two of the Knights get their Intelligence and Personality stats increased to at least 14 apiece, and then split the remaining points as evenly as you can among the four between Speed and Accuracy stats. In terms of skills, make sure all four Knights begin with the Bodybuilding skill, and then assign two of the Knights (the two with less-than-stellar Intelligence and Personality) the Shield skill. Assign the remaining two Knights the Perception and Disarm Traps skills. When it becomes available, all four Knights should immediately learn the Bow skill.

The downside of running a party like this is that you'll need access to all the gold you can scrounge. Your party inevitably will fall victim to poisons, disease, and the like, and obtaining gold is the only way you can afford the temples' expensive treatments. Because even the slightest unfortunate condition will cause grievous harm left untreated, you'll spend a lot of time running back and forth to towns and temples. Potions are a quick fix for most mild conditions, such as poisoned or diseased, but more serious cases of these conditions can only be cured at a temple.

On the positive side, though, a party of Knights invariably can take out close-range enemies with an almost unnatural ease.

Spellcaster Goulash: Sorcerers, Clerics, and Druids

Running a party of all spellcasters is tough at first. No matter how you generate the party, the spells novice spellcasters can wield are extremely limited. Compounding your problems are the facts that (a) new spells are expensive, and (b) you don't have a lot of gold.

This doesn't mean you shouldn't try, however.

To be effective, any Clerics in the party should get their Might stat boosted to at least 11; Sorcerers and Druids need a balance of Accuracy and Might. When assigning skills, make sure all initial schools of magic are well-represented, and give your frontline fighters some decent armor skills, if possible.

The positive side of this type of campaigning should be obvious: You can inflict moderate damage from ranged positions, while finishing off stragglers at close quarters. The downside is that almost every enemy you encounter in the game has some type of ranged attack, so you'll need to be like Jack—both nimble and quick.

Heavy Artillery: A Gaggle of Archers

Archers can be the most confounding of all character classes, and only expert players should even bother attempting to run a party made up exclusively of them. The problem stems from the Archers' learning deficiency in melee combat. Bows are really ineffective against enemies who insist on getting in close.

In open arenas, however, Archers are peerless, able to take out even powerful enemies before they can get within sword range. When creating a party of Archers, I've found it's best to increase both their Accuracy and their Speed stats to 16, and then give your first two Archers' Might stat 5 points apiece (for a total of 14 Might). Your remaining two Archers should split the final 12 points—an extra 6 points of Luck to each. All Archers should receive the Leather skill,



and the two that have vacant skill slots should get either Fire Magic or the Perception skill.

Because Archers have no access to healing skills, plan on spending a lot of time going to temples. However, if you're particularly skillful, you can remain well out of range of most of the unnatural conditions (such as Poison or Disease), which tend to be touch-based.

Jihad: Your Own Private Holy War

A party of Paladins can be an amusing sight. Paladins tend to be headstrong and full of themselves, rushing into battle at the least provocation. Truly evil enemies (of which *The Mandate of Heaven* seems to have more than its fair share) send Paladins into cataleptic fits, and often what's left over afterward isn't recognizable.

However, Paladins aren't without their negative aspects. The most notable arise from their low Speed statistic. A slow Paladin is a dead Paladin, or at least a very injured Paladin, and for this reason a party of Paladins all should have their Speed stat increased to at least 12 each.

This is the only party that can safely ignore the Intellect statistic; Paladins are better off somewhat stupid. However, because each Paladin in such a party should get the Bodybuilding skill, trap damage isn't really much of a threat to their overall well-being. Paladins neither need nor want most sorcery combat scrolls, yet the elemental non-combat scrolls will prove very useful to them.

There are few pitfalls to running an entire party of Paladins, and the positive aspects of such a party are considerable. Oddly, this is one of the easiest party combinations to succeed with.





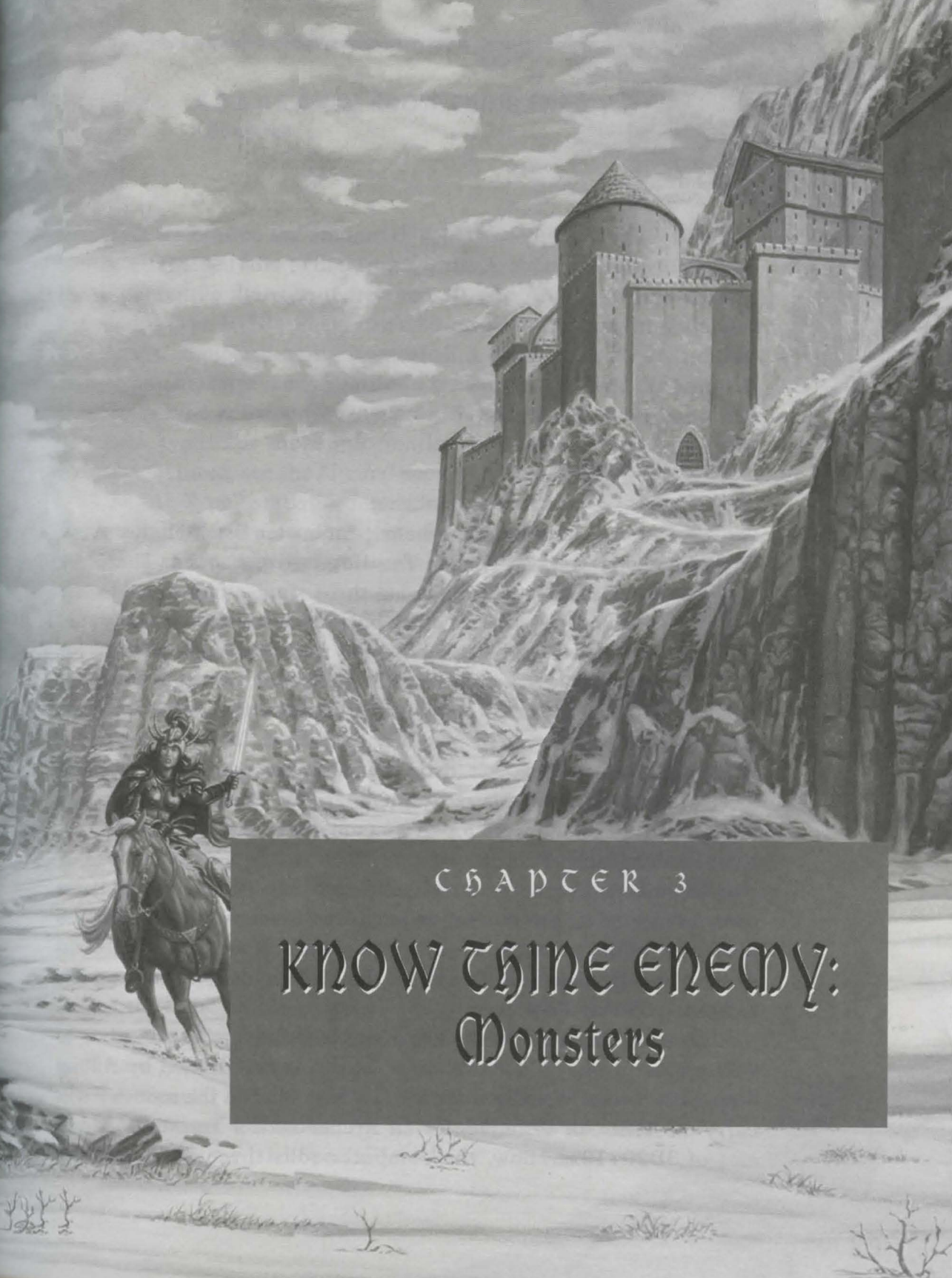

CHAPTER 3

KNOW THINE ENEMY:
Monsters



This comprehensive monster list includes every type of monster you can fight in *The Mandate of Heaven*. There are 57 basic aggregates, each comprising three similar monsters. In the game, these monsters vary in color but otherwise appear the same. Because this book is in black-and-white, we use a single picture for each monster aggregate and describe the color variation for each type. This section lists all monsters in alphabetical order by class, rather than the order you'll encounter them in.

The "Attacks as Level" statistic is what the monster's approximate level would be if it were a party member. For example, the Archer attacks as though she were a party member with nine levels of experience and training.

"Experience Earned" is a monster's total experience points. For a party of four adventurers, each person would receive 100 experience points for killing a monster worth 400 points. If it's not possible to divide the experience points evenly, the lead characters (reading left to right) gain the odd points.

"Treasure Carried" is usually a two-part figure. The number of gold pieces (if any) a dead monster carries is determined by rolling dice, as indicated. Usually there's also a base chance the monster will carry an item. For example, for an Archer with a Treasure Earned stat of $3D20+10\%L1Bow$, the computer rolls three 20-sided dice

CHAPTER 3 KNOW THINE ENEMY: Monsters



M O N S T E R S

(3D20) to determine the amount of gold carried, and then rolls a percentile (100-sided) die to determine if the Archer was carrying a Bow. If the percentile die rolls more than 10, the Archer carries nothing but gold. Level 1 (L1) items can't be magical, but anything beyond that has a chance of being magical. If a listed item shows no percentile, the monster always carries a treasure of the base type shown. If no item type is listed (for instance, 5%L4), the monster can carry any item type. For more information on magical items and how they're generated, see the "Items" section of this book (Chapter 5).

The "AI Type" statistic determines a monster's aggressiveness. The more aggressive an enemy is, the more likely it is to continue attacking even when it's heavily damaged. "Suicidal" monsters will attack until they're dead; "Aggressive" monsters will attack until their hit points have been reduced to 90%, then they will attempt to run away; "Normal" monsters will attempt to run away once their hit points have been reduced by 75%. "Wimp" monsters will attempt to run away when their hit points have been reduced by half.

"Attack Speed" is the amount of time a monster must spend recovering from its primary attack form. Secondary attacks are made at a attack speed of 1.5 times the normal Attack Speed.

If a monster has a "Preferred Enemy," it will continue attacking any party member of that character class, ignoring the others. If your party lacks a member of that class, the monster will attack as though it had no preferences. Note that some monsters have more than one preferred enemy. A few have a preferred enemy of "any x " (where x is a number), which means they prefer to attack multiple party members at the same time, and will always go after their preferred number of party members instead of concentrating on only one. Several monsters have gender preferences.

The "Special Attack" stat reflects the amount of additional damage the monster will inflict if it successfully hits its enemy. Some monsters have no Special Attack.

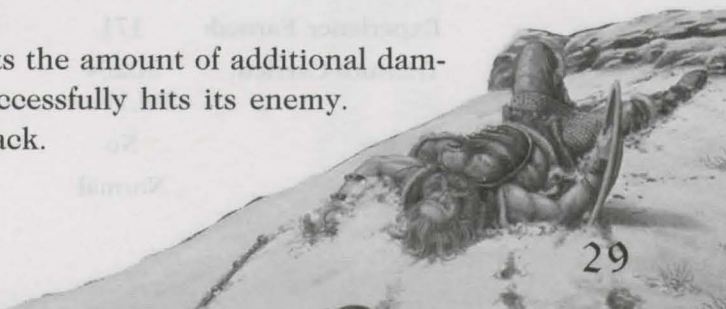

The stats for “PA Type,” “PA Damage,” and “PA Missile” dictate the primary method of attack. Attack types can be physical, magical, or elemental. Stats for “2A Type,” “2A Damage,” and “2A Missile” concern secondary attack methods, and these require the creature to make a percentile die roll at the beginning of each combat round to see if they’ll be used (“2nd Attack %”). Some monsters have no secondary attack, and if an entire monster group has no secondary method of attack, no statistics will be shown.

The “Spell Use %” statistic shows a monster’s chance of attacking or defending with a spell (if it is able to do so). Also, the Spell statistic dictates the spell the monster will attack or defend with. If a monster group doesn’t use spells, no statistics will be shown. Consult the “Spells” in Chapter 4 for more information on how a skill modifier works.

Some monsters are resistant to certain attacks. These resistances are the last statistic (“Resist”) for each monster type, and include Fire (F), Electrical (E), Cold (C), Poison (P), Physical (Ph), and Magic (M). The statistics are measured by the following criteria: “N” means no resistance to that form of attack, “SR” means some resistance, and “R” means resistant. “Imm” means a monster is immune to that form of attack.

Archer Class

STATISTIC	ARCHER	MASTER ARCHER	FIRE ARCHER
Attacks as Level:	9	19	29
Hit Points:	35	93	171
Armor Class:	14	16	22
Experience Earned:	171	551	1131
Treasure Carried:	3D20+ 5%L1Bow	10D20+ 5%L2Bow	10D100+ 10%L3Bow
Flying:	No	No	No
AI Type:	Normal	Aggressive	Aggressive

CHAPTER 3 KNOW THINE ENEMY: Monsters



M O N S T E R S

Preferred Enemy:	None	Archer	Archer
Special Attack:	0	0	0
PA Type:	Physical	Physical	Physical
PA Damage:	1D6+1	2D6+2	3D6+3
PA Missile:	Arrow	Arrow	Arrow
2nd Attack %:	0	10	10
2A Type:	0	Fire	Fire
2A Damage:	0	3D6	4D6
2A Missile:	0	Fire Arrow	Fire Arrow
Spell Use %:	0	0	10
Spell:	N/A	N/A	Fireball, Normal, 5
Resist:	F (SR), E (N), C (N), P (N), Ph (N), M (N)	F (SR), E (N), C (N), P (N), Ph (N), M (N)	F (R), E (SR), C (SR), P (SR), Ph (N), M (SR)



Barbarian Class

STATISTIC	MAGYAR	MAGYAR SOLDIER	MAGYAR MATRON
Attacks as Level:	14	25	37
Hit Points:	61	137	247
Armor Class:	16	22	28
Experience Earned:	336	875	1739
Treasure Carried:	10D10+ 5%L2Misc	10D20+ 5%L3Misc	10D100+ 10%L4Misc
Flying:	No	No	No
AI Type:	Aggressive	Aggressive	Suicidal
Attack Speed:	80	80	60
Preferred Enemy:	None	Sorcerer	Sorcerer
Special Attack:	0	0	0
PA Type:	Physical	Physical	Physical
PA Damage:	3D7+3	3D7+6	3D7+12
PA Missile:	0	0	0
2nd Attack %:	0	10	20
2A Type:	0	Physical	Electrical
2A Damage:	0	3D7+18	7D8
2A Missile:	0	0	Electrical
Resist:	F (SR), E (SR), C (SR), P (SR), Ph (N), M (N)	F (SR), E (SR), C (SR), P (SR), Ph (N), M(N)	F (R), E (R), C (R), P (R), Ph (N), M (N)

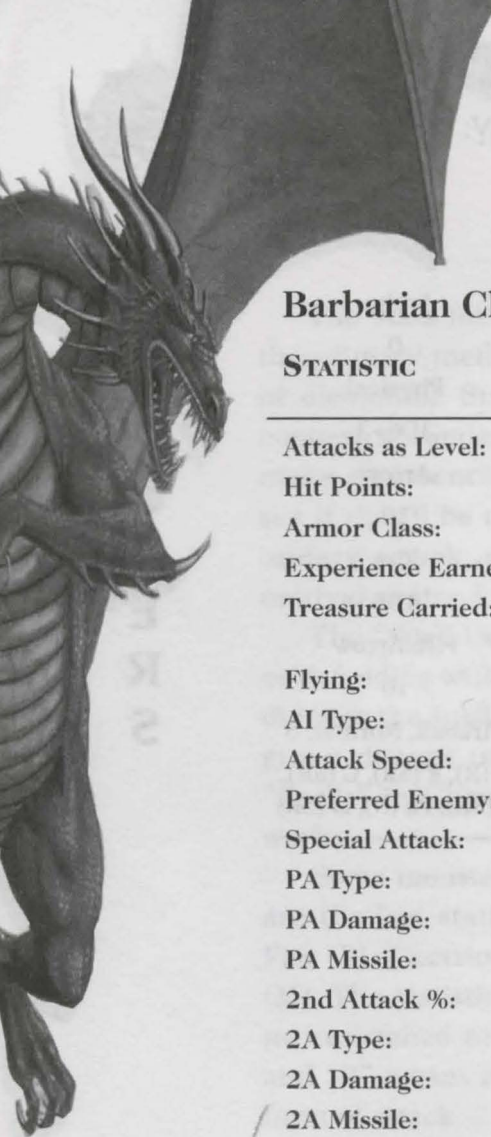

CHAPTER 3 KNOW THINE ENEMY: Monsters



M O N S T E R S

Bat Class

STATISTIC	BAT	GIANT BAT	VAMPIRE BAT
Attacks as Level:	3	6	9
Hit Points:	9	21	35
Armor Class:	5	8	10
Experience Earned:	39	96	171
Treasure Carried:	0	5%L1Ring	5%L2Ring
Flying:	Yes	Yes	Yes
AI Type:	Normal	Normal	Aggressive
Attack Speed:	50	50	50
Preferred Enemy:	None	None	None
Special Attack:	Disease1	Disease1	Disease2
PA Type:	Physical	Physical	Physical
PA Damage:	1D3	1D3+2	2D3+2
PA Missile:	0	0	0
Resist:	F (N), E (N), C (N), P (N), Ph (N), M (N)	F (N), E (N), C (N), P (N), Ph (N), M (N)	F (N), E (N), C (N), P (N), Ph (N), M (N)



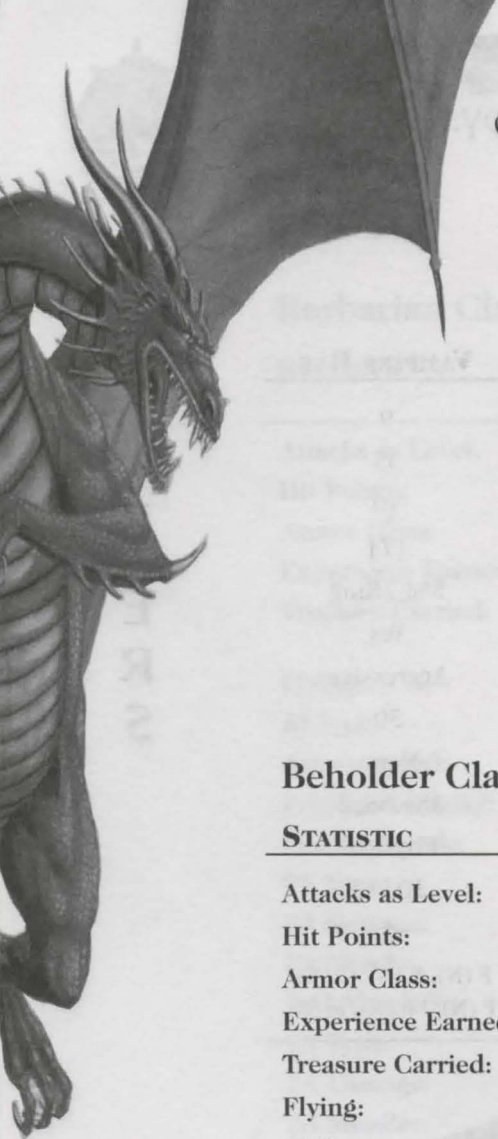

Beholder Class

STATISTIC	FLYING EYE	TERRIBLE EYE	MADDENING EYE
Attacks as Level:	30	40	50
Hit Points:	180	280	400
Armor Class:	25	30	35
Experience Earned:	1200	2000	3000
Treasure Carried:	10%L4Ring	20%L5Ring	30%L6Ring
Flying:	Yes	Yes	Yes
AI Type:	Aggressive	Aggressive	Suicidal
Attack Speed:	100	100	100
Preferred Enemy:	None	Druid, Sorcerer	Druid, Sorcerer
Special Attack:	Asleep	Afraid	Insane
PA Type:	Cold	Fire	Electrical
PA Damage:	5D6	6D6	7D6
PA Missile:	Cold	Fire	Electrical
Spell Use %:	0	20	20
Spell:	N/A	Fireball	Dispel Magic
Resist:	F (SR), E (SR), C (Imm), P (N), Ph (N), M (Imm)	F (Imm), E (SR), C (SR), P (N), Ph (N), M (Imm)	F (SR), E (Imm), C (SR), P (N), Ph (N), M (Imm)

CHAPTER 3 KNOW THINE ENEMY: Monsters



M O N S T E R S

Bloodsucker Class

STATISTIC	BLOOD SUCKER	BRAIN SUCKER	SOUL SUCKER
Attacks as Level:	2	4	8
Hit Points:	6	13	30
Armor Class:	6	8	10
Experience Earned:	24	56	144
Treasure Carried:	0	5%L1Ring	5%L2Ring
Flying:	Yes	Yes	Yes
AI Type:	Normal	Aggressive	Suicidal
Attack Speed:	70	70	70
Preferred Enemy:	None	None	None
Special Attack:	Disease1x2	Disease1x5	Disease2x2
PA Type:	Physical	Physical	Physical
PA Damage:	1D2	1D2+2	2D2+2
PA Missile:	0	0	0
Resist:	F (N), E (N), C (N), P (N), Ph (N), M (N)	F (N), E (N), C (N), P (N), Ph (N), M (N)	F (N), E (N), C (N), P (N), Ph (N), M (N)



MIGHT & MAGIC VI: The Mandate of Heaven



Cleric Class

STATISTIC	ACOLYTE OF BAA	CLERIC OF BAA	PRIEST OF BAA
Attacks as Level:	8	15	25
Hit Points:	30	67	137
Armor Class:	14	18	22
Experience Earned:	144	375	875
Treasure Carried:	10D10+ 5%L1Mace	20D10+ 5%L2Mace	100D10+ 10%L3Misc
Flying:	No	No	No
AI Type:	Wimp	Normal	Aggressive
Attack Speed:	100	100	100
Preferred Enemy:	None	None	Any Two
Special Attack:	0	0	0
PA Type:	Electrical	Electrical	Electrical
PA Damage:	2D4	2D4+4	2D4+8
PA Missile:	Electrical	Electrical	Electrical
Spell Use %:	0	20	20
Spell:	N/A	Harm	Flying Fist
Resist:	F (N), E (N), C (N), P (N), Ph (N), M (N)	F (N), E (N), C (N), P (N), Ph (N), M (N)	F (N), E (N), C (N), P (N), Ph (N), M (N)

CHAPTER 3 KNOW THINE ENEMY: Monsters



M O N S T E R S

Cobra Class

STATISTIC	COBRA	KING COBRA	QUEEN COBRA
Attacks as Level:	5	10	14
Hit Points:	17	40	61
Armor Class:	10	12	16
Experience Earned:	75	200	336
Treasure Carried:	5%L1Misc	5%L2Misc	10%L3Misc
Flying:	No	No	No
AI Type:	Normal	Aggressive	Suicidal
Attack Speed:	70	70	50
Preferred Enemy:	None	None	None
Special Attack:	Poison1x5	Poison1x5	Poison2x2
PA Type:	Physical	Physical	Physical
PA Damage:	1D3+6	2D3+6	3D3+6
PA Missile:	0	0	0
2nd Attack %:	20	20	20
2A Type:	Poison	Poison	Poison
2A Damage:	2D6	3D6	4D6
2A Missile:	0	0	0
Resist:	F (N), E (N), C (N), P (Imm), Ph (N), M (N)	F (N), E (N), C (N), P (Imm), Ph (N), M (N)	F (N), E (N), C (N), P (Imm), Ph (N), M (N)



Cockatrice Class

STATISTIC	AGAR'S PET	AGAR'S MONSTER	AGAR'S ABOMINATION
Attacks as Level:	13	15	17
Hit Points:	55	67	79
Armor Class:	13	15	17
Experience Earned:	299	375	459
Treasure Carried:	4D20	6D20	10D20
Flying:	Yes	Yes	Yes
AI Type:	Normal	Aggressive	Suicidal
Attack Speed:	100	100	100
Preferred Enemy:	Druid	Druid	Druid
Special Attack:	Paralyze	Paralyze	Stone×2
PA Type:	Physical	Physical	Physical
PA Damage:	1D12	1D12+6	2D12+6
PA Missile:	0	0	0
Resist:	F (SR), E (SR), C (SR), P (SR), Ph (N), M (Imm)	F (SR), E (SR), C (SR), P (SR), Ph (N), M (Imm)	F (R), E (R), C (R), P (R), Ph (N), M (Imm)



CHAPTER 3 KNOW THINE ENEMY: Monsters



MONSTERS

Demon Fly Class

STATISTIC	DEVIL CAPTAIN	DEVIL MASTER	DEVIL KING
Attacks as Level:	30	50	70
Hit Points:	180	400	700
Armor Class:	25	35	45
Experience Earned:	1200	3000	5600
Treasure Carried:	0	0	0
Flying:	Yes	Yes	Yes
AI Type:	Aggressive	Aggressive	Suicidal
Attack Speed:	80	80	80
Preferred Enemy:	None	None	None
Special Attack:	Disease2	Disease3	Drain Spell Points
PA Type:	Physical	Physical	Physical
PA Damage:	2D8+10	2D8+15	2D8+20
PA Missile:	0	0	0
2nd Attack %:	20	20	20
2A Type:	Fire	Fire	Fire
2A Damage:	3D8	4D8	5D8
2A Missile:	Fire	Fire	Fire
Spell Use %:	20	20	20
Spell:	Fireball	Meteor Shower	Incinerate
Resist:	F (SR), E (SR), C (SR), P (SR), Ph (N), M (SR)	F (SR), E (SR), C (SR), P (SR), Ph (N), M (SR)	F (R), E (R), C (R), P (R), Ph (N), M (R)

MIGHT & MAGIC VI: The Mandate of Heaven

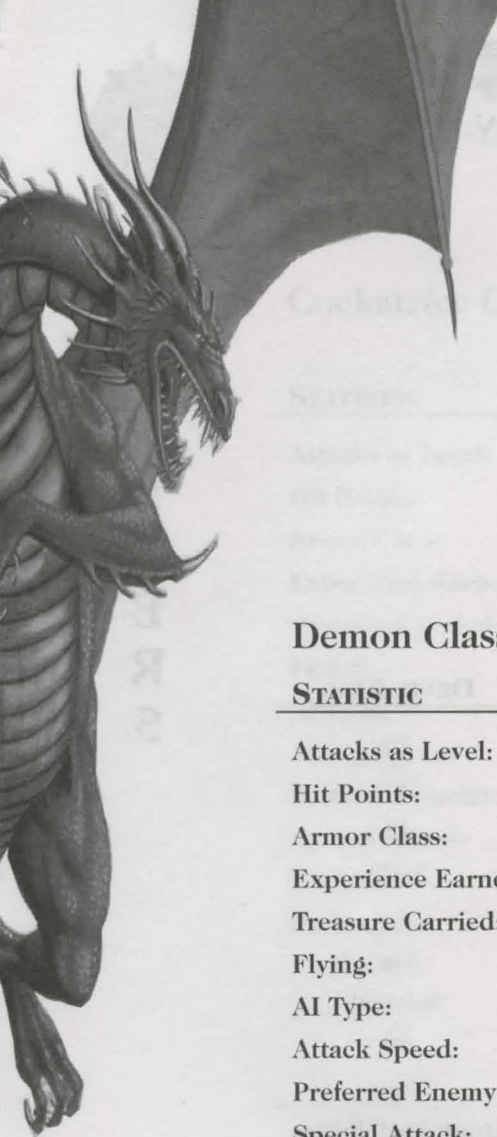

Demon Class

STATISTIC	DEVIL SPAWN	DEVIL WORKER	DEVIL WARRIOR
Attacks as Level:	20	40	60
Hit Points:	100	280	540
Armor Class:	20	30	40
Experience Earned:	600	2000	4200
Treasure Carried:	0	0	0
Flying:	No	No	No
AI Type:	Aggressive	Aggressive	Suicidal
Attack Speed:	90	90	90
Preferred Enemy:	None	None	None
Special Attack:	Disease2	Disease3	Drain Spell Points
PA Type:	Physical	Physical	Physical
PA Damage:	2D6+8	2D6+14	2D6+20
PA Missile:	0	0	0
2nd Attack %:	20	20	20
2A Type:	Fire	Fire	Fire
2A Damage:	3D6	4D6	5D6
2A Missile:	Fire	Fire	Fire
Spell Use %:	20	20	20
Spell:	Fire Bolt	Fire Bolt	Fireball
Resist:	F (SR), E (SR), C (SR), P (SR), Ph (N), M (SR)	F (SR), E (SR), C (SR), P (SR), Ph (N), M (SR)	F (R), E (R), C (R), P (R), Ph (N), M (R)

CHAPTER 3 KNOW THINE ENEMY: Monsters



M O N S T E R S

Dragon Cave Class

STATISTIC	FIRE LIZARD	LIGHTNING LIZARD	THUNDER LIZARD
Attacks as Level:	40	50	60
Hit Points:	280	400	540
Armor Class:	40	50	60
Experience Earned:	2000	3000	4200
Treasure Carried:	100D20+20%L4	150D20+20%L5	200D20+20%L5
Flying:	No	No	No
AI Type:	Aggressive	Aggressive	Aggressive
Attack Speed:	100	100	100
Preferred Enemy:	Any Two	Any Two	Any Two
Special Attack:	0	Break Item	Break Item
PA Type:	Fire	Electrical	Cold
PA Damage:	10D6	12D6	14D6
PA Missile:	Fire	Electrical	Cold
Resist:	F (Imm), E (N), C (N), P (N), Ph (N), M (N)	F (SR), E (Imm), C (SR), P (SR), Ph (N), M (N)	F (SR), E (SR), C (Imm), P (SR), Ph (N), M (N)



Dragon Fly Class

STATISTIC	FLAME DRAKE	FROST DRAKE	ENERGY DRAKE
Attacks as Level:	24	28	32
Hit Points:	129	162	198
Armor Class:	20	25	30
Experience Earned:	816	1064	1344
Treasure Carried:	10%L2	10%L3	20%L4
Flying:	Yes	Yes	Yes
AI Type:	Aggressive	Aggressive	Suicidal
Attack Speed:	100	100	100
Preferred Enemy:	None	None	None
Special Attack:	0	0	Break Item
PA Type:	Fire	Cold	Energy
PA Damage:	10D4	12D4	15D4
PA Missile:	Fire	Cold	Energy
Resist:	F (Imm), E (N), C (N), P (SR), Ph (N), M (N)	F (N), E (SR), C (Imm), P (N), Ph (N), M (N)	F (SR), E (SR), C (SR), P (N), Ph (N), M (N)



CHAPTER 3 KNOW THINE ENEMY: Monsters



M O N S T E R S



Dragon Land Class

STATISTIC	WYRM	GIANT WYRM	GREAT WYRM
Attacks as Level:	50	60	70
Hit Points:	400	540	700
Armor Class:	40	50	60
Experience Earned:	3000	4200	5600
Treasure Carried:	100D10+L5	150D10+L5	200D10+L6
Flying:	No	No	No
AI Type:	Aggressive	Aggressive	Aggressive
Attack Speed:	90	90	90
Preferred Enemy:	Any Two	Any Three	Any Four
Special Attack:	Poison2	Poison3	Poison3
PA Type:	Poison	Poison	Poison
PA Damage:	10D10	10D10	10D10
PA Missile:	Poison	Poison	Poison
Resist:	F (SR), E (SR), C (SR), P (Imm), Ph (N), M (SR)	F (SR), E (SR), C (SR), P (Imm), Ph (N), M (SR)	F (SR), E (SR), C (SR), P (Imm), Ph (N), M (R)

Dragon Cover Class

STATISTIC	RED DRAGON	BLUE DRAGON	GOLD DRAGON
Attacks as Level:	80	90	100
Hit Points:	880	1080	1300
Armor Class:	60	80	100
Experience Earned:	7200	9000	11000
Treasure Carried:	250D10+L6	300D10+L6	400D10+L6
Flying:	Yes	Yes	Yes
AI Type:	Aggressive	Aggressive	Aggressive
Attack Speed:	90	90	90
Preferred Enemy:	Any Four	Any Four	Any Four
Special Attack:	0	Break Item	Break Item
PA Type:	Fire	Cold	Energy
PA Damage:	12D8	14D8	16D8
PA Missile:	Fire	Cold	Energy
Resist:	F (Imm), E (R), C (N), P (R), Ph (SR), M (R)	F (N), E (R), C (Imm), P (R), Ph (SR), M (R)	F (R), E (R), C (R), P (R), Ph (SR), M (Imm)



CHAPTER 3 KNOW THINE ENEMY: Monsters



M O N S T E R S

Druidess Class

STATISTIC	DRUID	GREAT DRUID	GRAND DRUID
Attacks as Level:	10	16	28
Hit Points:	40	73	162
Armor Class:	12	16	22
Experience Earned:	200	416	1064
Treasure Carried:	10D10+ 5%L1Misc	20D10+ 10%L2Misc	50D10+ 20%L3Misc
Flying:	No	No	No
AI Type:	Normal	Aggressive	Aggressive
Attack Speed:	100	100	100
Preferred Enemy:	Knight	Knight	Any Two
Special Attack:	0	0	Drain Spell Points
PA Type:	Fire	Cold	Magic
PA Damage:	2D4+3	2D4+6	2D4+12
PA Missile:	Fire	Cold	Magic
Spell Use %:	40	40	30
Spell:	Harm	Deadly Swarm	Fireball
Resist:	F (SR), E (SR), C (SR), P (SR), Ph (N), M (SR)	F (SR), E (SR), C (SR), P (SR), Ph (N), M (SR)	F (R), E (R), C (R), P (R), Ph (N), M (R)



Dwarf Class

STATISTIC	DWARF	DWARF WARRIOR	DWARF LORD
Attacks as Level:	5	10	20
Hit Points:	17	40	100
Armor Class:	6	12	20
Experience Earned:	200	600	1200
Treasure Carried:	5D10+5%L1	10D10+10%L2Axe	20D10+25%L3Axe
Flying:	No	No	No
AI Type:	Normal	Aggressive	Suicidal
Attack Speed:	100	100	80
Preferred Enemy:	None	None	Sorcerer
Special Attack:	0	0	Break Armor×2
PA Type:	Physical	Physical	Physical
PA Damage:	4D2+2	4D2+2	4D2+10
PA Missile:	0	0	0
2nd Attack %:	0	0	20
2A Type:	0	0	Physical
2A Damage:	0	0	8D2+20
2A Missile:	0	0	0
Resist:	F (SR), E (SR), C (SR), P (Imm), Ph (N), M (SR)	F (SR), E (SR), C (SR), P (Imm), Ph (N), M (R)	F (R), E (R), C (R), P (Imm), Ph (N), M (R)



CHAPTER 3 KNOW THINE ENEMY: Monsters



M O N S T E R S



Element Air Class

STATISTIC	DUST DEVIL	TWISTER	AIR ELEMENTAL
Attacks as Level:	16	22	33
Hit Points:	73	114	207
Armor Class:	10	12	14
Experience Earned:	416	704	1419
Treasure Carried:	0	0	0
Flying:	Yes	Yes	Yes
AI Type:	Suicidal	Suicidal	Suicidal
Attack Speed:	100	100	100
Preferred Enemy:	None	None	Sorcerer
Special Attack:	0	0	Break Item
PA Type:	Electrical	Electrical	Electrical
PA Damage:	3D6	5D6	8D6
PA Missile:	Electrical	Electrical	Electrical
Resist:	F (N), E (Imm), C (N), P (Imm), Ph (SR), M (Imm)	F (N), E (Imm), C (N), P (Imm), Ph (SR), M (Imm)	F(N), E (Imm), C (N), P (Imm), Ph (SR), M (Imm)



Element Earth Class

STATISTIC	ROCK BEAST	EARTH SPIRIT	EARTH ELEMENTAL
Attacks as Level:	25	30	40
Hit Points:	137	180	280
Armor Class:	20	25	30
Experience Earned:	875	1200	2000
Treasure Carried:	10D20	15D20	30D20
Flying:	No	No	No
AI Type:	Suicidal	Suicidal	Suicidal
Attack Speed:	100	100	100
Preferred Enemy:	None	None	Sorcerer
Special Attack:	0	Break Armor	Unconscious
PA Type:	Physical	Physical	Physical
PA Damage:	10D3	15D3	25D3
PA Missile:	0	0	0
2nd Attack %:	20	20	20
2A Type:	Physical	Physical	Physical
2A Damage:	5D3	7D3	12D3
2A Missile:	Rock	Rock	Rock
Resist:	F (N), E (N), C (N), P (Imm), Ph (SR), M (Imm)	F (N), E (N), C (N), P (Imm), Ph (SR), M (Imm)	F (N), E (N), C (N), P (Imm), Ph (SR), M (Imm)

CHAPTER 3 KNOW THINE ENEMY: Monsters



MONSTERS

Element Fire Class

STATISTIC	FIRE BEAST	FIRE SPIRIT	FIRE ELEMENTAL
Attacks as Level:	13	26	39
Hit Points:	55	145	269
Armor Class:	12	15	18
Experience Earned:	299	936	1911
Treasure Carried:	0	0	0
Flying:	Yes	Yes	Yes
AI Type:	Suicidal	Suicidal	Suicidal
Attack Speed:	100	100	100
Preferred Enemy:	None	None	Sorcerer
Special Attack:	0	0	Break Item
PA Type:	Fire	Fire	Fire
PA Damage:	2D8	5D8	8D8
PA Missile:	Fire	Fire	Fire
Resist:	F (Imm), E (N), C (N), P (Imm), Ph (SR), M (Imm)	F (Imm), E (N), C (N), P (Imm), Ph (SR), M (Imm)	F (Imm), E (N), C (N), P (Imm), Ph (SR), M (Imm)



Element Water Class

STATISTIC	WATER BEAST	WATER SPIRIT	WATER ELEMENTAL
Attacks as Level:	14	24	36
Hit Points:	61	129	237
Armor Class:	10	13	16
Experience Earned:	336	816	1656
Treasure Carried:	0	0	0
Flying:	No	No	No
AI Type:	Suicidal	Suicidal	Suicidal
Attack Speed:	90	90	90
Preferred Enemy:	None	None	Sorcerer
Special Attack:	0	0	Break Item
PA Type:	Physical	Physical	Physical
PA Damage:	3D12	4D12	6D12
PA Missile:	0	0	0
Spell Use %:	30	30	30
Spell:	Ice Bolt	Ice Bolt	Ice Bolt
Resist:	F (N), E (N), C (Imm), P (Imm), Ph (SR), M (Imm)	F (N), E (N), C (Imm), P (Imm), Ph (SR), M (Imm)	F (N), E (N), C (Imm), P (Imm), Ph (SR), M (Imm)

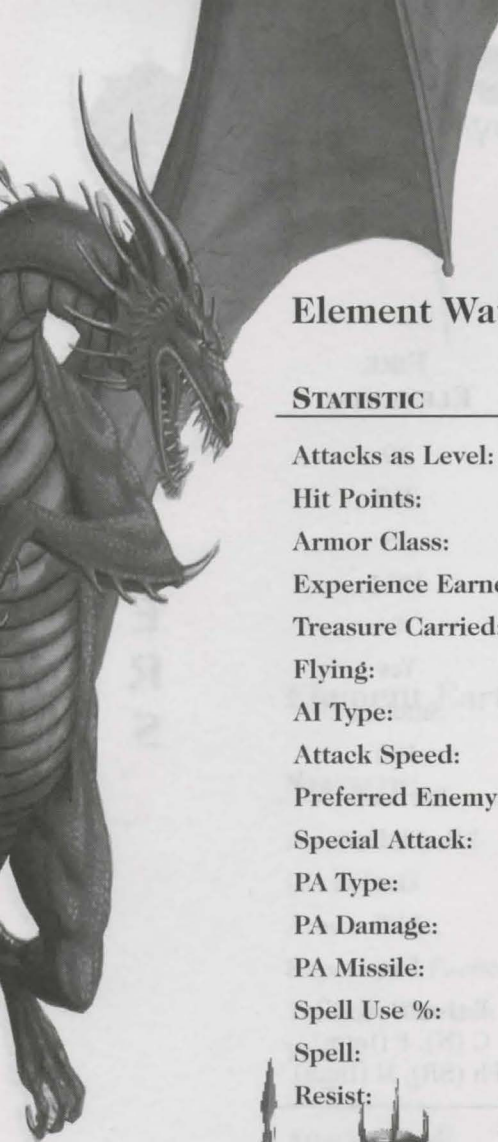

CHAPTER 3 KNOW THINE ENEMY: Monsters



M O N S T E R S

Fighter Chain Class

STATISTIC	FIGHTER	SOLDIER	VETERAN
Attacks as Level:	14	24	35
Hit Points:	61	129	227
Armor Class:	18	24	30
Experience Earned:	336	816	1575
Treasure Carried:	10D10+ 5%L1Chain	20D10+ 5%L2Chain	30D10+ 10%L3Chain
Flying:	No	No	No
AI Type:	Normal	Aggressive	Aggressive
Attack Speed:	100	100	90
Preferred Enemy:	None	Paladin, Cleric	Paladin, Cleric
Special Attack:	0	0	Break Weapon
PA Type:	Physical	Physical	Physical
PA Damage:	3D3+6	3D3+10	3D3+14
PA Missile:	0	0	0
2nd Attack %:	0	0	20
2A Type:	0	0	Physical
2A Damage:	0	0	3D3+45
2A Missile:	0	0	0
Resist:	F (N), E (N), C (N), P (N), Ph (N), M (N)	F (N), E (N), C (N), P (N), Ph (N), M (N)	F (SR), E (SR), C (SR), P (SR), Ph (N), M (SR)



Fighter Leath Class

STATISTIC	THUG	RUFFIAN	BRIGAND
Attacks as Level:	6	12	22
Hit Points:	21	50	114
Armor Class:	12	14	16
Experience Earned:	144	336	704
Treasure Carried:	3D20+ 5%L1Leather	5D20+ 5%L2Leather	10D20+ 10%L3Leather
Flying:	No	No	No
AI Type:	Normal	Aggressive	Aggressive
Attack Speed:	90	90	80
Preferred Enemy:	None	Archer, Sorcerer	Archer, Sorcerer
Special Attack:	0	0	0
PA Type:	Physical	Physical	Physical
PA Damage:	2D4+1	2D4+5	2D4+10
PA Missile:	0	0	0
2nd Attack %:	0	0	10
2A Type:	0	0	Physical
2A Damage:	0	0	2D4+20
2A Missile:	0	0	0
Resist:	F (N), E (N), C (N), P (N), Ph (N), M (N)	F (N), E (N), C (N), P (N), Ph (N), M (N)	F (SR), E (SR), C (SR), P (SR), Ph (N), M (SR)



CHAPTER 3 KNOW THINE ENEMY: Monsters



MONSTERS



Gargoyle Class

STATISTIC	STONE GARGOYLE	MARBLE GARGOYLE	DIAMOND GARGOYLE
Attacks as Level:	13	17	21
Hit Points:	55	79	107
Armor Class:	18	22	26
Experience Earned:	416	704	1419
Treasure Carried:	5D10+ 5%L2Amulet	10D10+ 10%L2Amulet	25D10+ 20%L3Amulet
Flying:	Yes	Yes	Yes
AI Type:	Aggressive	Aggressive	Suicidal
Attack Speed:	80	80	80
Preferred Enemy:	Female, Cleric	Female, Cleric	Female, Cleric
Special Attack:	Weak	Paralyze	Paralyze
PA Type:	Physical	Physical	Physical
PA Damage:	2D12	2D12+4	2D12+8
PA Missile:	0	0	0
Resist:	F (N), E (N), C (N), P (Imm), Ph (SR), M (SR)	F (N), E (N), C (N), P (Imm), Ph (R), M (SR)	F (N), E (N), C (N), P (Imm), Ph (Imm), M (SR)

MIGHT & MAGIC VI: The Mandate of Heaven

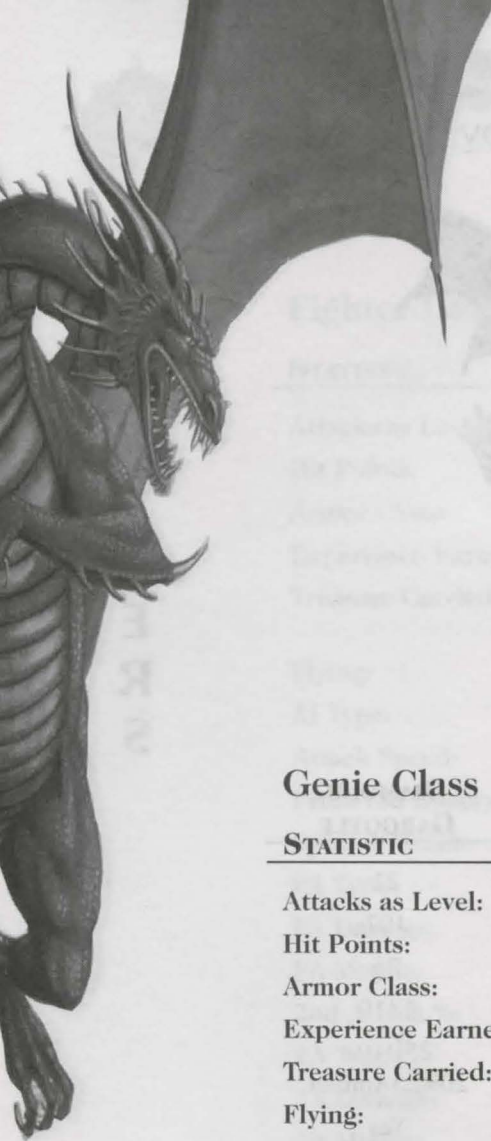

Genie Class

STATISTIC	GENIE	DJINN	EFREET
Attacks as Level:	33	44	55
Hit Points:	207	325	467
Armor Class:	35	45	55
Experience Earned:	1419	2376	3575
Treasure Carried:	30%L4	30%L5	30%L6
Flying:	Yes	Yes	Yes
AI Type:	Aggressive	Aggressive	Aggressive
Attack Speed:	80	80	80
Preferred Enemy:	Male	Male	Male
Special Attack:	0	Asleep	Afraid
PA Type:	Cold	Electrical	Fire
PA Damage:	8D4+8	10D4+10	12D4+12
PA Missile:	Cold	Electrical	Fire
Spell Use %:	20	20	20
Spell:	Ice Bolt	Lightning Bolt	Fireball
Resist:	F (N), E (N), C (Imm), P (N), Ph (N), M (Imm)	F (N), E (Imm), C (N), P (N), Ph (N), M (Imm)	F (Imm), E (N), C (N), P (N), Ph (N), M (Imm)

CHAPTER 3 KNOW THINE ENEMY: Monsters



M O N S T E R S

Ghost Class

STATISTIC	GHOST	EVIL SPIRIT	SPECTER
Attacks as Level:	9	13	19
Hit Points:	35	55	93
Armor Class:	25	30	35
Experience Earned:	171	299	551
Treasure Carried:	5%L2Ring	10%L3Ring	20%L4Ring
Flying:	Yes	Yes	Yes
AI Type:	Wimp	Normal	Suicidal
Attack Speed:	100	100	100
Preferred Enemy:	None	None	None
Special Attack:	Afraid	Age×2	Unconscious
PA Type:	Magic	Magic	Magic
PA Damage:	1D6+3	2D6+3	3D6+3
PA Missile:	0	0	0
Resist:	F (N), E (N), C (N), P (Imm), Ph (SR), M (Imm)	F (N), E (N), C (N), P (Imm), Ph (SR), M (Imm)	F (N), E (N), C (N), P (Imm), Ph (SR), M (Imm)



Goblin Class

STATISTIC	GOBLIN	GOBLIN SHAMAN	GOBLIN KING
Attacks as Level:	4	6	10
Hit Points:	13	21	40
Armor Class:	6	10	14
Experience Earned:	56	96	200
Treasure Carried:	4D4	8D4	15D4+10%L1
Flying:	No	No	No
AI Type:	Wimp	Normal	Aggressive
Attack Speed:	100	100	90
Preferred Enemy:	None	None	Druid
Special Attack:	0	0	Break Item
PA Type:	Physical	Physical	Physical
PA Damage:	1D9	1D9+2	1D9+4
PA Missile:	0	0	0
Spell Use %:	0	10	10
Spell:	N/A	Fire Bolt	Fire Bolt
Resist:	F (N), E (N), C (N), P (N), Ph (N), M (N)	F (N), E (N), C (N), P (N), Ph (N), M (N)	F (SR), E (SR), C (SR), P (SR), Ph (SR), M (SR)



CHAPTER 3 KNOW THINE ENEMY: Monsters



M O N S T E R S

Guard Class

STATISTIC	GUARD	LIEUTENANT	CAPTAIN
Attacks as Level:	11	19	33
Hit Points:	45	93	207
Armor Class:	16	24	32
Experience Earned:	231	551	1419
Treasure Carried:	3D20+ 5%L1Armor	5D20+ 5%L2Armor	10D20+ 10%L3Armor
Flying:	No	No	No
AI Type:	Normal	Normal	Aggressive
Attack Speed:	90	90	80
Preferred Enemy:	None	None	None
Special Attack:	0	0	Break Armor
PA Type:	Physical	Physical	Physical
PA Damage:	3D3+5	3D3+10	3D3+20
PA Missile:	0	0	0
2nd Attack %:	0	10	10
2A Type:	0	Physical	Physical
2A Damage:	0	3D3+20	3D3+40
2A Missile:	0	0	0
Resist:	F (N), E (N), C (N), P (N), Ph (N), M (N)	F (N), E (N), C (N), P (N), Ph (N), M (N)	F (N), E (N), C (N), P (N), Ph (N), M (N)



MIGHT & MAGIC VI: The Mandate of Heaven



Harpy Class

STATISTIC	HARPY	HARPY HAG	HARPY WITCH
Attacks as Level:	9	12	14
Hit Points:	35	50	61
Armor Class:	12	14	16
Experience Earned:	336	459	551
Treasure Carried:	4D10	6D10	10D10+20%L2Ring
Flying:	Yes	Yes	Yes
AI Type:	Aggressive	Aggressive	Suicidal
Attack Speed:	90	90	80
Preferred Enemy:	Male	Male	Male
Special Attack:	Drunk	Curse×3	Age×3
PA Type:	Physical	Physical	Physical
PA Damage:	2D7+2	2D7+5	2D7+10
PA Missile:	0	0	0
Spell Use %:	0	0	10
Spell:	N/A	N/A	Mass Curse
Resist:	F (N), E (N), C (N), P (N), Ph (N), M (SR)	F (N), E (N), C (N), P (N), Ph (N), M (SR)	F (N), E (N), C (N), P (N), Ph (N), M (R)

CHAPTER 3 KNOW THINE ENEMY: Monsters



M O N S T E R S

Hydra Class

STATISTIC	HYDRA	VENOMOUS HYDRA	COLOSSAL HYDRA
Attacks as Level:	45	55	65
Hit Points:	337	467	617
Armor Class:	22	44	66
Experience Earned:	2475	3575	4875
Treasure Carried:	50D10+L3	100D10+L4	200D10+L5
Flying:	No	No	No
AI Type:	Aggressive	Aggressive	Aggressive
Attack Speed:	100	100	120
Preferred Enemy:	Any Two	Any Two	Any Three
Special Attack:	0	Poison3	Break Item
PA Type:	Physical	Physical	Physical
PA Damage:	15D5	20D5	20D5
PA Missile:	0	0	0
2nd Attack %:	30	30	40
2A Type:	Fire	Poison	Energy
2A Damage:	8D5	10D5	10D5
2A Missile:	Fire	Poison	Energy
Resist:	F (N), E (N), C (N), P (N), Ph (N), M (N)	F (SR), E (SR), C (SR), P (Imm), Ph (SR), M (SR)	F (SR), E (SR), C (SR), P (SR), Ph (SR), M (SR)

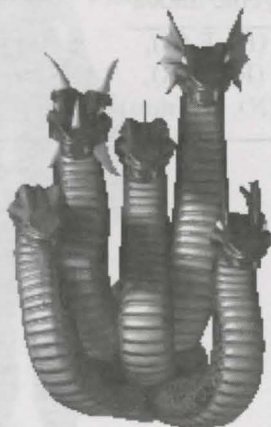

Jackalman Class

STATISTIC	DEFENDER OF VARN	SENTINEL OF VARN	GUARDIAN OF VARN
Attacks as Level:	35	55	65
Hit Points:	227	467	617
Armor Class:	40	50	60
Experience Earned:	1575	3575	4875
Treasure Carried:	100D10	150D10	200D10
Flying:	No	No	No
AI Type:	Normal	Aggressive	Aggressive
Attack Speed:	80	80	80
Preferred Enemy:	None	None	None
Special Attack:	0	0	Break Weapon
PA Type:	Physical	Physical	Physical
PA Damage:	3D6+20	3D6+35	3D6+50
PA Missile:	0	0	0
2nd Attack %:	20	20	20
2A Type:	Energy	Energy	Energy
2A Damage:	5D6	6D6	8D6
2A Missile:	Energy	Energy	Energy
Spell Use %:	20	20	20
Spell:	Psychic Shock	Psychic Shock	Psychic Shock
Resist:	F (SR), E (SR), C (SR), P (SR), Ph (N), M (Imm)	F (R), E (R), C (R), P (R), Ph (N), M (Imm)	F (Imm), E (Imm), C (Imm), P (Imm), Ph (N), M (Imm)

CHAPTER 3 KNOW THINE ENEMY: Monsters



M O N S T E R S

Knight Plate Class

STATISTIC	DEATH KNIGHT	DOOM KNIGHT	CUISINART
Attacks as Level:	23	46	69
Hit Points:	121	349	683
Armor Class:	25	35	45
Experience Earned:	2000	4200	7200
Treasure Carried:	10D100+ 10%L4Plate	20D100+ 10%L5Plate	40D100+ 30%L6Plate
Flying:	No	No	No
AI Type:	Normal	Aggressive	Aggressive
Attack Speed:	80	80	70
Preferred Enemy:	None	Any Two	Any Three
Special Attack:	Afraid	Afraid	Afraid
PA Type:	Physical	Physical	Physical
PA Damage:	4D5+20	4D5+30	4D5+40
PA Missile:	0	0	0
2nd Attack %:	20	20	20
2A Type:	Magic	Magic	Magic
2A Damage:	4D6	6D6	8D6
2A Missile:	Magic	Magic	Magic
Resist:	F (SR), E (SR), C (SR), P (SR), Ph (SR), M (SR)	F (SR), E (SR), C (SR), P (SR), Ph (SR), M (SR)	F (SR), E (SR), C (SR), P (SR), Ph (SR), M (SR)



Lich Class

STATISTIC	LICH	GREATER LICH	POWER LICH
Attacks as Level:	20	30	40
Hit Points:	100	180	280
Armor Class:	15	20	25
Experience Earned:	600	1200	2000
Treasure Carried:	10D20+ 10%L3Misc	15D20+ 10%L4Misc	30D20+ 30%L5Misc
Flying:	No	No	No
AI Type:	Aggressive	Aggressive	Suicidal
Attack Speed:	100	100	90
Preferred Enemy:	None	Archer, Sorcerer	Any Two
Special Attack:	0	0	0
PA Type:	Electrical	Fire	Energy
PA Damage:	3D8+6	4D8+12	5D8+20
PA Missile:	Electrical	Fire	Energy
Spell Use %:	10	10	0
Spell:	Dispel Magic	Dispel Magic	N/A
Resist:	F (SR), E (SR), C (SR), P (SR), Ph (N), M (Imm)	F (SR), E (SR), C (SR), P (SR), Ph (SR), M (Imm)	F (SR), E (SR), C (SR), P (SR), Ph (SR), M (Imm)



CHAPTER 3 KNOW THINE ENEMY: Monsters



M O N S T E R S

Lizard Archer Class

STATISTIC	LIZARD MAN	LIZARD ARCHER	LIZARD WIZARD
Attacks as Level:	4	7	11
Hit Points:	13	25	45
Armor Class:	10	15	20
Experience Earned:	56	119	231
Treasure Carried:	4D8+ 5%L1Bow	6D8+ 5%L1Bow	10D8+ 5%L2Bow
Flying:	No	No	No
AI Type:	Wimp	Normal	Aggressive
Attack Speed:	100	100	100
Preferred Enemy:	None	None	Archer
Special Attack:	0	0	0
PA Type:	Physical	Physical	Physical
PA Damage:	1D6	1D6+2	1D6+5
PA Missile:	Arrow	Arrow	Arrow
2nd Attack %:	0	20	0
2A Type:	0	Fire	0
2A Damage:	0	2D6	0
2A Missile:	0	Fire Arrow	0
Spell Use %:	0	0	50
Spell:	N/A	N/A	Lightning Bolt
Resist:	F (N), E (N), C (N), P (N), Ph (N), M (N)	F (N), E (N), C (N), P (N), Ph (N), M (N)	F (SR), E (SR), C (SR), P (SR), Ph (N), M (N)

Medusa Class

STATISTIC	MEDUSA		
	MEDUSA	ENCHANTRESS	GORGON
Attacks as Level:	35	40	45
Hit Points:	227	280	337
Armor Class:	20	25	30
Experience Earned:	1575	2000	2475
Treasure Carried:	10D20+ 10%L3Misc	15D20+ 10%L4Misc	30D20+ 30%L5Misc
Flying:	No	No	No
AI Type:	Normal	Aggressive	Suicidal
Attack Speed:	100	100	100
Preferred Enemy:	Knight	Knight	Knight
Special Attack:	Stone	Stone	Stone
PA Type:	Magic	Magic	Magic
PA Damage:	4D4+8	5D4+10	6D4+12
PA Missile:	0	0	0
Spell Use %:	30	30	30
Spell:	Harm	Paralyze	Psychic Shock
Resist:	F (N), E (N), C (N), P (N), Ph (N), M (Imm)	F (N), E (N), C (N), P (N), Ph (N), M (Imm)	F (N), E (N), C (N), P (N), Ph (N), M (Imm)



CHAPTER 3 KNOW THINE ENEMY: Monsters



M O N S T E R S

Merchant Class

STATISTIC	PEASANT	PEASANT	PEASANT
Attacks as Level:	4	5	6
Hit Points:	13	17	21
Armor Class:	4	6	8
Experience Earned:	56	75	96
Treasure Carried:	5D20	7D20	10D20
Flying:	No	No	No
AI Type:	Wimp	Normal	Normal
Attack Speed:	100	100	100
Preferred Enemy:	None	None	None
Special Attack:	0	0	0
PA Type:	Physical	Physical	Physical
PA Damage:	2D2	2D2+2	2D2+4
PA Missile:	0	0	0
Resist:	F (N), E (N), C (N), P (N), Ph (N), M (N)	F (N), E (N), C (N), P (N), Ph (N), M (N)	F (N), E (N), C (N), P (N), Ph (N), M (N)



Minotaur Class

STATISTIC	MINOTAUR	MINOTAUR MAGE	MINOTAUR KING
Attacks as Level:	39	59	79
Hit Points:	269	525	861
Armor Class:	30	35	40
Experience Earned:	1911	4071	7031
Treasure Carried:	10D20+ 10%L4Axe	20D20+ 10%L5Axe	50D20+ 20%L6Axe
Flying:	No	No	No
AI Type:	Normal	Aggressive	Suicidal
Attack Speed:	80	80	70
Preferred Enemy:	None	None	Any Two
Special Attack:	0	0	0
PA Type:	Physical	Physical	Physical
PA Damage:	3D7+25	3D7+40	3D7+60
PA Missile:	0	0	0
Spell Use %:	0	20	20
Spell:	N/A	Lightning Bolt	Finger of Death
Resist:	F (SR), E (SR), C (SR), P (SR), Ph (SR), M (Imm)	F (SR), E (SR), C (SR), P (SR), Ph (SR), M (Imm)	F (R), E (R), C (R), P (R), Ph (R), M (Imm)



CHAPTER 3 KNOW THINE ENEMY: Monsters



M O N S T E R S

Monk Class

STATISTIC	NOVICE MONK	INITIATE MONK	MASTER MONK
Attacks as Level:	8	16	27
Hit Points:	30	73	153
Armor Class:	16	19	28
Experience Earned:	144	416	999
Treasure Carried:	5%L1Amulet	5%L2Amulet	10%L3Amulet
Flying:	No	No	No
AI Type:	Normal	Aggressive	Suicidal
Attack Speed:	100	100	100
Preferred Enemy:	None	None	None
Special Attack:	0	0	Weak
PA Type:	Fire	Electrical	Cold
PA Damage:	2D4+2	2D4+8	2D4+16
PA Missile:	Fire	Electrical	Cold
Spell Use %:	20	20	20
Spell:	Fire Bolt	Lightning Bolt	Ice Bolt
Resist:	F (N), E (N), C (N), P (N), Ph (N), M (N)	F (N), E (N), C (N), P (N), Ph (N), M (N)	F (N), E (N), C (N), P (N), Ph (N), M (Imm)



MIȚȚ & MAGIC VI: The Mandate of Heaven



Nobleman Class

STATISTIC	SWORDSMAN	EXPERT SWORDSMAN	MASTER SWORDSMAN
Attacks as Level:	10	17	24
Hit Points:	40	79	129
Armor Class:	10	15	20
Experience Earned:	200	459	816
Treasure Carried:	10D10+ 5%L1Sword	15D10+ 5%L2Sword	30D10+ 10%L3Sword
Flying:	No	No	No
AI Type:	Aggressive	Aggressive	Aggressive
Attack Speed:	90	90	80
Preferred Enemy:	None	None	Any Two
Special Attack:	0	0	Break Weapon
PA Type:	Physical	Physical	Physical
PA Damage:	3D7+4	3D7+6	3D7+8
PA Missile:	0	0	0
2nd Attack %:	0	0	20
2A Type:	0	0	Physical
2A Damage:	0	0	3D7+20
2A Missile:	0	0	0
Resist:	F (N), E (N), C (N), P (N), Ph (N), M (N)	F (N), E (N), C (N), P (N), Ph (N), M (N)	F (SR), E (SR), C (SR), P (SR), Ph (N), M (SR)

CHAPTER 3 KNOW THINE ENEMY: Monsters



M O N S T E R S

Ooze Class

STATISTIC	Ooze	ACIDIC OOZE	CORROSIVE OOZE
Attacks as Level:	12	18	25
Hit Points:	50	86	137
Armor Class:	8	10	12
Experience Earned:	264	504	875
Treasure Carried:	5%L2	5%L3	5%L4
Flying:	No	No	No
AI Type:	Normal	Suicidal	Suicidal
Attack Speed:	120	120	120
Preferred Enemy:	Any Two	Any Three	Any Four
Special Attack:	Poison1x2	Break Itemx2	Break Itemx2
PA Type:	Poison	Poison	Poison
PA Damage:	1D6	3D6	5D6
PA Missile:	0	0	0
Spell Use %:	0	20	20
Spell:	N/A	Poison Spray	Toxic Cloud
Resist:	F (N), E (N), C (N), P (Imm), Ph (N), M (Imm)	F (N), E (N), C (N), P (Imm), Ph (N), M (Imm)	F (N), E (N), C (N), P (Imm), Ph (N), M (Imm)



Ogre Class

STATISTIC	OGRE	OGRE RAIDER	OGRE CHIEFTAIN
Attacks as Level:	15	20	28
Hit Points:	67	100	162
Armor Class:	12	14	16
Experience Earned:	375	600	1064
Treasure Carried:	10D10+ 5%L1Weapon	20D10+ 5%L2Weapon	30D10+ 5%L3Weapon
Flying:	No	No	No
AI Type:	Aggressive	Aggressive	Aggressive
Attack Speed:	100	100	90
Preferred Enemy:	None	None	Any Two
Special Attack:	0	0	Poison2
PA Type:	Physical	Physical	Physical
PA Damage:	2D5+10	2D5+15	2D5+25
PA Missile:	0	0	0
Resist:	F (N), E (N), C (N), P (N), Ph (N), M (N)	F (N), E (N), C (N), P (N), Ph (N), M (N)	F (SR), E (SR), C (SR), P (SR), Ph (N), M (SR)



CHAPTER 3 KNOW THINE ENEMY: Monsters



M O N S T E R S

Peasant Class

STATISTIC	PEASANT	PEASANT	PEASANT
Attacks as Level:	1	2	3
Hit Points:	3	6	9
Armor Class:	3	5	6
Experience Earned:	11	24	39
Treasure Carried:	2D6	3D6	4D6
Flying:	No	No	No
AI Type:	Wimp	Wimp	Wimp
Attack Speed:	100	100	100
Preferred Enemy:	None	None	None
Special Attack:	0	0	0
PA Type:	Physical	Physical	Physical
PA Damage:	2D2	2D2	2D2
PA Missile:	0	0	0
Resist:	F (N), E (N), C (N), P (N), Ph (N), M (N)	F (N), E (N), C (N), P (N), Ph (N), M (N)	F (N), E (N), C (N), P (N), Ph (N), M (N)

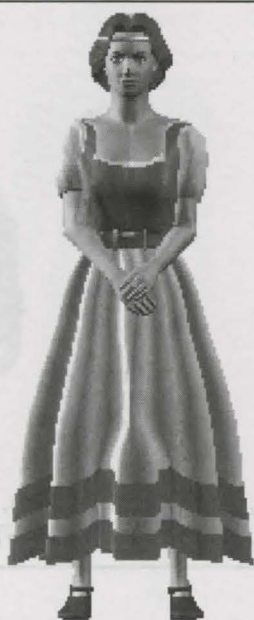

MIGHT & MAGIC VI: The Mandate of Heaven

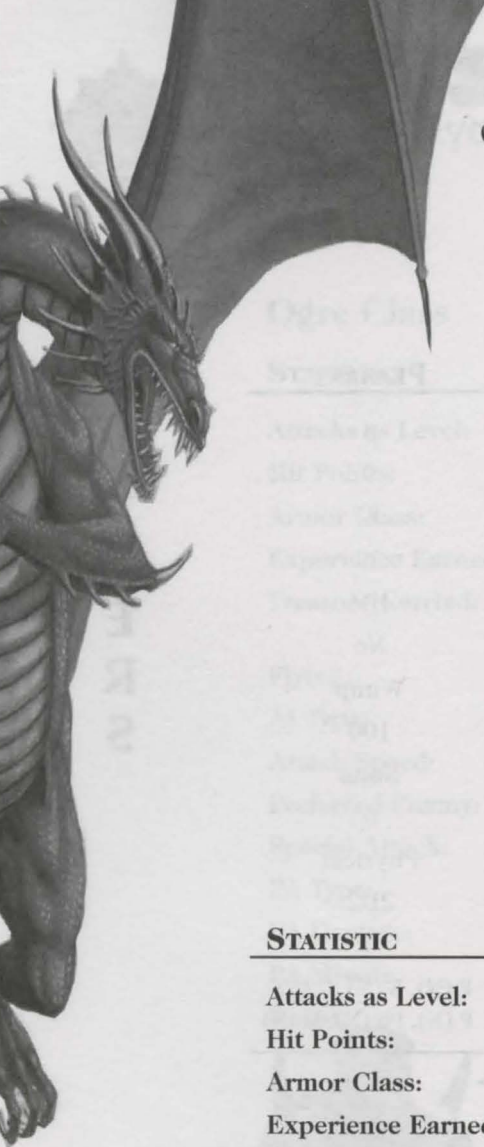

STATISTIC	PEASANT	PEASANT	PEASANT
Attacks as Level:	1	2	3
Hit Points:	3	6	9
Armor Class:	3	5	6
Experience Earned:	11	24	39
Treasure Carried:	2D6	3D6	4D6
Flying:	No	No	No
AI Type:	Wimp	Wimp	Wimp
Attack Speed:	100	100	100
Preferred Enemy:	None	None	None
Special Attack:	0	0	0
PA Type:	Physical	Physical	Physical
PA Damage:	2D2	2D2	2D2
PA Missile:	0	0	0
Resist:	F (N), E (N), C (N), P (N), Ph (N), M (N)	F (N), E (N), C (N), P (N), Ph (N), M (N)	F (N), E (N), C (N), P (N), Ph (N), M (N)

CHAPTER 3 KNOW THINE ENEMY: Monsters



M O N S T E R S

STATISTIC	CUTPURSE	BOUNTY HUNTER	ASSASSIN
Attacks as Level:	3	5	7
Hit Points:	9	17	25
Armor Class:	3	5	10
Experience Earned:	39	75	119
Treasure Carried:	3D6+ 10%L1Dagger	5D6+ 20%L1Dagger	10D6+ 50%L1Dagger
Flying:	No	No	No
AI Type:	Normal	Aggressive	Aggressive
Attack Speed:	100	100	90
Preferred Enemy:	None	None	None
Special Attack:	Steal×2	Steal×2	Dead
PA Type:	Physical	Physical	Physical
PA Damage:	2D2+3	2D2+5	2D2+10
PA Missile:	0	0	0
Resist:	F (N), E (N), C (N), P (N), Ph (N), M (N)	F (N), E (N), C (N), P (N), Ph (N), M (N)	F (N), E (N), C (N), P (N), Ph (N), M (N)



MIGHT & MAGIC VI: The Mandate of Heaven

STATISTIC	CANNIBAL	HEAD HUNTER	WITCH DOCTOR
Attacks as Level:	6	8	10
Hit Points:	21	30	40
Armor Class:	5	7	9
Experience Earned:	96	144	200
Treasure Carried:	2D6+ 5%L1Shield	4D6+ 10%L1Shield	6D6+ 5%L1Amulet
Flying:	No	No	No
AI Type:	Suicidal	Suicidal	Suicidal
Attack Speed:	90	90	90
Preferred Enemy:	None	None	None
Special Attack:	0	Weak	0
PA Type:	Physical	Physical	Physical
PA Damage:	3D3+2	3D3+4	3D3+6
PA Missile:	0	0	0
Spell Use %:	0	0	20
Spell:	N/A	N/A	Deadly Swarm
Resist:	F (N), E (N), C (N), P (N), Ph (N), M (N)	F (N), E (N), C (N), P (N), Ph (N), M (N)	F (N), E (N), C (N), P (N), Ph (N), M (N)



CHAPTER 3 KNOW THINE ENEMY: Monsters



MONSTERS

STATISTIC	PEASANT	PEASANT	PEASANT
Attacks as Level:	1	2	3
Hit Points:	3	6	9
Armor Class:	3	5	6
Experience Earned:	11	24	39
Treasure Carried:	3D3	4D4	8D8
Flying:	No	No	No
AI Type:	Wimp	Wimp	Wimp
Attack Speed:	100	100	100
Preferred Enemy:	None	None	None
Special Attack:	0	0	0
PA Type:	Physical	Physical	Physical
PA Damage:	2D2	2D2	2D2
PA Missile:	0	0	0
Resist:	F (N), E (N), C (N), P (N), Ph (N), M (N)	F (N), E (N), C (N), P (N), Ph (N), M (N)	F (N), E (N), C (N), P (N), Ph (N), M (N)



MIGHT & MAGIC VI: The Mandate of Heaven

STATISTIC	APPRENTICE	JOURNEYMAN	
	MAGE	MAGE	MAGE
Attacks as Level:	2	6	10
Hit Points:	6	21	40
Armor Class:	3	5	7
Experience Earned:	24	96	200
Treasure Carried:	2D6+ 5%L1Staff	5D6+ 5%L1Staff	10D6+ 10%L1Misc
Flying:	No	No	No
AI Type:	Wimp	Normal	Aggressive
Attack Speed:	100	100	100
Preferred Enemy:	None	None	None
Special Attack:	0	0	0
PA Type:	Physical	Physical	Physical
PA Damage:	2D4	2D4+2	2D4+6
PA Missile:	0	0	0
Spell Use %:	20	30	50
Spell:	Flame Arrow	Cold Beam	Lightning Bolt
Resist:	F (N), E (N), C (N), P (N), Ph (N), M (N)	F (N), E (N), C (N), P (N), Ph (N), M (N)	F (N), E (N), C (N), P (N), Ph (N), M (N)



CHAPTER 3 KNOW THINE ENEMY: Monsters



M O N S T E R S

STATISTIC	FOLLOWER OF BAA	MYSTIC OF BAA	FANATIC OF BAA
Attacks as Level:	3	5	7
Hit Points:	9	17	25
Armor Class:	3	5	6
Experience Earned:	39	75	119
Treasure Carried:	2D6	3D6+5%L1Staff	4D6+5%L2Staff
Flying:	No	No	No
AI Type:	Normal	Aggressive	Suicidal
Attack Speed:	100	100	70
Preferred Enemy:	None	None	None
Special Attack:	0	0	0
PA Type:	Physical	Physical	Physical
PA Damage:	2D4	2D4+2	2D4+4
PA Missile:	0	0	0
Spell Use %:	0	20	0
Spell:	N/A	Mind Blast	N/A
Resist:	F (N), E (N), C (N), P (N), Ph (N), M (N)	F (N), E (N), C (N), P (N), Ph (N), M (N)	F (N), E (N), C (N), P (N), Ph (N), M (N)



MIGHT & MAGIC VI: The Mandate of Heaven

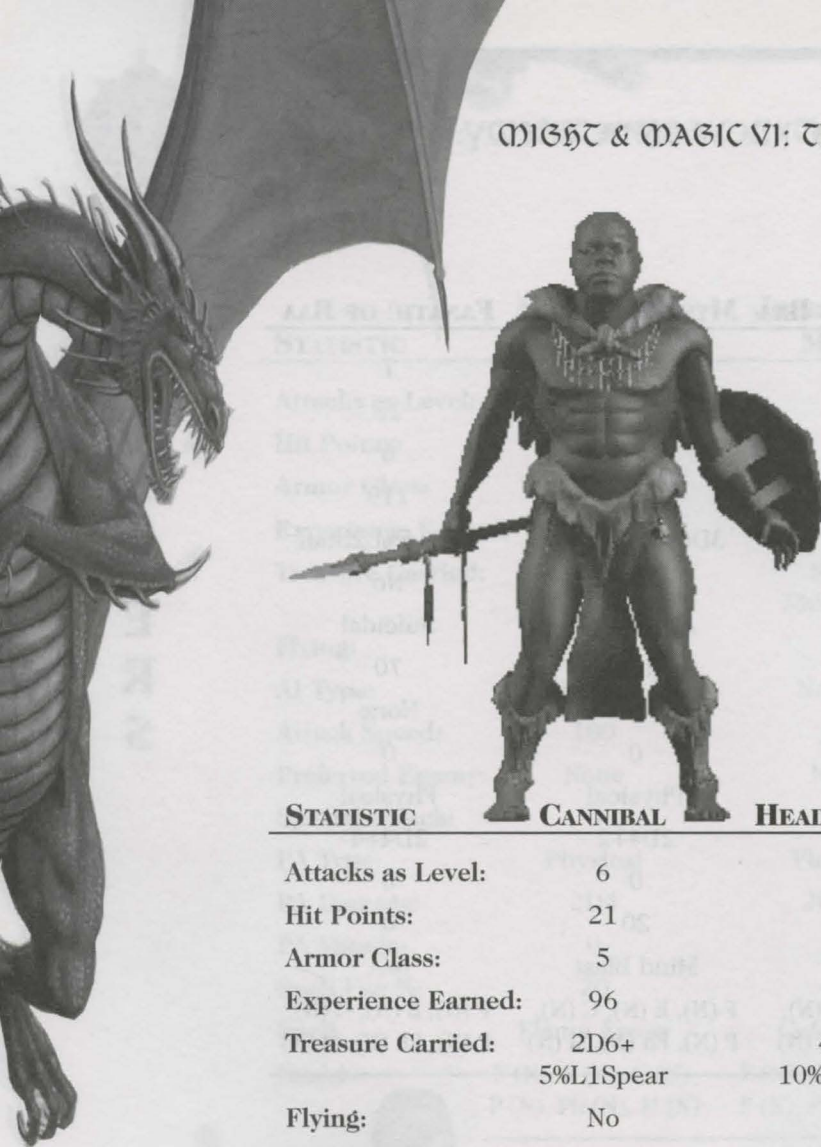

STATISTIC	CANNIBAL	HEAD HUNTER	WITCH DOCTOR
Attacks as Level:	6	8	10
Hit Points:	21	30	40
Armor Class:	5	7	9
Experience Earned:	96	144	200
Treasure Carried:	2D6+ 5%L1Spear	4D6+ 10%L1Spear	6D6+ 5%L2Ring
Flying:	No	No	No
AI Type:	Suicidal	Suicidal	Suicidal
Attack Speed:	90	90	90
Preferred Enemy:	None	None	None
Special Attack:	0	Poison1	0
PA Type:	Physical	Physical	Physical
PA Damage:	1D9+2	1D9+4	1D9+6
PA Missile:	0	0	0
Spell Use %:	0	0	20
Spell:	N/A	N/A	Fire Bolt
Resist:	F (N), E (N), C (N), P (N), Ph (N), M (N)	F (N), E (N), C (N), P (N), Ph (N), M (N)	F (N), E (N), C (N), P (N), Ph (N), M (N)

CHAPTER 3 KNOW THINE ENEMY: Monsters



MONSTERS

Rat Class

STATISTIC	COMMON RAT	LARGE RAT	GIANT RAT
Attacks as Level:	2	4	6
Hit Points:	6	13	21
Armor Class:	4	5	8
Experience Earned:	24	56	96
Treasure Carried:	2%L1Ring	2%L1Ring	2%L1Ring
Flying:	No	No	No
AI Type:	Wimp	Normal	Aggressive
Attack Speed:	100	100	100
Preferred Enemy:	None	None	None
Special Attack:	Disease1x2	Disease1x2	Disease2x2
PA Type:	Physical	Physical	Physical
PA Damage:	1D8	1D8+2	1D8+6
PA Missile:	0	0	0
Resist:	F (N), E (N), C (N), P (N), Ph (N), M (N)	F (N), E (N), C (N), P (N), Ph (N), M (N)	F (N), E (N), C (N), P (N), Ph (N), M (N)

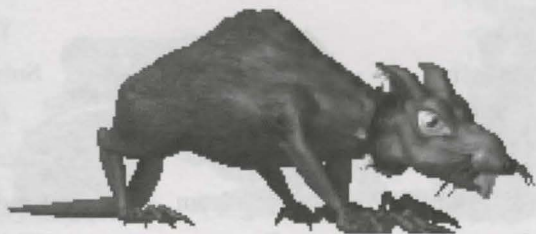

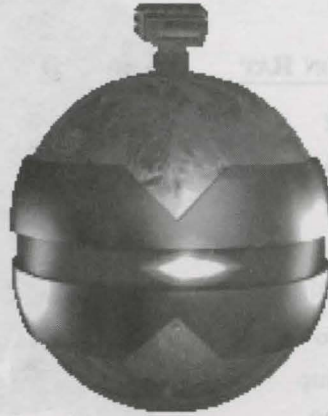

Robot Class

STATISTIC	PATROL UNIT	ENFORCER UNIT	TERMINATOR UNIT
Attacks as Level:	50	75	90
Hit Points:	400	787	1080
Armor Class:	60	80	100
Experience Earned:	3000	5600	9000
Treasure Carried:	0	0	0
Flying:	Yes	Yes	Yes
AI Type:	Aggressive	Suicidal	Suicidal
Attack Speed:	60	60	60
Preferred Enemy:	None	None	None
Special Attack:	Break Item	Break Item	Eradicate
PA Type:	Energy	Energy	Energy
PA Damage:	10D5+10	12D5+15	20D5+20
PA Missile:	Energy	Energy	Energy
Resist:	F (SR), E (SR), C (SR), P (SR), Ph (SR), M (Imm)	F (SR), E (SR), C (SR), P (SR), Ph (SR), M (Imm)	F (R), E (R), C (R), P (R), Ph (R), M (Imm)

CHAPTER 3 KNOW THINE ENEMY: Monsters



M O N S T E R S

Sea Serpent Class

TATISTIC	SEA SERPENT	SEA MONSTER	SEA TERROR
Attacks as Level:	28	36	48
Hit Points:	162	237	374
Armor Class:	30	35	40
Experience Earned:	1064	1656	2784
Treasure Carried:	0	0	0
Flying:	No	No	No
AI Type:	Aggressive	Aggressive	Aggressive
Attack Speed:	100	100	100
Preferred Enemy:	None	None	Any Two
Special Attack:	0	0	Afraid
PA Type:	Cold	Cold	Cold
PA Damage:	1D20+25	1D20+35	1D20+45
PA Missile:	Cold	Cold	Cold
Resist:	F (N), E (N), C (N), P (N), Ph (N), M (N)	F (N), E (N), C (N), P (N), Ph (N), M (N)	F (N), E (N), C (N), P (N), Ph (N), M (N)

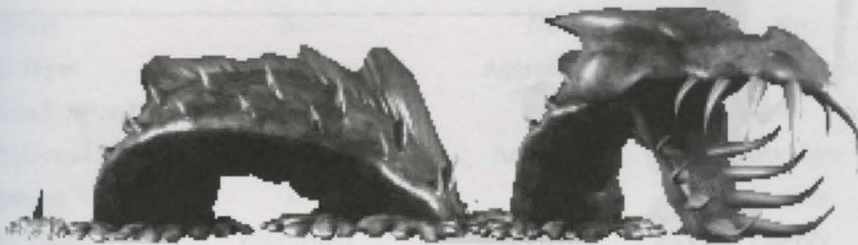

Skeleton Class

STATISTIC	SKELETON	SKELETON KNIGHT	SKELETON LORD
Attacks as Level:	4	8	14
Hit Points:	13	30	61
Armor Class:	8	10	14
Experience Earned:	96	200	336
Treasure Carried:	4D6	7D6	10D6+5%L2Sword
Flying:	No	No	No
AI Type:	Aggressive	Aggressive	Suicidal
Attack Speed:	100	100	100
Preferred Enemy:	None	None	None
Special Attack:	0	Afraid	Curse×2
PA Type:	Physical	Physical	Physical
PA Damage:	3D4	3D4+2	3D4+6
PA Missile:	0	0	0
Resist:	F (N), E (N), C (N), P (N), Ph (N), M (Imm)	F (N), E (N), C (N), P (N), Ph (N), M (Imm)	F (N), E (N), C (N), P (N), Ph (N), M (Imm)





CHAPTER 3 KNOW THINE ENEMY: Monsters



MONSTERS

Sorcerer Class

STATISTIC	SORCERER	MAGICIAN	WARLOCK
Attacks as Level:	18	27	45
Hit Points:	86	153	337
Armor Class:	14	18	30
Experience Earned:	875	1575	3000
Treasure Carried:	10D10+ 10%L2Staff	20D10+ 10%L3Staff	40D10+ 20%L5Staff
Flying:	No	No	No
AI Type:	Aggressive	Aggressive	Aggressive
Attack Speed:	100	100	90
Preferred Enemy:	Knight, Archer	Any Two	Any Two
Special Attack:	0	0	Insane
PA Type:	Electrical	Electrical	Energy
PA Damage:	6D4	8D4	16D4
PA Missile:	Electrical	Electrical	Energy
Spell Use %:	20	20	20
Spell:	Lightning Bolt	Lightning Bolt	Lightning Bolt
Resist:	F (SR), E (Imm), C (SR), P (SR), Ph (N), M (SR)	F (SR), E (Imm), C (SR), P (SR), Ph (N), M (SR)	F (R), E (Imm), C (R), P (R), Ph (N), M (R)

Spider Class

STATISTIC	SPIDER	GIANT SPIDER	HUGE SPIDER
Attacks as Level:	5	8	12
Hit Points:	17	30	50
Armor Class:	10	12	16
Experience Earned:	75	144	264
Treasure Carried:	0	0	0
Flying:	No	No	No
AI Type:	Normal	Aggressive	Aggressive
Attack Speed:	100	100	100
Preferred Enemy:	None	None	None
Special Attack:	Poison1x5	Poison2x3	Poison3x2
PA Type:	Physical	Physical	Physical
PA Damage:	3D2	3D2+3	3D2+6
PA Missile:	0	0	0
2nd Attack %:	0	10	20
2A Type:	0	Poison	Poison
2A Damage:	0	3D2	4D2
2A Missile:	0	Poison	Poison
Resist:	F (N), E (N), C (N), P (Imm), Ph (N), M (N)	F (N), E (N), C (N), P (Imm), Ph (N), M (N)	F (N), E (N), C (N), P (Imm), Ph (N), M (N)



CHAPTER 3 KNOW THINE ENEMY: Monsters



M O N S T E R S

Thief Class

STATISTIC	THIEF	BURGLAR	ROGUE
Attacks as Level:	5	10	18
Hit Points:	17	40	86
Armor Class:	10	14	20
Experience Earned:	144	264	504
Treasure Carried:	3D10+ 5%L1	4D10+ 10%L1	5D10+ 20%L2Cape
Flying:	No	No	No
AI Type:	Wimp	Normal	Aggressive
Attack Speed:	90	90	90
Preferred Enemy:	None	None	None
Special Attack:	Steal×2	Steal×2	Steal×2
PA Type:	Physical	Physical	Physical
PA Damage:	3D4+3	3D4+6	3D4+12
PA Missile:	0	0	0
2nd Attack %:	20	20	20
2A Type:	Physical	Physical	Physical
2A Damage:	3D4+1	3D4+3	3D4+6
2A Missile:	Dagger	Dagger	Dagger
Resist:	F (N), E (N), C (N), P (N), Ph (N), M (N)	F (N), E (N), C (N), P (N), Ph (N), M (N)	F (N), E (N), C (N), P (N), Ph (N), M (N)



Titan Class

STATISTIC	TITAN	NOBLE TITAN	SUPREME TITAN
Attacks as Level:	65	75	85
Hit Points:	617	787	977
Armor Class:	40	50	60
Experience Earned:	4875	6375	9975
Treasure Carried:	200D10+ 40%L5	300D10+ L5	400D10+ L6
Flying:	No	No	No
AI Type:	Aggressive	Aggressive	Aggressive
Attack Speed:	70	70	70
Preferred Enemy:	Female	Female	Female
Special Attack:	Break Item	Break Item	Dead
PA Type:	Electrical	Electrical	Electrical
PA Damage:	2D20+20	2D20+30	2D20+40
PA Missile:	Electrical	Electrical	Electrical
Spell Use %:	30	40	50
Spell:	Psychic Shock	Psychic Shock	Psychic Shock
Resist:	F (SR), E (Imm), C (SR), P (SR), Ph (SR), M (Imm)	F (SR), E (Imm), C (SR), P (SR), Ph (SR), M (Imm)	F (R), E (Imm), C (R), P (R), Ph (R), M (Imm)



CHAPTER 3 KNOW THINE ENEMY: Monsters



M O N S T E R S

Werewolf Class

STATISTIC	WOLFMAN	WEREWOLF	GREATER WEREWOLF
Attacks as Level:	30	35	40
Hit Points:	180	227	280
Armor Class:	20	25	30
Experience Earned:	600	1200	2000
Treasure Carried:	5D20+ 10%L3Misc	10D20+ 10%L4Misc	20D20+ 10%L5Misc
Flying:	No	No	No
AI Type:	Aggressive	Aggressive	Suicidal
Attack Speed:	100	100	80
Preferred Enemy:	Paladin, Cleric	Paladin, Cleric	Paladin, Cleric
Special Attack:	Disease2×2	Disease3×2	Unconscious
PA Type:	Physical	Physical	Physical
PA Damage:	2D12+12	2D12+16	2D12+20
PA Missile:	0	0	0
Resist:	F (N), E (N), C (N), P (N), Ph (N), M (N)	F (N), E (N), C (N), P (N), Ph (N), M (N)	F (SR), E (SR), C (SR), P (SR), Ph (SR), M (SR)





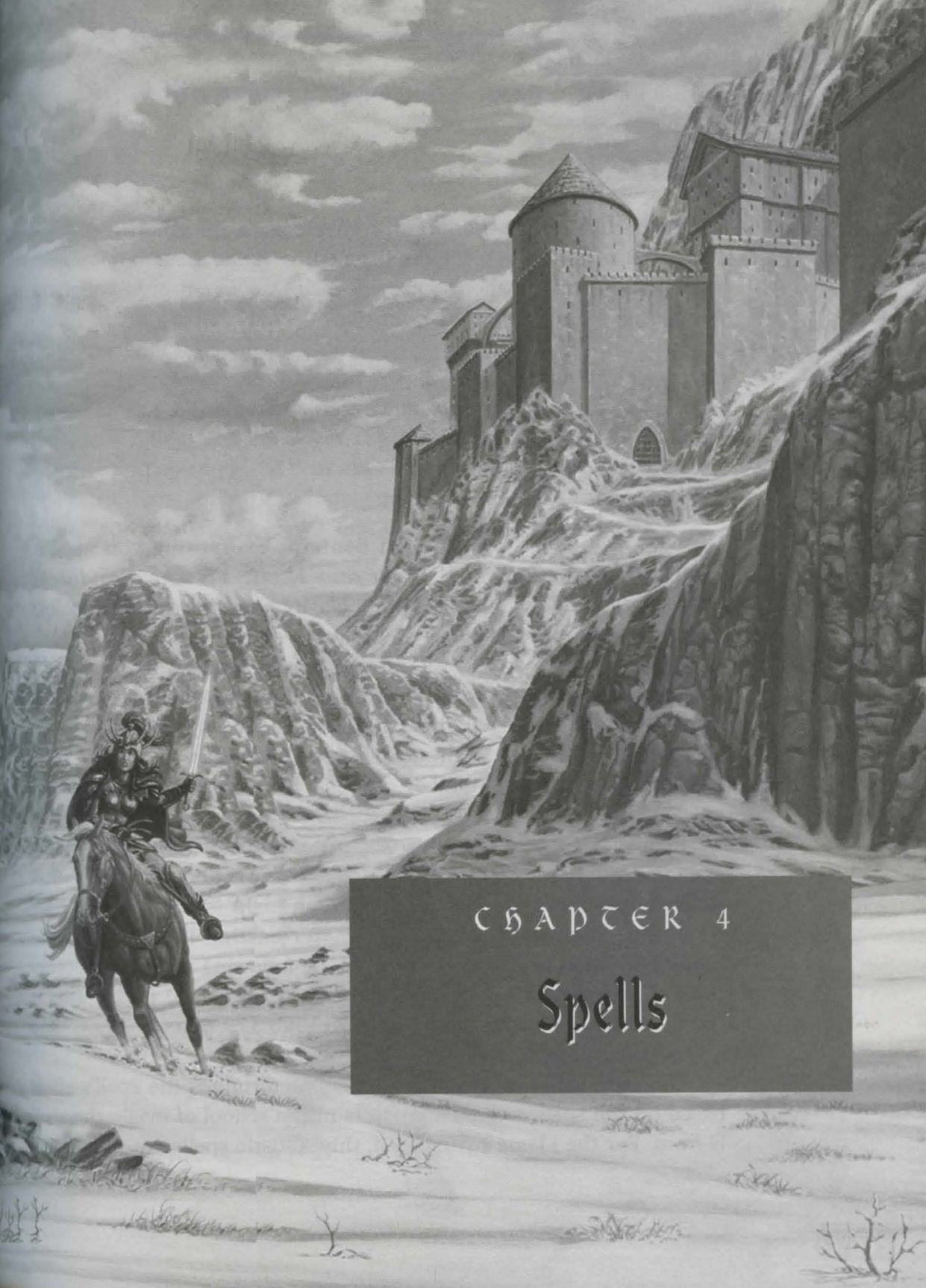

CHAPTER 4

Spells



This section contains everything you need to know about the spells in *Might and Magic VI: The Mandate of Heaven*. The following paragraphs clarify some of the terminology you'll encounter in the tables that follow.

The spell number reflects the spell's placement on its page in the spellbook. Reading left to right and top to bottom, Spell 1 in the Fire Spells section is the spell directly right of the fire symbol, while Spell 11 occupies the lowest, rightmost corner of the page.

Casting cost is the number of mana points expended to cast the spell.

Recovery time is the approximate amount of time it takes the spellcaster to recover before initiating another action. You will notice, for instance, a character who casts Torch Light is very quickly back in action. However, the same character casting Incinerate is not ready for action nearly as quickly. In the following tables, a recovery time of less than 69 units is listed as "very fast," 70 to 99 units is "fast," 100 to 119 units is "average," 120 to 179 units is "slow," and 180 or more units is considered "very slow."

The base skill/skill modifier statistic determines the spell's effect based on the spellcaster's skill points in the school of magic the spell is from. For the Flame Arrow spell, this statistic spells out up to eight



points of damage for a successful hit, and an additional percentage chance for success equal to the spellcaster's skill points in Fire Spell multiplied by 5 percent. Obviously, some monsters are resistant (or even immune) to fire damage, and the damage they take is reduced by their overall resistance.

The Expert result and Master result statistics apply only if the spellcaster has achieved expertise or mastery within the school's skill class, and reflect a bonus over the base skill statistic. To achieve expertise and mastery, the character must undergo training.

Restrictions apply in certain situations. If a spell restriction is "none," you may cast the spell anytime.





Fire Spells

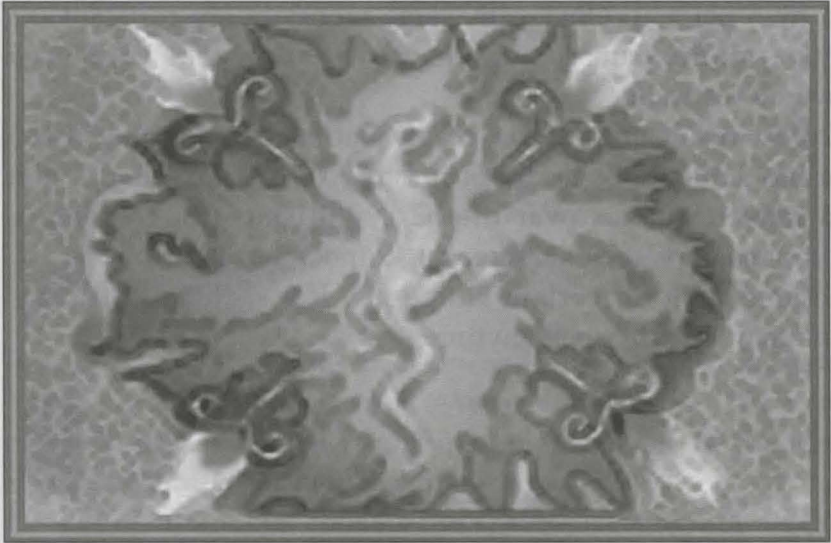

Spell 1: Torch Light

Description:	Increases the radius of light around your party in the dark. The light gets brighter at Expert and Master levels.
Casting Cost:	1
Recovery Time:	Very Fast
Damage Result:	None
Target:	Party
Base Spell/Skill Modifier:	Duration = (skill × 1) hours
Expert Result:	Brighter
Master Result:	Brightest
Restrictions:	None



Spell 2: Flame Arrow



Description:	Creates and fires a single flaming arrow. Unlike most spells, this spell is notoriously inaccurate and has the same chance of hitting as a regular arrow (using your Fire skill as a bonus to hit). Also unlike most spells, casting Flame Arrow is free when you become a Master of Fire.
Casting Cost:	2
Recovery Time:	Average
Damage Result:	Fire
Target:	One enemy
Base Spell/Skill Modifier:	Damage = 1D8 hit points; plus to hit = (skill × 5)
Expert Result:	Casting cost = 1, recovery time = Fast
Master Result:	Casting cost = 0, recovery time = Fast
Restrictions:	None

Spell 3: Protection from Fire



Description:	Increases all your characters' resistance to fire by an amount equal to your skill in Fire magic.
Casting Cost:	3
Recovery Time:	Slow
Damage Result:	None
Target:	Party
Base Spell/Skill Modifier:	Protection = (skill × 1%); duration = (skill × 1) hours
Expert Result:	Protection = (skill × 2%)
Master Result:	Protection = (skill × 3%)
Restrictions:	Not cumulative

Fire Spells

**Spell 4: Fire Bolt****Description:**

Launches a burst of fire at a single target. Damage is moderate, but casting cost is low. Fire Bolt is safe and effective; it is the most reliable spell in the Sorcerer's arsenal.

Casting Cost:	4
Recovery Time:	Fast
Damage Result:	Fire
Target:	One enemy
Base Spell/Skill Modifier:	Damage = (1D4 × skill) hit points
Expert Result:	Recovery time = Fast
Master Result:	Recovery time = Fast
Restrictions:	None

**Spell 5: Haste****Description:**

Reduces the time it takes to recover from casting a spell or attacking with a weapon. Characters will be weak after this spell wears off.

Casting Cost:	5
Recovery Time:	Slow
Damage Result:	None
Target:	One party member
Base Spell/Skill Modifier:	Recovery time = faster; duration = (4 + skill) minutes
Expert Result:	Casts spell on entire party
Master Result:	Casts spell on entire party; duration = 1 hour + (skill × 3) minutes
Restrictions:	No party members in a weakened state

**Spell 6: Fireball**

Description:	Another Sorcerer's favorite, Fireball targets a single monster, but hurts anyone caught in the blast. If your party is too close, they'll be hurt as well.
Casting Cost:	8
Recovery Time:	Average
Damage Result:	Fire
Target:	One enemy + radial damage
Base Spell/Skill Modifier:	Damage = (1D6 × skill) hit points, 256-unit radius
Expert Result:	Recovery time = Fast
Master Result:	Recovery time = Fast
Restrictions:	None

**Spell 7: Ring of Fire**

Description:	Generates a ring of fire around the party that damages all monsters it contacts. Happily, Ring of Fire won't damage <i>your</i> characters.
Casting Cost:	10
Recovery Time:	Average
Damage Result:	Fire
Target:	All monsters within range of the spell's effective radius
Base Spell/Skill Modifier:	Damage = (skill + 6) hit points, 128-unit radius
Expert Result:	Radius × 2
Master Result:	Recovery time = Fast
Restrictions:	None

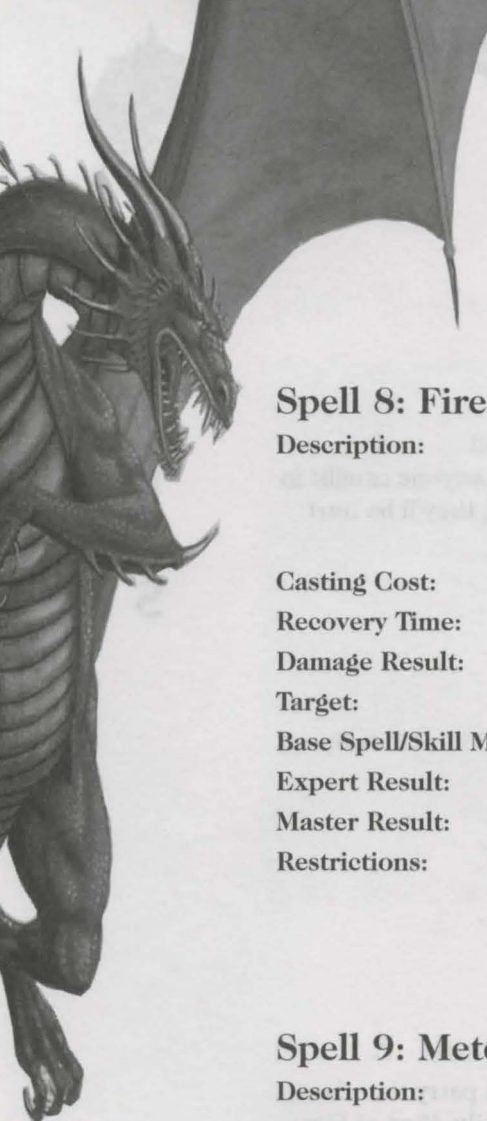

Spell 8: Fire Blast

Description:	Launches streaks of fire in the direction the characters are facing. The bolts hit only monsters that stand in their way, so a little aiming practice will help you benefit most from Fire Blast.
Casting Cost:	15
Recovery Time:	Average
Damage Result:	Fire
Target:	Forward, with multiple missiles
Base Spell/Skill Modifier:	Damage = $(4 + (1D3 \times \text{skill}))$ hit points, three shots
Expert Result:	Recovery time = Fast, five shots
Master Result:	Recovery time = Fast, seven shots
Restrictions:	None



Spell 9: Meteor Shower

Description:	Summons flaming rocks from the sky in a large radius around your target. Try not to be near the target when you use this spell.
Casting Cost:	20
Recovery Time:	Slow
Damage Result:	Fire
Target:	One enemy + radius around enemy
Base Spell/Skill Modifier:	Damage = $(8 + \text{skill})$ hit points, 256-unit radius, eight rocks
Expert Result:	Recovery time = Average, 12 rocks
Master Result:	Recovery time = Slow, 16 rocks
Restrictions:	Outdoors

**Spell 10: Inferno****Description:**

Burns all monsters in sight, excluding your characters. Good for cleaning out rooms full of weak or moderate-strength monsters in one or two easy castings.

Casting Cost:

25

Recovery Time:

Slow

Damage Result:

Fire

Target:

All enemies in view

Base Spell/Skill Modifier:

Damage = (12 + skill) hit points

Expert Result:

Recovery time = Slow

Master Result:

Recovery time = Average

Restrictions:

Indoor

**Spell 11: Incinerate****Description:**

One of the game's strongest direct-damage spells, Incinerate inflicts massive damage on a single target. Only the strongest of monsters can expect to survive this spell.

Casting Cost:

30

Recovery Time:

Slow

Damage Result:

Fire

Target:

One enemy

Base Spell/Skill Modifier:

Damage = (15 + [1D15 × skill]) hit points

Expert Result:

Recovery time = Slow

Master Result:

Recovery time = Fast

Restrictions:

None

Air Spells



Spell 1: Wizard Eye

Description:	Wizard Eye causes the Automap in the upper-right corner of the main gaming screen to display the locations of monsters and other points of interest while outdoors.
Casting Cost:	1
Recovery Time:	Very Fast
Damage Result:	None
Target:	Party
Base Spell/Skill Modifier:	Show Creatures/NPCs; duration = (skill × 1) hours
Expert Result:	Show Treasure
Master Result:	Show Events
Restrictions:	None



Spell 2: Static Charge

Description:	Targets a single monster with a jolt of static electricity. It doesn't do much damage, but it always hits. The more skill you have in Air Magic, the faster you'll recover from casting Static Charge. Masters of Air can cast this spell without cost.
Casting Cost:	2
Recovery Time:	Average
Damage Result:	Electricity
Target:	One enemy
Base Spell/Skill Modifier:	Damage = (1D5 + 1) hit points; recovery time = (base - skill)
Expert Result:	Recovery time = Fast
Master Result:	Casting cost = 0
Restrictions:	None

Spell 3: Protection from Electricity

Description:	Increases all your characters' resistance to electricity by an amount equal to your skill in Air Magic.
Casting Cost:	3
Recovery Time:	Slow
Damage Result:	None
Target:	Party
Base Spell/Skill Modifier:	Protection = skill × 1%; duration = (skill × 1) hours
Expert Result:	Protection = (skill × 2%)
Master Result:	Protection = (skill × 3%)
Restrictions:	Not cumulative

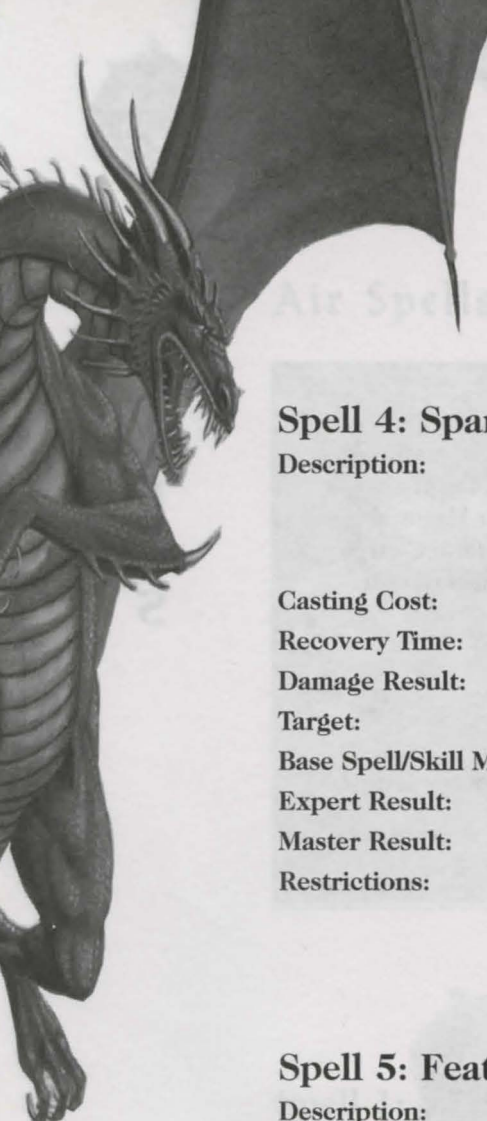

Spell 4: Sparks

Description:

Sparks fly from small balls of lightning that bounce around until they hit something or dissipate. It's hard to tell where they'll go, so this spell is best used in a room crowded with small monsters.

Casting Cost:

4

Recovery Time:

Fast

Damage Result:

Electricity

Target:

Forward, with multiple missiles

Base Spell/Skill Modifier:

Damage = (skill + 2) hit points, three shots

Expert Result:

Recovery time = Fast, five shots

Master Result:

Recovery time = Fast, seven shots

Restrictions:

None



Spell 5: Feather Fall

Description:

Prevents your characters from being hurt when falling more than 10 feet by slowing the rate of descent. Feather Fall affects your entire party with one casting and has a duration based on your skill in Air Magic.

Casting Cost:

5

Recovery Time:

Slow

Damage Result:

None

Target:

Party

Base Spell/Skill Modifier:

Duration = (skill × 5) minutes

Expert Result:

Duration = (skill × 10) minutes

Master Result:

Duration = (skill × 1) hours

Restrictions:

Not cumulative



Spell 6: Shield



Description:	Halves damage from incoming ranged attacks (such as rocks and arrows) by slowing the missiles down just before they hit.
Casting Cost:	8
Recovery Time:	Slow
Damage Result:	None
Target:	One party member
Base Spell/Skill Modifier:	Protection = (1/2 damage from missiles); duration = 1 hour + (5 × skill) minutes
Expert Result:	Casts spell on entire party
Master Result:	Casts spell on entire party; duration = 1 hour + (15 × skill) minutes
Restrictions:	Not cumulative

Spell 7: Lightning Bolt



Description:	The "Sorcerer's darling," Lightning Bolt discharges electricity from the caster's hand to a single target. It always hits and does solid damage.
Casting Cost:	10
Recovery Time:	Average
Damage Result:	Electricity
Target:	One enemy
Base Spell/Skill Modifier:	Damage = (1D8 × skill) hit points
Expert Result:	Recovery time = Fast
Master Result:	Recovery time = Fast
Restrictions:	None

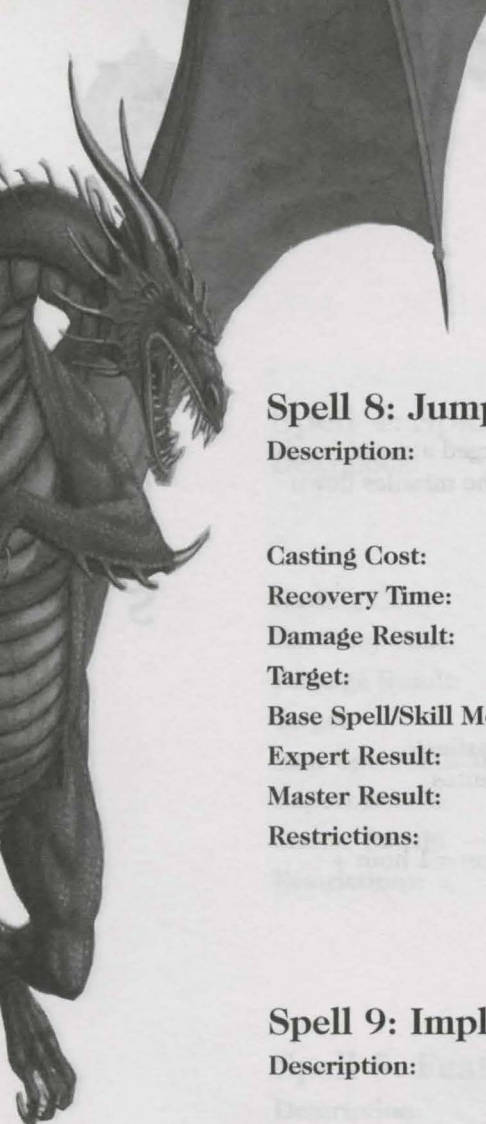

Spell 8: Jump

Description:	Jump launches your party into the air, landing them 60 feet from where they started. Your party takes no falling damage from the jump.
Casting Cost:	15
Recovery Time:	Average
Damage Result:	None
Target:	Party
Base Spell/Skill Modifier:	Recovery time = (base - skill)
Expert Result:	Recovery time = Fast
Master Result:	Recovery time = Fast
Restrictions:	None

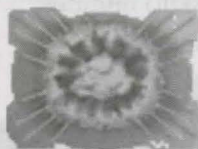

Spell 9: Implosion

Description:	Implosion is a nasty spell that affects a single target by destroying the air around it, causing a sudden inrush from the surrounding air, a thunderclap, and a lot of damage.
Casting Cost:	20
Recovery Time:	Slow
Damage Result:	Physical
Target:	One enemy
Base Spell/Skill Modifier:	Damage = (10 + [1D10 × skill]) hit points
Expert Result:	Recovery time = Average
Master Result:	Recovery time = Fast
Restrictions:	None



Spell 10: Fly



Description:	Grants the power of flight to your characters! This spell is expensive and works only outdoors, but it's very useful. Enjoy.
Casting Cost:	25
Recovery Time:	Very Slow
Damage Result:	None
Target:	Party
Base Spell/Skill Modifier:	Duration = (skill × 5) minutes, drain one spell point every five minutes
Expert Result:	Duration = (skill × 10) minutes
Master Result:	Duration = (skill × 1) hours
Restrictions:	Outdoors

Spell 11: Starburst

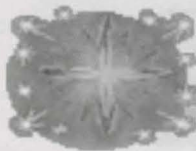

Description:	Calls stars from the heavens to smite and burn your enemies. Expert and Master ranking in this spell both increase the number of stars called and shorten recovery time. Try not to get caught in the blast!
Casting Cost:	30
Recovery Time:	Slow
Damage Result:	Electricity
Target:	One enemy+radius around enemy
Base Spell/Skill Modifier:	Damage = (20 + skill) hit points, 512-unit radius, eight stars
Expert Result:	Recovery time = Slow, 12 stars
Master Result:	Recovery time = Average, 16 stars
Restrictions:	Outdoors

Water Spells

**Spell 1: Awaken**

Description:	Automatically awakens all your characters from normal sleep and will awaken them from a magical sleep if they haven't had the sleep condition for too long. The greater your skill in Water Magic, the longer the sleep condition can have been present before this spell becomes ineffective.
Casting Cost:	1
Recovery Time:	Very Fast
Damage Result:	None
Target:	Party
Base Spell/Skill Modifier:	Asleep (duration - [skill × 3]) minutes
Expert Result:	Asleep (duration - [skill × 1]) hours
Master Result:	Asleep (duration - [skill × 1]) days
Restrictions:	None



Spell 2: Cold Beam

Description:	Targets a single monster with a field of extreme cold for an instant. It doesn't do much damage, but it always hits. The more skill you have in Water Magic, the faster you'll recover from casting Cold Beam. Masters of Water can cast this spell without cost.
Casting Cost:	2
Recovery Time:	Fast
Damage Result:	Cold
Target:	One enemy
Base Spell/Skill Modifier:	Damage = 2D3 hit points; recovery time = (base - skill)
Expert Result:	Recovery time = Fast
Master Result:	Casting cost = 0
Restrictions:	None



Spell 3: Protection from Cold

Description:	Increases all your characters' resistance to cold by an amount equal to your skill in Water Magic.
Casting Cost:	3
Recovery Time:	Slow
Damage Result:	None
Target:	Party
Base Spell/Skill Modifier:	Protection = (skill × 1%); duration = (skill × 1) hours
Expert Result:	Protection = (skill × 2%)
Master Result:	Protection = (skill × 3%)
Restrictions:	Not cumulative

Water Spells

**Spell 4: Poison Spray**

Description:	Sprays poison at monsters directly in front of your characters. Damage is low, but few monsters have resistance to poison, so it usually works.
Casting Cost:	4
Recovery Time:	Average
Damage Result:	Poison
Target:	Forward, with multiple missiles
Base Spell/Skill Modifier:	Damage = $(2 + [1D2 \times \text{skill}])$ hit points, one shot
Expert Result:	Recovery time = Fast, three shots
Master Result:	Recovery time = Fast, five shots
Restrictions:	None

**Spell 5: Water Walk**

Description:	Useful only outdoors, Water Walk lets your characters walk along the surface of water without sinking. This spell can be very useful, but constantly drains spell points while active.
Casting Cost:	5
Recovery Time:	Slow
Damage Result:	None
Target:	Party
Base Spell/Skill Modifier:	Duration = $(\text{skill} \times 5)$ minutes, drain one spell point every 20 minutes
Expert Result:	Duration = $(\text{skill} \times 10)$ minutes
Master Result:	Duration = $(\text{skill} \times 1)$ hours
Restrictions:	Outdoors

**Spell 6: Ice Bolt**

Description:	Fires a single bolt of ice at a single target. It always hits and does moderate cold damage.
Casting Cost:	8
Recovery Time:	Average
Damage Result:	Cold
Target:	One enemy
Base Spell/Skill Modifier:	Damage = $(1D7 \times \text{skill})$ hit points
Expert Result:	Recovery time = Fast
Master Result:	Recovery time = Fast
Restrictions:	None

**Spell 7: Enchant Item**

Description:	Gives a chance to imbue a normal item with magical powers. The greater your skill, the better chance this spell will work. Experts manage better enchantments, and only Masters can enchant weapons.
Casting Cost:	10
Recovery Time:	Slow
Damage Result:	None
Target:	Item
Base Spell/Skill Modifier:	Success rate = $(\text{skill} \times 10\%)$, no weapons, maximum = Second Level
Expert Result:	Maximum = Third Level
Master Result:	Weapons included, maximum = Third Level
Restrictions:	No Quest items

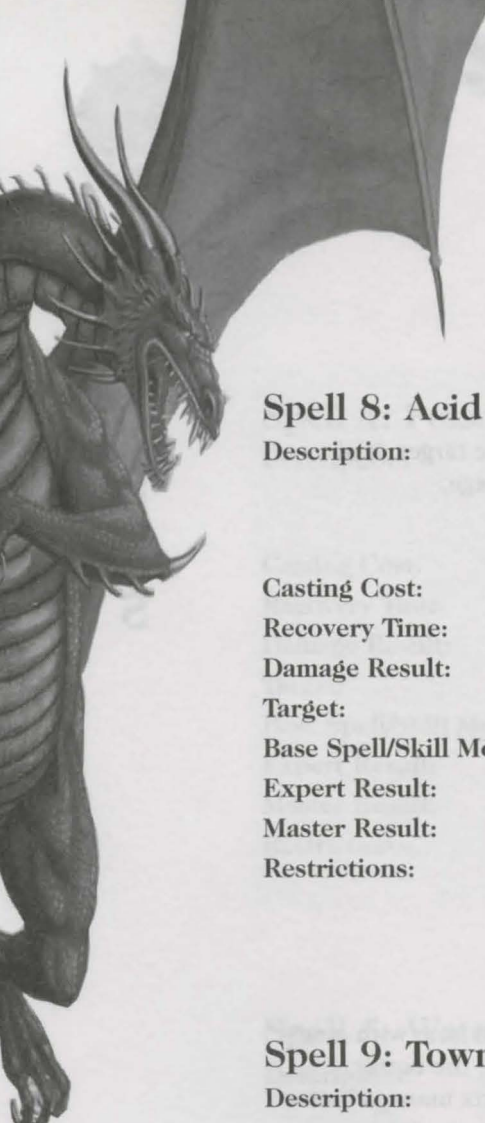

Spell 8: Acid Burst

Description:	Squirts a jet of caustic acid at a single victim. It always hits and does moderate to strong damage. The big advantage of this spell is that few monsters are resistant to acid.
Casting Cost:	15
Recovery Time:	Average
Damage Result:	Poison
Target:	One enemy
Base Spell/Skill Modifier:	Damage = $(9 + [1D9 \times \text{skill}])$ hit points
Expert Result:	Recovery time = Average
Master Result:	Recovery time = Fast
Restrictions:	None



Spell 9: Town Portal

Description:	Has a 10 percent chance per point of Water magic skill of working. At Apprentice rank, Town Portal transports the party to the last town they visited, but only if they're outdoors. Experts can use this spell indoors, and Masters of Water can choose the town they go to.
Casting Cost:	20
Recovery Time:	Very Slow
Damage Result:	None
Target:	Party
Base Spell/Skill Modifier:	Success rate = $(\text{skill} \times 10\%)$, outdoors only
Expert Result:	Indoors OK
Master Result:	Select town
Restrictions:	None

**Spell 10: Ice Blast**

Description:	Fires a ball of ice in the direction the caster is facing. The ball shatters when it hits, launching shards of ice in all directions (except toward the caster). The shards ricochet until they strike a creature or melt.
Casting Cost:	25
Recovery Time:	Slow
Damage Result:	Cold
Target:	Forward, with each shard exploding into seven more shards for explosion damage
Base Spell/Skill Modifier:	Damage = $(12 + [1D2 \times \text{skill}])$ hit points, seven shards
Expert Result:	Recovery time = Average
Master Result:	Recovery time = Fast
Restrictions:	None

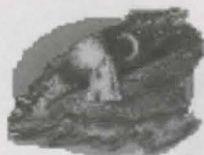
**Spell 11: Lloyd's Beacon**

Description:	Lets you place a marker at a location you want to teleport back to in the future. Just how far in the future depends on your skill and ranking in Water magic. Cast this spell when you wish either to place a marker or to return to one. Apprentices to Water magic may have only one marker at a time; Experts and Masters may have three and five, respectively.
Casting Cost:	30
Recovery Time:	Very Slow
Damage Result:	None
Target:	Party
Base Spell/Skill Modifier:	Duration = $(\text{skill} \times 1)$ hours, one beacon
Expert Result:	Duration = $(\text{skill} \times 1)$ days, three beacons
Master Result:	Duration = $(\text{skill} \times 1)$ weeks, five beacons
Restrictions:	None

Earth Spells



Spell 1: Stun

Description:

Slaps a monster with magical force, forcing it to recover from the Stun spell before it can do anything else. Stun also knocks monsters back a little, giving you a chance to get away while still possible.

Casting Cost:

1

Recovery Time:

Fast

Damage Result:

Magic

Target:

One enemy

Base Spell/Skill Modifier:

Add $(10 + [(skill \times 2)])$ to enemy's recovery time

Expert Result:

Add $(10 + [skill \times 3])$ to enemy's recovery time

Master Result:

Add $(10 + [skill \times 4])$ to enemy's recovery time

Restrictions:

None



Spell 2: Magic Arrow

Description:	Creates and fires a single, magical arrow. Unlike most spells, this spell is inaccurate and has the same chance of hitting as a regular arrow (using your Earth magic skill as a bonus to hit). Also, unlike most spells, Magic Arrow is free to cast when you become a Master of Earth.
Casting Cost:	2
Recovery Time:	Fast
Damage Result:	Physical
Target:	One enemy
Base Spell/Skill Modifier:	Damage = (1D6 + 2) hit points; plus to hit = (skill × 5)
Expert Result:	Casting cost = 1; recovery time = Fast
Master Result:	Casting cost = 0; recovery time = Fast
Restrictions:	None



Spell 3: Protection from Magic

Description:	Increases all your characters' resistance to magic by an amount equal to your skill in Earth magic.
Casting Cost:	3
Recovery Time:	Slow
Damage Result:	None
Target:	Party
Base Spell/Skill Modifier:	Protection = (skill × 1%); duration = (skill × 1) hours
Expert Result:	Protection = (skill × 2%)
Master Result:	Protection = (skill × 3%)
Restrictions:	Not cumulative

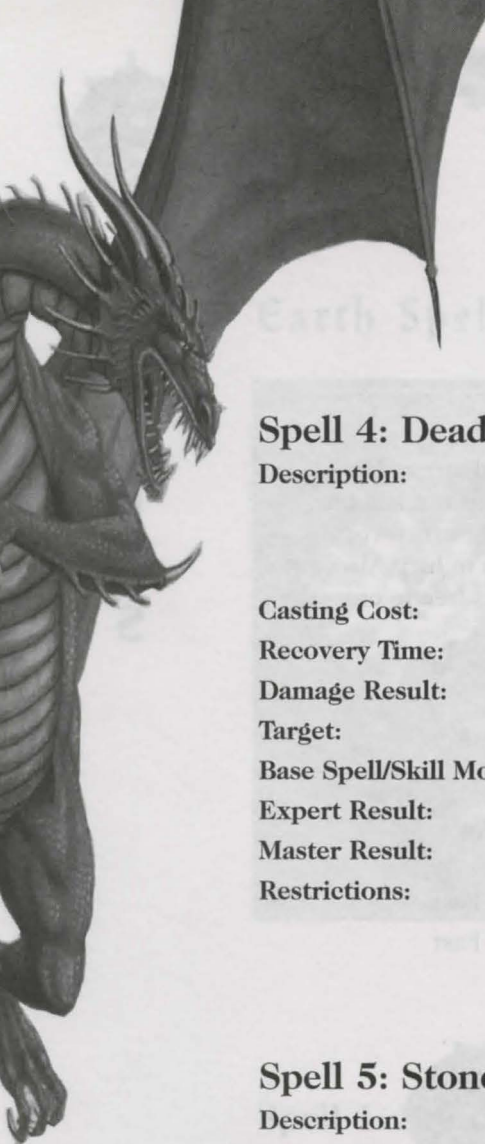

Earth Spells



Spell 4: Deadly Swarm

Description:	Summons a swarm of biting, stinging insects to bedevil a single target. The swarm does moderate damage, but it never misses and the damage is physical, making resistance to this spell unlikely.
Casting Cost:	4
Recovery Time:	Average
Damage Result:	Physical
Target:	One enemy
Base Spell/Skill Modifier:	Damage = $(5 + [1D3 \times \text{skill}])$ hit points
Expert Result:	Recovery time = 90
Master Result:	Recovery time = 80
Restrictions:	None



Spell 5: Stone Skin

Description:	Increases the armor class of a character by $5 + (\text{skill} \times 1)$ for the duration of the spell.
Casting Cost:	5
Recovery Time:	Slow
Damage Result:	None
Target:	One party member
Base Spell/Skill Modifier:	Armor class + $(5 + [\text{skill}])$; duration = 1 hour + $(\text{skill} \times 5)$ minutes
Expert Result:	Party
Master Result:	Duration = $(4 + [\text{skill} \times 15])$ minutes
Restrictions:	Not cumulative



Spell 6: Blades



Description:	Fires a rotating, razor-like metal blade at a single monster. This spell can miss, with damage and chance to hit relying heavily on Earth magic skill.
Casting Cost:	8
Recovery Time:	Average
Damage Result:	Physical
Target:	One enemy
Base Spell/Skill Modifier:	Damage = (1D5 × skill) hit points; plus to hit = (skill × 5)
Expert Result:	Recovery time = Fast
Master Result:	Recovery time = Fast
Restrictions:	None



Spell 7: Stone to Flesh

Description:	Removes the stone condition from a character if you cast this spell in time. The greater the skill and rank in Earth magic, the longer the condition can have been present before the “point of no return.” After that, the only way to remove the condition, short of Divine Intervention, is to visit a temple.
Casting Cost:	10
Recovery Time:	Slow
Damage Result:	None
Target:	One party member
Base Spell/Skill Modifier:	Stone (Duration – [skill × 3]) minutes
Expert Result:	Stone (Duration – [skill × 1]) hours
Master Result:	Stone (Duration – [skill × 1]) days
Restrictions:	None

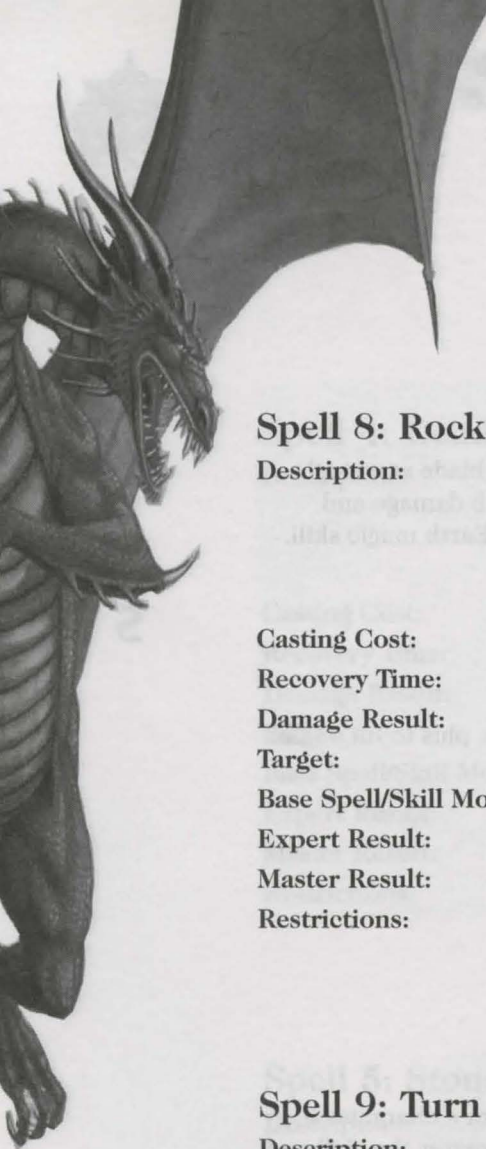

Spell 8: Rock Blast

Description:	Releases a magical stone that explodes when it comes into contact with a creature or after enough time passes. The rock will bounce and roll until it finds a resting spot, so take care not to get caught in the blast.
Casting Cost:	15
Recovery Time:	Average
Damage Result:	Physical
Target:	Forward, with timer delay
Base Spell/Skill Modifier:	Damage = $(1D8 \times \text{skill})$ hit points, 512-unit radius
Expert Result:	Recovery time = Average
Master Result:	Recovery time = Fast
Restrictions:	None



Spell 9: Turn to Stone

Description:	Temporarily turns a target to stone. These stone statues are invulnerable to any sort of attack.
Casting Cost:	20
Recovery Time:	Slow
Damage Result:	Magic
Target:	One enemy
Base Spell/Skill Modifier:	Duration = $(\text{skill} \times 5)$ minutes
Expert Result:	Duration = $(\text{skill} \times 10)$ minutes
Master Result:	Duration = $(\text{skill} \times 20)$ minutes
Restrictions:	None



Spell 10: Death Blossom



Description:	Fires a magical stone far into the air that creates a very large and powerful explosion when it lands. Expert and Master ranking in Earth magic create larger explosions. This spell can only be cast outdoors.
Casting Cost:	25
Recovery Time:	Slow
Damage Result:	Physical
Target:	Launches outward (no specific target), then has blast radius
Base Spell/Skill Modifier:	Damage = (20 + skill), 1024-unit radius
Expert Result:	Recovery time = Average, 1536-unit radius
Master Result:	Recovery time = Average, 2048-unit radius
Restrictions:	Outdoors

Spell 11: Mass Distortion



Description:	Increases the weight of a single target enormously for an instant, causing internal damage equal to 25 percent of the monster's hit points plus another 2 percent per point of skill in Earth magic. The bigger they are, the harder they fall.
Casting Cost:	30
Recovery Time:	Slow
Damage Result:	Magic
Target:	One enemy
Base Spell/Skill Modifier:	Damage = (25 + [Skill × 2])% of enemy's existing hit points
Expert Result:	Recovery time = Slow
Master Result:	Recovery time = Average
Restrictions:	None



Spirit Spells

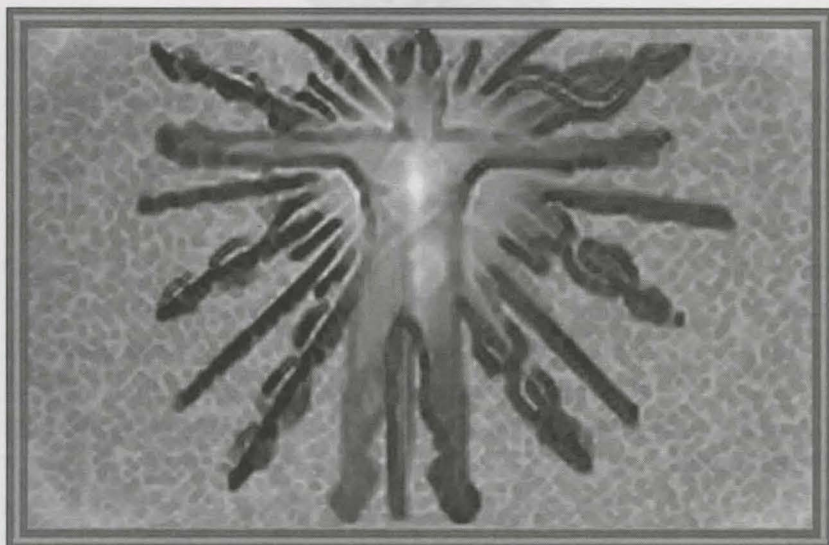

Spell 1: Spirit Arrow

Description:	Fires an ectoplasmic bolt of negative spiritual energy at a single target. Spirit arrow can miss, but a higher skill in Spirit magic increases your chances of hitting. Masters can cast this spell with no spell point cost.
Casting Cost:	1
Recovery Time:	Fast
Damage Result:	Magic
Target:	One enemy
Base Spell/Skill Modifier:	Damage = 1D6 hit points; plus to hit = (skill × 5)
Expert Result:	Recovery time = Fast
Master Result:	Casting cost = 0
Restrictions:	None

**Spell 2: Bless**

Description:	Blessed characters have an increased chance to hit monsters in hand-to-hand combat and with missiles. A character's bonus to hit increases by (skill of caster + 5)%.
Casting Cost:	2
Recovery Time:	Average
Damage Result:	None
Target:	One party member
Base Spell/Skill Modifier:	To hit = (skill + 5)%; duration = 1 hour + (skill × 5) minutes
Expert Result:	Cast spell on entire party
Master Result:	Cast spell on entire party; duration = 1 hour + (skill × 15) minutes
Restrictions:	Not cumulative

**Spell 3: Healing Touch**

Description:	Cheaply heals a single character of a small number of hit points. Mastery level increases this spell's healing factor.
Casting Cost:	3
Recovery Time:	Average
Damage Result:	None
Target:	One party member
Base Spell/Skill Modifier:	Heal = (2D3 + 1) hit points; recovery time = (base-skill)
Expert Result:	Heal = (2D3 + 3) hit points
Master Result:	Heal = (2D3 + 5) hit points
Restrictions:	None

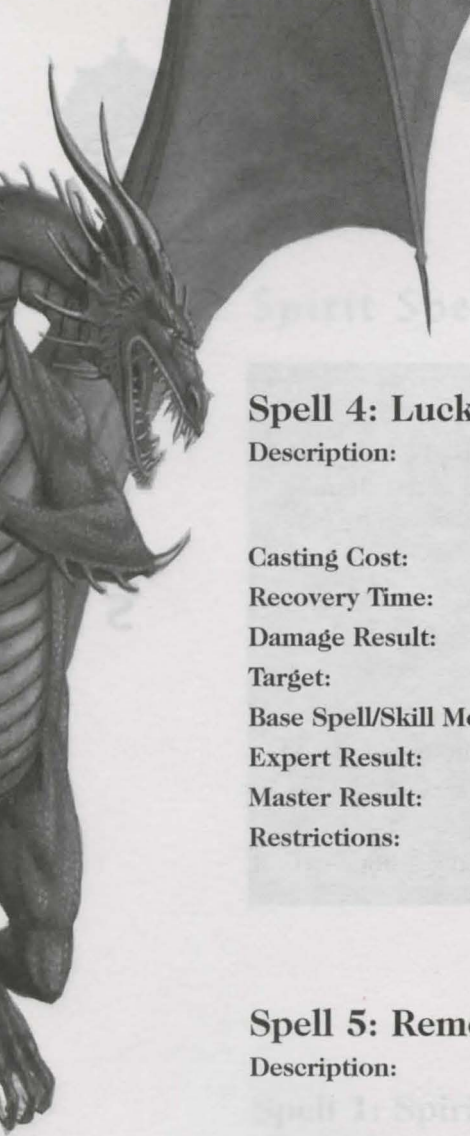

Spell 4: Lucky Day



Description:	Temporarily increases a single character's Luck statistic. If caster is a Master of Spirit Magic, increases entire party's Luck.
Casting Cost:	4
Recovery Time:	Slow
Damage Result:	None
Target:	One party member
Base Spell/Skill Modifier:	Luck = (10 + [skill × 2])
Expert Result:	Luck = (10 + [skill × 3])
Master Result:	Cast spell on entire party
Restrictions:	Not cumulative

Spell 5: Remove Curse



Description:	Removes the cursed condition from a character if you cast this spell in time. The greater the skill and rank in Spirit magic, the longer the condition can have been present before the "point of no return." After that, the only way to remove the condition, short of Divine Intervention, is to visit a temple.
Casting Cost:	5
Recovery Time:	Slow
Damage Result:	None
Target:	One party member
Base Spell/Skill Modifier:	Curse (duration - [skill × 3]) minutes
Expert Result:	Curse (Duration - [skill × 1]) hours
Master Result:	Curse (Duration - [skill × 1]) days
Restrictions:	None



Spell 6: Guardian Angel

Description:	Sets up a compact with the Higher Powers to resurrect your characters upon their deaths and return them to the last temple you visited. The price for this service is half the gold your characters have with them at the time of death.
Casting Cost:	8
Recovery Time:	Slow
Damage Result:	None
Target:	Party
Base Spell/Skill Modifier:	Duration = (skill \times 1) hours, set unconscious party members to one hit point
Expert Result:	Set to one-half total hit points
Master Result:	Set to full hit points
Restrictions:	None



Spell 7: Heroism

Description:	Heroism increases the damage of a character's successful attack by (skill of caster + 5)%.
Casting Cost:	10
Recovery Time:	Slow
Damage Result:	None
Target:	One party member
Base Spell/Skill Modifier:	Damage + (5 + [skill]); duration = 1 hour + (skill \times 5) minutes
Expert Result:	Casts spell on entire party
Master Result:	Casts spell on entire party; duration = 1 hour +(skill \times 15) minutes
Restrictions:	Not cumulative

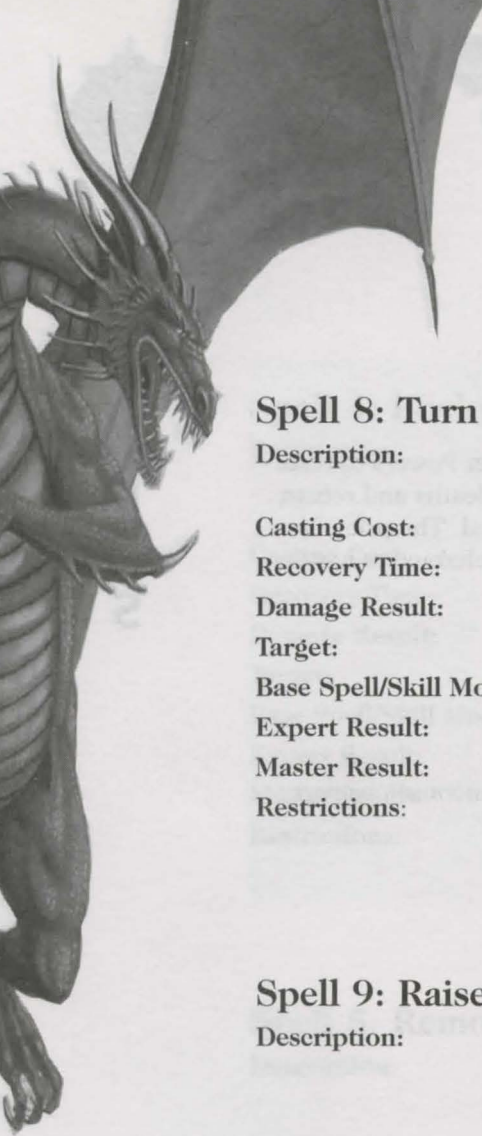

Spell 8: Turn Undead

Description:	Forces all Undead monsters the caster can see to flee until its time runs out.
Casting Cost:	15
Recovery Time:	Slow
Damage Result:	Magic
Target:	All enemies within view
Base Spell/Skill Modifier:	Duration = $(3 + [\text{skill} \times 3])$ minutes
Expert Result:	Recovery time = Slow
Master Result:	Recovery time = Average
Restrictions:	Undead only



Spell 9: Raise Dead

Description:	Raises a character from the dead if you cast this spell in time. The greater the skill and rank in Spirit magic, the longer the character can have been dead before the "point of no return." After that, the only way to raise the character, short of Divine Intervention, is to visit a temple. This spell leaves the target in weakened condition.
Casting Cost:	20
Recovery Time:	Very Slow
Damage Result:	None
Target:	One party member
Base Spell/Skill Modifier:	Dead (duration - $[\text{skill} \times 3]$) minutes
Expert Result:	Dead (duration - $[\text{skill} \times 1]$) hours
Master Result:	Dead (duration - $[\text{skill} \times 1]$) days
Restrictions:	None



Spell 10: Shared Life

Description:

Combines your characters' life force and redistributes it among them as evenly as possible. All current hit points are totaled and extra points based on your skill in Spirit magic accrue to this total. Then the points are distributed back to the characters; no individual character is allowed to have more points than his maximum total hit points.

Casting Cost:

25

Recovery Time:

Slow

Damage Result:

None

Target:

Party

Base Spell/Skill Modifier:

Health = $([\text{total party} + \text{skill}] \div \text{party members})$ hit points

Expert Result:

Health = $([\text{total party} + \{\text{skill} \times 2\}] \div \text{party members})$ hit points

Master Result:

Health = $([\text{total party} + \{\text{skill} \times 3\}] \div \text{party members})$ hit points

Restrictions:

None



Spell 11: Resurrection

Description:

Resurrects an eradicated (body destroyed) character if you cast this spell in time. The greater the skill and rank in Spirit magic, the longer the condition can have been present before the "point of no return." After that, the only way to resurrect the character is to visit a temple. This spell leaves the target in weakened condition.



Casting Cost:	30
Recovery Time:	Extremely Slow
Damage Result:	None
Target:	One party member
Base Spell/Skill Modifier:	Eradicated (duration – [skill × 3]) minutes
Expert Result:	Eradicated (duration – [skill × 1]) hours
Master Result:	Eradicated (duration – [skill × 1]) days
Restrictions:	None

Mind Spells





Spell 1: Meditation



Description:	Temporarily increases a single character's Personality and Intellect statistics. Masters of Mind magic cast this spell on the entire party.
Casting Cost:	1
Recovery Time:	Slow
Damage Result:	None
Target:	One party member
Base Spell/Skill Modifier:	Increase = $(10 + [\text{skill} \times 2])$
Expert Result:	Increase = $(10 + [\text{skill} \times 3])$
Master Result:	Casts spell on entire party
Restrictions:	Not cumulative

Spell 2: Remove Fear



Description:	Removes the fearful condition from a character if you cast this spell in time. The greater the skill and rank in Mind magic, the longer the condition can have been present before the "point of no return." After that, the only way to remove the condition, short of Divine Intervention, is to visit a temple.
Casting Cost:	2
Recovery Time:	Slow
Damage Result:	None
Target:	One party member
Base Spell/Skill Modifier:	Fear (Duration - $[\text{skill} \times 3]$) minutes
Expert Result:	Fear (Duration - $[\text{skill} \times 1]$) hours
Master Result:	Fear (Duration - $[\text{skill} \times 1]$) days
Restrictions:	None

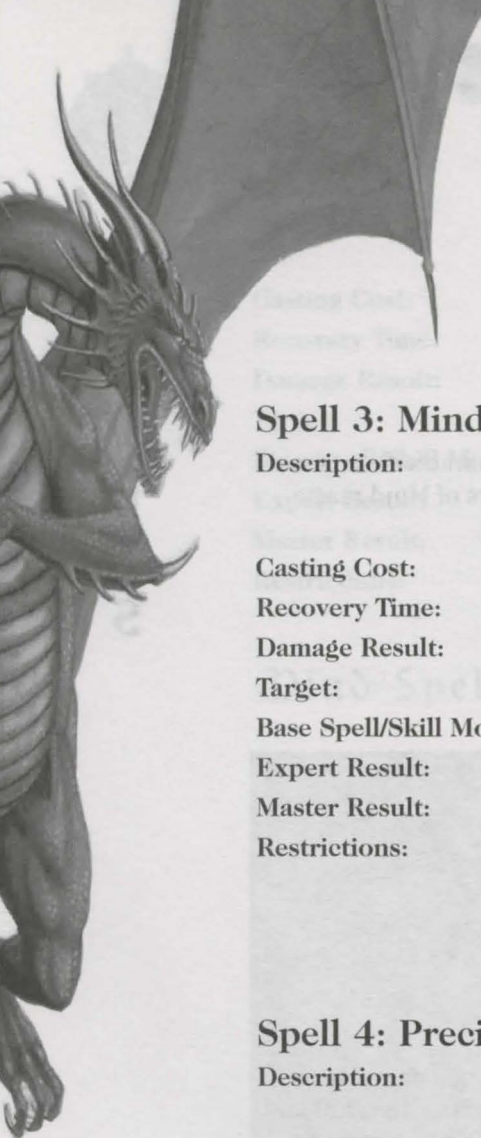

Spell 3: Mind Blast

Description:	Fires a bolt of mental force damaging to a single target's nervous system. Mind Blast does modest damage, but it always hits.
Casting Cost:	3
Recovery Time:	Fast
Damage Result:	Magic
Target:	One enemy
Base Spell/Skill Modifier:	Damage = (5 + [1D2 × skill]) hit points
Expert Result:	Recovery time = Fast
Master Result:	Recovery time = Fast
Restrictions:	None



Spell 4: Precision

Description:	Temporarily increases a single character's Accuracy statistic. Masters of Mind magic cast this spell on the entire party.
Casting Cost:	4
Recovery Time:	Slow
Damage Result:	None
Target:	One party member
Base Spell/Skill Modifier:	Increase = (10 + [skill × 2])
Expert Result:	Increase = (10 + [skill × 3])
Master Result:	Casts spell on entire party
Restrictions:	Not cumulative



Spell 5: Cure Paralysis



Description:	Cures paralysis if you cast this spell in time. The greater the skill and rank in Mind magic, the longer the character can have been paralyzed before the “point of no return.” After that, the only way to remove the condition, short of Divine Intervention, is to visit a temple.
Casting Cost:	5
Recovery Time:	Slow
Damage Result:	None
Target:	One party member
Base Spell/Skill Modifier:	Paralyzed (duration – [skill × 3]) minutes
Expert Result:	Paralyzed (duration – [skill × 1]) hours
Master Result:	Paralyzed (duration – [skill × 1]) days
Restrictions:	None

Spell 6: Charm



Description:	Calms a single targeted creature and removes any hostile feelings it has toward your characters. If this creature takes any damage, it will become hostile again immediately.
Casting Cost:	8
Recovery Time:	Average
Damage Result:	Magic
Target:	One enemy
Base Spell/Skill Modifier:	Duration = (skill × 3) minutes
Expert Result:	Duration = (skill × 6) minutes
Master Result:	Duration = (skill × 12) minutes
Restrictions:	None

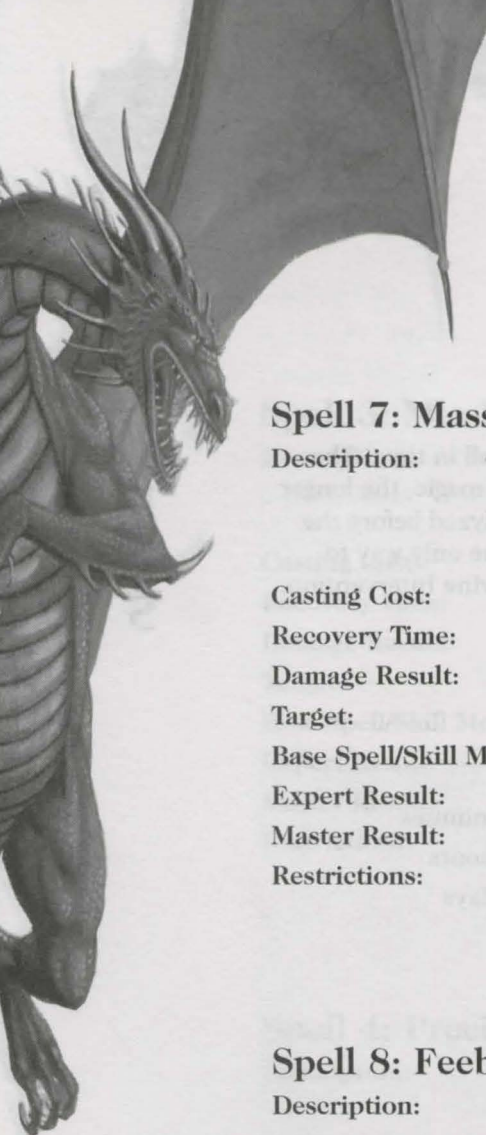

Spell 7: Mass Fear

Description:	All creatures in the caster's sight fear the caster and flee. If a creature takes damage while under the influence of this spell, the spell will be broken. Mass Fear won't work on Undead creatures.
Casting Cost:	10
Recovery Time:	Average
Damage Result:	Magic
Target:	All enemies within view
Base Spell/Skill Modifier:	Duration = (skill × 3) minutes
Expert Result:	Recovery time = Fast
Master Result:	Recovery time = Fast
Restrictions:	None



Spell 8: Feeblemind

Description:	Feeblemind removes a target's ability to cast spells until this spell wears off.
Casting Cost:	15
Recovery Time:	Average
Damage Result:	Magic
Target:	One enemy
Base Spell/Skill Modifier:	Duration = (skill × 5) minutes
Expert Result:	Recovery time = Average
Master Result:	Recovery time = Fast
Restrictions:	None



Spell 9: Cure Insanity



Description:	Cures insanity if you cast this spell in time. The greater the skill and rank in Mind magic, the longer the character can have been insane before the "point of no return." After that, the only way to remove the condition, short of Divine Intervention, is to visit a temple.
Casting Cost:	20
Recovery Time:	Slow
Damage Result:	None
Target:	One party member
Base Spell/Skill Modifier:	Insane (duration - [skill × 3]) minutes
Expert Result:	Insane (duration - [skill × 1]) hours
Master Result:	Insane (duration - [skill × 1]) days
Restrictions:	None

Spell 10: Psychic Shock



Description:	Similar to Mind Blast, Psychic Shock targets a single creature with mind-damaging magic, only to a much greater effect.
Casting Cost:	25
Recovery Time:	Slow
Damage Result:	Magic
Target:	One enemy
Base Spell/Skill Modifier:	Damage = (12 + [1D12 × skill]) hit points
Expert Result:	Recovery time = Average
Master Result:	Recovery time = Average
Restrictions:	None

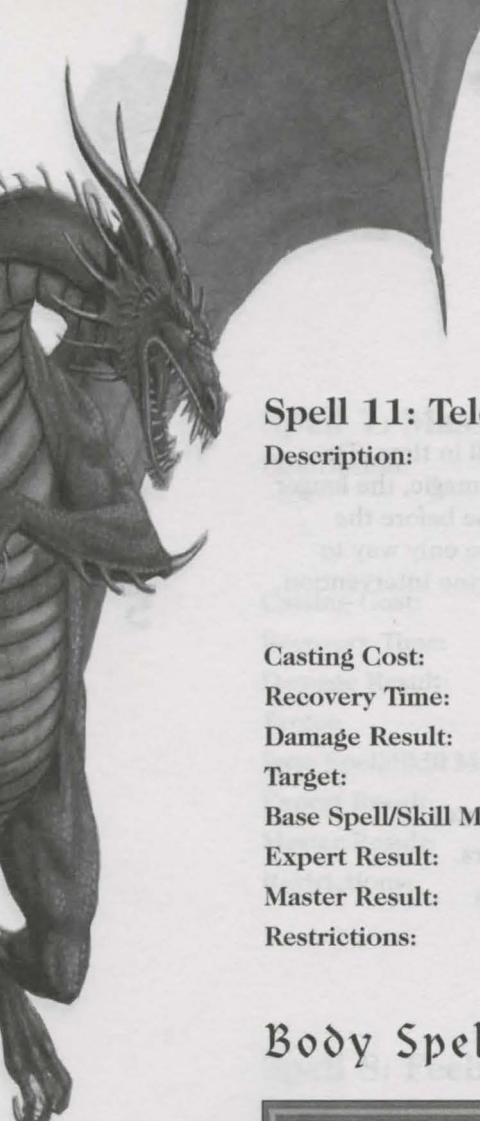

Spell 11: Telekinesis

Description: Lets you manipulate an object at a distance at a strength equal to your character's skill in Mind magic. Switches can be thrown, objects picked up, and doors opened with this spell, all from a nice safe distance from those nasty traps. The target of this spell must be in view.

Casting Cost:	30
Recovery Time:	Very Slow
Damage Result:	None
Target:	Party
Base Spell/Skill Modifier:	Strength = skill
Expert Result:	Strength = (skill × 2)
Master Result:	Strength = (skill × 3)
Restrictions:	None

Body Spells





Spell 1: Cure Weakness



Description:	Cures the weak condition from a character if you cast this spell in time. The greater the skill and rank in Body magic, the longer the character can have been weak before the “point of no return.” After that, the only way to cure the condition, short of Divine Intervention, is to visit a temple.
Casting Cost:	1
Recovery Time:	Slow
Damage Result:	None
Target:	One party member
Base Spell/Skill Modifier:	Weak (duration – [skill × 3]) minutes
Expert Result:	Weak (duration – [skill × 1]) hours
Master Result:	Weak (duration – [skill × 1]) days
Restrictions:	None

Spell 2: First Aid



Description:	Cures a small number of hit points on a single target.
Casting Cost:	2
Recovery Time:	Fast
Damage Result:	None
Target:	One party member
Base Spell/Skill Modifier:	Heal = 5 hit points; recovery time = (base–skill)
Expert Result:	Heal = 7 hit points
Master Result:	Heal = 10 hit points
Restrictions:	None

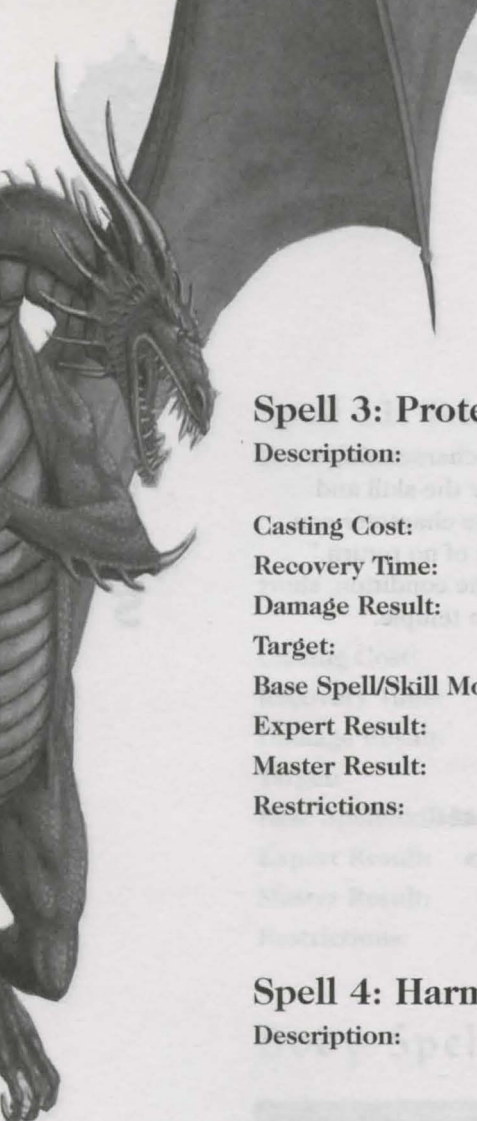

Spell 3: Protection from Poison

Description:	Increases all your characters' resistance to poison by an amount equal to your skill in Body magic.
Casting Cost:	3
Recovery Time:	Slow
Damage Result:	None
Target:	Party
Base Spell/Skill Modifier:	Protection = (skill × 1%); duration = (skill × 1) hours
Expert Result:	Protection = (skill × 2%)
Master Result:	Protection = (skill × 3%)
Restrictions:	Not cumulative



Spell 4: Harm

Description:	Directly inflicts magical damage on a single creature. Harm does only modest damage, but it can't miss.
Casting Cost:	4
Recovery Time:	Average
Damage Result:	Magic
Target:	One enemy
Base Spell/Skill Modifier:	Damage = (8 + [1D2 × skill]) hit points
Expert Result:	Recovery time = Fast
Master Result:	Recovery time = Fast
Restrictions:	None



Spell 5: Cure Wounds



Description:	Cures hit points on a single target. The number cured equals twice your character's skill in Body magic.
Casting Cost:	5
Recovery Time:	Average
Damage Result:	None
Target:	One party member
Base Spell/Skill Modifier:	Heal = $(5 + [\text{skill} \times 2])$ hit points
Expert Result:	Recovery time = Fast
Master Result:	Recovery time = Fast
Restrictions:	None

Spell 6: Cure Poison



Description:	Cures poison in a character if you cast this spell in time. The greater the skill and rank in Body magic, the longer the character can have been poisoned before the "point of no return." After that, the only way to remove the condition, short of Divine Intervention, is to visit a temple.
Casting Cost:	8
Recovery Time:	Slow
Damage Result:	None
Target:	One party member
Base Spell/Skill Modifier:	Poison (duration - $[\text{skill} \times 3]$) minutes
Expert Result:	Poison (duration - $[\text{skill} \times 1]$) hours
Master Result:	Poison (duration - $[\text{skill} \times 1]$) days
Restrictions:	None

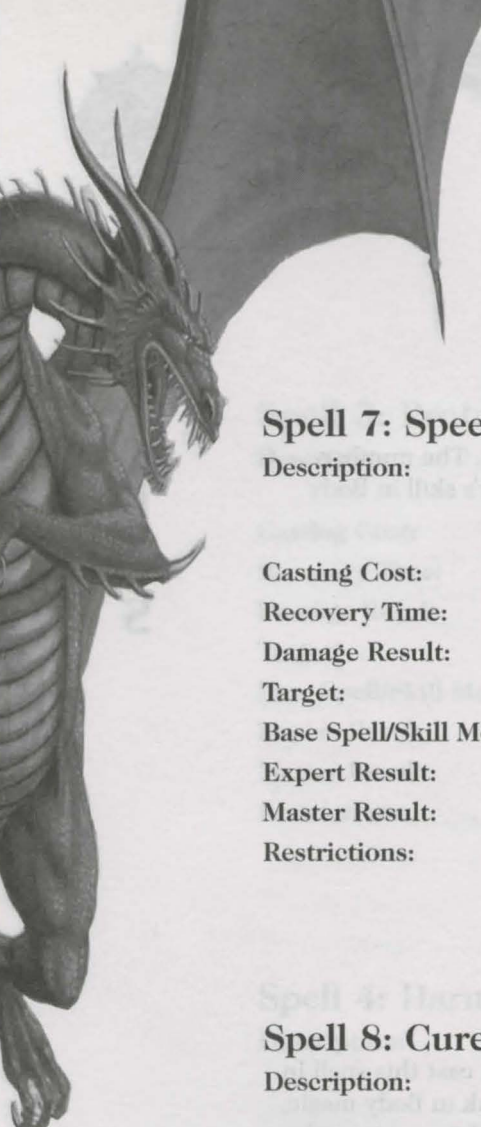

Spell 7: Speed



Description:	Temporarily increases a single character's Speed statistic. Masters of Body Magic cast this spell on the entire party.
Casting Cost:	10
Recovery Time:	Slow
Damage Result:	None
Target:	One party member
Base Spell/Skill Modifier:	Increase = $(10 + [\text{skill} \times 2])$
Expert Result:	Increase = $(10 + [\text{skill} \times 3])$
Master Result:	Casts spell on entire party
Restrictions:	Not cumulative

Spell 8: Cure Disease



Description:	Cures disease in a character if you cast this spell in time. The greater the skill and rank in Body magic, the longer the character can have been diseased before the "point of no return." After that, the only way to remove the condition, short of Divine Intervention, is to visit a temple.
Casting Cost:	15
Recovery Time:	Slow
Damage Result:	None
Target:	One party member
Base Spell/Skill Modifier:	Disease (duration - $[\text{skill} \times 3]$) minutes
Expert Result:	Disease (duration - $[\text{skill} \times 1]$) hours
Master Result:	Disease (duration - $[\text{skill} \times 1]$) days
Restrictions:	None



Spell 9: Power

Description:	Temporarily increases a single character's Might and Endurance statistics. Masters of Body magic cast this spell on the entire party.
Casting Cost:	20
Recovery Time:	Slow
Damage Result:	None
Target:	One party member
Base Spell/Skill Modifier:	Increase = $(10 + [\text{skill} \times 2])$
Expert Result:	Increase = $(10 + [\text{skill} \times 3])$
Master Result:	Casts spell on entire party
Restrictions:	Not cumulative



Spell 10: Flying Fist

Description:	Flying Fist throws a heavy magical force at a single opponent. It does strong physical damage and can't miss.
Casting Cost:	25
Recovery Time:	Slow
Damage Result:	Magic
Target:	One enemy
Base Spell/Skill Modifier:	Damage = $(30 + [1D5 \times \text{skill}])$ hit points
Expert Result:	Recovery time = Slow
Master Result:	Recovery time = Average
Restrictions:	None

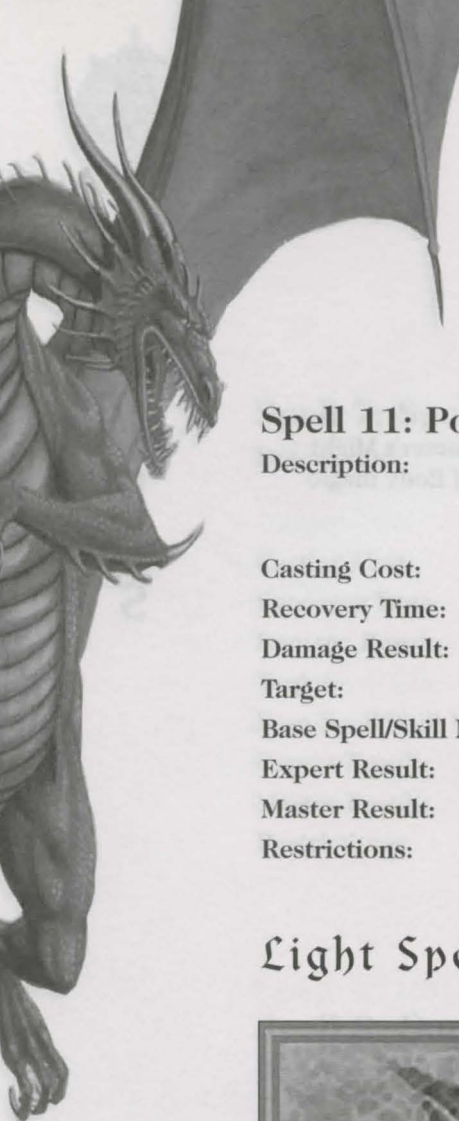

Spell 11: Power Cure

Description:	Cures hit points of all characters in your party at once. The number cured equals twice your character's skill in Body magic.
Casting Cost:	30
Recovery Time:	Slow
Damage Result:	None
Target:	Party
Base Spell/Skill Modifier:	Heal = $(10 + [\text{skill} \times 2])$ hit points
Expert Result:	Recovery time = Slow
Master Result:	Recovery time = Average
Restrictions:	None

Light Spells





Spell 1: Create Food



Description:	Creates food for all your characters if you have less real food than would be created by this spell.
Casting Cost:	20
Recovery Time:	Average
Damage Result:	None
Target:	Party
Base Spell/Skill Modifier:	Creates $(1 + [\text{skill} \div 10])$ food
Expert Result:	Creates $(1 + [\text{skill} \div 5])$ food
Master Result:	Skill creates $(1 + [3 \times \text{skill}] \div 10)$ food
Restrictions:	None

Spell 2: Golden Touch



Description:	Converts a single item you select in your inventory into gold equal to 40 percent of the item's actual value. There is a 10 percent chance per point of skill in Light magic that this spell will succeed. If the spell fails, the item is broken.
Casting Cost:	25
Recovery Time:	Average
Damage Result:	None
Target:	Item
Base Spell/Skill Modifier:	Success rate = $([10 \times \text{Skill}] \%)$ chance; gold = 40% of full value
Expert Result:	Gold = 50% of full value
Master Result:	Gold = 60% of full value
Restrictions:	No Quest item

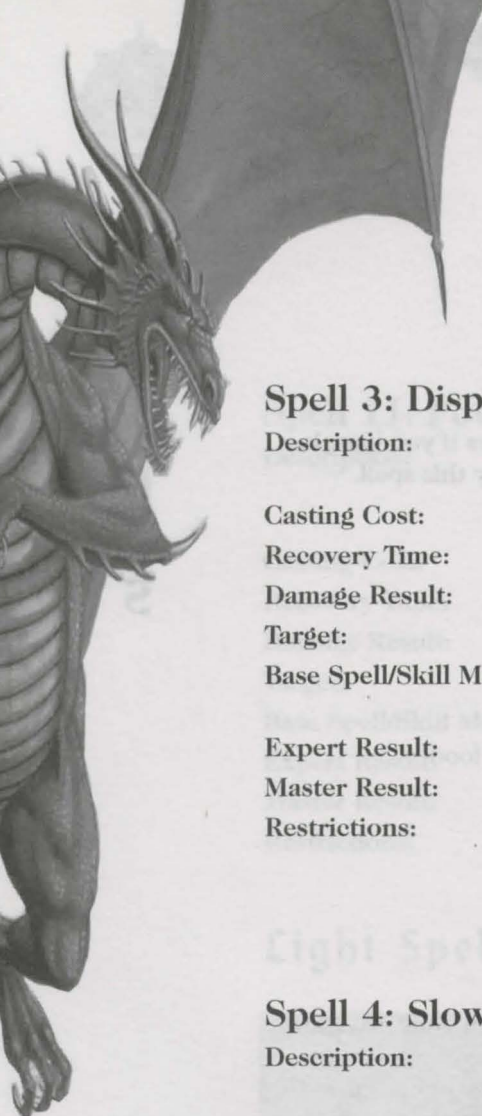

Spell 3: Dispel Magic

Description:	Removes all spells on all creatures, both helpful and harmful, in the caster's sight.
Casting Cost:	30
Recovery Time:	Slow
Damage Result:	None
Target:	All enemies within view
Base Spell/Skill Modifier:	Removes all spell effects, recovery time = (base - skill)
Expert Result:	Recovery time = Average
Master Result:	Recovery time = Average
Restrictions:	None



Spell 4: Slow

Description:	Halves the walking speed and doubles the recovery time of a single monster. Slow ensures a monster will attack you half as often, and will have a harder time catching up to you if you run.
Casting Cost:	35
Recovery Time:	Slow
Damage Result:	Magic
Target:	One enemy
Base Spell/Skill Modifier:	Duration = (skill × 1) minutes
Expert Result:	Recovery time = Average
Master Result:	Recovery time = Fast
Restrictions:	None

**Spell 5: Destroy Undead**

Description:	Calls on the power of Heaven to undo the evil magic that extends the lives of the Undead, inflicting enormous damage on a single, unlucky target. This spell works only on the Undead.
Casting Cost:	40
Recovery Time:	Slow
Damage Result:	Magic
Target:	One enemy
Base Spell/Skill Modifier:	Damage = $(16 + [1D16 \times \text{skill}])$ hit points
Expert Result:	Recovery time = Average
Master Result:	Recovery time = Average
Restrictions:	Undead only

**Spell 6: Day of the Gods**

Description:	Simultaneously casts Power, Meditation, Speed, Lucky Day, Precision, and Guardian Angel on all your characters for one easy payment. The duration of this spell is one day.
Casting Cost:	45
Recovery Time:	Very Slow
Damage Result:	None
Target:	Party
Base Spell/Skill Modifier:	Cast all six spells at $(\text{skill} \times 2)$
Expert Result:	Cast all six spells at $(\text{skill} \times 3)$
Master Result:	Cast all six spells at $(\text{skill} \times 4)$
Restrictions:	Not cumulative

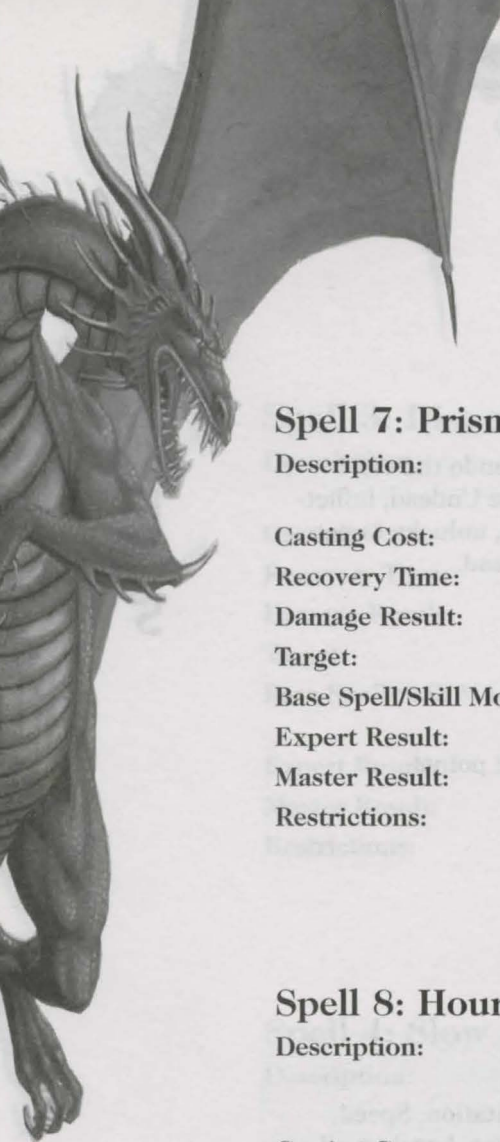

Spell 7: Prismatic Light

Description:	Inflicts moderate damage on all creatures in sight. This spell can only be cast indoors.
Casting Cost:	50
Recovery Time:	Slow
Damage Result:	Magic
Target:	All enemies within view
Base Spell/Skill Modifier:	Damage = (25 + skill) hit points
Expert Result:	Recovery time = Slow
Master Result:	Recovery time = Slow
Restrictions:	Indoors



Spell 8: Hour of Power

Description:	Simultaneously casts Haste, Heroism, Shield, Stone Skin, and Bless on all your characters. The duration of the Hour of Power is, of course, one hour.
Casting Cost:	55
Recovery Time:	Very Slow
Damage Result:	None
Target:	Party
Base Spell/Skill Modifier:	Cast all five spells at (skill × 2)
Expert Result:	Cast all five spells at (skill × 3)
Master Result:	Cast all five spells at (skill × 4)
Restrictions:	Not cumulative



Spell 9: Paralyze



Description:	Temporarily prevents a monster from moving or attacking for the (short) duration of this spell. Attack your helpless target to your heart's content; Paralyzed monsters can't retaliate.
Casting Cost:	60
Recovery Time:	Slow
Damage Result:	Magic
Target:	One enemy
Base Spell/Skill Modifier:	Duration = (skill × 1) minutes
Expert Result:	Recovery time = Slow
Master Result:	Recovery time = Slow
Restrictions:	None

Spell 10: Sunray



Description:	The game's second most devastating spell, Sunray concentrates the light of the sun on one unfortunate creature. Because Sunray must focus sunlight, it works only outdoors and during the day.
Casting Cost:	65
Recovery Time:	Very Slow
Damage Result:	Fire
Target:	One enemy
Base Spell/Skill Modifier:	Damage = (20 + [1D20 × skill]) hit points
Expert Result:	Recovery time = Slow
Master Result:	Recovery time = Slow
Restrictions:	Outdoors + daytime

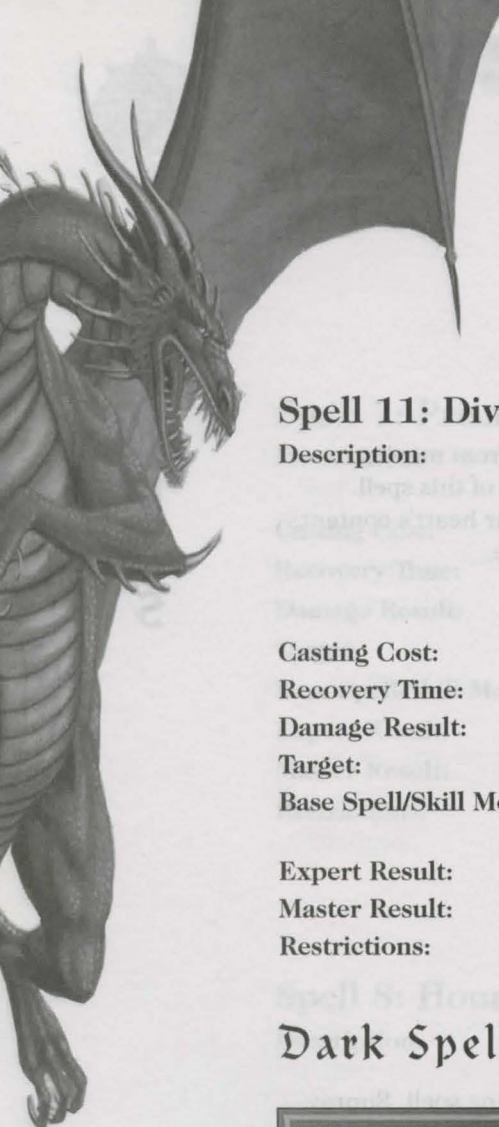

Spell 11: Divine Intervention

Description:	Once per day during the rising or setting of the sun you may call upon Heaven to heal your characters of all damage, restore your spell points, and remove all adverse conditions. The gods exact a price, however, aging the caster 10 years for each casting of Divine Intervention.
Casting Cost:	70
Recovery Time:	Very Slow
Damage Result:	None
Target:	Party
Base Spell/Skill Modifier:	Cure Party, (recovery time - [skill × 5]), can cast once per day
Expert Result:	Can cast twice per day
Master Result:	Can cast thrice per day
Restrictions:	Dawn or dusk only

Dark Spells





Spell 1: Reanimate

- Description:** Allows you to raise a lifeless creature from the dead (sort of). The spell doesn't make them grateful or peaceful in any way, but you can always kill them again, if you want.
- Casting Cost:** 20
- Recovery Time:** Average
- Damage Result:** None
- Target:** One enemy
- Base Spell/Skill Modifier:** Reset enemy/no treasure/target recovers (10 × skill) hit points
- Expert Result:** Target recovers (20 × skill) hit points
- Master Result:** Target recovers (30 × skill) hit points
- Restrictions:** None



Spell 2: Toxic Cloud

- Description:** A poisonous cloud of noxious gasses forms in front of the caster and moves slowly away from your characters. The cloud does a moderate amount of damage and lasts until something runs into it.
- Casting Cost:** 30
- Recovery Time:** Slow
- Damage Result:** Poison
- Target:** Forward
- Base Spell/Skill Modifier:** Damage = (25 + [1D10 × skill]) hit points
- Expert Result:** Recovery time = Average
- Master Result:** Recovery time = Average
- Restrictions:** None

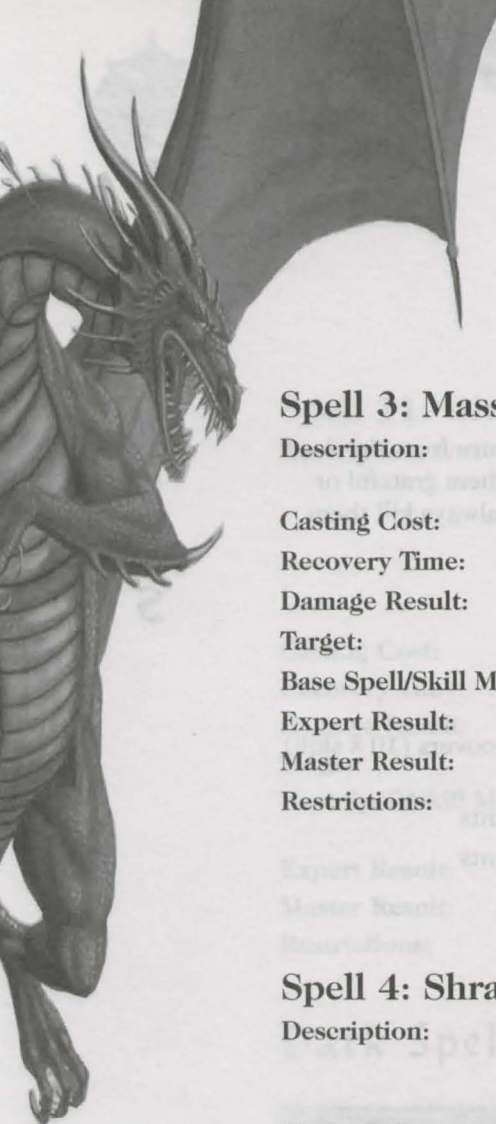

Spell 3: Mass Curse

Description:	Inflicts the cursed condition on all monsters in sight of the caster.
Casting Cost:	40
Recovery Time:	Slow
Damage Result:	Magic
Target:	All enemies within view
Base Spell/Skill Modifier:	Duration = (skill × 1) minutes
Expert Result:	Duration = (skill × 2) minutes
Master Result:	Duration = (skill × 4) minutes
Restrictions:	None



Spell 4: Shrapmetal

Description:	Fires a blast of hot, jagged metal in front of the caster, striking any creature that gets in the way and inflicting moderate damage.
Casting Cost:	50
Recovery Time:	Average
Damage Result:	Physical
Target:	Forward, with multiple missiles
Base Spell/Skill Modifier:	Damage = (6 + [1D6 × skill]) hit points, three shots
Expert Result:	Recovery time = Fast, five shots
Master Result:	Recovery time = Fast, seven shots
Restrictions:	None



Spell 5: Shrinking Ray

- Description:** Shrinks even the grandest of monsters to more manageable sizes. Apprentices will reduce a creature to at least half its normal size, while Experts and Masters will reduce a creature to one-third and one-fourth their size, respectively. A shrunken monster deals only one-half, one-third, or one-fourth normal damage when it attacks.
- Casting Cost:** 60
- Recovery Time:** Slow
- Damage Result:** Magic
- Target:** One enemy
- Base Spell/Skill Modifier:** Duration = (skill × 5) minutes, one-half size
- Expert Result:** One-third size
- Master Result:** One-quarter size
- Restrictions:** None



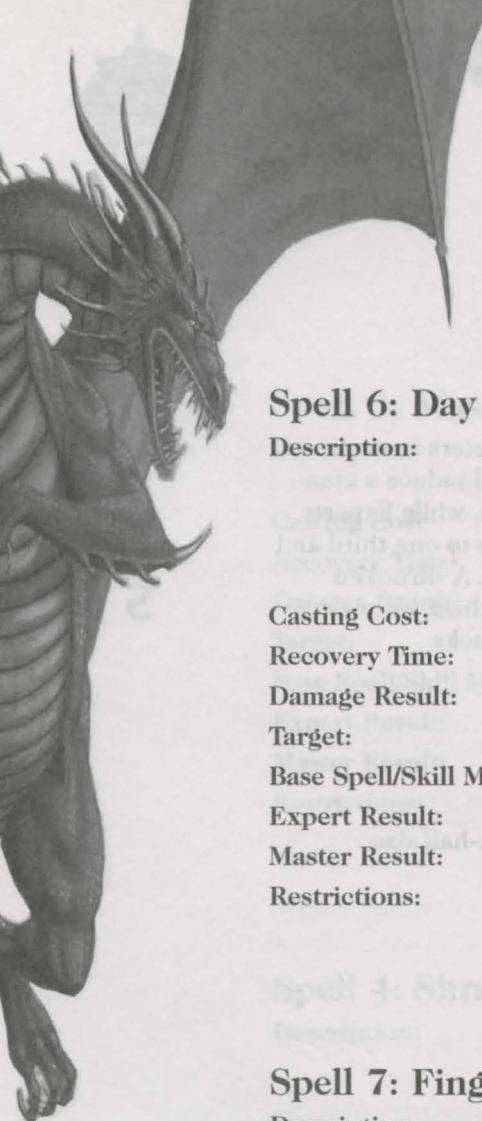

Spell 6: Day of Protection

Description:	Casts Protection from Fire, Protection from Electricity, Protection from Cold, Protection from Poison, Protection from Magic, Feather Fall, and Wizard Eye simultaneously on the entire party. The spell lasts for one day.
Casting Cost:	70
Recovery Time:	Very Slow
Damage Result:	None
Target:	Party
Base Spell/Skill Modifier:	Casts all seven spells at (skill \times 2)
Expert Result:	Casts all seven spells at (skill \times 3)
Master Result:	Casts all seven spells at (skill \times 4)
Restrictions:	Not cumulative



Spell 7: Finger of Death

Description:	Attempts to slay a single creature immediately by stripping its soul from its body. Finger of Death has a 3 percent chance per skill point in Dark magic of working, with Experts and Masters getting 4 percent and 5 percent chances per skill point, respectively.
Casting Cost:	80
Recovery Time:	Slow
Damage Result:	Magic
Target:	One enemy
Base Spell/Skill Modifier:	Success rat = (skill \times 3%)
Expert Result:	Success rate = (skill \times 4%)
Master Result:	Success rate = (skill \times 5%)
Restrictions:	None

**Spell 8: Moon Ray****Description:**

A powerful spell of Darkness, Moon Ray heals your characters and damages all monsters in sight. It doesn't do a lot of damage or cure a condition, but it's the only spell that harms all monsters in sight and works outside. Moon Ray is restricted to working outdoors and in the *moonlight*: The New Moon isn't good enough!

Casting Cost:

90

Recovery Time:

Slow

Damage Result:

Magic

Target:

All enemies within view + party

Base Spell/Skill Modifier:

Heal and damage = (1D4 × skill) hit points

Expert Result:

Recovery time = Slow

Master Result:

Recovery time = Slow

Restrictions:

Outdoors + moonlight

**Spell 9: Dragon Breath****Description:**

Empowers the caster to exhale a cloud of toxic vapors that targets a single monster and damages all creatures nearby. This spell is the game's most powerful damage spell.

Casting Cost:

100

Recovery Time:

Slow

Damage Result:

Poison

Target:

One enemy + radius

Base Spell/Skill Modifier:

Damage = (1D25 × skill) hit points, 512-unit radius

Expert Result:

Recovery time = Slow

Master Result:

Recovery time = Slow

Restrictions:

None



Spell 10: Armageddon

Description:

This spell is the town killer. It can be cast only once per day by Apprentices to Dark magic, and only outdoors at that. Armageddon inflicts 50 points of damage plus one point of damage for every point of Dark skill your character has to every creature on the map, including the party. Experts can cast Armageddon twice per day, and Masters can cast this spell three times per day.

Casting Cost:

150

Recovery Time:

Very Slow

Damage Result:

Magic

Target:

All

Base Spell/Skill Modifier:

Damage = (50 + skill) hit points to all in map, can be cast once per day

Expert Result:

Can be cast twice per day

Master Result:

Can be cast thrice per day

Restrictions:

Outdoors



Spell 11: Dark Containment

Description:	This spell attempts to trap the force of darkness into its victims, hence the name Dark Containment. The target of the spell will suffer from random effects—though certain creatures are immune to this spell.
Casting Cost:	200
Recovery Time:	Very Slow
Damage Result:	Magic
Target:	Forward
Base Spell/Skill Modifier:	Unknown
Expert Result:	Unknown
Master Result:	Unknown
Restrictions:	None





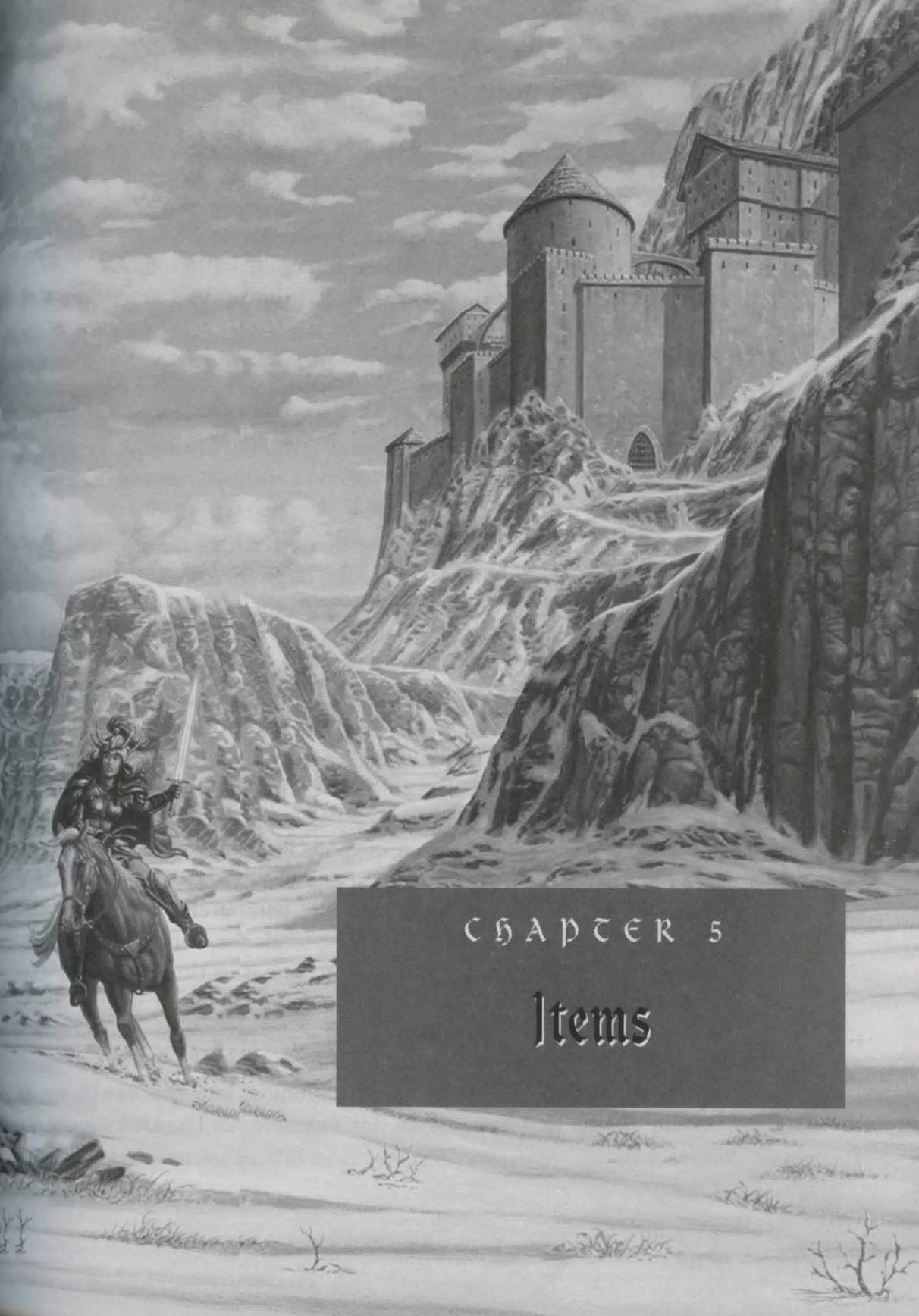

CHAPTER 5

Items



The number of items you can pick up and carry around in *Might and Magic VI* is, um, large. Items range from letters and scrolls to weapons and gems. As with the other lists, you'll need a bit of explanation to comprehend it all.

Value is the cost of the item if you bought it from a merchant. You won't get this amount of money from selling the item, even if you're a master Merchant. Quest items have no value (you can't buy or sell them). Skill Group is the skill you must have to equip the item. If no skill group is listed, then anyone can equip the item or it can't be equipped at all.

The Damage statistic in the weapons list tells you how much damage the weapon can do. For instance, a Warrior Sword can do $3d3+3$ damage; that is, when it connects, the computer rolls three three-sided dice, and then adds three to the total. Yes, three-sided dice are a logical impossibility, but you can imagine it as three six-sided dice, with each die divided by two and rounded up. Thus, a Warrior Sword can do 6 to 12 points of damage. Even if the weapon is unidentified, it will still do the amount of damage appropriate for its identified status.

Bodily protection items (armor, shields, and the like) have an Armor Bonus that appears as, for example, $2+16$. This means the



item has a base armor modifier of two, with an additional, magically imbued, modifier of 16. Should the item break while you're wearing it (not uncommon), its Armor Bonus reverts to its base armor modifier. If it carries no "plus" modifier, the item reverts to a "0 armor" item. If neither a Damage modifier nor an Armor Bonus modifier is listed, the item has no such modifications.

Identify/Repair Skill is the base amount of skill points you need to identify or repair the item. If you have a base skill of 2 in the Identify Item skill, you can identify a Longsword easily, but identifying a Warrior Sword will be beyond you. Repairing an item works likewise, using the Repair Item skill. Note that repairing a broken magical item, such as a wand, won't restore charges to the item, but repairing a magically endowed item, such as a Longsword of Might +3, will restore that item's magical characteristics.

The Not Identified Name of an item is the name you see when you right-click the item in your inventory. The description of an unidentified item matches the description for the Not Identified Name of the item. So, for instance, if you're carrying around a Lionheart Sword you haven't identified, its description will read, "Longsword: Of simple make and design, this longsword is deadly nonetheless."

WEAPONS

Longsword

Value:	50
Skill Group:	Sword
Damage:	3d3
Identify/Repair Skill:	1
Not Identified Name:	Longsword

Of simple make and design, this longsword is deadly nonetheless.



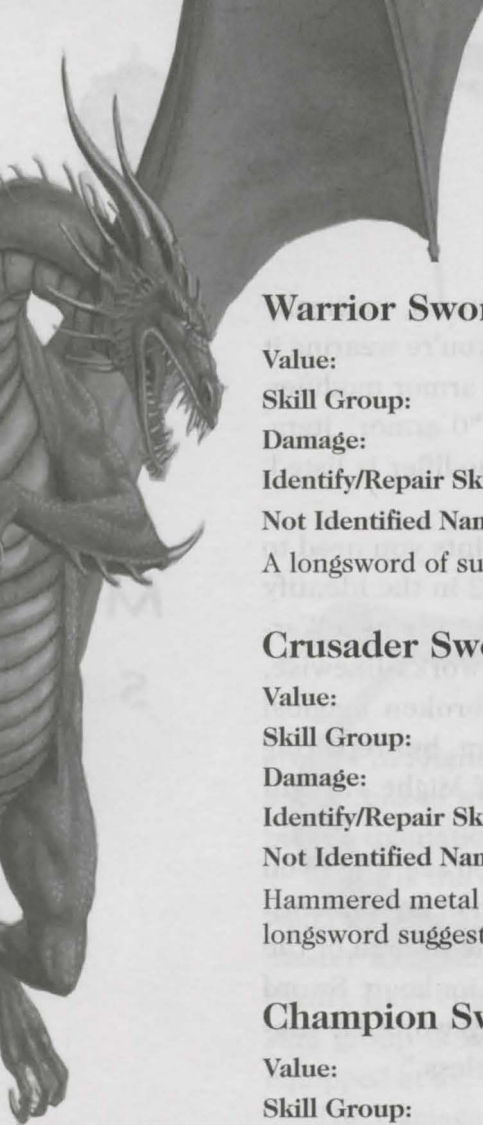

Warrior Sword

Value: 200
Skill Group: Sword
Damage: 3d3+3
Identify/Repair Skill: 3
Not Identified Name: Longsword

A longsword of superior strength and edge.



Crusader Sword

Value: 350
Skill Group: Sword
Damage: 3d3+6
Identify/Repair Skill: 5
Not Identified Name: Longsword

Hammered metal patterns on the blade of this longsword suggest high quality Dwarven manufacture.

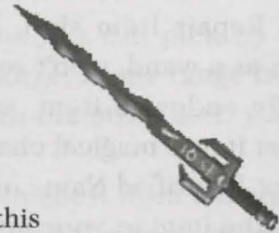

Champion Sword

Value: 500
Skill Group: Sword
Damage: 3d3+9
Identify/Repair Skill: 7
Not Identified Name: Longsword

An extremely high quality longsword, this weapon is one of no more than 1,000 of its kind forged by master weaponsmith Mekorig the Blind (circa 780–800).

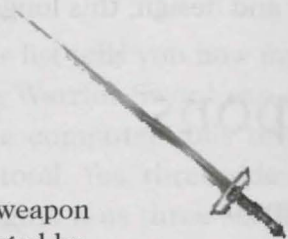

Lionheart Sword

Value: 650
Skill Group: Sword
Damage: 3d3+12
Identify/Repair Skill: 9
Not Identified Name: Longsword

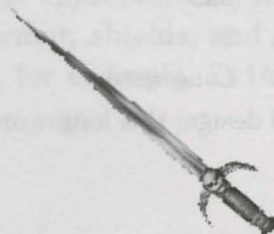



A weapon as rare as it is ancient, this longsword was forged during the Time of Wonders. The process used to forge steel of this quality was lost sometime just after the Silence.

Two-Handed Sword

Value: 400
Skill Group: Sword
Damage: 4d5
Identify/Repair Skill: 1

Not Identified Name: Two-Handed Sword

A basic two-handed sword. Thousands of these low-quality weapons can be found throughout Enroth.

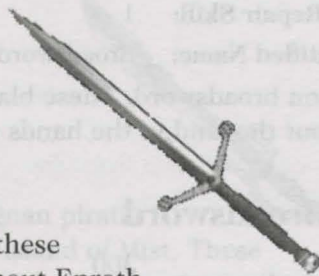

Great Sword

Value: 500
Skill Group: Sword
Damage: 4d5+2
Identify/Repair Skill: 6

Not Identified Name: Two-Handed Sword

Yet another simple two-handed sword, this barbarian's weapon sports a wavy blade and an extra crosspiece. Its construction is sturdy and the blade is sharp.

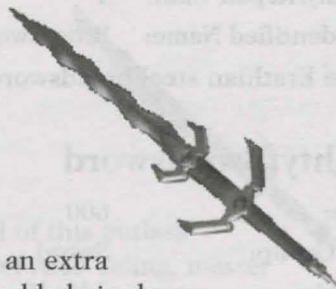

Heroic Sword

Value: 800
Skill Group: Sword
Damage: 4d5+8
Identify/Repair Skill: 8

Not Identified Name: Two-Handed Sword

An unusually high-quality two-handed sword, this blade is both strong and reliable.

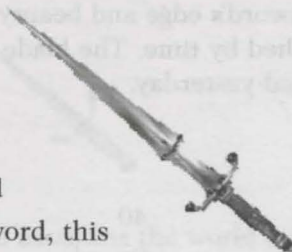

Broadsword

Value:	100
Skill Group:	Sword
Damage:	3d4
Identify/Repair Skill:	1
Not Identified Name:	Broadsword

A common broadsword. These blades can be found throughout the land in the hands of both heroes and villains.

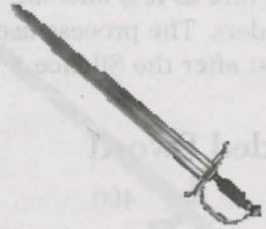

Steel Broadsword

Value:	300
Skill Group:	Sword
Damage:	3d4+4
Identify/Repair Skill:	4
Not Identified Name:	Broadsword

A fine Erathian steel broadsword of excellent quality and edge.



Mighty Broadsword

Value:	600
Skill Group:	Sword
Damage:	3d4+10
Identify/Repair Skill:	6
Not Identified Name:	Broadsword

This broadsword's edge and beauty are enchanted and untouched by time. The blade looks as though it were forged yesterday.



Cutlass

Value:	40
Skill Group:	Sword
Damage:	2d4
Identify/Repair Skill:	1





Not Identified Name: Cutlass

A cutlass of Goblin manufacture, this blade is as deadly as it is ugly.

Pirate Cutlass

Value: 290

Skill Group: Sword

Damage: 2d4+5

Identify/Repair Skill: 3

Not Identified Name: Cutlass

The traditional backup weapon of the Regnan pirates living on the countless islands east of the island of Mist. These cutlasses were forged by one of a long line of smiths native to those islands.



Master Cutlass

Value: 590

Skill Group: Sword

Damage: 2d4+11

Identify/Repair Skill: 5

Not Identified Name: Cutlass

Cleverly concealed initials near the pommel of this cutlass prove this beautiful weapon to be the work of Alec Teling, master smith to Hareck IX, Lord of Regna, and emperor of the Endless Ocean.

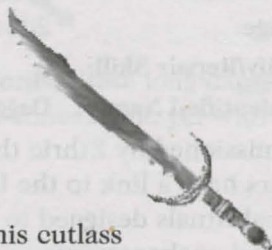

Dagger

Value: 8

Skill Group: Dagger

Damage: 2d2

Identify/Repair Skill: 1

Not Identified Name: Dagger

A common dagger, favorite of thieves and assassins the world over.



Blood Dagger

Value:	100
Skill Group:	Dagger
Damage:	2d2+2
Identify/Repair Skill:	2
Not Identified Name:	Dagger



Blood Daggers are ceremonial weapons worn by the nobility of Regna. Their popularity has spread in recent years to the nobility of Enroth, and now they can be found throughout the land. Though ceremonial, they're sharp and reliable blades.

Shadow Dagger

Value:	150
Skill Group:	Dagger
Damage:	2d2+3
Identify/Repair Skill:	3
Not Identified Name:	Dagger



Commissioned by Ethric the Mad while still a human, it is said these daggers have a link to the Land of the Dead. They are used in certain magical rituals designed to extend life to unnatural lengths, and can hold powerful enchantments.

Mage Dagger

Value:	250
Skill Group:	Dagger
Damage:	2d2+5
Identify/Repair Skill:	4
Not Identified Name:	Dagger



One of less than a hundred such blades, Mage Daggers were carried and forged by members of the Alchemical Alliance roughly 300 years ago in the fires beneath Castle Alamos. It's no longer possible to make a finer blade than a Mage Dagger.



Jeweled Dagger

Value:	300
Skill Group:	Dagger
Damage:	2d2+6
Identify/Repair Skill:	5
Not Identified Name:	Dagger



A weapon from the Time of Wonders, this blade is of extreme age and quality.

Long Dagger

Value:	15
Skill Group:	Dagger
Damage:	2d3
Identify/Repair Skill:	1
Not Identified Name:	Long Dagger



This is the common long dagger. Bordering on swords, these long daggers are favored by assassins who want a weapon both concealable yet with a longer reach than the traditional dagger.

Piercing Dagger

Value:	200
Skill Group:	Dagger
Damage:	2d3+4
Identify/Repair Skill:	3
Not Identified Name:	Long Dagger

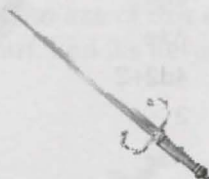

Really more of a short sword than a dagger, the narrow blade belies an unusual strength and a possibly enchanted edge.

Divine Dagger

Value:	350
Skill Group:	Dagger
Damage:	2d3+7
Identify/Repair Skill:	5
Not Identified Name:	Long Dagger



A "Weapon of the Gods," this weapon was one of the last created before the great forges fell to the Silence in the year 113 A.S. (After the Silence).

Hand Axe

Value:	30
Skill Group:	Axe
Damage:	4d2
Identify/Repair Skill:	1
Not Identified Name:	Axe



More of a tool than a weapon, this simple axe will work in a pinch. But don't expect much.

Battle Axe

Value:	100
Skill Group:	Axe
Damage:	4d2+2
Identify/Repair Skill:	2
Not Identified Name:	Axe



Made as a weapon of war instead of a tool, the battle axe is usually employed by barbarians and undisciplined armies.

War Axe

Value:	250
Skill Group:	Axe
Damage:	4d2+5
Identify/Repair Skill:	4
Not Identified Name:	Axe





This War Axe appears to be one of a large shipment of such axes seized by Roland during the Succession War. It was manufactured in Karigor by order of Archibald Ironfist to be used against his brother in their struggle for the throne of Enroth.

Dwarven Axe

Value: 400
 Skill Group: Axe
 Damage: 4d2+8
 Identify/Repair Skill: 5
 Not Identified Name: Axe



An example of the high-quality work done by the Dwarves of the Red Mountains, the blade is sharp and the balance perfect.

Supreme Axe

Value: 550
 Skill Group: Axe
 Damage: 4d2+11
 Identify/Repair Skill: 6
 Not Identified Name: Axe

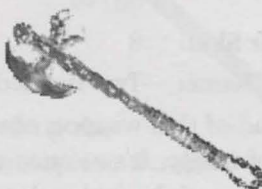

This weapon surely has a dark history. An axe of this quality is only forged as the personal weapon of a noble Dwarf, and it's never sold or traded away.

Poleax

Value: 300
 Skill Group: Axe
 Damage: 3d7
 Identify/Repair Skill: 1
 Not Identified Name: Two-Handed Axe



This style of long-hafted axe is typically used to deadly effect by Eastern tribes and the elite guard of some members of the nobility.

Heavy Poleax

Value:	450
Skill Group:	Axe
Damage:	3d7+3
Identify/Repair Skill:	5
Not Identified Name:	Two-Handed Axe

A stronger version of the basic Poleax, this weapon is frequently used by city guards and other fighters who don't expect to do battle in large, coordinated groups (such as armies).

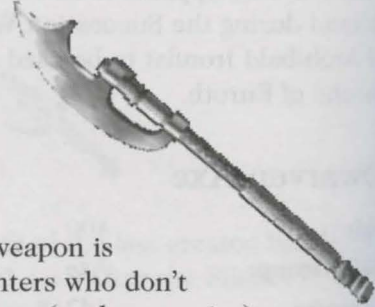

Grand Poleax

Value:	750
Skill Group:	Axe
Damage:	3d7+9
Identify/Repair Skill:	8
Not Identified Name:	Two-Handed Axe

The blade head of this weapon obviously was created with the aid of magic. It's at once unusually sharp and light.



Spear

Value:	15
Skill Group:	Spear
Damage:	1d9
Identify/Repair Skill:	1
Not Identified Name:	Spear

Barely more than a sharpened stick, this spear is still quite deadly. Like all spears, it can be used in one or both hands.

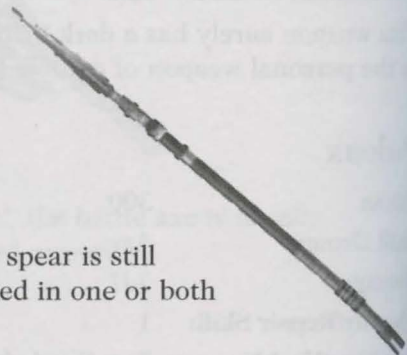



Stout Spear

Value:	50
Skill Group:	Spear
Damage:	1d9+1
Identify/Repair Skill:	2
Not Identified Name:	Spear

This spear has a reinforced steel tip to help it penetrate tough armor and hides. Like all spears, it can be used in one or both hands.

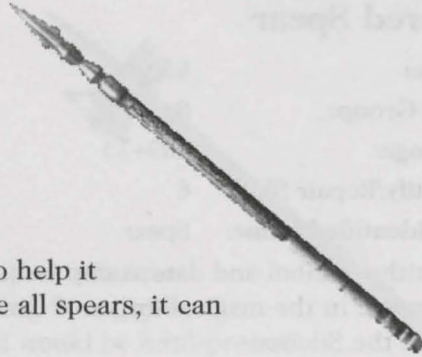

Serpent Spear

Value:	250
Skill Group:	Spear
Damage:	1d9+5
Identify/Repair Skill:	3
Not Identified Name:	Spear

Decorated with carved serpents running along the shaft, this spear comes equipped with a crosspiece designed to prevent impaled foes from sliding along the shaft of the spear and striking a blow at you as they die. Like all spears, it can be used in one or both hands.

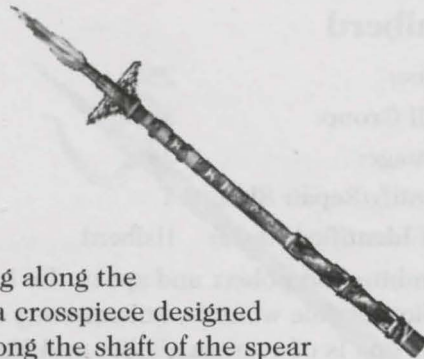

Savage Spear

Value:	450
Skill Group:	Spear
Damage:	1d9+9
Identify/Repair Skill:	4
Not Identified Name:	Spear

Composed entirely of a rare, bluish metal, the lower half of this spear is wrapped in expensive leather. A collector's item! Like all spears, it can be used in one or both hands.

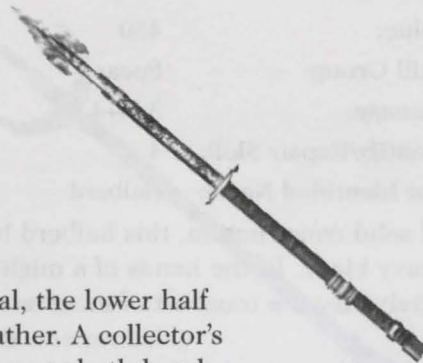

Sacred Spear

Value:	650
Skill Group:	Spear
Damage:	1d9+13
Identify/Repair Skill:	6
Not Identified Name:	Spear

A smithy symbol and date stamp indicate this spear was made in the magical forges of Governor Padish 12 years before the Silence.

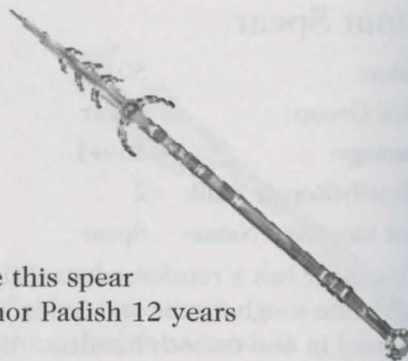

Halberd

Value:	250
Skill Group:	Spear
Damage:	3d6
Identify/Repair Skill:	1
Not Identified Name:	Halberd

Combination poleax and spear, the halberd can inflict terrible wounds, but recovers slowly from swings. This one is of average quality and workmanship.

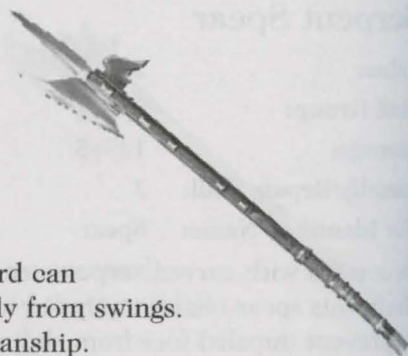

Massive Halberd

Value:	450
Skill Group:	Spear
Damage:	3d6+4
Identify/Repair Skill:	4
Not Identified Name:	Halberd

Of solid construction, this halberd has a particularly heavy blade. In the hands of a mighty warrior, it could surely slay the toughest of monsters.

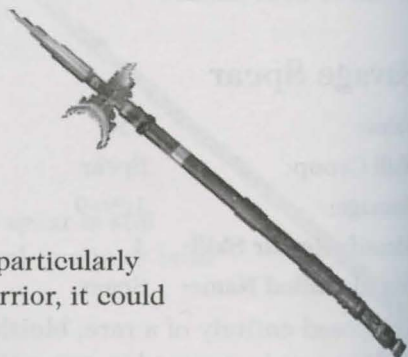



Elite Halberd

Value: 750
 Skill Group: Spear
 Damage: 3d6+10
 Identify/Repair Skill: 8
 Not Identified Name: Halberd

A small stamp on the blade of this weapon indicates it was constructed in the famous Mekorig Foundry by the master himself, Mekorig the Blind. You would be hard-pressed to find a finer halberd anywhere in the world.

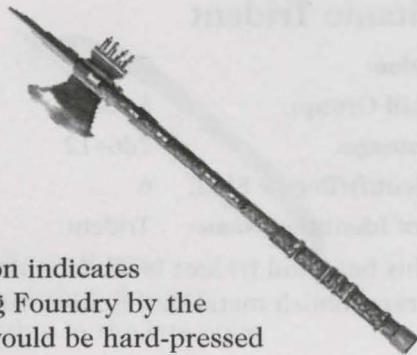

Trident

Value: 100
 Skill Group: Spear
 Damage: 2d6
 Identify/Repair Skill: 1
 Not Identified Name: Trident

Common war tridents, like this one, are good-quality weapons issued by the Imperial Regnan Navy to facilitate the collection of Imperial tariffs on the high seas. (Most merchants and other governments refer to this activity as piracy.)

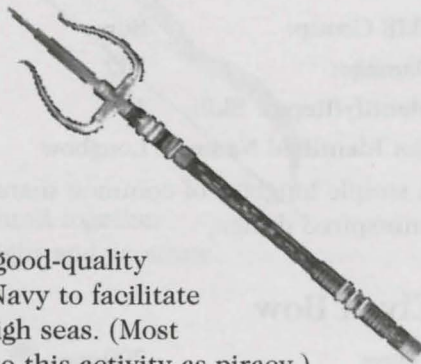

Ornate Trident

Value: 400
 Skill Group: Spear
 Damage: 2d6+6
 Identify/Repair Skill: 3
 Not Identified Name: Trident

A high-quality war trident of the style given to officers of the Imperial Regnan Navy. This one probably was taken from an officer during an Imperial taxation battle that went poorly for the navy.

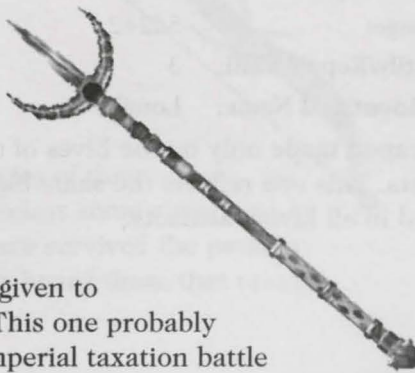

Titanic Trident

Value:	700
Skill Group:	Spear
Damage:	2d6+12
Identify/Repair Skill:	6
Not Identified Name:	Trident

This beautiful trident is made mostly of Kergar, a rare, bluish metal that neither rusts nor lose its edge.

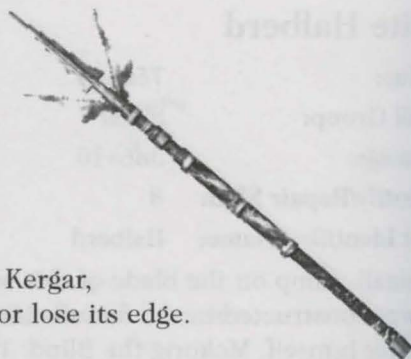

Longbow

Value:	100
Skill Group:	Bow
Damage:	5d2
Identify/Repair Skill:	1
Not Identified Name:	Longbow

A simple longbow of common materials and uninspired design.

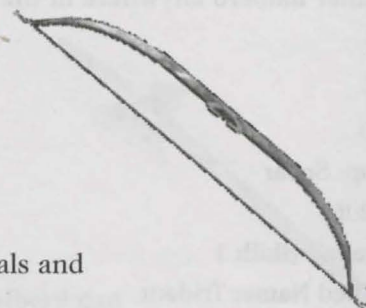

Elven Bow

Value:	200
Skill Group:	Bow
Damage:	5d2+2
Identify/Repair Skill:	3
Not Identified Name:	Longbow

A weapon made only by the Elves of the great Erathian forests. This one reflects the same high-quality workmanship found in all Elvish artifacts.

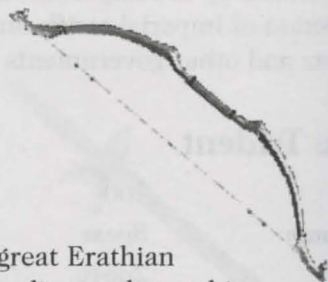



Precision Bow

Value: 300
 Skill Group: Bow
 Damage: 5d2+4
 Identify/Repair Skill: 5
 Not Identified Name: Longbow

Etched initials at the base of the bow indicate it was made by master bowyer Ivan Selving's workshop during the Timber Wars against the Elves of Erathia in the late 600s.

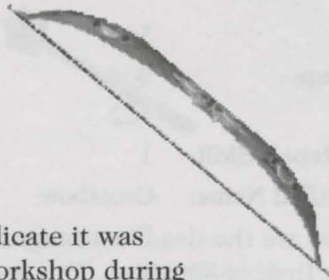

Magic Bow

Value: 400
 Skill Group: Bow
 Damage: 5d2+6
 Identify/Repair Skill: 7
 Not Identified Name: Longbow

This bow comprises strange materials bound together by subtle enchantments. It's extremely light and accurate.

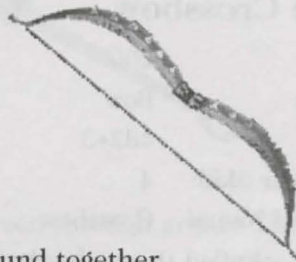

Stellar Bow

Value: 500
 Skill Group: Bow
 Damage: 5d2+8
 Identify/Repair Skill: 9
 Not Identified Name: Longbow

Created by stripping the Heavenly Forges of their enchanted parts when they became useless some years after the Silence, few of these bows have survived the passage of time. Elves and individual collectors hoard those that remain.

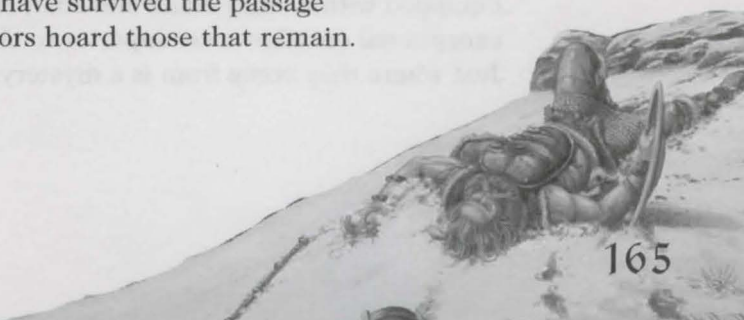
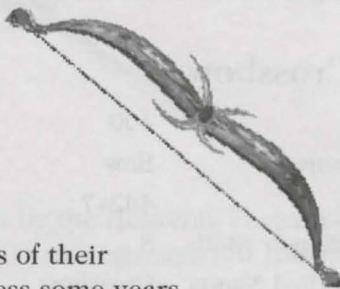

Crossbow

Value:	50
Skill Group:	Bow
Damage:	4d2
Identify/Repair Skill:	1
Not Identified Name:	Crossbow



Crossbows are the deadliest ranged weapons made since the Time of Wonders. This crossbow is made of stout yew wood and metal fixtures, but is otherwise ordinary.

Accurate Crossbow

Value:	200
Skill Group:	Bow
Damage:	4d2+3
Identify/Repair Skill:	4
Not Identified Name:	Crossbow



Archibald stockpiled these crossbows to use against his brother just prior to the Succession War. As with most decisions involving death, Archibald chose wisely. These crossbows are among the best in the land.

True Crossbow

Value:	400
Skill Group:	Bow
Damage:	4d2+7
Identify/Repair Skill:	8
Not Identified Name:	Crossbow

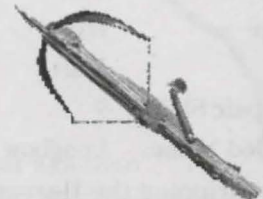

Equipped with a hand crank and shaft sights, these exceptional crossbows are superior to all that came before. Just where they come from is a mystery.

**Mace**

Value: 50
 Skill Group: Mace
 Damage: 2d4
 Identify/Repair Skill: 1
 Not Identified Name: Mace



Little more than a glorified club, this common mace is made of ordinary materials and unexceptional craftsmanship.

Wicked Mace

Value: 150
 Skill Group: Mace
 Damage: 2d4+2
 Identify/Repair Skill: 2
 Not Identified Name: Mace



Solidly designed to inflict fatal injuries, even through armor. The balance is a little top-heavy, but the craftsmanship is good.

Thunder Mace

Value: 300
 Skill Group: Mace
 Damage: 2d4+5
 Identify/Repair Skill: 3
 Not Identified Name: Mace



This mace is one of thousands turned out by the Heavenly Forges before the Silence. But that was more than 1,000 years ago, and few remain.

Wonder Mace

Value:	450
Skill Group:	Mace
Damage:	2d4+8
Identify/Repair Skill:	4
Not Identified Name:	Mace

Only magic could make such an ungainly weapon so light and yet hit with such force.

**Death Mace**

Value:	600
Skill Group:	Mace
Damage:	2d4+11
Identify/Repair Skill:	6
Not Identified Name:	Mace

Constructed by the Necromancer's Guild just prior to their fall during the Succession War, these unusual weapons are almost always enchanted with powerful magics.

**Hammer**

Value:	120
Skill Group:	Mace
Damage:	2d5
Identify/Repair Skill:	1
Not Identified Name:	Hammer

A graceless and unimaginative weapon, hammers are slow, but hit very hard. This one is of common construction and materials.

**Dark Hammer**

Value:	300
Skill Group:	Mace
Damage:	2d5+3





Identify/Repair Skill: 3
Not Identified Name: Hammer

A step up in construction quality, these hammers are commonly wielded by humanoid monsters. Everyone knows most monsters don't make weapons, so the question arises, from where are they getting them?

Holy Hammer

Value: 600
Skill Group: Mace
Damage: 2d5+9
Identify/Repair Skill: 5
Not Identified Name: Hammer



Magically constructed, these hammers are the property of the Church of the Moon in Karigor.

Club

Value: 1
Skill Group: Club
Damage: 1d3
Identify/Repair Skill: 0
Not Identified Name: Club



A primitive weapon usable by even the stupidest of monsters. You're not thinking of using this, are you?

Spiked Club

Value: 40
Skill Group: Club
Damage: 1d3+3
Identify/Repair Skill: 2
Not Identified Name: Club

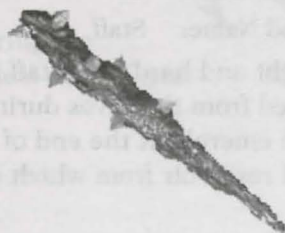

An improvement over the simple club, this spiked club will inflict nastier wounds.

Killer Club

Value:	100
Skill Group:	Club
Damage:	1d3+5
Identify/Repair Skill:	3
Not Identified Name:	Club



King of the club family. If this weapon had a knob or ball on the end, it would be a mace. Real craftsmanship is evident in this club, but no true identifying marks indicating who created it are visible.

Staff

Value:	40
Skill Group:	Staff
Damage:	2d4
Identify/Repair Skill:	1
Not Identified Name:	Staff

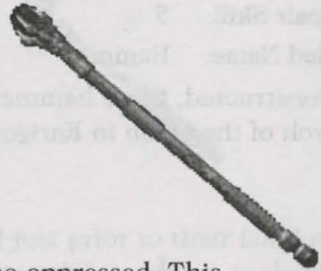

The staff is the traditional weapon of the oppressed. This one is unremarkable; the "ruby" at the end is just colored glass.

Emerald Staff

Value:	200
Skill Group:	Staff
Damage:	2d4+3
Identify/Repair Skill:	4
Not Identified Name:	Staff

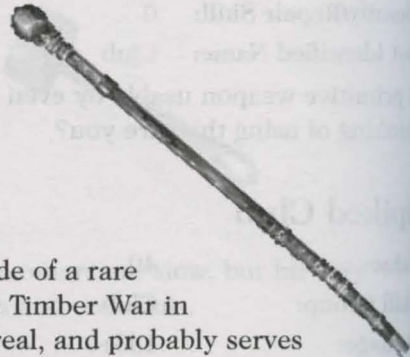

Magically light and hard, this staff is made of a rare wood stripped from the Elves during the Timber War in 600 A.S. The emerald at the end of it is real, and probably serves as a magical reservoir from which the staff draws its strength.



Power Staff

Value:	400
Skill Group:	Staff
Damage:	2d4+7
Identify/Repair Skill:	6
Not Identified Name:	Staff

This staff, with others of its kind, was found in the treasure room of the Necromancer's Guild after their disastrous defeat by Roland at the end of the Succession War.

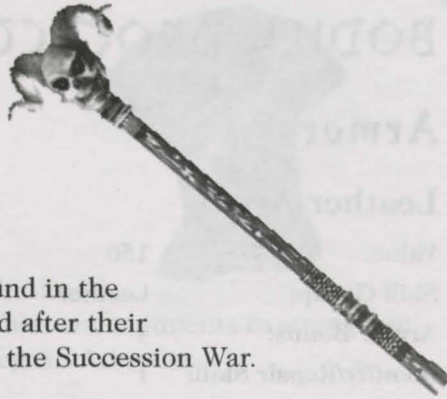

Blaster

Value:	0
Skill Group:	Blaster
Damage:	3d5+8
Identify/Repair Skill:	20
Not Identified Name:	Strange Device

A weapon of awesome power, clearly created during the Time of Wonders.



Blaster Rifle

Value:	0
Skill Group:	Blaster
Damage:	4d5+12
Identify/Repair Skill:	20
Not Identified Name:	Strange Device

The finest of personal weapons made during the Time of Wonders, this Blaster Rifle can deal death faster than any weapon you have ever seen.

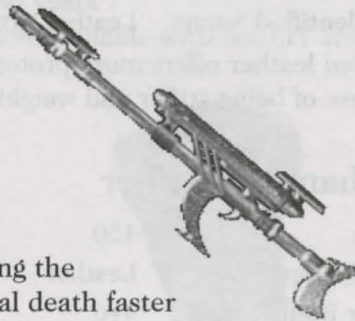

BODILY PROTECTION

Armor

Leather Armor

Value:	150
Skill Group:	Leather
Armor Bonus:	4
Identify/Repair Skill:	1
Not Identified Name:	Leather Armor



Easiest to make and lightest of the armors, leather armor offers the least protection. This particular suit is of average quality.

Studded Leather

Value:	250
Skill Group:	Leather
Armor Bonus:	4+2
Identify/Repair Skill:	3
Not Identified Name:	Leather Armor



Studded leather offers more protection than regular leather armor at the expense of being stiffer and weighing more. This particular suit is well-made.

Enchanted Leather

Value:	450
Skill Group:	Leather
Armor Bonus:	4+6
Identify/Repair Skill:	5
Not Identified Name:	Leather Armor



An otherwise ordinary suit of leather armor, this suit is imbued with a subtle enchantment that strengthens the material against blows without increasing weight.



Dragon Leather

Value:	750
Skill Group:	Leather
Armor Bonus:	4+12
Identify/Repair Skill:	7
Not Identified Name:	Leather Armor



Standard issue leather armor for officers in the Regnan Navy. All such leather armor receives enchantments to strengthen and lighten it during its creation in the Regnan Armories.

Imperial Leather

Value:	1150
Skill Group:	Leather
Armor Bonus:	4+20
Identify/Repair Skill:	9
Not Identified Name:	Leather Armor



An extremely rare suit of leather armor created during the conflicts between the Church of the Moon and the Church of the Sun roughly 80 years ago. These suits provide the finest protection available with leather armor.

Chain Mail

Value:	400
Skill Group:	Chain
Armor Bonus:	8
Identify/Repair Skill:	1
Not Identified Name:	Chain Mail



Chain mail is an armor formed of small, interlocking loops of metal. This suit is low quality: The metal used is plain iron, there are only two layers of rings, and it's heavy and stiff for its size.

Steel Chain Mail

Value:	600
Skill Group:	Chain
Armor Bonus:	8+4
Identify/Repair Skill:	4
Not Identified Name:	Chain Mail

A superior suit of chain mail, the metal used in this suit is steel, and the former owner was careful to keep the suit well-oiled and free of rust.



Noble Chain Mail

Value:	900
Skill Group:	Chain
Armor Bonus:	8+10
Identify/Repair Skill:	6
Not Identified Name:	Chain Mail

Cavalry officer's chain mail from the reign of Taledon V of Karigor, Divine High Priest and High Holy Conduit of the Church of the Sun, circa 870 A.S. The armor is high-quality chain, enchanted to lighten and strengthen the metal.



Royal Chain Mail

Value:	1300
Skill Group:	Chain
Armor Bonus:	8+18
Identify/Repair Skill:	8
Not Identified Name:	Chain Mail

Highly enchanted armor worn by Elvish nobility and royalty during the Timber Wars of the seventh and eighth centuries.





Majestic Chain Mail

Value:	1800
Skill Group:	Chain
Armor Bonus:	8+28
Identify/Repair Skill:	10
Not Identified Name:	Chain Mail



A very rare suit of armor turned out by the Heavenly Forges of Governor Padish before the Silence. The armor originally was worn strictly by the governor and his highest military officers as a badge of office. It's not just for show; this chain mail is lighter, stronger, and suppler than any other chain in the world.

Plate Mail

Value:	1000
Skill Group:	Plate
Armor Bonus:	20
Identify/Repair Skill:	1
Not Identified Name:	Plate Mail



Composed of interlocking plates and joints, plate mail is the best unenchanted armor available. It is, however, heavy and slows the movements of the wearer. This particular suit is of average quality and the smith is unknown.

Steel Plate Mail

Value:	1300
Skill Group:	Plate
Armor Bonus:	20+6
Identify/Repair Skill:	6
Not Identified Name:	Plate Mail

Well-constructed plates of steel work together to form an overall excellent suit of armor. A foundry stamp under the right arm indicates it was forged recently in Kelebrim.



Golden Plate Mail

Value:	2700
Skill Group:	Plate
Armor Bonus:	20+34
Identify/Repair Skill:	12
Not Identified Name:	Plate Mail

This suit of plate mail was forged in the Mekorig foundry 18 years after the death of Mekorig the Blind. A masterwork, the armor is almost as easy to wear as ordinary clothes, and is probably the best armor available in the world.





Shields

Kite Shield

Value:	200
Skill Group:	Shield
Armor Bonus:	6
Identify/Repair Skill:	1
Not Identified Name:	Large Shield



Formed of stretched hides over a wooden frame, this simple shield provides basic protection against physical attacks.

Tower Shield

Value:	300
Skill Group:	Shield
Armor Bonus:	6+1
Identify/Repair Skill:	3
Not Identified Name:	Large Shield



The simplicity of the heraldic design on this shield leads one to believe it was created either by barbarians or goblins. It's made of sturdy materials and should stand up reasonably well in combat.

Castle Shield

Value:	400
Skill Group:	Shield
Armor Bonus:	6+3
Identify/Repair Skill:	5
Not Identified Name:	Large Shield



This shield is made of iron-framed wood. It's somewhat heavy for its size, but it should see you through a battle safely—as long as you're not backstabbed.

Celestial Shield

Value:	500
Skill Group:	Shield
Armor Bonus:	6+7
Identify/Repair Skill:	7
Not Identified Name:	Large Shield

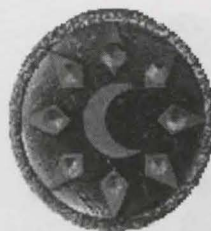

Made of a lightweight metal, this shield has a foundry stamp from the Kelebrim armory. Though light, the material is very strong, and the metal is welded almost seamlessly.

Olympian Shield

Value:	800
Skill Group:	Shield
Armor Bonus:	6+13
Identify/Repair Skill:	9
Not Identified Name:	Large Shield



These shields were forged in the Phynaxian Empire during its brief rise to power on the steppes of southern Erathia (790–864). They're made of stalt, a metal that takes well to enchantment, and contributed heavily to Phynaxian military might. Unfortunately, very little of the metal could be mined, and Phynaxia fell in 864 A.S. to an Elvish offensive.

Wooden Shield

Value:	100
Skill Group:	Shield
Armor Bonus:	4
Identify/Repair Skill:	1
Not Identified Name:	Small Shield



A small wooden shield designed to protect mostly against arrows.



Bronze Shield

Value:	200
Skill Group:	Shield
Armor Bonus:	4+2
Identify/Repair Skill:	2
Not Identified Name:	Small Shield



Bronze shields are lighter than steel shields of the same size, but aren't nearly as strong.

Steel Shield

Value:	300
Skill Group:	Shield
Armor Bonus:	4+4
Identify/Repair Skill:	3
Not Identified Name:	Small Shield



Because this shield is made of tempered steel, it should resist all but the most unusual enchanted weapons.

Spirit Shield

Value:	450
Skill Group:	Shield
Armor Bonus:	4+8
Identify/Repair Skill:	4
Not Identified Name:	Small Shield



Spirit shields are ordinary steel shields enchanted using a ritual that can have powerful, albeit unpredictable, results. The process is time-consuming and requires the undivided attention of at least three masters of Spirit magic.

Astral Shield

Value:	750
Skill Group:	Shield
Armor Bonus:	4+14
Identify/Repair Skill:	5
Not Identified Name:	Small Shield



These rare shields were turned out by the hundreds with the aid of the Heavenly Forges to combat rebel forces in the endless string of skirmishes and supply raids that tested (and finally overcame) the governor's forces in the first century A.S. As with all such equipment, it's light, tough, and can hold the most powerful enchantments.

Helms

Helm

Value:	60
Armor Bonus:	2
Identify/Repair Skill:	1
Not Identified Name:	Helm



An ordinary helm made of hides stretched over wood. There's no fur or padding on the inside, so your head probably will ring like a bell when struck a solid blow.

Steel Helm

Value:	260
Armor Bonus:	2+4
Identify/Repair Skill:	4
Not Identified Name:	Helm



This is a common steel helm. The design is a good one and has been used for centuries by warriors all around the world. Best guess is this helm is 50 to 75 years old.



Guardian Helm

Value: 360
 Armor Bonus: 2+6
 Identify/Repair Skill: 6
 Not Identified Name: Helm



This helm design has been used by the Elves of Erathia since before the Silence. It's composed of silver and steel and is very strong.

Defender Helm

Value: 460
 Armor Bonus: 2+8
 Identify/Repair Skill: 8
 Not Identified Name: Helm



Half made from the skull of the ferocious Mogred beast in Karigor, these helms grow more uncommon every year as the Mogreds approach extinction. The red stripes around the horns of the helm are highly receptive to enchantment.

Angelic Helm

Value: 560
 Armor Bonus: 2+10
 Identify/Repair Skill: 10
 Not Identified Name: Helm



These helms are extremely rare and no one knows where they originate, but they almost certainly come from the Time of Wonders. An extremely fine inscription inside the helm says "property of ship's store, VARN MCMIV."

Cloaks

Leather Cloak

Value:	50
Armor Bonus:	1
Identify/Repair Skill:	2
Not Identified Name:	Cloak



A used leather cloak. It smells faintly of mothballs and dust.

Phantom Cloak

Value:	150
Armor Bonus:	1+2
Identify/Repair Skill:	3
Not Identified Name:	Cloak



Indigo dye from the Regnan Archipelago was used to stain this wool cloak the color of a summer night's sky.

Elven Cloak

Value:	250
Armor Bonus:	1+4
Identify/Repair Skill:	4
Not Identified Name:	Cloak



Woven from plant fibers found in the forests of Erathia, these cloaks are the traditional garb of the Elven Rangers.

Cardinal Cloak

Value:	450
Armor Bonus:	1+6
Identify/Repair Skill:	5
Not Identified Name:	Cloak



A cloak formerly worn by high officials of the Church of the Sun of Karigor prior to its dissolution in 1083 A.S. Nearly all these cloaks were enchanted in one way or another.



Doom's Day Cloak

Value: 750

Armor Bonus: 1+8

Identify/Repair Skill: 6

Not Identified Name: Cloak



Worn by high officials of the Church of the Moon of Karigor before it was dissolved in 1083 A.S., most of these cloaks have enchantments upon them.

Gauntlets

Gauntlets

Value: 100

Armor Bonus: 3

Identify/Repair Skill: 2

Not Identified Name: Gauntlets



A steel-plated gauntlet of simple make and design.

Knight Gauntlets

Value: 250

Armor Bonus: 3+3

Identify/Repair Skill: 4

Not Identified Name: Gauntlets



This gauntlet is an improvement over the simple, inflexible steel gauntlets commonly worn by goblins and brigands. The back of the hand and wrist are solid, while the jointing around the fingers is made of chain links to improve dexterity.

Paladin Gauntlets

Value:	450
Armor Bonus:	3+5
Identify/Repair Skill:	6
Not Identified Name:	Gauntlets



Although lacking in flexibility, this gauntlet has reinforced joints over the knuckles and at the base of the wrist.

Cavalier Gauntlets

Value:	650
Armor Bonus:	3+7
Identify/Repair Skill:	8
Not Identified Name:	Gauntlets



A high-quality gauntlet, it offers both flexibility and protection. The joints are reinforced, yet are "soft" enough to permit nearly normal hand motion.

Ultimate Gauntlets

Value:	850
Armor Bonus:	3+9
Identify/Repair Skill:	10
Not Identified Name:	Gauntlets



Dwarven smiths created this masterpiece of gauntlet design. Except for the extra bulk, there seems little difference between this gauntlet and a velvet glove. Clever sliding and rotating plates at the joints and wrist permit full normal hand motion while providing continuous protection at all times.



Boots

Leather Boots

Value:	50
Armor Bonus:	2
Identify/Repair Skill:	3
Not Identified Name:	Boots



Common traveler's boots made with leather and hobnailed.

Steel Boots

Value:	250
Armor Bonus:	2+4
Identify/Repair Skill:	4
Not Identified Name:	Boots



Heavy steel boots made for solid foot protection in battle. They're uncomfortable to walk in and have a tendency to rust on the inside.

Armored Boots

Value:	450
Armor Bonus:	2+6
Identify/Repair Skill:	5
Not Identified Name:	Boots



The interior of these steel-plated boots is made of leather and cloth to soften the sharp edges on the metal plates. They're a bit heavy and exhausting to wear for extended periods.

Sterling Boots

Value: 650
 Armor Bonus: 2+8
 Identify/Repair Skill: 6
 Not Identified Name: Boots



Polished silver boots with velvet interiors, these boots are lighter than steel boots and far more comfortable. They look pretty snappy, too.

Ultimate Boots

Value: 850
 Armor Bonus: 2+10
 Identify/Repair Skill: 7
 Not Identified Name: Boots



Dragonhide boots reinforced with molded horn strips and stalt metal rivets. Soft and light, they provide unparalleled foot protection.

Headgear

Cloth Hat

Value: 20
 Identify/Repair Skill: 1
 Not Identified Name: Hat



A common hat. The material is a blend of cotton and wool, and the feather is from a duck.

Fancy Hat

Value: 100
 Identify/Repair Skill: 2
 Not Identified Name: Hat



Fashionable and stylish, these hats are in vogue among the upper classes and those seeking to emulate them.



Wizard Cap

Value: 200

Identify/Repair Skill: 3

Not Identified Name: Hat



Don't laugh. Although silly—even ridiculous—in appearance, many sorcerers spend quite a bit of time enchanting hats like this with powerful magics. The conical shape and “eyes” in the front of the hat are peculiarly attractive to creatures of the spirit world, and that property makes the hat easier to enchant.

Crown

Value: 250

Identify/Repair Skill: 12

Not Identified Name: Crown



This is a poorly wrought crown, the kind that Goblins or low-budget actors might create to mock royalty. It offers no real head protection, although it may carry some small enchantment.

Regal Crown

Value: 450

Identify/Repair Skill: 14

Not Identified Name: Crown



A large, imperfect sapphire is set in the center of this delicate silver crown. Extremely fine hammer marks suggest this crown was made by Dwarven hands.

Almighty Crown

Value: 650

Identify/Repair Skill: 16

Not Identified Name: Crown



Crowns of this sort typically are created using magic to enhance their susceptibility to magic. If found with no enchantments whatsoever, the crown probably was left unfinished for some reason.

Belts

Leather Belt

Value: 40
 Identify/Repair Skill: 1
 Not Identified Name: Belt

A common strip of leather used to hold up your pants.



Mercenary Belt

Value: 100
 Identify/Repair Skill: 2
 Not Identified Name: Belt

A wide leather belt with a big, flashy buckle of a kind favored by bandits and mercenaries. Both mercenaries and bandits like to have charms or minor enchantments placed on them as battle aids.



Vanguard Belt

Value: 225
 Identify/Repair Skill: 3
 Not Identified Name: Belt

Cured dragonhide and polished bronze are fastened together to form a belt of unusual strength and resistance to magic. Although difficult to work with, these belts can offer excellent protection against magic once an enchantment is successfully laid upon them.



Warlord Belt

Value: 450
 Identify/Repair Skill: 4
 Not Identified Name: Belt

Made of silver and the hide of some unknown creature, this belt is studded with vertical strips of a golden alloy. The buckle is a single, large opal set in a platinum base.





Sovereign Belt

Value: 600

Identify/Repair Skill: 5

Not Identified Name: Belt



Though soft and flexible, the material of this belt is made of extremely fine strands of white gold. The white gold is braided by a process too exacting for human hands, and the ruby set into the buckle was perfectly cut by a process long lost in time.

Jewelry

Fine Ring

Value: 100

Identify/Repair Skill: 2

Not Identified Name: Ring



A small golden ring with a quarter-carat diamond. The style is simple and elegant.

Sparkling Ring

Value: 300

Identify/Repair Skill: 4

Not Identified Name: Ring



Two amethysts adorn this plain platinum ring.

Lunar Ring

Value: 500

Identify/Repair Skill: 6

Not Identified Name: Ring



A gold ring with a large moonstone set in the center. These rings typically carry an enchantment.

Witch Ring

Value: 700

Identify/Repair Skill: 8

Not Identified Name: Ring

Rings such as this one were worn by the Witches' Guild to signify membership during their heyday (550–800 A.S.).

**Blessed Ring**

Value: 900

Identify/Repair Skill: 10

Not Identified Name: Ring

Three gems, symmetrically equal in size and quality, adorn a hammered gold band. The center gem is a ruby, and the two flanking gems are purple topazes.

**Valuable Ring**

Value: 1100

Identify/Repair Skill: 12

Not Identified Name: Ring

A large star sapphire flanked by two smaller rubies decorate an otherwise plain gold band.

**Precious Ring**

Value: 1300

Identify/Repair Skill: 14

Not Identified Name: Ring

The three pearls mounted on a gold base glimmer a faint blue when held in the sunlight, offering insight as to the source of their magic.





Ethereal Ring

Value: 1500
 Identify/Repair Skill: 16
 Not Identified Name: Ring



A hammered white gold ring with a large central diamond and two small pearls. Light doesn't fall upon it normally. The ring glitters and fades unpredictably, as though it were lit by an invisible sun shining in an unseen parallel world.

Exquisite Ring

Value: 1700
 Identify/Repair Skill: 18
 Not Identified Name: Ring



Three opals rimmed with a strange red metal are set in a perfect ring of stalt—a very rare metal found only in southern Erathia.

Scarab Ring

Value: 2000
 Identify/Repair Skill: 20
 Not Identified Name: Ring



A gold band adorned with the shell of a rare beetle found only in the deserts of Enroth. Treated properly by an alchemist, these shells can be made to hold the mightiest of enchantments.

Turquoise Amulet

Value: 500
 Identify/Repair Skill: 2
 Not Identified Name: Amulet



A turquoise stone bracketed by a bronze chain and clasp makes for an inexpensive, yet charming amulet.



Gothic Amulet

Value: 750
Identify/Repair Skill: 4
Not Identified Name: Amulet

This bizarre amulet probably was created by some alchemist with a distorted understanding of magic. The shape and symmetry help maintain whatever enchantment he put in it.



Claw Amulet

Value: 1000
Identify/Repair Skill: 6
Not Identified Name: Amulet

The ossified foot of some unknown beast or monster has been set with a huge, imperfect purple topaz. It's not pretty, but it's certainly magical.



Ancient Amulet

Value: 1250
Identify/Repair Skill: 8
Not Identified Name: Amulet

This amulet comprises two pieces: The front piece is an ancient, perfectly cut rectangle of a strong, stainless metal. The backing is a much more recent gold chain and clasp. Careful inspection of the front piece reveals it to be a plaque displaying the name of some long-dead soldier or worker. Symbols on the front probably indicate status and rank.



Ruby Star Amulet

Value: 1500
Identify/Repair Skill: 10
Not Identified Name: Amulet

A perfect ruby cut in a star shape and bracketed by a golden clasp give this amulet its name. When viewed in dim light, a fiery spark can be seen dancing in the center of the gem.





WANDS

Standard Wands

All standard wands carry the following description:

"A rod of blue metal and wood capped with a blue headstone."

All require an Identify Item skill of 5 to identify successfully.

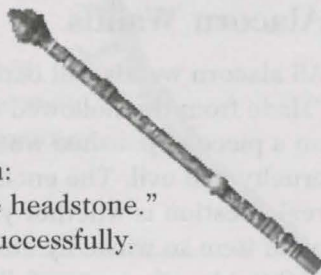

NAME	VALUE
Wand of Flame	1,000
Wand of Static	1,000
Wand of Cold	1,000
Wand of Stunning	1,000
Wand of Arrows	1,000

Fairy Wands

All fairy wands will carry the following

description: "More a staff than a wand, this

fairy wand is inexplicably alive, even though it

was cut from its parent tree many years ago."

All require an Identify Item skill of 7 to identify successfully.

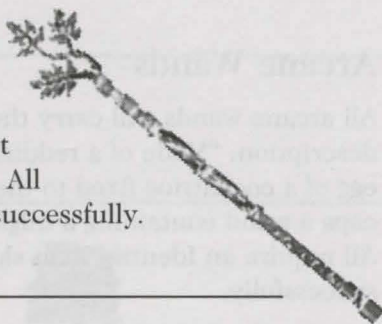

NAME	VALUE
Fairy Wand of Fire	1,500
Fairy Wand of Sparks	1,500
Fairy Wand of Poison	1,500
Fairy Wand of Mind	1,500
Fairy Wand of Harm	1,500

Alacorn Wands

All alacorn wands will carry the following description: "Made from the hollowed out horn of a unicorn and spitted on a piece of polished wood, wands like these are born of cruelty and evil. The enchantment it holds is useful; the only real question is whether you believe your cause justifies the use of an item so wickedly created." All require an Identify Item skill of 9 to identify successfully.

NAME	VALUE
Alacorn Wand of Fireballs	2,000
Alacorn Wand of Ice	2,000
Alacorn Wand of Swarms	2,000
Alacorn Wand of Blades	2,000
Alacorn Wand of Charms	2,000

Arcane Wands

All arcane wands will carry the following description: "Made of a reddish metal, the egg of a cockatrice fixed to the business end caps a wand containing a mighty enchantment." All require an Identify Item skill of 11 to identify successfully.

NAME	VALUE
Arcane Wand of Blasting	2,500
Arcane Wand of Lightning	2,500
Arcane Wand of Rocks	2,500
Arcane Wand of Paralyzing	2,500
Arcane Wand of Clouds	2,500



Mystic Wands

All mystic wands will carry the following description: "Formed of the clawed forepaw of a baby dragon, wands like this one can hold the strongest of spells." All require an Identify Item skill of 13 to identify successfully.

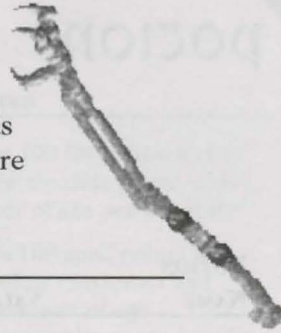

NAME	VALUE
Mystic Wand of Implosion	3,000
Mystic Wand of Distortion	3,000
Mystic Wand of Shrapmetal	3,000
Mystic Wand of Shrinking	3,000
Mystic Wand of Death	3,000

HERBS

NAME	VALUE
Poppysnaps	2
Phirna Root	3
Widoweeps Berries	4



POPPYSNAPS



PHIRNA ROOT



WIDOWEEPS
BERRIES

POTIONS



POTION NAME	VALUE	ID SKILL	NOT IDENTIFIED NAME	NOTES
Cure Wounds	10	1	Red Potion	Restores 10 hit points
Magic Potion	10	1	Blue Potion	Restores 10 spell points
Energy	10	1	Yellow Potion	Adds 10 to primary statistics temporarily
Protection	25	2	Orange Potion	Adds 10 to armor class temporarily
Resistance	25	2	Green Potion	Adds 10 to all resistances temporarily
Cure Poison	25	2	Purple Potion	Cures Poison
Supreme Protection	50	3	White Potion	Adds 20 to armor class temporarily
Restoration	50	3	White Potion	Cures all conditions except dead or stoned
Extreme Energy	50	3	White Potion	Adds 20 to primary statistics temporarily
Super Resistance	50	3	White Potion	Adds 20 to resistances temporarily
Heroism	50	3	White Potion	Grants Heroism (as the spell) for 6 hours
Haste	50	3	White Potion	Grants Haste (as the spell) for 6 hours
Stone Skin	50	3	White Potion	Grants Stone Skin (as the spell) for 6 hours
Bless	50	3	White Potion	Grants Bless (as the spell) for 6 hours
Divine Power	100	5	Black Potion	Adds 20 to level temporarily and adds 1 year of age permanently

CHAPTER 5 Items



I T E M S

POTION NAME	VALUE	ID SKILL	NOT IDENTIFIED NAME	NOTES
Divine Cure	100	5	Black Potion	Adds 100 hit points if at or below maximum and adds 1 year of age permanently
Divine Magic	100	5	Black Potion	Adds 100 spell points if at or below maximum and adds 1 year of age permanently
Essence of Might	100	5	Black Potion	Once only: Adds 15 to Might and subtracts 5 from Intellect permanently
Essence of Intellect	100	5	Black Potion	Once only: Adds 15 to Intellect and subtracts 5 from Might permanently
Essence of Personality	100	5	Black Potion	Once only: Adds 15 to Personality and subtracts 5 from Speed permanently
Essence of Endurance	100	5	Black Potion	Once only: Adds 15 to Endurance and subtracts 1 from all other statistics permanently
Essence of Accuracy	100	5	Black Potion	Once only: Adds 15 to Accuracy and subtracts 5 from Luck permanently
Essence of Speed	100	5	Black Potion	Once only: Adds 15 to Speed and subtracts 5 from Personality permanently
Essence of Luck	100	5	Black Potion	Once only: Adds 15 to Luck and subtracts 5 from Accuracy permanently
Rejuvenation	100	5	Black Potion	Removes all magical aging effects and subtracts 1 from all 7 primary statistics

SCROLLS



NAME	VALUE	ID SKILL
Torch Light	10	1
Flame Arrow	20	1
Protection from Fire	30	2
Fire Bolt	40	2
Haste	50	3
Fireball	75	3
Ring of Fire	100	4
Fire Blast	150	4
Meteor Shower	200	5
Inferno	300	5
Incinerate	500	5
Wizard Eye	10	1
Static Charge	20	1
Protection from Electricity	30	2
Sparks	40	2
Feather Fall	50	3
Shield	75	3
Lightning Bolt	100	4
Jump	150	4
Implosion	200	5
Fly	300	5
Starburst	500	5
Awaken	10	1
Cold Beam	20	1
Protection from Cold	30	2
Poison Spray	40	2
Water Walk	50	3

CHAPTER 5 Items



I T E M S

NAME	VALUE	ID	SKILL
Ice Bolt	75	3	
Enchant Item	100	4	
Acid Burst	150	4	
Town Portal	200	5	
Ice Blast	300	5	
Lloyd's Beacon	500	5	
Stun	10	1	
Magic Arrow	20	1	
Protection from Magic	30	2	
Deadly Swarm	40	2	
Stone Skin	50	3	
Blades	75	3	
Stone to Flesh	100	4	
Rock Blast	150	4	
Turn to Stone	200	5	
Death Blossom	300	5	
Mass Distortion	500	5	
Spirit Arrow	10	1	
Bless	20	1	
Healing Touch	30	2	
Lucky Day	40	2	
Remove Curse	50	3	
Guardian Angel	75	3	
Heroism	100	4	
Turn Undead	150	4	
Raise Dead	200	5	
Shared Life	300	5	
Resurrection	500	5	
Meditation	10	1	
Remove Fear	20	1	
Mind Blast	30	2	
Precision	40	2	
Cure Paralysis	50	3	
Charm	75	3	
Mass Fear	100	4	
Feeblemind	150	4	

MIGHT & MAGIC VI: The Mandate of Heaven

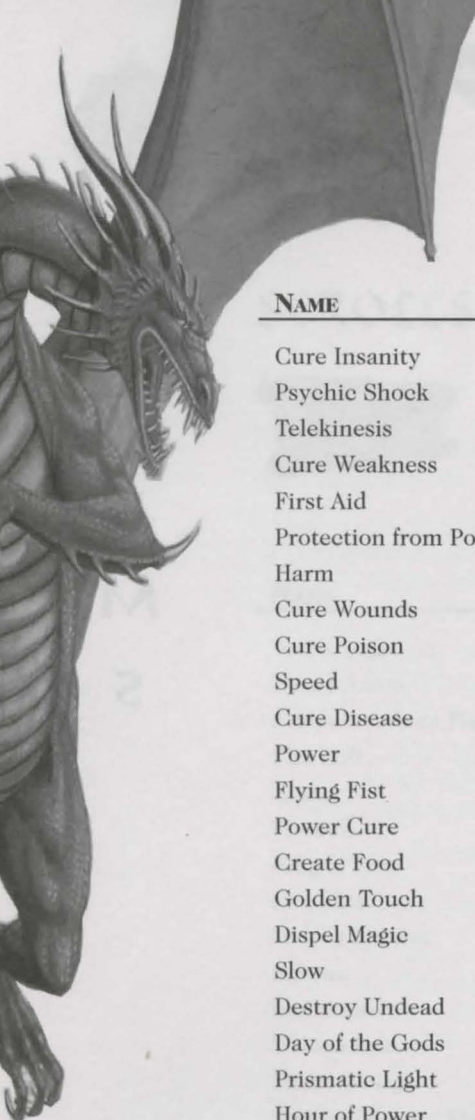

NAME	VALUE	ID SKILL
Cure Insanity	200	5
Psychic Shock	300	5
Telekinesis	500	5
Cure Weakness	10	1
First Aid	20	1
Protection from Poison	30	2
Harm	40	2
Cure Wounds	50	3
Cure Poison	75	3
Speed	100	4
Cure Disease	150	4
Power	200	5
Flying Fist	300	5
Power Cure	500	5
Create Food	100	1
Golden Touch	150	1
Dispel Magic	200	2
Slow	250	2
Destroy Undead	300	3
Day of the Gods	350	3
Prismatic Light	400	4
Hour of Power	500	4
Paralyze	600	5
Sun Ray	750	5
Divine Intervention	1,000	5
Reanimate	100	1
Toxic Cloud	150	1
Mass Curse	200	2
Shrapmetal	250	2
Shrinking Ray	300	3
Day of Protection	350	3
Finger of Death	400	4
Moon Ray	500	4
Dragon Breath	600	5
Armageddon	750	5



SPELLBOOKS



NAME	VALUE	ID SKILL
Torch Light	100	1
Flame Arrow	200	1
Protection from Fire	300	2
Fire Bolt	400	2
Haste	500	3
Fireball	750	3
Ring of Fire	1,000	4
Fire Blast	1,500	4
Meteor Shower	2,000	5
Inferno	3,000	5
Incinerate	5,000	5
Wizard Eye	100	1
Static Charge	200	1
Protection from Electricity	300	2
Sparks	400	2
Feather Fall	500	3
Shield	750	3
Lightning Bolt	1,000	4
Jump	1,500	4
Implosion	2,000	5
Fly	3,000	5
Starburst	5,000	5



MIGHT & MAGIC VI: The Mandate of Heaven

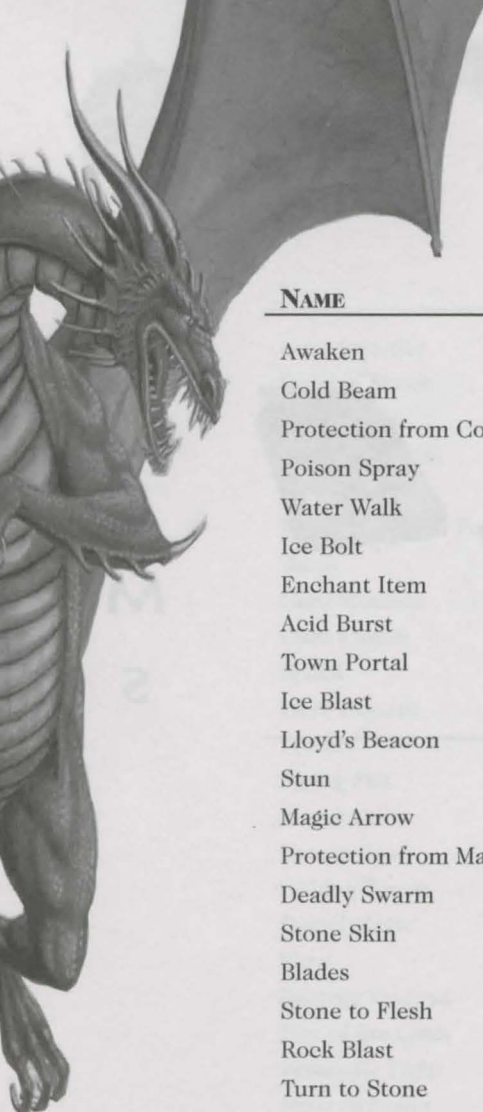

NAME	VALUE	ID SKILL
Awaken	100	1
Cold Beam	200	1
Protection from Cold	300	2
Poison Spray	400	2
Water Walk	500	3
Ice Bolt	750	3
Enchant Item	1,000	4
Acid Burst	1,500	4
Town Portal	2,000	5
Ice Blast	3,000	5
Lloyd's Beacon	5,000	5
Stun	100	1
Magic Arrow	200	1
Protection from Magic	300	2
Deadly Swarm	400	2
Stone Skin	500	3
Blades	750	3
Stone to Flesh	1,000	4
Rock Blast	1,500	4
Turn to Stone	2,000	5
Death Blossom	3,000	5
Mass Distortion	5,000	5
Spirit Arrow	100	1
Bless	200	1
Healing Touch	300	2
Lucky Day	400	2
Remove Curse	500	3
Guardian Angel	750	3
Heroism	1,000	4
Turn Undead	1,500	4
Raise Dead	2,000	5
Shared Life	3,000	5
Resurrection	5,000	5

CHAPTER 5 Items



I T E M S

NAME	VALUE	ID	SKILL
Meditation	100	1	
Remove Fear	200	1	
Mind Blast	300	2	
Precision	400	2	
Cure Paralysis	500	3	
Charm	750	3	
Mass Fear	1,000	4	
Feeblemind	1,500	4	
Cure Insanity	2,000	5	
Psychic Shock	3,000	5	
Telekinesis	5,000	5	
Cure Weakness	100	1	
First Aid	200	1	
Protection from Poison	300	2	
Harm	400	2	
Cure Wounds	500	3	
Cure Poison	750	3	
Speed	1,000	4	
Cure Disease	1,500	4	
Power	2,000	5	
Flying Fist	3,000	5	
Power Cure	5,000	5	
Create Food	1,000	1	
Golden Touch	1,500	1	
Dispel Magic	2,000	2	
Slow	2,500	2	
Destroy Undead	3,000	3	
Day of the Gods	3,500	3	
Prismatic Light	4,000	4	
Hour of Power	5,000	4	
Paralyze	6,000	5	
Sun Ray	7,500	5	
Divine Intervention	10,000	5	



NAME	VALUE	ID SKILL
Reanimate	1,000	1
Toxic Cloud	1,500	1
Mass Curse	2,000	2
Shrapmetal	2,500	2
Shrinking Ray	3,000	3
Day of Protection	3,500	3
Finger of Death	4,000	4
Moon Ray	5,000	4
Dragon Breath	6,000	5
Armageddon	7,500	5

ARTIFACTS

Weapons

Mordred

Value:	20,000
Skill Group:	Dagger
Damage:	2d3+8
Identify/Repair Skill:	15
Not Identified Name:	Artifact

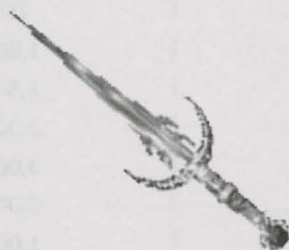

One of nine such blades in the world, Mordred was made by the Brotherhood in 428 A.S. as part of their first experiments in the development of Dark Magic. Their hope was to find a way to extend one person's life at the expense of another's, but they merely found a way to steal health.

**Thor**

Value: 20,000
 Skill Group: Mace
 Damage: 2d5+12
 Identify/Repair Skill: 15
 Not Identified Name: Artifact



The origins of Thor are lost in time, but this mighty barbarian weapon is well remembered by military historians. The weapon has been used in battles by many owners for centuries, although its last appearance was at the battle of Shimengard in 902 A.S. The force of a blow from this hammer is so powerful it can knock foes several feet back away from the wielder.

Conan

Value: 20,000
 Skill Group: Axe
 Damage: 3d7+10
 Identify/Repair Skill: 15
 Not Identified Name: Artifact

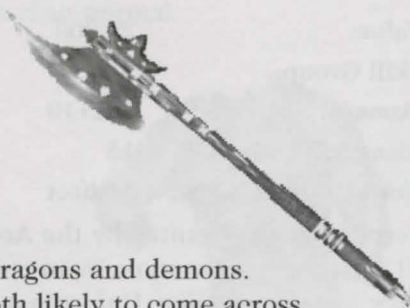

This mighty axe is enchanted to destroy dragons and demons. It has a way of finding an owner who is both likely to come across such monsters and is strong enough to fight them.

Excalibur

Value: 20,000
 Skill Group: Sword
 Damage: 3d4+12
 Identify/Repair Skill: 15
 Not Identified Name: Artifact



Heavy, yet seemingly light as a feather in skilled hands, Excalibur confers great might upon its wielder. Opponents don't easily walk away from the blows this legendary weapon strikes.

Merlin

Value:	20,000
Skill Group:	Staff
Damage:	2d4+8
Identify/Repair Skill:	15
Not Identified Name:	Artifact

Traditionally carried by the High Druid, but lost during struggles over religious doctrine, Merlin acts as a reservoir of spell power the wielder can draw upon at any time. Merlin is enchanted with swiftness, and rains blows upon enemies much faster than an ordinary staff.

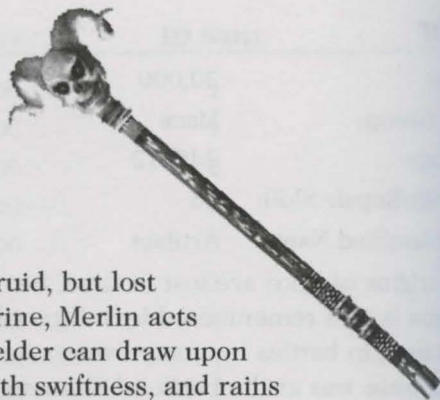

Percival

Value:	20,000
Skill Group:	Bow
Damage:	5d2+10
Identify/Repair Skill:	15
Not Identified Name:	Artifact

Percival was enchanted by the Archer's Guild in 912 A.S. as the prototype in an enchantment process they were developing. Unfortunately, a suspicious fire broke out at the guild hall, ruining the development plans and destroying the exotic materials needed to create more Percivals. The guild never recovered from the loss, and sold Percival to the Elves in 918 A.S. It has since changed hands many times.

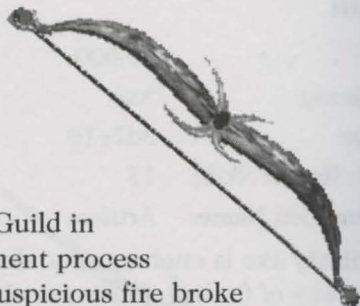



Bodily Protection

Armor

GALAHAD

Value:	20,000
Skill Group:	Chain
Armor Bonus:	6+30
Identify/Repair Skill:	15
Not Identified Name:	Artifact



Perhaps the finest chain mail created since the Silence, Galahad's material strength enchantments are so strong they confer somewhat upon the wearer's body, making it capable of withstanding much more abuse than normal.

PELLINORE

Value:	20,000
Skill Group:	Plate
Armor Bonus:	10+36
Identify/Repair Skill:	15
Not Identified Name:	Artifact



Named after an ancient knight, Pellinore fortifies the wearer with an unnatural health so strong that the wearer heals from serious injuries in a matter of hours. The armor is quite heavy, and protects the wearer from being knocked about during combat.

VALERIA

Value:	20,000
Skill Group:	Leather
Armor Bonus:	4+16
Identify/Repair Skill:	15
Not Identified Name:	Artifact



Commissioned by King David IV of Erathia during the Timber Wars, Valeria not only shields the user from normal blows, but helps intercept many incoming arrows by magically focusing the wielder's attention on the flight of the missile. The same enchantment that makes the shielding effect possible also increases the wielder's accuracy enormously.

Cloaks**PENDRAGON**

Value:	20,000
Armor Bonus:	1+10
Identify/Repair Skill:	15
Not Identified Name:	Artifact



This cape originally belonged to Alastair Blane, Master Thief of the Shadow Guild. The cape increased his luck and certain thieving skills, enabling him to pursue a long and prosperous career. Blane was never brought to justice for his crimes. Instead, he was killed in a card game for cheating while wearing the cloak to better his chances.

Boots**LUCIUS**

Value:	20,000
Armor Bonus:	2+12
Identify/Repair Skill:	15
Not Identified Name:	Artifact



No one knows where or when these magical boots were made, but many tales refer to them turning up in the most unusual places. They grant their wearer superhuman quickness and grace of motion.



Headgear

ARTHUR

Value: 20,000
 Armor Bonus: 0+5
 Identify/Repair Skill: 15
 Not Identified Name: Artifact



In their endless quest to create the perfect priest-king, the priests of the Church of the Sun created Arthur and imbued it with the power to heighten the wearer's personal abilities, as well as confer more magical energy. It worked, heightening their king's natural abilities—and his pride. In 1073 A.S. Leopold VII started a holy war against the rival Church of the Moon, grinding both organizations into poverty and ultimately resulting in their demise.

Jewelry

GUINEVERE

Value: 20,000
 Armor Bonus: 0+2
 Identify/Repair Skill: 15
 Not Identified Name: Artifact



Guinevere was created by the Alchemist's Guild under the stones of Castle Kriegspire many years ago. It boosts the magical resources available to its wearer, and eases the use of Mirrored Path spells.

IGRAINE

Value: 20,000
 Armor Bonus: 0+2
 Identify/Repair Skill: 15
 Not Identified Name: Artifact



Lord Solomon Stone had this ring commissioned during his tenure as High Priest of the Path in 1018 A.S. It gives a huge boost to a user's ability in clerical magic, as well as access to a good deal of magical energy.

MORGAN

Value:	20,000
Armor Bonus:	0+3
Identify/Repair Skill:	15
Not Identified Name:	Artifact



Though its origins are unknown, Morgan has had many owners in the last 100 years, all unknown before finding the amulet. Morgan is so mighty, any peasant or child who lays hands on it will become a legend in his or her own time.

RELICS**Weapons****Hades**

Value:	30,000
Skill Group:	Sword
Damage:	3d3+15
Identify/Repair Skill:	20
Not Identified Name:	Relic

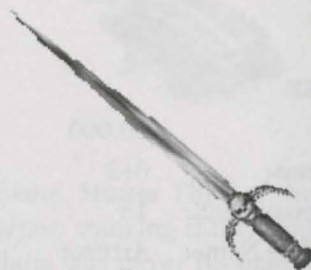

A powerful weapon said to have been delivered up from the Netherworld in response to the wish of a prolific mass murderer. The weapon inflicts terrible wounds with its razor-sharp edge and drips acid constantly. Not only a terrible weapon, the sword bestows the cunning of a Master Thief for disarming traps and the luck of the devil in escaping the damage they do. Hades draws power from its wielder slowly and constantly.

**Ares**

Value: 30,000
 Skill Group: Mace
 Damage: 2d4+14
 Identify/Repair Skill: 20
 Not Identified Name: Relic



A powerful war mace, Ares burns with fires from the heart of the mountain it was made from. The same magic that causes it to burn with a terrible fire bestows resistance to fire upon its wielder.

Poseidon

Value: 30,000
 Skill Group: Spear
 Damage: 2d6+15
 Identify/Repair Skill: 20
 Not Identified Name: Relic

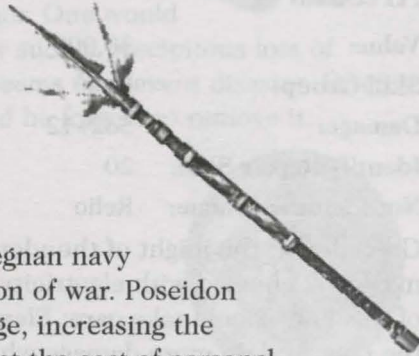

This relic probably is what inspired the Regnan navy to adopt the trident as their favorite weapon of war. Poseidon fills its wielder with a frightening battle rage, increasing the wielder's might, endurance, and accuracy at the cost of personal safety. So consuming is the wielder's desire to smite his enemies while using Poseidon that he neglects to dodge blows he might otherwise have avoided. On the other hand, dead enemies (usually) don't fight back.

Cronos

Value: 30,000
 Skill Group: Axe
 Damage: 4d2+14
 Identify/Repair Skill: 20
 Not Identified Name: Relic

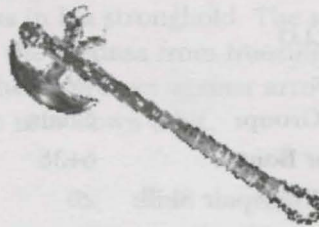

More a magical curiosity than a truly useful weapon, Cronos increases the wielder's vitality fantastically, and decreases his luck by half as much.

Hercules

Value:	30,000
Skill Group:	Sword
Damage:	4d5+12
Identify/Repair Skill:	20
Not Identified Name:	Relic

A huge sword meant for the unsubtle, Hercules fills its wielder with the strength of 100 men. In keeping with its "big and stupid" theme, the sword reduces the intelligence of its wielder.

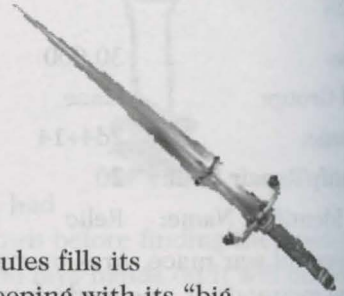

Artemis

Value:	30,000
Skill Group:	Bow
Damage:	5d2+12
Identify/Repair Skill:	20
Not Identified Name:	Relic

Graced with the might of thunder, Artemis fires bolts magically charged with electricity. While powerful, the user of this bow should take care: Elemental magics seem drawn to the bow, and do more damage when they hit the wielder.

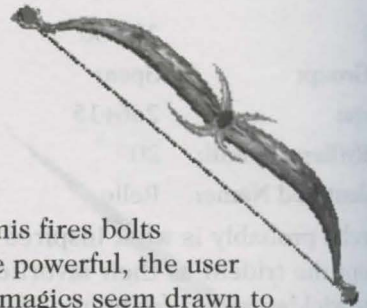

Bodily Protection

Armor

APOLLO

Value:	30,000
Skill Group:	Chain
Armor Bonus:	6+38
Identify/Repair Skill:	20
Not Identified Name:	Relic



This unique armor graces its owner with luck, helping him to escape the brunt of most elemental attacks. It draws its energy, however, from the constitution of its wearer, which makes wearing this armor a risky proposition.

**ZEUS**

Value:	30,000
Skill Group:	Plate
Armor Bonus:	10+44
Identify/Repair Skill:	20
Not Identified Name:	Relic



Perhaps this suit of armor was meant only for the gods. Worn at times by barbarian chieftains, the armor will increase the physical vitality and magical energy the wearer has at his disposal, but at a terrible cost. Houseplants have been known to score higher on intelligence tests than wearers of this armor. One would think accidental death would surely follow such a precipitous loss of thought, yet the luck the armor bestows seems to prevent disaster. Often the wearer of the armor becomes so stupid he forgets to remove it.

Shields**ÆGIS**

Value:	30,000
Skill Group:	Shield
Armor Bonus:	6+23
Identify/Repair Skill:	20
Not Identified Name:	Relic



Legend has it this shield was a gift from the gods to a man wishing to fight the terrible medusas in his stronghold. The shield is reflective and prevents the stoning gaze of the medusa from freezing the wielder. It also carries an enchantment that helps protect against arrows, but the shield is very heavy and will slow the user down a bit.

Cloaks

ATLAS

Value:	30,000
Armor Bonus:	1+15
Identify/Repair Skill:	20
Not Identified Name:	Relic



Legends say this cape was discarded by a god who became annoyed with the cape's magical slowing of his actions. It confers an incomparable might to its wearer, at a large cost to speed.

Boots

HERMES

Value:	30,000
Armor Bonus:	2+15
Identify/Repair Skill:	20
Not Identified Name:	Relic



A relic from before the Silence, these boots must conceal some hidden magic: They're very heavy, yet light once worn. They act on the nerves and muscles of their wearer, heightening his speed and reflexes to inhuman levels, but simultaneously causing inaccuracy and overcompensation. The boots have been owned by many through the ages, all of whom died from some speed-related accident, such as running up a hill at blazing speeds, right over the cliff at the top.

Headgear

ODIN

Value:	30,000
Armor Bonus:	0+10
Identify/Repair Skill:	20
Not Identified Name:	Relic



This crown is a mighty relic that protects against elemental magic attacks of all kinds, but has a flaw that slows the wearer greatly.



Jewelry

APHRODITE

Value: 30,000

Armor Bonus: 0+4

Identify/Repair Skill: 20

Not Identified Name: Relic



Desired and sought after by the foolish for ages, this beautiful ring smoothes the skin, clears the voice, and dramatically improves the physical beauty of its wearer, as well as enhancing the personality. The ring also carries a curse of ill luck, and the wearer usually dies of some tragic accident soon after finding the ring.

ATHENA

Value: 30,000

Armor Bonus: 0+4

Identify/Repair Skill: 20

Not Identified Name: Relic



Also known as the Scholar's Ring, Athena vastly sharpens and improves the intellect of its wearer at the cost of physical might. Though the effect to the physical body is nearly crippling, most sorcerers find the temptation to wear the ring too great to resist.

HERA

Value: 30,000

Armor Bonus: 0+6

Identify/Repair Skill: 20

Not Identified Name: Relic



Sometimes called the Amulet of the Fool, this curious relic from before the Silence dramatically increases the personal vitality, magical energy, and luck of the wearer at the expense of personality. While the amulet is worn, the face goes slack, the eyes vacant, and the voice subsides to a monotone.

QUEST ITEMS

Hourglass of Time

A fine hourglass made of crystal, framed with teak and filled with crushed pearl dust. It's obviously enchanted.



Sacred Chalice

A chalice of silver with white gold tracery detailing the sides and base. A faint, steady humming can be heard coming from the cup.



The Third Eye

A large, flawless, purple gem on a golden base.



Ankh

A symbolic item given by priests of Baa to signify the faithful, this ankh is inscribed with the name "Gerrard Blackames."



Candelabra

A silver candelabrum etched with symbols of Baa.



Tiger Statuette

A tiger statuette. Though highly stylized, there is something remarkably lifelike about it.



Bear Statuette

A bear statuette. Though highly stylized, there is something remarkably lifelike about it.





Wolf Statuette

A wolf statuette. Though highly stylized, there is something remarkably lifelike about it.



Eagle Statuette

An eagle statuette. Though highly stylized, there is something remarkably lifelike about it.



Dragon Statuette

A dragon statuette. Though highly stylized, there is something remarkably lifelike about it.



Dragon Claw

A claw from Longfang Witherhide's forepaw.



Control Cube

A perfectly smooth, metallic cube.



Crystal of Terrax

This stone looks as if it were cut or chipped off a much larger crystal. A faint light glimmers at its heart.



Pearl of Putrescence

This large black pearl radiates an unholy aura.



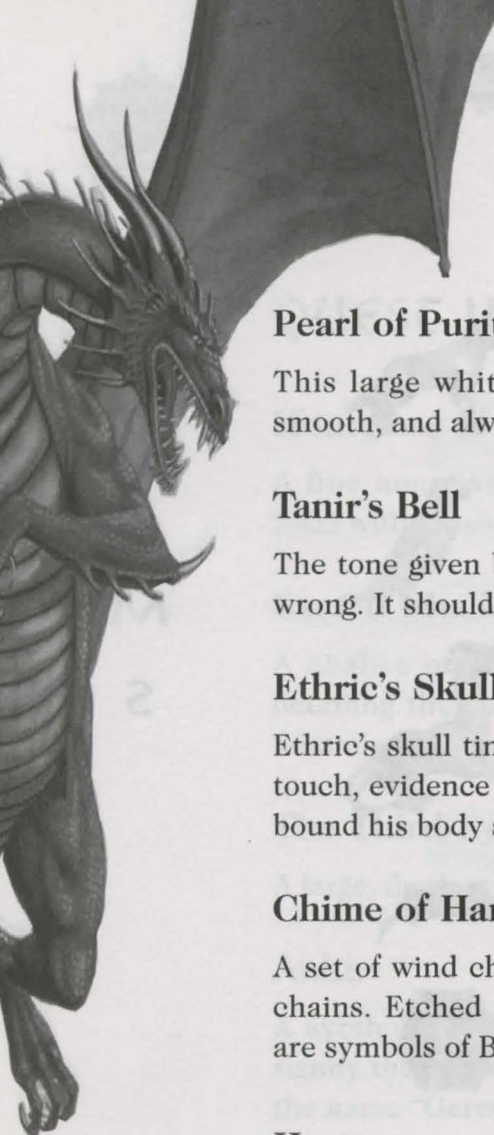

Pearl of Purity

This large white pearl is perfectly round and smooth, and always feels cool to the touch.



Tanir's Bell

The tone given by this small silver bell seems . . . wrong. It should be much higher-pitched than it is.



Ethric's Skull

Ethric's skull tingles almost imperceptibly to the touch, evidence of the powerful magics that have bound his body so long after his death.



Chime of Harmony

A set of wind chimes made of brass with copper chains. Etched along the surface of the chimes are symbols of Baa.



Harp

A beautifully carved wooden harp.



Spider Queen's Heart

A bloody trophy from the wicked Spider Queen.



Cloak of Baa

Armor Bonus: 1+4

This cloak is coal-black with a red logo of a ball pierced by a sword embroidered in the back. An ominous symbol. . . .





Dragon Tower Keys

A set of keys to the various Dragon Towers in the towns of Enroth.



Key to Gharik's Laboratory

A small key.



Key to Snergle's Chambers

A small key.



Key to Goblinwatch

A small key.



Lord Kilburn's Shield

Armor Bonus: 6+3

Identify/Repair Skill: 5

This battered and bloody shield still bears Kilburn's name etched near the bottom.



Memory Crystals: Alpha, Beta, Delta, and Epsilon

Memory Crystals Alpha, Beta, Delta, and Epsilon are data storage units for the Oracle.



Jeweled Egg

A bejeweled "egg." Though it surely has something valuable and fascinating inside, you can't open it to look.



MISCELLANEOUS ITEMS

Miscellaneous items include keys, maps, messages, pouches, potion bottles, gold, and gems. They're the mundane facts of existence for an adventuring party in *The Mandate of Heaven*. Although many of the messages and keys have names, they're mere stepping stones on the way through a quest, and not a quest item in and of themselves.

Deck of Fate

A pack of cold, heavy Tarot cards.



Gong

A small gong, used by the wealthy to summon servants.



Horseshoe

This horseshoe is made of silver, and has never been used.



Bone

A thighbone from a human or humanoid monster.



Crystal Skull

A single piece of bluish crystal, carved into the shape of a human skull.





Lodestone

A rock.



Harpy Feather

This quill appears to be from some sort of tropical bird.



Pyramid

A small, golden pyramid.



Keg

A small ale keg. This one is made of high-quality oak.



Cobra Egg

The heavy egg of a large bird or reptile—or monster.



Tooth

A large canine tooth from the mouth of some huge beast.



Four-Leaf Clover

Sure and begorra! A four-leaf clover!



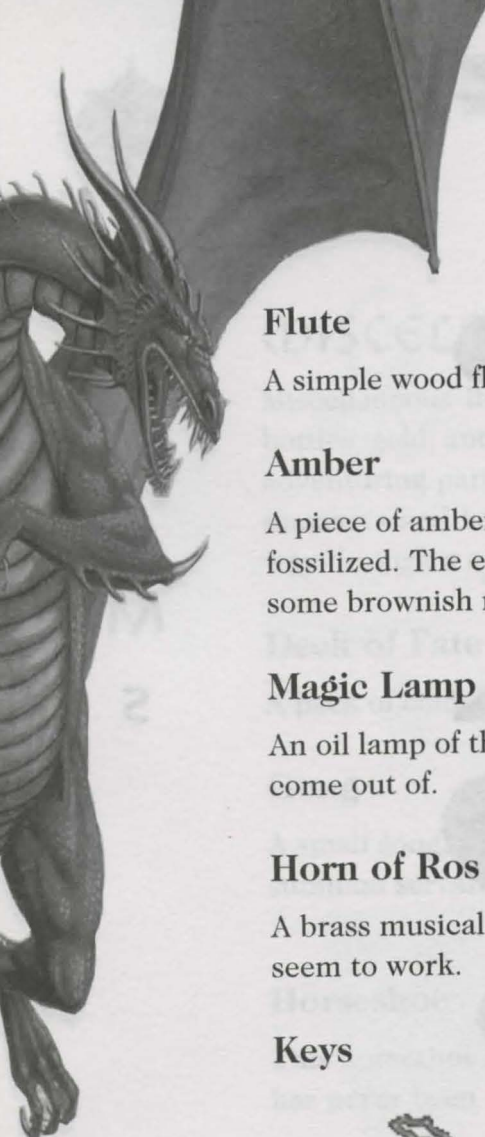

Flute

A simple wood flute rimmed with silver.



Amber

A piece of amber, long hardened and fossilized. The exterior is encrusted with some brownish mineral.



Magic Lamp

An oil lamp of the kind genies of fable come out of.



Horn of Ros

A brass musical instrument. It doesn't seem to work.



Keys



Maps





I
T
E
M
S

Messages



Gold



Potion Bottle



Leather Pouch



Gems

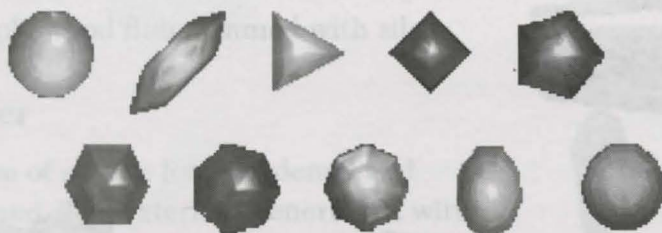

NAME	VALUE
Diamond	4,000
Moonstone	1,000
Topaz	1,200
Ruby	2,200
Amethyst	1,400
Garnet	1,600
Purple Topaz	1,800
Sunstone	2,000
Emerald	2,500
Sapphire	3,000

HOW MAGICAL ITEMS ARE GENERATED

If you read through the descriptions of the various enemies, you may have noticed that the "Treasure Carried" listing for a lot of monsters was something like "xDx+x%tt" (where x is a number and tt is a type of item). The type of treasure being generated works off a "random" number. *Might and Magic VI* uses a random number seed that's a value taken from your computer's clock cycles at startup each day. When an item is generated, a new seed is taken from the clock cycle the computer was in when the last item was generated.



L1 items are never magical, and L6 items are always magical. There are 14 standard bonuses, which weapons can never get. These bonuses appear as an “of”-type bonus, and can be any one of Might, Thought, Charm, Vigor, Precision, Speed, Luck, Health, Magic, Defense, Fire Resistance, Cold Resistance, Electricity Resistance, and Poison Resistance. They can be applied to any item that can be worn. For example, a standard bonus for an L3 amulet might be “Gothic Amulet of Speed.”

There also are special bonuses that can apply to any non-quest item, including weapons. They also have (usually) an “of”-type nomenclature, but these are more generalized names, such as “of Carnage” or “of the gods.” These special bonuses tend to be extremely powerful, although most don’t modify a character’s base statistics directly, as the standard bonuses do. L1 and L2 items carry no chance of a special bonus, but weapons are far more likely to carry a special bonus than other items.

NAME OF SPECIAL BONUS	RESULT
of Protection ¹	+10 to all Resistances
of The Gods	+10 to all Seven Statistics
of Carnage ²	Explosive Impact!
of Cold ³	Adds 3–4 points of Cold damage
of Frost ³	Adds 6–8 points of Cold damage
of Ice ³	Adds 9–12 points of Cold damage
of Sparks ³	Adds 2–5 points of Electrical damage
of Lightning ³	Adds 4–10 points of Electrical damage
of Thunderbolts ³	Adds 6–15 points of Electrical damage
of Fire ³	Adds 1–6 points of Fire damage
of Flame ³	Adds 2–12 points of Fire damage
of Infernos ³	Adds 3–18 points of Fire damage

MIGHT & MAGIC VI: The Mandate of Heaven

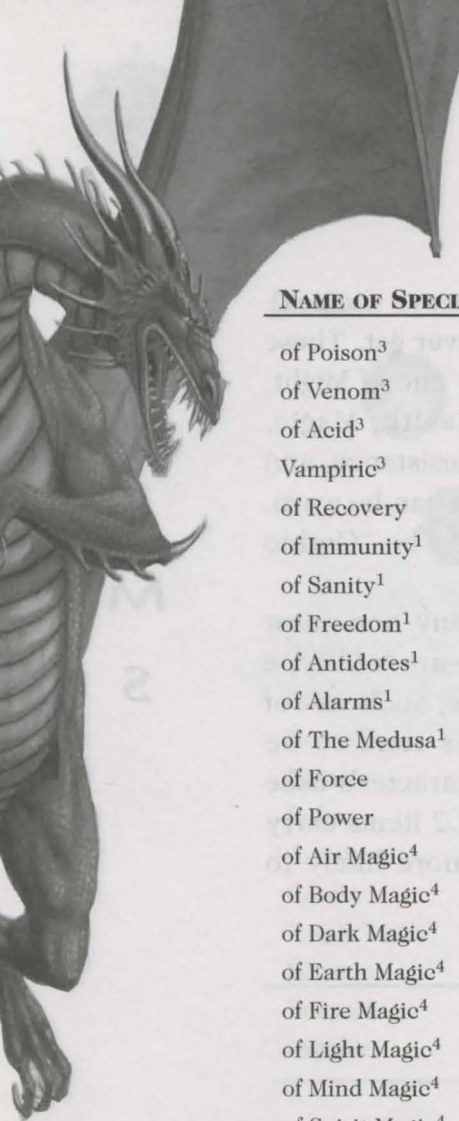

NAME OF SPECIAL BONUS	RESULT
of Poison ³	Adds 5 points of Poison damage
of Venom ³	Adds 8 points of Poison damage
of Acid ³	Adds 12 points of Poison damage
Vampiric ³	Drain Hit Points from target
of Recovery	Increases rate of Recovery
of Immunity ¹	Wearer resistant to Diseases
of Sanity ¹	Wearer resistant to Insanity
of Freedom ¹	Wearer resistant to Paralysis
of Antidotes ¹	Wearer resistant to Poison
of Alarms ¹	Wearer resistant to Sleep
of The Medusa ¹	Wearer resistant to Stone
of Force	Increased knockback
of Power	Wearer gains 5 Levels
of Air Magic ⁴	Increases effect of all Air spells
of Body Magic ⁴	Increases effect of all Body spells
of Dark Magic ⁴	Increases effect of all Dark spells
of Earth Magic ⁴	Increases effect of all Earth spells
of Fire Magic ⁴	Increases effect of all Fire spells
of Light Magic ⁴	Increases effect of all Light spells
of Mind Magic ⁴	Increases effect of all Mind spells
of Spirit Magic ⁴	Increases effect of all Spirit spells
of Water Magic ⁴	Increases effect of all Water spells
of Thievery	Increases chance of disarming traps
of Shielding	Half damage from all missile attacks
of Regeneration	Regenerate Hit points over time
of Mana	Regenerate Spell points over time
Demon Slayer ³	Double damage vs Demons
Dragon Slayer ³	Double damage vs Dragons
of Darkness ³	Drain Hit Points from target and Increased Weapon speed
of Doom	+1 to Seven Stats, HP, SP, Armor, Resistances
of Earth	+10 to Endurance, Armor, Hit points
of Life	+10 Hit points and Regenerate Hit points over time

CHAPTER 5 Items



I T E M S

NAME OF SPECIAL BONUS	RESULT
Rogue's	+5 Speed and Accuracy
of The Dragon ³	Adds 10–20 points of Fire damage and +25 Might
of The Eclipse ¹	+10 Spell points and Regenerate Spell points over time
of The Golem	+15 Endurance and +5 Armor
of The Moon	+10 Intellect and Luck
of The Phoenix ¹	+30 Fire Resistance and Regenerate Hit points over time
of The Sky	+10 Spell points, Speed, Intellect
of The Stars	+10 Endurance and Accuracy
of The Sun	+10 Might and Personality
of The Troll	+15 Endurance and Regenerate Hit points over time
of The Unicorn	+15 Luck and Regenerate Spell points over time
Warrior's	+5 Might and Endurance
Wizard's	+5 Intellect and Personality
Antique	Increased Value
of Swiftess ³	Increased Weapon speed

¹Bodily Protection items only

²Bows only

³Weapons only

⁴Jewelry only

Note that the most difficult special bonus to get is the “of Power” bonus. Even though there’s a chance any item type can be imbued with this bonus, the base percentage chance of this is only 2 percent. Also, this bonus applies only to treasures of L5 or better. Therefore, if you happen to get lucky enough to find something with this bonus, you might want to hang onto it.

YE OLDE ALCHEMICAL SHOPPE

Mixing potions in *The Mandate of Heaven* can be rewarding, but it can also be dangerous. Use the following tables to make sure you don't get into trouble!

Herbalism Reference

NAME	NOT IDENTIFIED NAME	EFFECT OF INGESTION
Poppysnaps	Herb	Restores 2 Hit points
Phirna Root	Herb	Restores 2 Spell points
Widoweeps Berries	Herb	Set condition to Poisoned
Potion Bottle	—	No effect
Potion of Cure Wounds	Red Potion	Restores 10 Hit points
Magic Potion	Blue Potion	Restores 10 Spell points
Potion of Energy	Yellow Potion	Set all 7 primary stats to +10 temporarily, not cumulative
Potion of Protection	Orange Potion	Set Armor Class to +10 temporarily, not cumulative
Potion of Resistance	Green Potion	Set resistances to Fire, Cold, Electricity, and Poison to +10 temporarily, not cumulative
Potion of Cure Poison	Purple Potion	Cures the Poisoned condition
Potion of Supreme Protection	White Potion	Set Armor Class to +20 temporarily, not cumulative
Potion of Restoration	White Potion	Cure all conditions except dead, stoned, or eradicated
Potion of Extreme Energy	White Potion	Set all 7 primary stats to +20 temporarily, not cumulative

CHAPTER 5 Items



I T E M S

NAME	NOT IDENTIFIED NAME	EFFECT OF INGESTION
Potion of Super Resistance	White Potion	Set resistances to Fire, Cold, Electricity, and Poison to +20 temporarily, not cumulative
Potion of Heroism	White Potion	Set Heroism to 6 hours
Potion of Haste	White Potion	Set Haste to 6 hours
Potion of Stone Skin	White Potion	Set Stone Skin to 6 hours
Potion of Bless	White Potion	Set Bless to 6 hours
Potion of Divine Power	Black Potion	Sets Level to +20 temporarily, character ages 1 year temporarily, not cumulative
Potion of Divine Cure	Black Potion	Hit points +100, character ages 1 year temporarily
Potion of Divine Magic	Black Potion	Spell points +100, character ages 1 year temporarily
Potion of Pure Might	Black Potion	Might +15 permanently, Intellect -5 permanently, 1 time only
Potion of Pure Intellect	Black Potion	Intellect +15 permanently, Might -5 permanently, 1 time only
Potion of Pure Personality	Black Potion	Personality +15 permanently, Speed -5 permanently, 1 time only
Potion of Pure Endurance	Black Potion	Endurance +15 permanently, -1 all other primary stats permanently, 1 time only
Potion of Pure Accuracy	Black Potion	Accuracy +15 permanently, Luck -5 permanently, 1 time only
Potion of Pure Speed	Black Potion	Speed +15 permanently, Personality -5 permanently, 1 time only
Potion of Pure Luck	Black Potion	Luck +15 permanently, Accuracy -5 permanently, 1 time only
Potion of Rejuvenation	Black Potion	Restore character's age to actual age, -1 all 7 stats permanently

Mixtures, Tinctures, and Philtres

Note that these are the only safe mixtures when dealing with herbs and potions. Any other combination will result in a loss of both items, at best, and an explosion, at worst. In particular, avoid mixing White Potions with Black Potions.

FIRST ITEM	SECOND ITEM	RESULT
Poppynaps	Potion Bottle	Potion of Cure Wounds
Phirna Root	Potion Bottle	Magic Potion
Widoweeps Berries	Potion Bottle	Potion of Energy
Potion of Cure Wounds	Magic Potion	Potion of Cure Poison
Potion of Cure Wounds	Potion of Energy	Potion of Protection
Potion of Cure Wounds	Potion of Protection	Potion of Heroism
Potion of Cure Wounds	Potion of Heroism	Potion of Essence of Might
Potion of Cure Wounds	Potion of Haste	Potion of Essence of Speed
Magic Potion	Potion of Energy	Potion of Resistance
Magic Potion	Potion of Protection	Potion of Stone Skin
Magic Potion	Potion of Resistance	Potion of Super Resistance
Magic Potion	Potion of Cure Poison	Potion of Bless
Magic Potion	Potion of Restoration	Potion of Essence of Personality
Magic Potion	Potion of Stone Skin	Potion of Essence of Intellect
Potion of Energy	Potion of Protection	Potion of Extreme Energy
Potion of Energy	Potion of Resistance	Potion of Haste
Potion of Energy	Potion of Supreme Protection	Potion of Essence of Endurance
Potion of Energy	Potion of Bless	Potion of Essence of Accuracy

CHAPTER 5 Items



I T E M S

FIRST ITEM	SECOND ITEM	RESULT
Potion of Protection	Potion of Resistance	Potion of Supreme Protection
Potion of Protection	Potion of Restoration	Potion of Divine Cure
Potion of Resistance	Potion of Cure Poison	Potion of Restoration
Potion of Resistance	Potion of Extreme Energy	Potion of Rejuvenation
Potion of Resistance	Potion of Super Resistance	Potion of Divine Magic
Potion of Cure Poison	Potion of Extreme Energy	Potion of Divine Power
Potion of Cure Poison	Potion of Super Resistance	Potion of Essence of Luck



"JACKALMAN"
- APRIL -



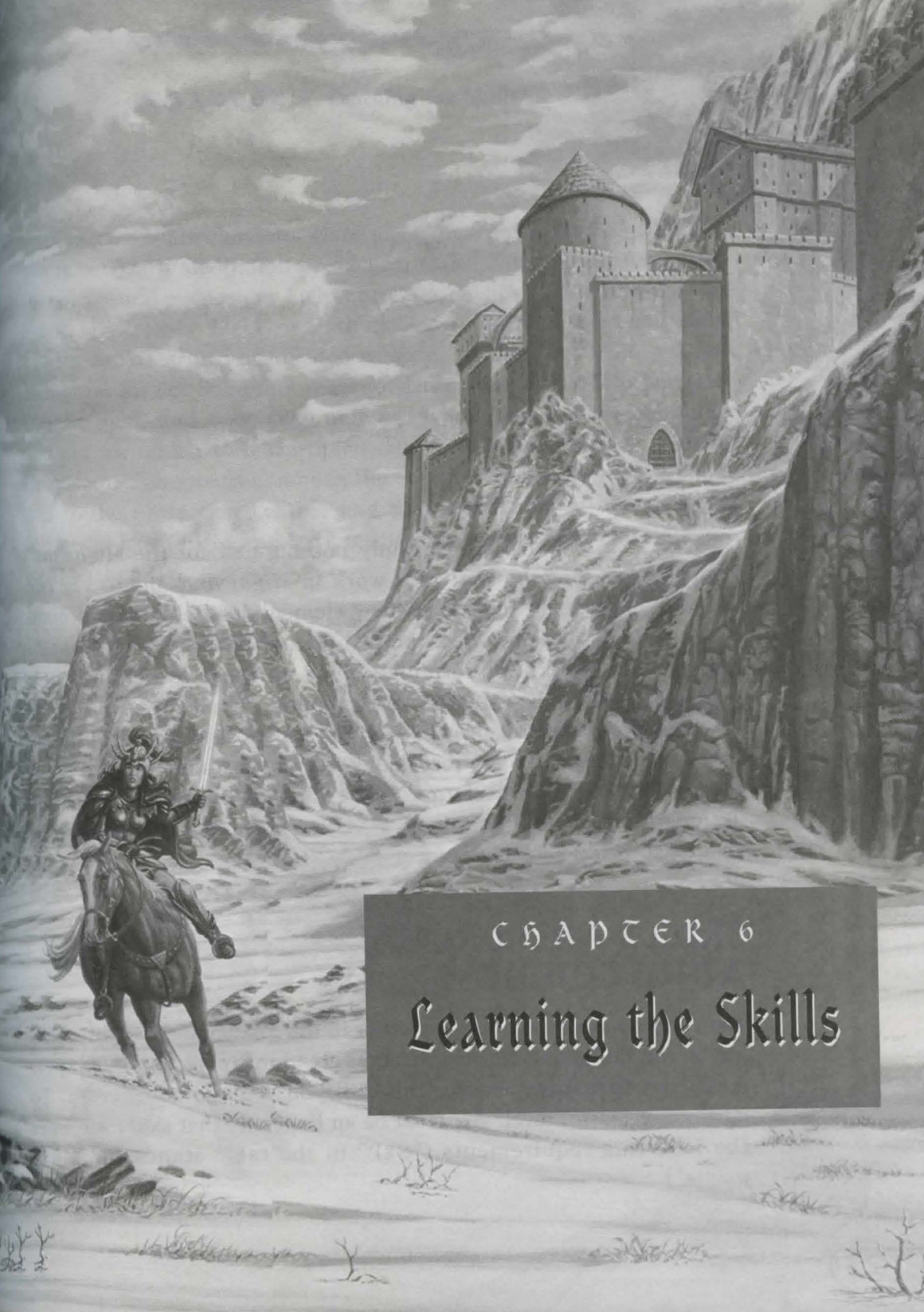

CHAPTER 6

Learning the Skills



kills are certainly nothing new for the *Might and Magic* series, but the way they work in *Might and Magic VI: The Mandate of Heaven* introduces new elements of richness and complexity. Now the game incorporates distinct levels of prowess, and many of its underlying formulae hinge on these levels and their accompanying point system to work properly.

The three levels of prowess—Base, Expert, and Master—dictate how certain situations are resolved, and with what amount of relative ease a character may perform a task related to the skill in question. To function properly, the game's AI engine must consider skill points that exist within each level of prowess.

SKILLS AND PROWESS ADJUSTMENTS

You can find skills descriptions either in the manual or by right-clicking on the skill name during character creation. To advance to Expert level, you first must acquire the skill you want to advance in. To advance to Master level, you must be an Expert in that skill *and* meet the following requirements (“SkP” in the table stands for “skill points”).

CHAPTER 6 Learning the Skills



S K I L L S

Note that some character classes can't learn certain skills. Knights can never learn Meditation or magical skills. Paladins can learn neither elemental magics nor Light and Dark magics. Archers can't learn Spirit, Mind, Body, Light, or Dark magics, nor Shield and Plate skills. Clerics can't learn to use bladed weapons or the Plate skill, nor any elemental magic. Sorcerers may not learn weapon skills other than Dagger, Staff, and Bow; they may not learn Armor or Shield skills, and are forbidden to learn Spirit, Mind, and Body magics. Finally, Druids must choose from among the Sorcerer's weapons, and are limited to the protection Leather and Shield skills afford them. Druids can never learn Light and Dark magic, but all other magical skills are open to them.



MIGHT & MAGIC VI: The Mandate of Heaven

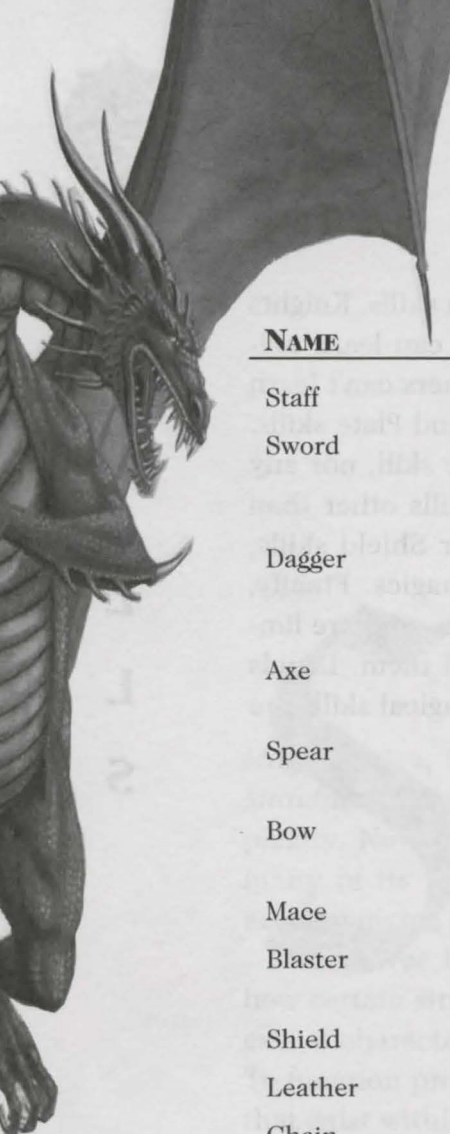

NAME	EXPERT ADJUSTMENT	REQUIREMENTS AND COST FOR EXPERT ADVANCEMENT
Staff	Increases armor class	4 SkP in Staff, 2000gp
Sword	Quicker attack	4 SkP in Sword, 2000gp
Dagger	Wield a dagger in left hand while using another one-handed weapon in right hand	4 SkP in Dagger, 2000gp
Axe	Extra attack speed	4 SkP in Axe, 2000gp
Spear	Increases armor class	4 SkP in Spear, 2000gp
Bow	Increases weapon speed	4 SkP in Bow, 2000gp
Mace	Extra damage	4 SkP in Mace, 2000gp
Blaster	Double accuracy	4 SkP in Blaster, 2000gp
Shield	Increases armor class	4 SkP in Shield, 2000gp
Leather	Increases recovery speed	4 SkP in Leather, 1000gp
Chain	Increases recovery speed	4 SkP in Chain, 1000gp
Plate	Increases recovery speed	4 SkP in Plate, 1000gp
Fire	Access to more advanced fire spells	4 SkP in Fire, 1000gp
Air	Access to more advanced air spells	4 SkP in Air, 1000gp
Water	Access to more advanced water spells	4 SkP in Water, 1000gp

CHAPTER 6 Learning the Skills



S K I L L S

MASTER ADJUSTMENT	REQUIREMENTS AND COST FOR MASTER ADVANCEMENT
Chance to stun opponents	8 SkP in Staff, 5000gp
Use any one-handed sword in left hand and another one-handed weapon in right hand	8 SkP in Sword, Cavalier or Honorary Cavalier status, free
Chance of triple damage attack	Speed 40+, 8 SkP in Dagger, 5000gp
Extra damage	Must complete Snergle quest, free
Extra damage	8 SkP in Spear, Cavalier or Honorary Cavalier status, 5000gp
Two arrows per attack	8 SkP in Bow, Battle Mage or Honorary Battle Mage, free
Chance to stun opponents	8 SkP in Mace, Might 40+, 5000gp
Triple accuracy	8 SkP in Blaster, must have blaster in inventory or equipped, 5000gp
Increases armor class	10 SkP in Shield, 5000gp
Increases recovery speed	10 SkP in Leather, 3000gp
Increases recovery speed	10 SkP in Chain, Crusader or Honorary Crusader status, free
Increases recovery speed	Hero or Honorary Hero status, free
Access to more advanced fire spells	12 SkP in Fire, 4000gp
Access to more advanced air spells	Archmage or Honorary Archmage status, 4000gp
Access to more advanced water spells	12 SkP in Water, 4000gp

MIGHT & MAGIC VI: The Mandate of Heaven



NAME	EXPERT ADJUSTMENT	REQUIREMENTS AND COST FOR EXPERT ADVANCEMENT
Earth	Access to more advanced earth spells	4 SkP in Earth, 1000gp
Spirit	Access to more advanced spirit spells	4 SkP in Spirit, 1000gp
Mind	Access to more advanced mind spells	4 SkP in Mind, 1000gp
Body	Access to more advanced body spells	4 SkP in Body, 1000gp
Light	Access to more advanced light spells	4 SkP in Light, 2000gp
Dark	Access to more advanced dark spells	4 SkP in Dark, 2000gp
Identify	Increases chance to identify an item	4 SkP in Identify, 500gp
Merchant	Increases buying and selling skill	4 SkP in Merchant, 2000gp
Repair	Can repair complex items	4 SkP in Repair, 500gp
Bodybuilding	Doubles hit points earned in level advancement	4 SkP in Bodybuilding, 500gp
Meditation	Doubles spell points earned in level advancement	4 SkP in Meditation, 500gp
Perception	Increases ability to avoid damage when traps are triggered	4 SkP in Perception, 500gp
Diplomacy	Doubles effect	4 SkP in Diplomacy, 500gp
Disarm Traps	Doubles chance to disarm a trap	4 SkP in Disarm Traps, 500gp
Learning	Doubles the number of bonus experience points awarded to a character	4 SkP in Learning, 2000gp

CHAPTER 6 Learning the Skills



S K I L L S

MASTER ADJUSTMENT	REQUIREMENTS AND COST FOR MASTER ADVANCEMENT
Access to more advanced earth spells	12 SkP in Earth, 4000gp
Access to more advanced spirit spells	High Priest or Honorary High Priest status, free
Access to more advanced mind spells	12 SkP in Mind, 4000gp
Access to more advanced body spells	12 SkP in Body, 4000gp
Access to more advanced light spells	Saintly reputation, free
Access to more advanced dark spells	Notorious reputation, free
Increases chance to identify an item	7 SkP in Identify, Intellect 30+, 2500gp
Increases buying and selling skill	7 SkP in Merchant, Personality 30+, 4000gp
Can repair artifacts	7 SkP in Repair, Accuracy 30+, 2500gp
Triples hit points earned in level advancement	7 SkP in Bodybuilding, Endurance 30+, 2500gp
Triples spell points earned in level advancement	7 SkP in Meditation, Personality 30+, 2500gp
Increases ability to avoid damage when traps are triggered	7 SkP in Perception, Luck 30+, 2500gp
Triples effect	7 SkP in Diplomacy, Fame 200+, 2500gp
Triples chance to disarm a trap	7 SkP in Disarm Traps, Accuracy 30+, 2500gp
Triples the number of bonus experience points awarded to a character	7 SkP in Learning, Intellect 30+, 5000gp



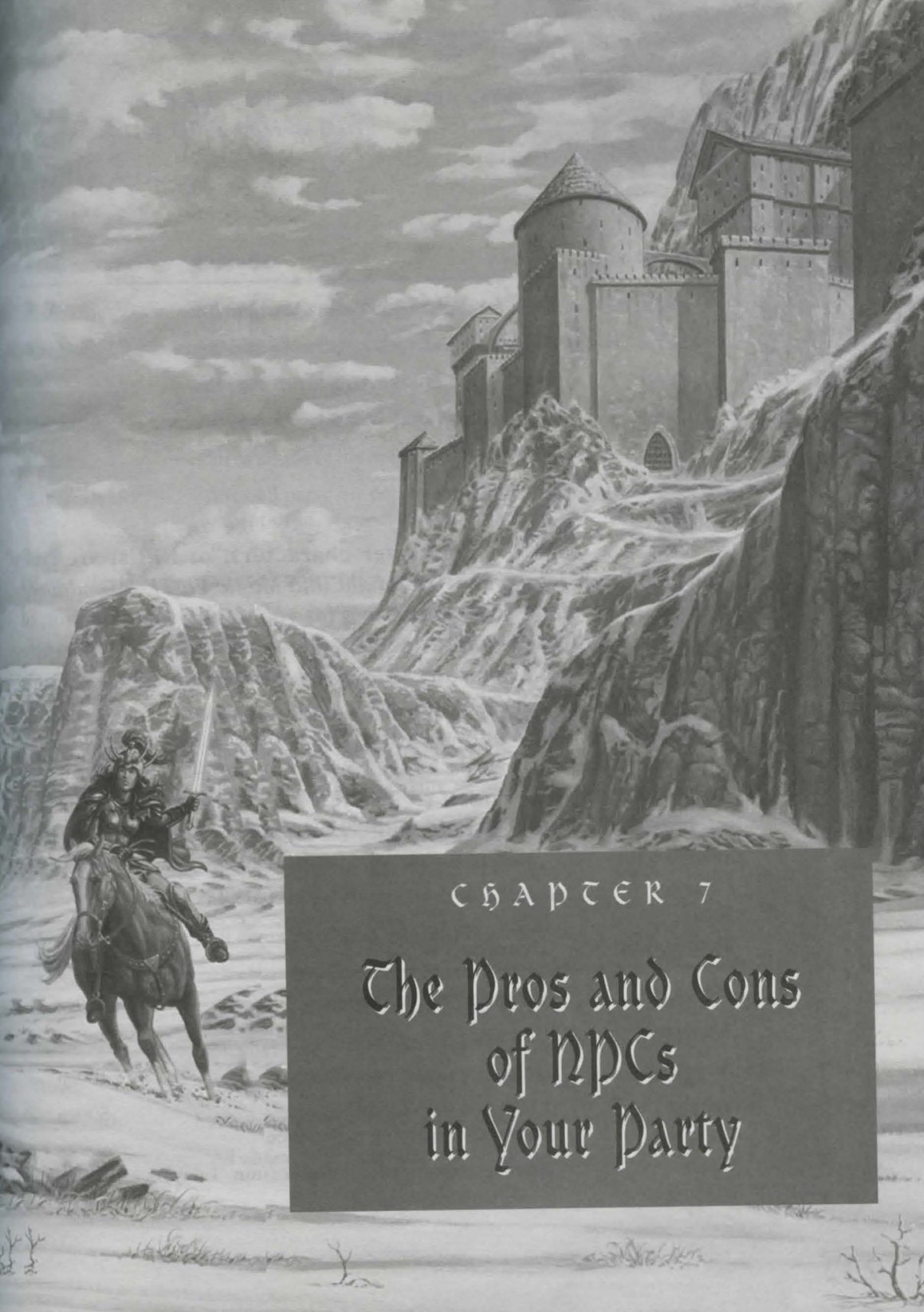

CHAPTER 7

The Pros and Cons
of NPCs
in Your Party



Nonplayer characters, or NPCs, are rich sources of both good and evil in *Might and Magic VI: The Mandate of Heaven*. Most offer healthy incentives for you to hire them on, but, of course, most of them want a percentage of the cut, too. One—the Burglar—offers to accompany your party with (seemingly) no profit to himself. What's a hero to do?

This section deals only with the NPCs you can hire to travel with your party, and disregards NPCs you might simply pick up in the course of completing a quest (Prince Nocolai, for example). You won't find specific NPC names here, either; the game generates those randomly.

NPC Profession	Benefits	Cost to start
Smith	Unlimited weapon repair	200gp
Armorer	Unlimited armor repair	200gp
Alchemist	Unlimited magic item repair	400gp
Scholar	Unlimited item identification, 5% bonus to gaining experience	500gp
Guide	All map crossings 1 day faster (min. 1 day)	100gp

CHAPTER 7 The Pros and Cons of NPCs in Your Party



N P C S

NPC Profession	Benefits	Cost to start
Tracker	All map crossings 2 days faster (min. 1 day)	200gp
Pathfinder	All map crossings 3 days faster (min. 1 day)	300gp
Sailor	All boat travel 2 days faster (min. 1 day)	100gp
Navigator	All boat travel 2 days faster (min. 1 day)	200gp
Healer	Cures all party hit points once/day	500gp
Expert Healer	Cures all party hit points and conditions (except dead, stoned, or eradicated) once/day	2000gp
Master Healer	Cures all party hit points and conditions once/day	5000gp
Teacher	10% bonus on experience points earned	300gp
Instructor	15% bonus on experience points earned	700gp
Arms Master	All characters' weapon skills +2 points	300gp
Weapons Master	All characters' weapon skills +3 points	400gp
Apprentice	All characters' magic skills +2 points	500gp
Mystic	All characters' magic skills +3 points	1000gp
Spell Master	All characters' magic skills +4 points	2000gp
Trader	All characters' Merchant skills +4 points	100gp
Merchant	All characters' Merchant skills +6 points	200gp
Scout	All characters' Perception skills +4 points	300gp
Counselor	All characters' Diplomacy skills +4 points	200gp
Barrister	All characters' Diplomacy skills +8 points	300gp
Tinker	All characters' Disarm Traps skills +4 points	200gp
Locksmith	All characters' Disarm Traps skills +6 points	300gp
Fool	All characters' Luck stat +5	100gp

MIGHT & MAGIC VI: The Mandate of Heaven

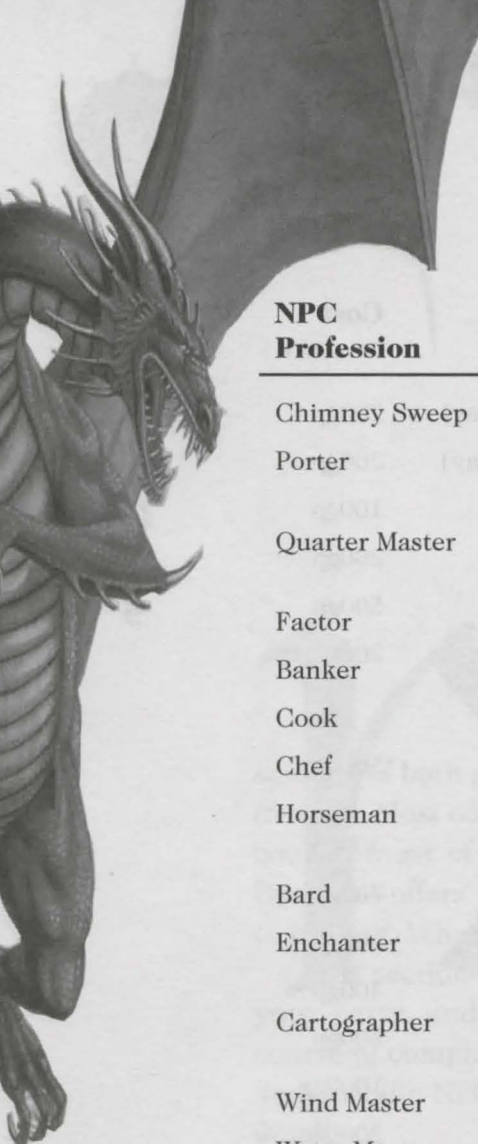

NPC Profession	Benefits	Cost to start
Chimney Sweep	All characters' Luck stat +20	200gp
Porter	One less day of food used when camping (min. 1 used)	100gp
Quarter Master	Two less days of food used when camping (min. 1 used)	200gp
Factor	10% bonus on all gold found	500gp
Banker	20% bonus on all gold found	1000gp
Cook	Makes one day of food/day (max. 14 days)	300gp
Chef	Makes two days of food/day (max. 14 days)	400gp
Horseman	Travel from stables reduced by two days (min. 1 day)	100gp
Bard	Increases party's reputation by one level	1000gp
Enchanter	Increases party's elemental protection by 20%	1000gp
Cartographer	Keeps an expert-level Wizard Eye spell up at all times	200gp
Wind Master	Casts a 2-hour-long Fly spell once/day	2000gp
Water Master	Casts a 3-hour-long Water Walk spell once/day	1000gp
Gate Master	Casts a master-level Town Portal spell once/day	2000gp
Acolyte	Casts a 2-hour long master-level Bless spell once/day	200gp
Piper	Casts a 2-hour long master-level Heroism spell once/day	300gp
Explorer	All travel times reduced by 1 day (min. 1 day)	100gp

CHAPTER 7 The Pros and Cons of NPCs in Your Party



N

P

C

S

NPC Profession	Benefits	Cost to start
Pirate	All boat travel reduced by 2 days (min. 1 day), gold increased by 10% when found, reputation decreased by one full category	500gp
Squire	All characters' armor and weapon skills +2 points	600gp
Psychic	All characters' Perception skill +5 and Luck stat +10	400gp
Gypsy	One less day of food used when resting (min. 1 used), all characters' Merchant skill +3 points, reputation decreased by one full category	100gp
Negotiator	All characters' Merchant and Diplomacy skills +4 points	500gp
Duper	All characters' Merchant skill +8 points, reputation decreased by one full category	200gp
Burglar	All characters' Disarm Traps skill +8 points, reputation decreased by one full category	Nothing*

*An important note: Never trust a burglar! Although he says it will cost you nothing to have him join your party, he actually skims 20 percent of your gold when you acquire it.



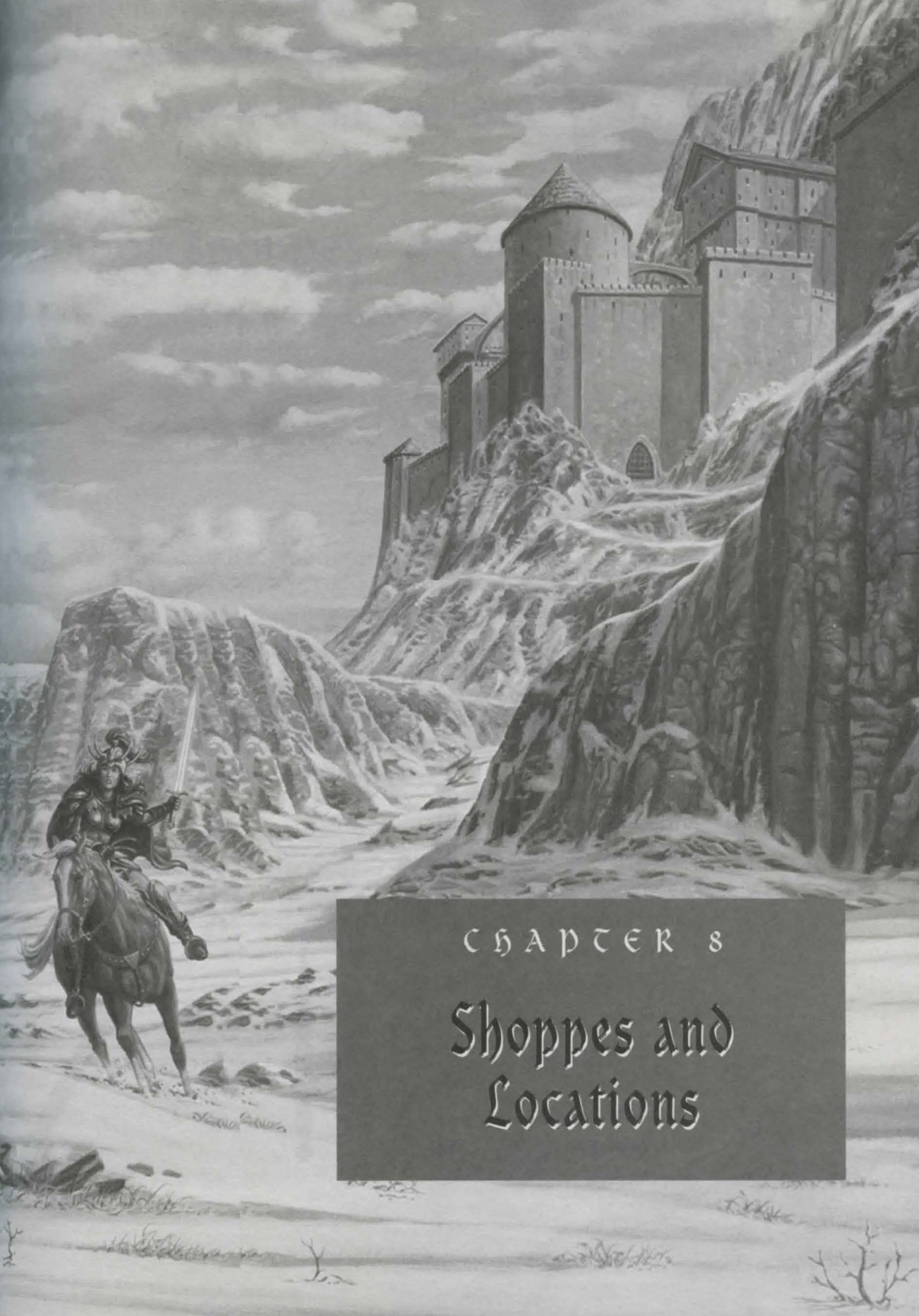

CHAPTER 8

Shoppes and
Locations



The following quick-and-dirty tables indicate where, by shop type, you can purchase almost any game item, and list which maps hold which dungeons.

NAME	MAP GRID
Sweet Water	A1
Paradise Valley	A2
Hermit's Isle	A3
Kriegspire	B1
Blackshire	B2
Dragonsand	B3
Frozen highlands	C1
Free Haven	C2
Mire of the Damned	C3
Silver Cove	D1
Bootleg Bay	D2
Castle Ironfist	D3
Eel-Infested Waters	E1
Misty Islands	E2
New Sorpigal	E3



WEAPON SHOPPES

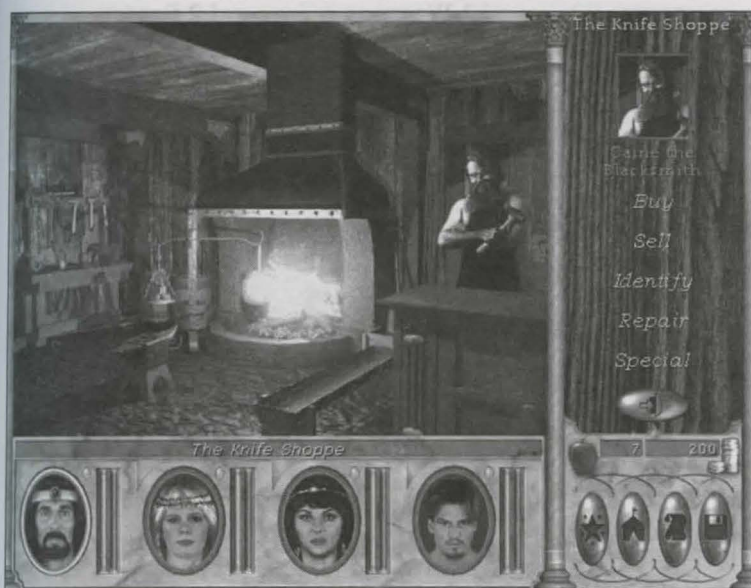
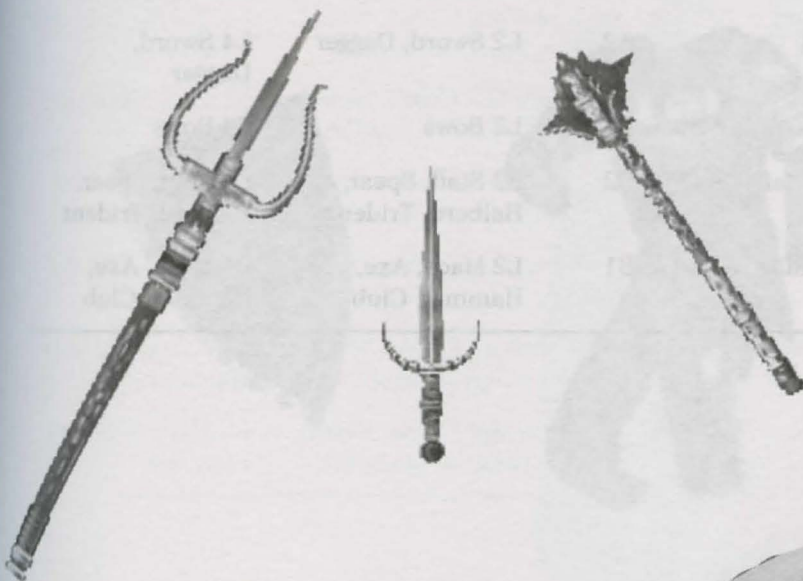
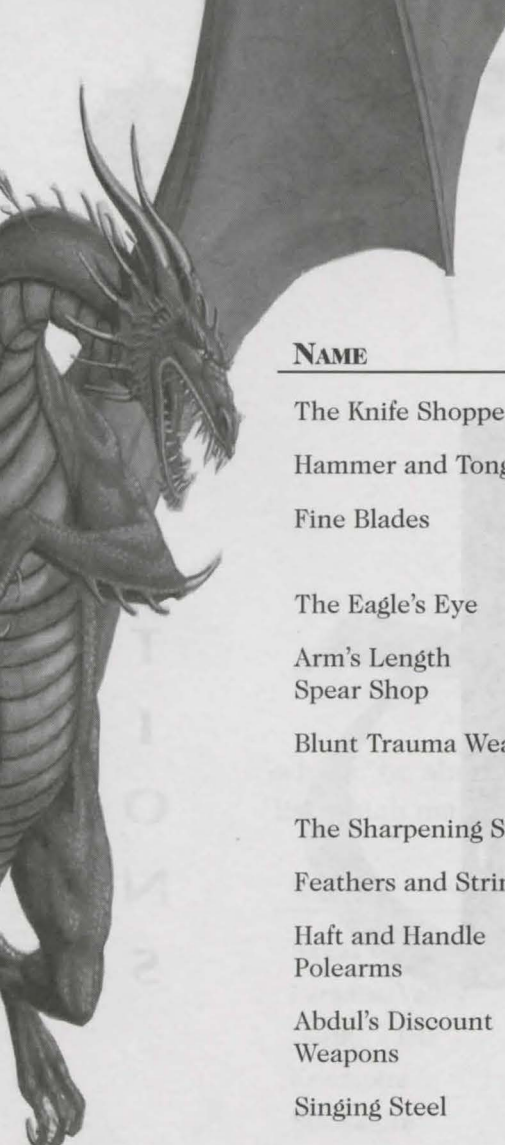

Figure 8-1 *The Knife Shoppe* in *New Sorpigal*



MIGHT & MAGIC VI: The Mandate of Heaven



NAME	MAP GRID	ORDINARY ITEMS	SPECIALS
The Knife Shoppe	E3	L1 Weapons	L2 Dagger
Hammer and Tongs	D2	L2 Weapons	L2 Mace
Fine Blades	D3	L1 Sword, Dagger	L2 Sword, Dagger
The Eagle's Eye	D3	L1 Bows	L2 Bows
Arm's Length Spear Shop	E2	L1 Staff, Spear, Halberd, Trident	L2 Staff, Spear, Halberd, Trident
Blunt Trauma Weapons	C3	L1 Mace, Axe, Hammer, Club	L2 Mace, Axe, Hammer, Club
The Sharpening Stone	C2	L2 Sword, Dagger	L3 Sword, Dagger
Feathers and String	C2	L2 Bows	L3 Bows
Haft and Handle Polearms	C1,R	L2 Staff, Spear, Halberd, Trident	L3 Staff, Spear, Halberd, Trident
Abdul's Discount Weapons	D1	L2 Mace, Axe, Hammer, Club	L3 Mace, Axe, Hammer, Club
Singing Steel	A2	L2 Sword, Dagger	L4 Sword, Dagger
Mark and Missile	C1	L2 Bows	L4 Bows
Stout Heart Staff and Spear	B2	L2 Staff, Spear, Halberd, Trident	L4 Staff, Spear, Halberd, Trident
Knight's Paradise	B1	L2 Mace, Axe, Hammer, Club	L4 Mace, Axe, Hammer, Club



ARMOR SHOPPES



Figure 8-2 *The Common Defense* in *New Sorpigal*



MIGHT & MAGIC VI: The Mandate of Heaven



NAME	MAP GRID	ORDINARY ITEMS	SPECIALS
The Common Defense	E3	L1 Leather, Chain, Shield, Helm or Gauntlet	L2 Leather, Shield, Helm or Gauntlet
Armor Emporium	E2	L2 Leather, Chain, Shield, Helm or Gauntlet	L3 Leather, Shield, Helm or Gauntlet
Metalweave Armory	D3	L2 Leather, Chain, Shield, Helm or Gauntlet	L3 Leather, Helm or Gauntlet
Abraham's Metalworks	D2	L2 Leather, Chain, Shield, Helm or Gauntlet	L3 Chain, Helm or Gauntlet
Mailed Fist Armory	C3	L2 Leather, Chain, Shield, Helm or Gauntlet	L3 Shield, Helm or Gauntlet
The Foundry	C2	L2 Leather, Chain, Shield, Helm or Gauntlet	L3 Plate, Helm or Gauntlet
Iron Defense	D3	L3 Leather, Chain, Shield, Plate, Helm or Gauntlet	L4 Leather, Helm or Gauntlet
Abdul's Discount Armor	D1	L3 Leather, Chain, Shield, Plate, Helm or Gauntlet	L4 Chain, Helm or Gauntlet
Quality Armor	C1,R	L3 Leather, Chain, Shield, Plate, Helm or Gauntlet	L4 Shield, Helm or Gauntlet
Mail and Greaves	B2	L3 Leather, Chain, Shield, Plate, Helm or Gauntlet	L4 Plate, Helm or Gauntlet
The Footman's Friend	C2	L3 Leather, Chain, Shield, Plate, Helm or Gauntlet	L4 Leather, Helm or Gauntlet
Armorworks	B1	L3 Leather, Chain, Shield, Plate, Helm or Gauntlet	L4 Chain, Helm or Gauntlet
Silver Lining Armor & Shield	C1	L3 Leather, Chain, Shield, Plate, Helm or Gauntlet	L4 Shield, Helm or Gauntlet
The Enchanted Hauberk	A2	L4 Leather, Chain, Shield, Plate, Helm or Gauntlet	L5 Plate, Helm or Gauntlet



MAGIC SHOPPES

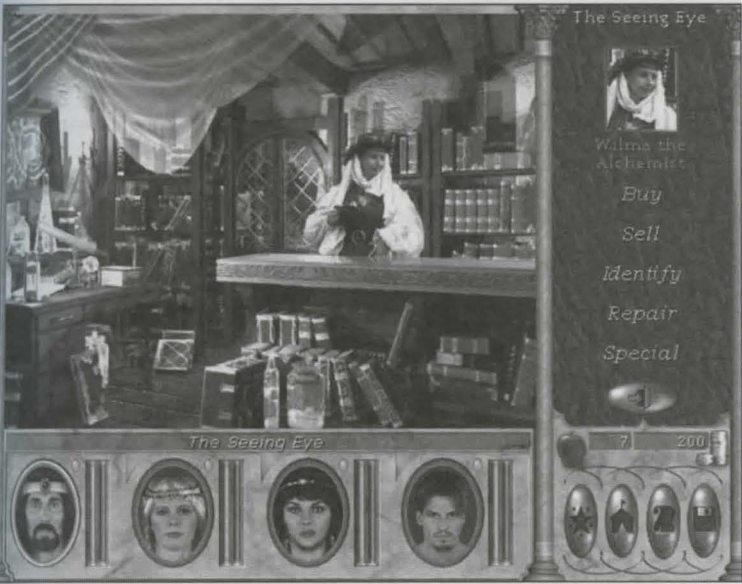
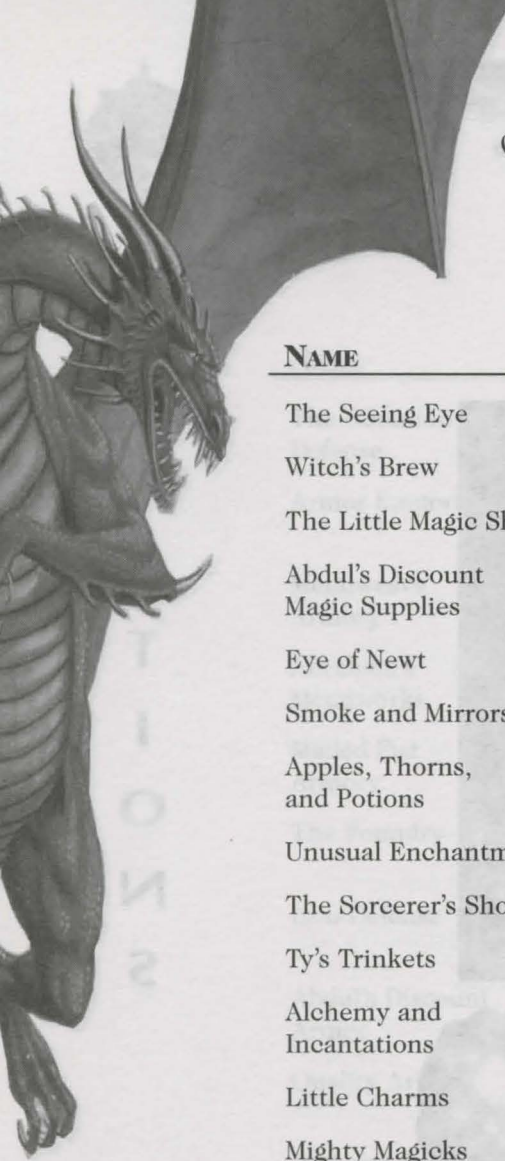

Figure 8-3 The Seeing Eye in New Soppigal



MIGHT & MAGIC VI: The Mandate of Heaven



NAME	MAP GRID	ORDINARY ITEMS	SPECIALS
The Seeing Eye	E3	L1 Miscellaneous	L2 Miscellaneous
Witch's Brew	E2	L1 Miscellaneous	L2 Miscellaneous
The Little Magic Shop	D2	L1 Miscellaneous	L2 Miscellaneous
Abdul's Discount Magic Supplies	D1	L1 Miscellaneous	L2 Miscellaneous
Eye of Newt	D3	L2 Miscellaneous	L3 Miscellaneous
Smoke and Mirrors	C3	L2 Miscellaneous	L3 Miscellaneous
Apples, Thorns, and Potions	C1	L2 Miscellaneous	L3 Miscellaneous
Unusual Enchantments	B1	L3 Miscellaneous	L3 Miscellaneous
The Sorcerer's Shoppe	C2	L3 Miscellaneous	L4 Miscellaneous
Ty's Trinkets	B2	L3 Miscellaneous	L4 Miscellaneous
Alchemy and Incantations	C2	L4 Miscellaneous	L4 Miscellaneous
Little Charms	E1	L4 Miscellaneous	L5 Miscellaneous
Mighty Magicks	A2	L5 Miscellaneous	L5 Miscellaneous



GENERAL STORES

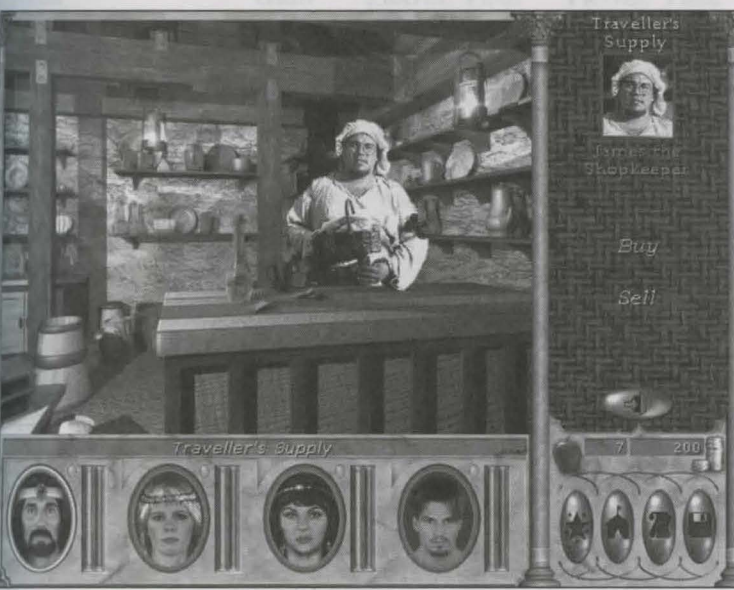
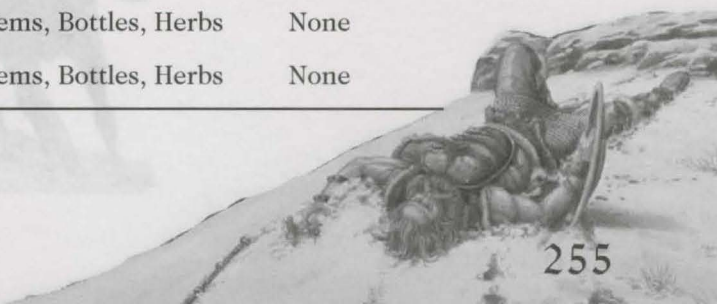

Figure 8-4 Traveller's Supply in New Sorpigal

NAME	MAP GRID	ORDINARY ITEMS	SPECIALS
Traveller's Supply	E3	L1 Items, Bottles, Herbs	None
Lock, Stock, and Barrel	E2	L1 Items, Bottles, Herbs	None
Trader Joe's	D1	L1 Items, Bottles, Herbs	None
Abdul's Discount Goods	C2	L1 Items, Bottles, Herbs	None
General Store	C1	L1 Items, Bottles, Herbs	None
Outland Trading Post	B2	L1 Items, Bottles, Herbs	None



STABLES

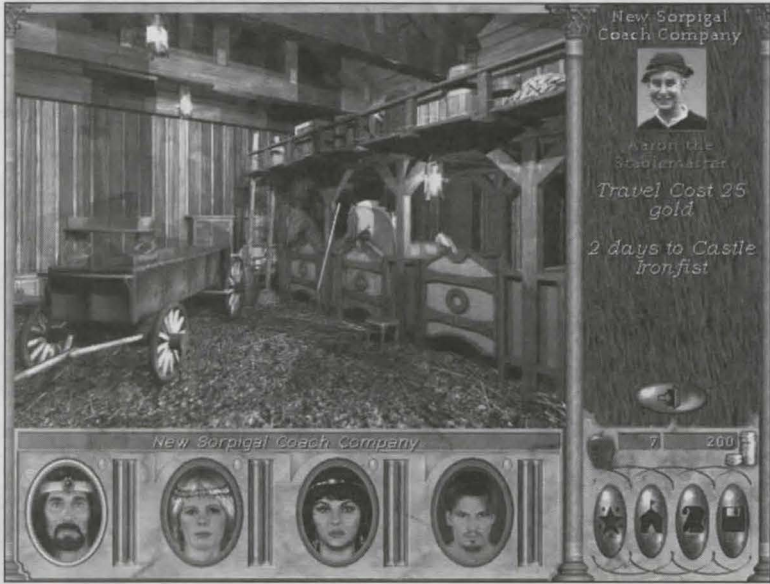

Figure 8-5 The New Sorpigal Coach Company



CHAPTER 8 Shoppes and Locations



LOCATIONS

NAME	MAP GRID	PRIMARY ITINERARY AND TRAVEL TIME	SECONDARY ITINERARY AND TRAVEL TIME	TERTIARY ITINERARY AND TRAVEL TIME
New Sorpígal Coach Company	E3	Castle Ironfist, M/W/F, 2 days	None	None
Royal Lines	D3	New Sorpígal, M/W/F, 2 days	Free Haven, Sa/Tu, 4 days	Arena S, 1 day
Free Haven Travel East	C2*	Blackshire, M/Th, 3 days	Kriegspire, Tu/F, 3 days	White Cap W/Sa, 5 days
Free Haven Travel West	C2*	Silver Cove, M/Th, 4 days	Castle Ironfist, Tu/F, 4 days	Darkmoor W/Sa, 3 days
Darkmoor Travel	C3	Free Haven, M/F, 5 days	None	None
Abdul's Discount Travel	D1*	Free Haven, M/F, 4 days	None	None
White Cap Transport Co.	C1	Free Haven, M/Th, 3 days	None	None
King's Highway	B1	Free Haven, W/Sa, 3 days	None	None
Blackshire Coach and Buggy	B2	Free Haven, Tu/F, 3 days	None	None

Stable and boat travel to Free Haven and Silver Cove is not available until those cities have been visited normally.

SHIP LINES



Figure 8-6 The Zephyr at Castle Ironfist

CHAPTER 8 Shoppes and Locations



L O C A T I O N S

NAME	MAP GRID	PRIMARY ITINERARY AND TRAVEL TIME	SECONDARY ITINERARY AND TRAVEL TIME	TERTIARY ITINERARY AND TRAVEL TIME
<i>Odyssey</i>	E3	Mist, Tu/Th/Sa, 3 days	None	None
<i>Zephyr</i>	D3	New Sorpigal, Tu/Th/Sa, 2 days	Mist, M/W/F, 2 days	Bootleg Bay, T/F, 3 days
<i>Queen Catherine</i>	D3	Volcano in E3, Su, 2 days	Volcano in B3, Su, 14 days	Hermit's Isle, everyday, 21 days
<i>Adventure</i>	E2	Castle Ironfist, M/W/F, 2 days	Silver Cove, M/Th, 3 days	Bootleg Bay, T/Th/Sa, 2 days
<i>Cerulean Skies</i>	D1*	Mist, M/Th/Sa, 3 days	Free Haven, Tu/F, 3 days	Island North W, 1 day
<i>Windrunner</i>	C2*	Mist, M/Th, 4 days	Silver Cove, Tu/F, 3 days	Castle Ironfist W, 5 days
<i>Barracuda</i>	D1: North isle*	South isle in E1, Th, 2 days	None	None
<i>Cirrus</i>	E1: South isle	North isle in E1, Sa, 1 day	None	None
<i>Tigershark</i>	E1: North isle	Silver Cove, M, 2 days	None	None
<i>Tsunami</i>	D2: Right isle	Bootleg Bay West, M/W, 1 day	None	None
<i>Valkyrie</i>	D2: Left isle	Castle Ironfist, Tu/Th, 4 days	None	None

Stable and boat travel to Free Haven and Silver Cove is not available until those cities have been visited normally.



TEMPLES

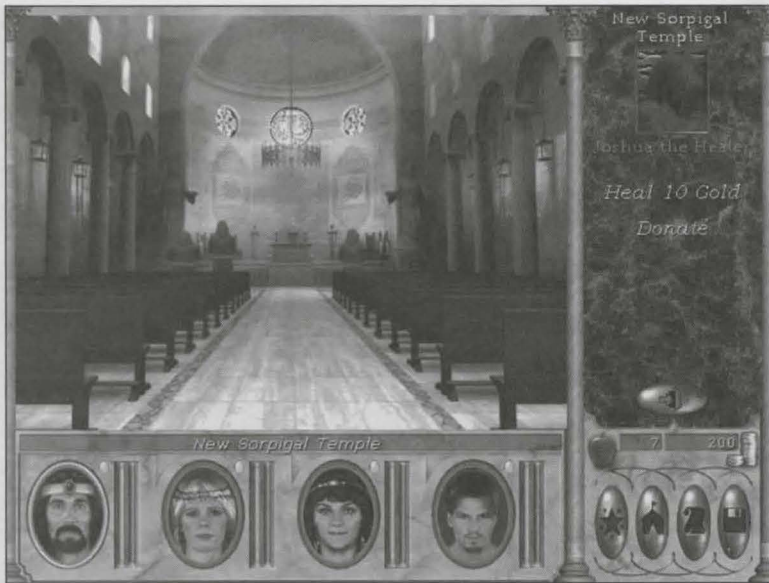

Figure 8-7 The New Sorpigal Temple

NAME	MAP GRID	LIMITS TO HEALING	SPECIAL CONSIDERATIONS
New Sorpigal Temple	E3	No Eradication	None
Free Haven Temple	C2	All OK	None
Blackshire Temple	B2	No Eradication	None
Abdul's Discount House of Worship	E1	No Eradication	None
White Cap Temple	C1	No Eradication	None
Mist Island Temple	E2	No Eradication	None
Silver Cove Temple	D1	No Eradication	None
King's Temple	D3	No Eradication	None
House of Healing	D2,C3,B1	No Eradication	None
Temple of Baa	D2,D3,C2,C3,A2,B2	No Dead, Stone, Eradication	Negative reputation for healing here

TRAINING GROUNDS



Figure 8-8 The New Sorpigal Training Grounds

NAME	MAP GRID	MAXIMUM TRAINING LEVEL
New Sorpigal Training Grounds	E3	15
Free Haven Academy	C2	60
Abdul's Discount Training Center	D1	40
The Sparring Ground	A2	No Maximum
Training-by-the-Sea	D2	20
Wolf's Den	B2	100
Royal Gymnasium	D3	200
Island Testing Center	E2	30
Lone Tree Training	B1	80
Riverside Academy	C1	50

MAGIC-USERS' GUILDS

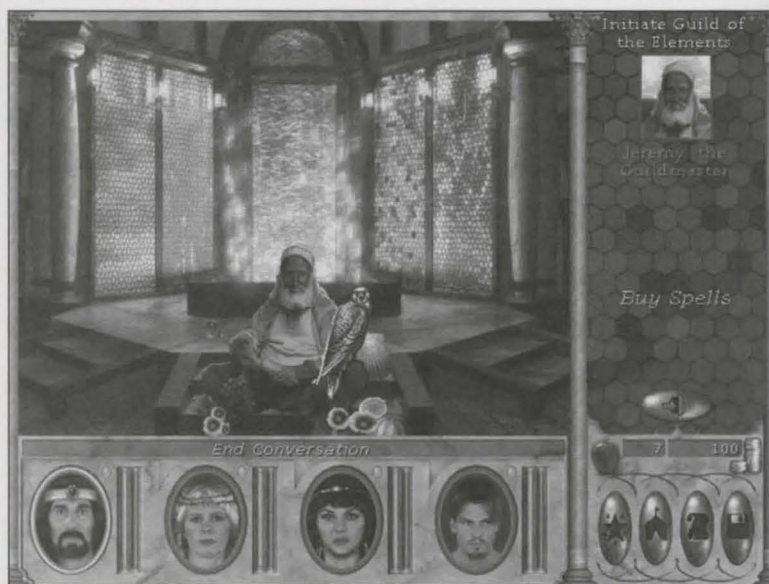

Figure 8-9 The Initiate Guild of the Elements in New Sorpigel

Name	Level	Requirements	Special
New Sorpigel Temple	E3	10 No Evaluation	None
New Sorpigel Temple	C3	10 All GPs	None
Blackstone Temple	E3	10 No Evaluation	None
White Temple of	E3	10 No Evaluation	None
White Temple	E3	10 No Evaluation	None
White Temple	C1	10 No Evaluation	None
White Temple	E2	10 No Evaluation	None
Silver Temple	D1	10 No Evaluation	None
Gold Temple	D2	10 No Evaluation	None
Temple of Healing	D1, D2, D3	10 No Evaluation	None
Temple of Healing	D1, D2, D3	10 No Eval. Stone	None
Temple of Healing	C1A-E3	Evaluation	For healing

CHAPTER 8 Shoppes and Locations



L O C A T I O N S

NAME	MAP GRID	SPELLS TAUGHT	SKILLS TAUGHT
Initiate Guild of Fire	E2	Fire, Spells 1-7	Learning, Fire
Adept Guild of Fire	C2	Fire, Spells 1-11	Learning, Fire
Initiate Guild of Air	E2	Air, Spells 1-7	Learning, Air
Adept Guild of Air	C2	Air, Spells 1-11	Learning, Air
Initiate Guild of Water	E2	Water, Spells 1-7	Learning, Water
Adept Guild of Water	C2	Water, Spells 1-11	Learning, Water
Initiate Guild of Earth	D1	Earth, Spells 1-7	Learning, Earth
Adept Guild of Earth	C2	Earth, Spells 1-11	Learning, Earth
Initiate Guild of Spirit	D3	Spirit, Spells 1-7	Meditation, Spirit
Adept Guild of Spirit	C2	Spirit, Spells 1-11	Meditation, Spirit
Initiate Guild of Mind	D3	Mind, Spells 1-7	Meditation, Mind
Adept Guild of Mind	C2	Mind, Spells 1-11	Meditation, Mind
Initiate Guild of Body	D3	Body, Spells 1-7	Meditation, Body
Adept Guild of Body	C2	Body, Spells 1-11	Meditation, Body
Initiate Guild of Light	D1	Light, Spells 1-6	Light
Adept Guild of Light	B2	Light, Spells 1-10	Light
Initiate Guild of Dark	C1	Dark, Spells 1-6	Dark
Adept Guild of Dark	B2	Dark, Spells 1-10	Dark
Initiate Guild of the Elements	E3	Fire, Air, Water, Earth, Spells 1-4	Fire, Water, Earth, Air
Adept Guild of the Elements	C1	Fire, Air, Water, Earth, Spells 1-8	Fire, Water, Earth, Air
Initiate Guild of the Self	E3	Spirit, Mind, Body, Spells 1-4	Spirit, Mind, Body
Adept Guild of the Self	D1	Spirit, Mind, Body, Spells 1-8	Spirit, Mind, Body

SKILL TRAINING CENTERS

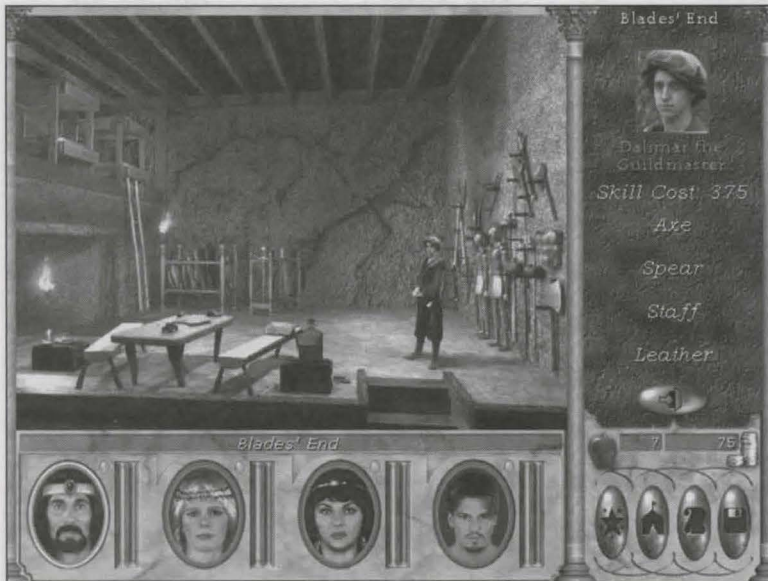
Figure 8-10 *Blades' End* in *New Sorpigal*

NAME	MAP GRID	SKILLS TAUGHT
Blades' End	E3	Sword, Axe, Spear, Staff, Leather
Duelists' Edge	E2	Mace, Bow, Chain, Shield, Body Building
Berserkers' Fury	D1	Chain, Bow, Shield, Plate, Repair Item
Duelists' Edge	C2	Mace, Bow, Chain, Shield, Body Building
Blades' End	C1	Sword, Axe, Spear, Staff, Repair Item
Berserkers' Fury	D3	Chain, Bow, Shield, Plate, Repair Item
Buccaneers' Lair	E3	Dagger, Merchant, Identify, Perception, Disarm Trap
Buccaneers' Lair	E2	Leather, Diplomacy, Identify, Perception, Disarm Trap
Protection Services	C1	Dagger, Merchant, Identify, Perception, Disarm Trap
Protection Services	D1	Leather, Diplomacy, Identify, Perception, Disarm Trap
Smugglers' Guild	C2	Dagger, Merchant, Identify, Perception, Disarm Trap
Smugglers' Guild	B2	Leather, Diplomacy, Identify, Perception, Disarm Trap



SKILL EXPERTISE AND MASTERY

These are the locations, by map, where you can learn Expertise and Mastery of your selected skills. There are two Expertise instructors per skill type, and one Mastery instructor.

SKILL NAME	EXPERT 1	EXPERT 2	MASTER
Staff	E3	E2	D1
Sword	D3	C2	B2
Axe	D3	C3	C3
Bow	C1	D3	B1
Spear	E2	D1	C3
Dagger	D3	C2	C1
Mace	C3	C1	B2
Blaster	E3	E1	A2
Fire	E3	C2	E2
Air	E3	C2	E2
Water	E3	C2	E2
Earth	E3	C2	D1
Spirit	E3	C2	D3
Mind	E3	C2	D1
Body	E3	C2	D1
Light	D1	B1	E1
Dark	C1	B2	A2
Shield	C2	D3	B2
Leather	E2	D3	C1
Chain	D2	D3	C3
Plate	D3	C2	C2
Identify Item	E3	D3	C2
Repair Item	E2	D1	C1
Merchant	C2	C3	D1
Perception	E3	D2	C3
Disarm Trap	D3	C2	C1
Body Building	E3	D3	C2
Meditation	E3	D1	E2
Learning	E3	D3	D1
Diplomacy	D3	C2	C1

TAVERNS

Have a drink here if you like, but don't overdo it. A drunk adventurer is sometimes worse than no adventurer at all.

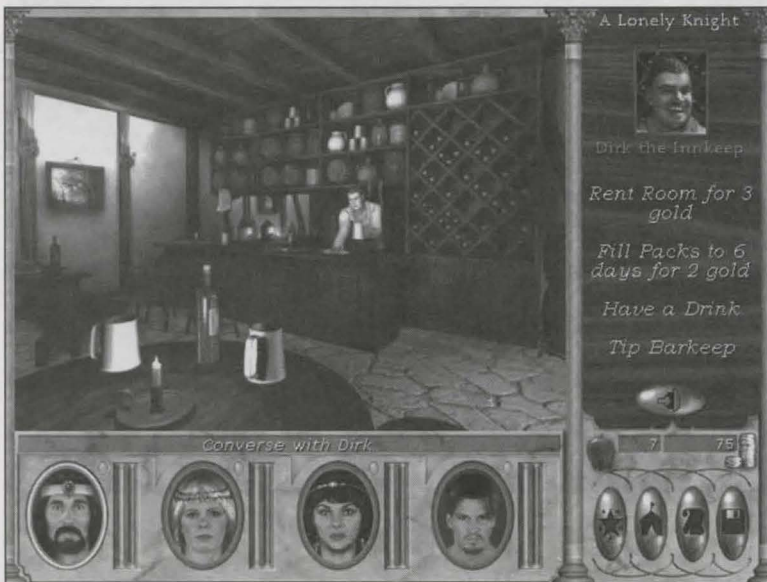

Figure 8-11 A Lonely Knight in New Sorphigal

NAME	MAP GRID	NAME	MAP GRID
A Lonely Knight	E3	The Rusted Shield	C3
The Imp Slapper	E2	Rockham's Pride	C2
An Arrow's Flight	E1	The Echoing Whisper	C2
A Stone's Throw	E1	Viktor's Hall	C2
The King's Crown	D3	Rime and Reason	C1
The Will o' the Wisp	D3	The Frosty Tankard	C1
The Goblin's Tooth	D2	The Oasis	B2
The Broken Cutlass	D2	The Howling Moon	B2
Anchors Away	D1	The Broken Promise	B1
The Grove	D1	The Last Chance	A2
The Haunt	C3		

BANKS

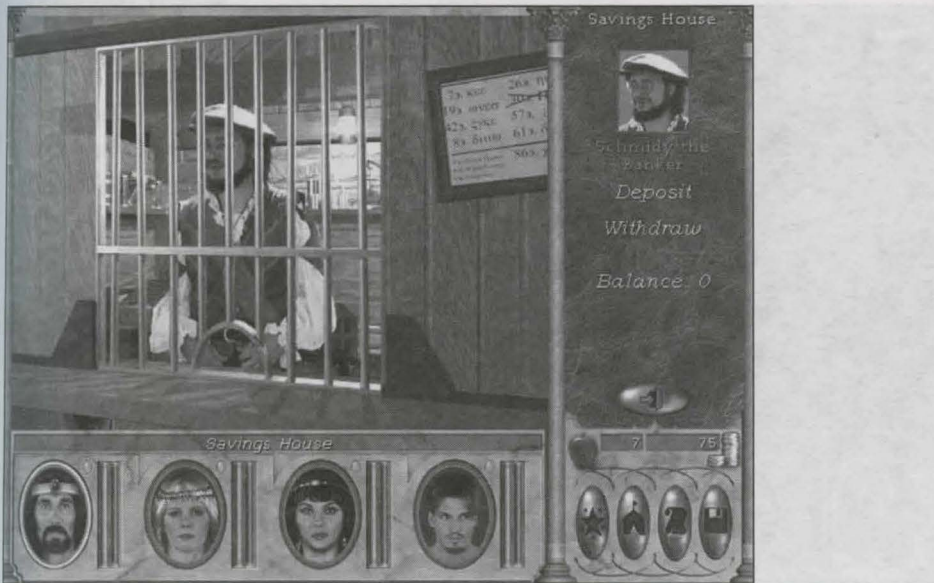

Figure 8-12 The Savings House in New Sorspigel

NAME	MAP GRID
Savings House	E3
The Reserves	E2
The First Bank of Enroth	D1
Foreign Exchange	C2
Secure Trust	C1
The Depository	B2

DUNGEONS

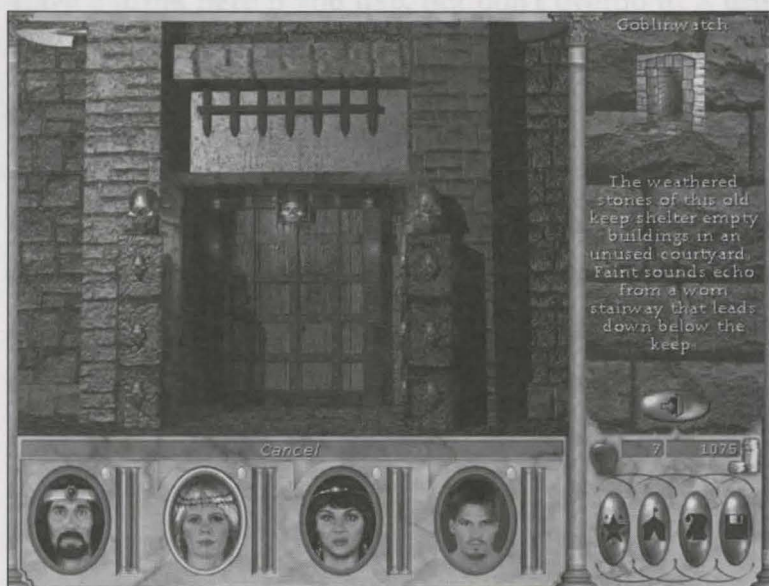
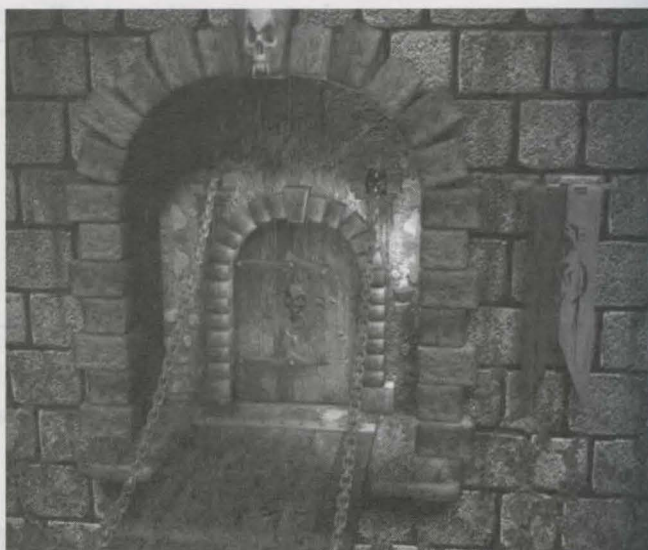

Figure 8-13 *Goblinwatch, Just Outside New Sorpigal*



CHAPTER 8 Shoppes and Locations



L O C A T I O N S

NAME	MAP GRID
Goblinwatch	E3
Abandoned Temple	E3
Shadow Guild Hideout	D3
Hall of the Fire Lord	D2
Snergle's Caverns	D3
Dragoons' Caverns	D3
Silver Helm Outpost	E2
Shadow Guild	C1
Snergle's Iron Mines	C3
Dragoons' Keep	C2
Corlagon's Estate	D3
Silver Helm Stronghold	D1
The Monolith	D1
Tomb of Ethric the Mad	C2
Icewind Keep	C1
Warlord's Fortress	D1
Lair of the Wolf	B2
Gharik's Forge	E3
Agar's Laboratory	B1
Caves of the Dragon Riders	B1
Temple of Baa	D3
Temple of the Fist	D2
Temple of Tsantsa	D2
Temple of the Sun	D2
Temple of the Moon	C2
Supreme Temple of Baa	A3
Superior Temple of Baa	B1
Temple of the Snake	B2
Castle Alamos	E1
Castle Darkmoor	C3
Castle Kriegspire	B1
Tomb of VARN	B3
The Hive	A1

CASTLE LOCATIONS



Figure 8-14 Castle Ironfist

NAME	MAP GRID
Castle Ironfist	D3
Castle Newton	E2
Castle Temper	C2
Castle Stone	C1, R
Castle Fleise	D1
Castle Stromgard	C1
Castle Darkmoor	C3
Castle Kriegspire	B1
Castle Alamos	E1

CHAPTER 8 Shoppes and Locations



L O C A T I O N S

The game features more than 300 houses you can enter, as well. Inside you'll find quests, information, guild memberships, and so on. Likewise, there are tents and wagons with like objectives, although these number far fewer.







CHAPTER 9

Essential Quests



The *Mandate of Heaven* is primarily concerned with quest-based adventuring. Any walkthrough, then, must focus on quests that will get the player from the opening titles to the end credits in the shortest time. This section of the book comprises three chapters—essential quests, important quests, and side quests. Essential quests, which we explore in this chapter, are the quests you must perform to progress through the game to the end. Important quests (Chapter 10) are quests you *ought to* perform; they'll help your characters in their adventuring (and thus enhance your gaming experience). Side quests (Chapter 11) gain you minor riches and rewards. They're generally of the “go get an item, return it to me, and I'll give you so much gold” variety. Most side quests occur within the map boundaries of the area where you took on the quest, but a few will make you do a little traveling.

This chapter focuses solely on quests you must complete to finish the game. It includes descriptions of areas you must pass through (town, castle, and dungeon names and locations, for example) and locations of quest items. Appendix A's map section allows you to cross-reference item locations and tells you which monsters you can expect to encounter on each map.

Note that for the essential and important quests, at least, you'll be doing a lot of traveling. Despite the way the quests are written up, try



to avoid attempting to complete them in a linear fashion. For instance, the first essential quest (the High Council quest) takes you through areas low-level characters would be wise to avoid. New Sorpígal and Castle Ironfist (your first two maps) are stuffed with relatively easy quests. Take your time. Enjoy the journey. And train, train, train!

THE HIGH COUNCIL QUEST

You begin just outside the town of New Sorpígal, on Map E3, carrying enough adventuring equipment to start on the road to becoming saviors of the land, so equip yourself. You also carry the Letter, which you must take to Andover Potbello in the New Sorpígal tavern. Easy enough: Walk through the town gate and enter the first building on the right. Your reward is 1000 gold, with which you can obtain some better equipment than the stuff you're carrying. Sure, this gold is Judas money, but consider it the first step toward saving the world. Oddly, Potbello doesn't take the Letter from you. It forms the basis of the first essential quest; to begin, you must first take the Letter to Regent Wilbur Humphrey at Castle Ironfist on Map D3.

To get there, head west along the road that runs past New Sorpígal. Eventually you'll come to the edge of Map E3 and will cross into Map D3. Make sure you have plenty of food! On map D3, head north at the first crossroad, which leads to Castle Ironfist. On the hill above the town is the castle entrance. Go inside and converse with Wilbur Humphrey, who will give you gold (and some experience) in exchange for the Letter.

After you give the Letter to Wilbur Humphrey, he offers you the first of the subquests that make up the High Council quest. You must play through six subquests to solve the High Council quest; you receive each from a local lord with a representative on the High Council. The High Council itself is in the town of Free Haven (Map C2), and you can enter High Council chambers at

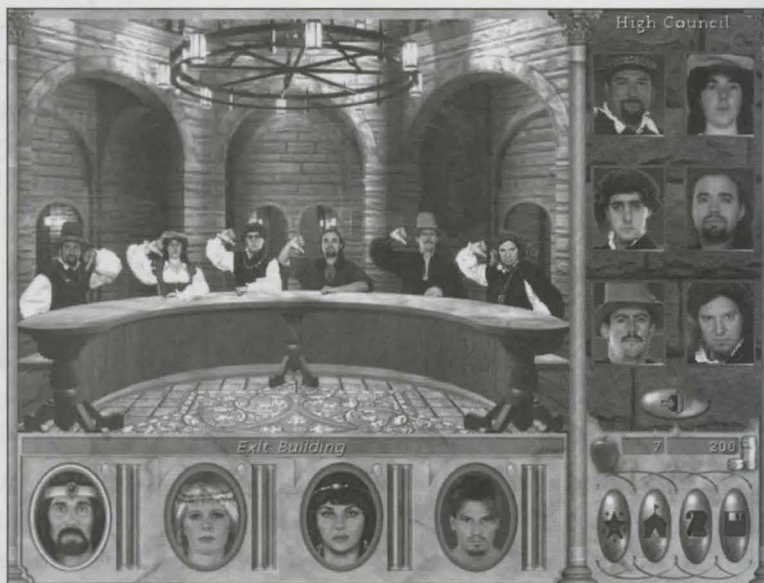

Figure 9-1 *The High Council doesn't think much of you just yet.*

any time to check on the progress of each subquest. After you complete a subquest, the appropriate representative will change his vote from thumbs-down to thumbs-up. You can perform the subquests in the order most convenient for you.

If you speak to Prince Nicolai at any time during your stay at Castle Ironfist, you immediately receive the Find Nicolai quest. This, too, is an essential quest, but of a far more insubstantial nature.

High Council Quest Subquest A: Wilbur Humphrey

Wilbur Humphrey would like you to find Lord Kilburn's shield and return it to him. It lies in a chest south of the town of Blackshire (Map B2), almost directly east of the Lair of the Wolf dungeon. The chest is heavily warded and trapped, so your skill in Disarm Traps must be high (base level at least 9, preferably Expert or better in the



Figure 9-2 Castle Ironfist, where you get your first subquest

Disarm Traps skill). Retrieve the shield and return with it to Castle Ironfist. Note that Slicker Silvertongue, Regent Humphrey’s representative on the High Council, doesn’t give you a “thumbs up” vote. (See the Find the Traitor quest.)

High Council Quest Subquest B: Albert Newton

In the Misty Islands (Map E2), the absentminded high sorcerer of Enroth Albert Newton wants you to recover the Hourglass of Time for him. He has trouble recollecting all he’s learned in the course of his life. Using the Hourglass of Time he can create a mirror that will allow him to look back in time and make copious notes. He tells you the Hourglass lies in a fort south of Castle Newton—but, really, do you think you can trust his memory on this?



Figure 9-3 *Castle Newton*

In fact, you can. Albert Newton may be absentminded about minor things, but when it comes to priceless artifacts such as the Hourglass of Time, his memory is dead-on. Go to the Silver Helm Outpost (conveniently located in the Misty Islands, just southeast of Castle Newton). Enter the Silver Helm Outpost and descend the ramp; then enter the mess hall and go through the second door on your left. Proceed to the back of this area (you'll pass through several rooms and a door), where you'll find a switch on one of the walls. It opens a secret door in this room's antechamber. Go through the secret door. In the chamber beyond, the chest on the right wall contains a small key—the Key to Gharik's Laboratory. Exit the Silver Helm Outpost and go to Gharik's Forge, on an island near New Sorpigal.

Inside Gharik's Forge, head down the spiraling ramp. At its end lies a room with a lava pit and no apparent way to cross it. Look carefully at the left wall of this room, though, and you'll discover a secret



door. Beyond lies a room with a lever that extends a bridge across the lava pit. Cross the bridge, pull the lever at the end of the hall, and go through the door. Head through the first door on your right, and you'll find yourself in the "bridge-and-lever" area.

Your objective in the bridge-and-lever area is to open the proper doors and move the bridge so you can get to the hallway leading to Gharik's Laboratory. We'll number the levers on the top floor T1 through T4 and the levers on the bottom B1 through B4. (Refer to the map of Gharik's Forge to see which lever number is which.) The sequence for solving this puzzle is T1, B3, B4 (moves bridge), B1.

Cross the bridge after you've moved it, and then continue down the hallway to its terminus. Go through the door there, and then through the door on the right wall of that room. At the end of the hallway is a small "roundabout"; you're interested in the door on the left wall. Go through it, open the next door, enter the small room, and then turn around and throw the lever there. You'll descend in an elevator and come to another lava area. Cross the bridge and go through the door on the far side of the room. Follow the corridors until, at last, you find yourself in Gharik's Laboratory. The Hourglass of Time lies in the chest in front of you. Leave Gharik's Forge through the exit marked on the map and return the Hourglass of Time to Lord Newton.

High Council Quest Subquest C: Loretta Fleise

Loretta Fleise is one of the land's *nouveau riche*, and is deeply interested in lining her pockets with as much of other peoples' money as she can get her hands on. She tasks you to visit all nine Stables and fix their prices for her. Castle Fleise is located on Map D1. After she gives you this quest, a "Fix Prices" option appears at each Stable. This subquest can take awhile to complete, but, if you do so in fewer than 30 days, the reward is substantial:
25,000 GP.

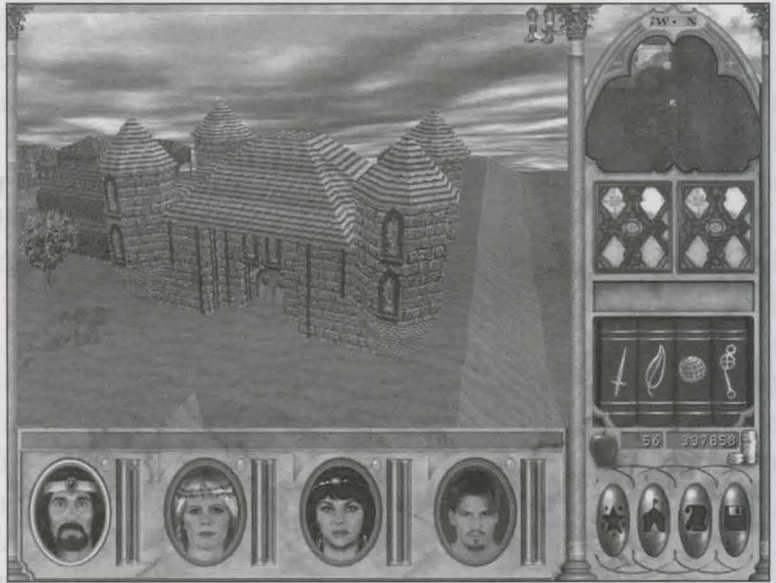

Figure 9-4 *Castle Fleise*

To complete this subquest in under 30 days, you'll need magic; specifically, you'll need the Town Portal spell, or, if you're having truly amazing luck, Lloyd's Beacon. If you have neither, then take your sweet time with it. The unfortunate thing about taking on this subquest without magical assistance is that you'll need a lot of money to complete it. Perform this subquest in any order. (Refer to Chapter 8 for Stable locations.)

High Council Quest Subquest D: Anthony Stone

Anthony Stone's "business" in Enroth is overseeing the less savory side of things from his castle in the Frozen Highlands (Map B1). In other words, he keeps the numerous common street thugs from running amok within the environs of King Roland's domain. A man who

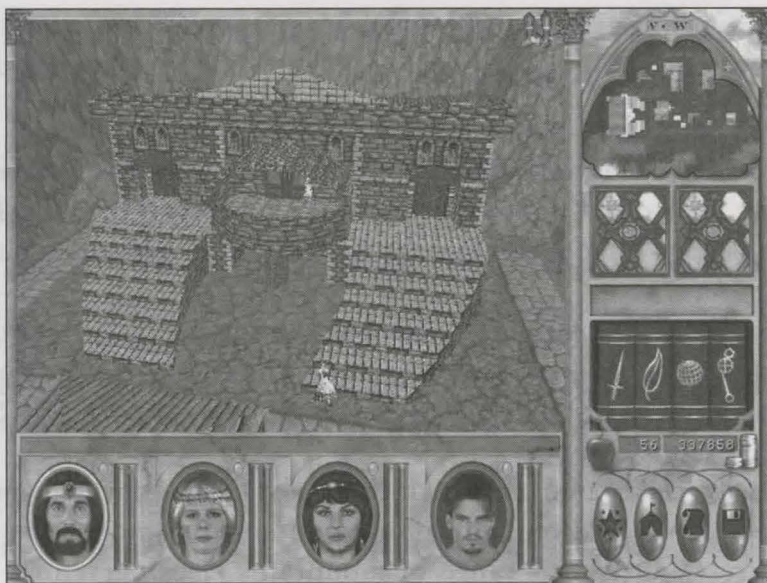

Figure 9-5 Castle Stonel

calls himself the “Prince of Thieves” recently has appeared in Enroth and is usurping Lord Stone’s authority over the guilds. Lord Stone wants this man brought back in chains, for which he will give you his support in the High Council, as well as some money.

Unfortunately, Lord Stone has no idea where the man might be hiding, although he mentions the town of Free Haven. Good guess; the Prince of Thieves is indeed very near Free Haven: He’s hiding in the sewers.

There are a number of sewer entrances in Free Haven, so if you just go about poking your nose into peoples’ houses you’ll eventually find an entrance. From wherever you enter the sewers, make your way to the far west end of the map. You’ll find you can freely walk into a secret room on the west wall of the last room; click on it, walk in, click on the bed you’ll find there, and then return to Castle Stone.

High Council Quest Subquest E: Erik Von Stromgard

Lord Von Stromgard (Map C1) has a strange sense of humor. Somehow he's gotten it into his head that you can control the weather, and he wants you to put a stop to this whole business of winter. Frozen Highlands hasn't had a summer for several years, and he's a bit upset about it.

This seems an insurmountable task, given what little information you have on the subject of winter in the Frozen Highlands. However, your party has the standing of gods in the eyes of Lord Von Stromgard, so you must comply.

Actually, this is one of the game's easiest tasks, provided you have the "Fly" spell and can take on some serious monsters. Go to Kriegspire (Map B1). A range of mountains rises very high in the map's central area. Atop this range lives the Hermit on the Mountain.



Figure 9-6 *Castle Stromgard*



Talk to him, and then return to Castle Stromgard and speak to Lord Von Stromgard.

High Council Quest Subquest 5: Osric Temper

Osric Temper built his castle in the wasteland south of Free Haven (Map C2), a central location for a man who fashions himself the protector of the kingdom. His task for you seems to be one of the hardest: Go to Kriegspire, invade the demons' outpost, slay all the demons, and then return with any information you can about the demons' plans. It's all very straightforward, and you're almost certain to die horrible deaths at least once along the way.

Make sure your party is completely beefy. The Devil Outpost is full of demons, and they hit very, very hard. The saving grace to

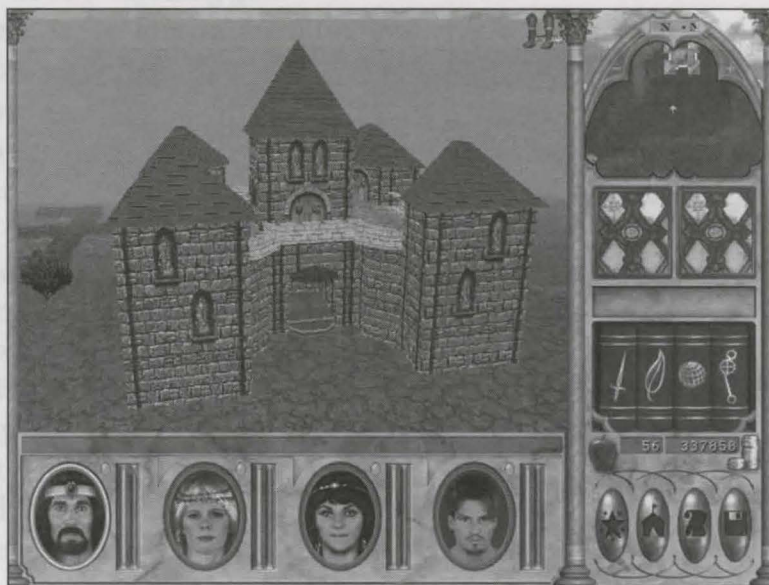

Figure 9-7 Castle Temper

cleaning out this outpost is that the entire place consists of a single room. It's the monsters you must battle along the way that present the biggest obstacles to this subquest, though, because the Devil Outpost lies just north of Castle Kriegspire on Map B1.

After you make it to the outpost, simply walk in, kill everything in sight, pick up the plans from the floor in front of the ominous pentagram, and then exit the lair. Return with the plans to Castle Temper.

FIND NICOLAI

If you spoke to Prince Nicolai at Castle Ironfist, he manages to get out of the castle and join your party. There's nothing you can do about this. After he joins your party, he disappears from it the first time you stop to rest. Again, there's nothing you can do about it. His fascination with the Circus is your only clue to his whereabouts, and, indeed, that's exactly what he's done: He's run off to join the Circus.

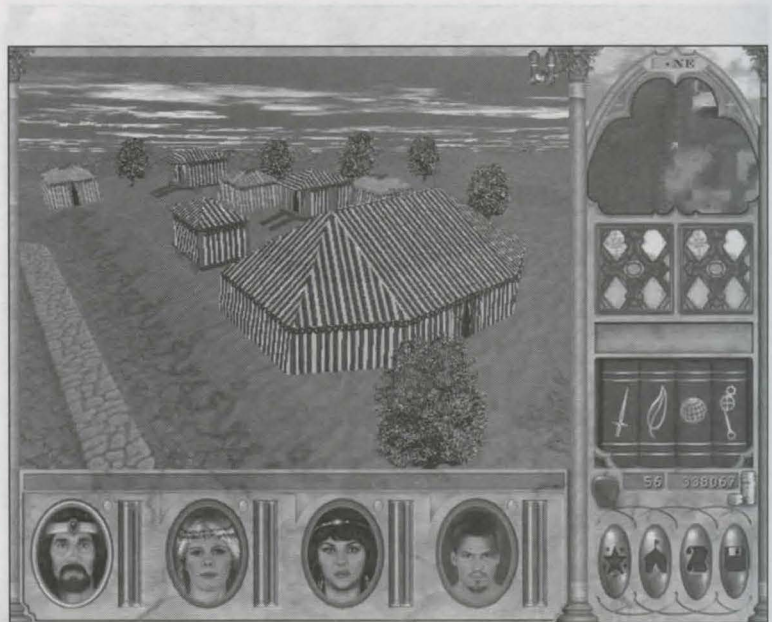

Figure 9-8 *The Circus moves around a bit!*



The problem with finding him is that the Circus moves around, and it only tours a few months of the year.

TABLE 9-1 Timetable for the Circus

LOCATION	TIME
Blackshire	March 28 – April 27
Bootleg Bay	November 28 – December 27
Mire of the Damned	July 28 – August 27

TRAITOR QUEST

If you completed the High Council Quest, Slicker Silvertongue's thumbs-down may baffle you. You guessed it. You must find a way to expose him, a way to link him with the Temple of Baa!

You need a smoking gun.

There is, in fact, a smoking gun. It's a letter (the Letter from Zenofex), and you'll find it in the Superior Temple of Baa (Map B1). You can't enter this temple without Baa cloaks, but they're relatively easy to get. Go talk to Wilbur Humphrey at Castle Ironfist and he'll give you a Baa cloak. Wear it to gain entrance to the Superior Temple of Baa.

When you enter the Temple, go across the great hall and through the door on the opposite side. Go left at the intersection, and then take your first right. Follow this hall to a door at the end. Beyond it waits the High Priest of Baa. Kill him to get the High Priest's Key. Exit the way you entered, and then retrace your steps to the great hall. Enter the door in the western end of the south wall and continue down the corridor to a T intersection. Turn right and follow this hall to its end. The High Magician of Baa waits in the last room; he, too, gives up a key after you've killed him. Head back to the great hall and go through the door



Figure 9-9 The traitor flees.

direct in the middle of the west wall. Take a left at the T intersection, and then turn down the first side corridor on your left. This hallway leads into a room where you'll find a chest on a table. The party member who attempts to open it should have both keys in his inventory. The Letter from Zenofex lies inside the chest. Exit the temple, take the letter to the High Council, and talk to Slicker Silvertongue about admission to the Oracle. He flees, and you may enter the Oracle's chambers.

Take a moment before you do to visit Wilbur Humphrey in Castle Ironfist. He thanks you profusely and, better, he offers you full use of the royal yacht—the *Queen Catherine*, anchored in the harbor below Castle Ironfist. You'll need it to get to the Supreme Temple of Baa on Hermit's Isle.



ORACLE QUEST

After you've completed the High Council quest and the Traitor quest, the High Council grants you admission to the Oracle, located in the basement of the High Council building. Enter the Oracle area and talk to the Oracle. It tells you that, to proceed, it needs memory crystals Alpha, Beta, Delta, and Epsilon. Because they're located in different places, I'll treat them as subquests. You need perform these subquests no particular order.

Oracle Quest Subquest A: Memory Crystal Alpha

Take the *Queen Catherine* to Hermit's Isle (Map A3) and enter the Supreme Temple of Baa. Follow this hallway through the amphithe-

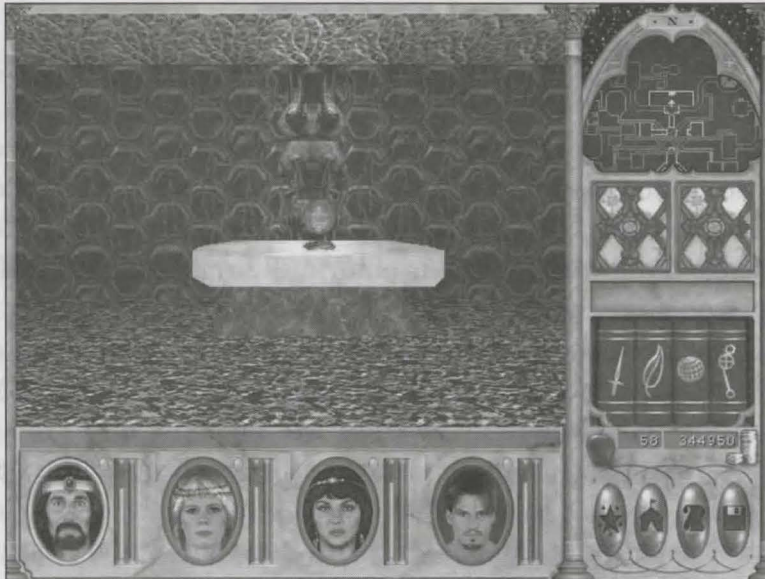
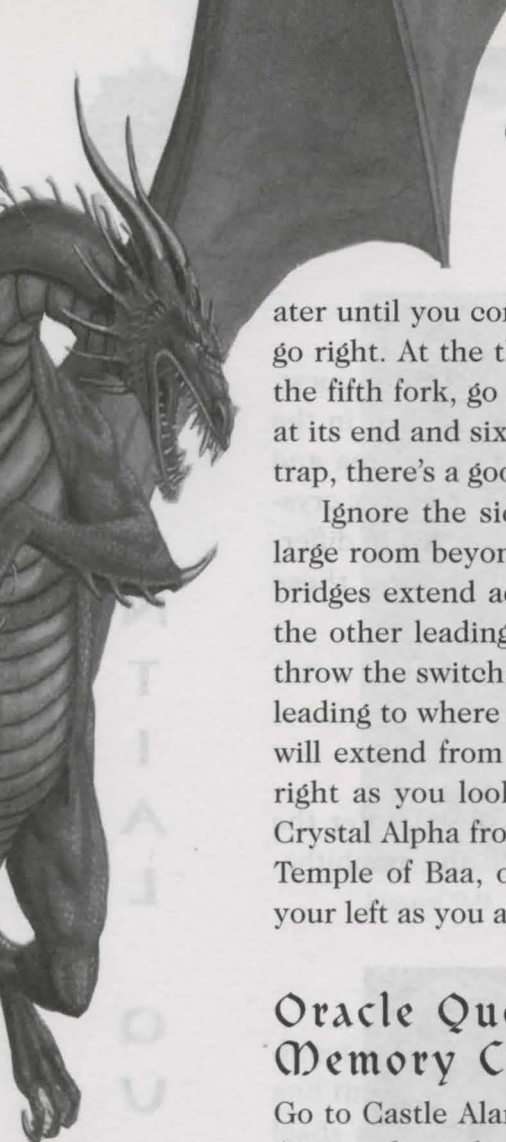

Figure 9-10 *Memory Crystal Alpha's Location*



ater until you come to a fork. Take the left corridor. At the next fork go right. At the third fork, go left, and at the fourth fork, go right. At the fifth fork, go right again. You'll enter a larger hall with a doorway at its end and six halls branching off from its sides. If this looks like a trap, there's a good reason!

Ignore the side passages and approach the doorway ahead. The large room beyond holds a pillar with a sheer drop all around it. Two bridges extend across the gap to the pillar—one in front of you and the other leading to a room on the right. Cross the two bridges and throw the switch in the doorway of the room on the right. The bridge leading to where you entered this room will retract, and a new bridge will extend from the wall on the opposite side of the room (to your right as you look at it). Cross this new bridge to retrieve Memory Crystal Alpha from its holder. Retrace your steps to exit the Supreme Temple of Baa, or exit through the teleporter just down the hall to your left as you approach the main entrance.

Oracle Quest Subquest B: Memory Crystal Beta

Go to Castle Alamos (Map E1) and turn left at the first intersection. As you do, a doorway appears to your left. Ignore it and follow the hall as it turns gently to the right. At the end, take care not to step off the ledge. Follow the ledge around to the right and enter the first doorway you find there. At the next intersection, turn left. Follow this hall down to the large room at its end and turn right as you enter. Move along the right-hand wall and enter the doorway. Make a U-turn to the right, where an elevator will take you up to the room's upper level. Exit left off the elevator and pass through the doorway ahead. Again, try not to fall off the ledge. Turn right and follow the ledge across the room. At the end, you must know the password to enter the next hallway: JBARD. (To acquire this password legitimately, find the trees in the castle that hold the clues.) Follow the



Figure 9-11 *Memory Crystal Beta's Location*

hallway to its end, where you'll find Memory Crystal Beta. Retrace your steps to exit the castle.

Oracle Quest Subquest C: Memory Crystal Delta

Go to Castle Darkmoor (Map C3). Take care in this castle: It holds numerous traps. At the first set of stairs you come to, turn left. At the next set of stairs, turn left again. Cross the next room, and then turn right and ascend the stairs. You emerge in a large room with two other entrances, one left and one right. Go through the door to your right. Continue to the top of the ramp ahead. Turn right in the room at the top, but watch out for the trap in the room you enter (stay near the walls and you won't set it off).

Go down the hallway ahead. At the end,



Figure 9-12 Memory Crystal Delta's Location

around a short left turn, is a sign. Click on it to open a wall panel. Throw the switch there, and then return to the large room just beyond the bottom of the ramp.

This time, go through the door that lay to your left as you entered this room. At the top of the ramp there, turn left. You should see a red cube hanging in midair in the large room you're about to enter. Run to a point just below the red cube, and then click on the cube. This opens a door on the far side of the room almost directly in front of you.

Go through the now-open doorway and head left to a ramp leading up the side of the building you're currently traveling around. Go up the ramp and press the wall there to open a secret door. Enter the room beyond, and then go through the left doorway. Continue following the hall until you come to a window overlooking a large room below. On the far side of the room is another cube. Cast Feather Fall, and then jump into the room below. Head straight for the cube, and



then turn left as you get under it. At the end of this short hall is Memory Crystal Delta. Grab it, and then head back to the cube. Click on the sign next to the cube and the cube will turn red. Stand under the cube and click on the cube itself. This transports you to a new location, where you'll find a podium with a book on it (*The Book of Liches*). If you click on the book, you'll destroy it. This is part of another quest you can pick up later.

Click on the teleporter wall in this room to transport to a new location. Head down the hall in the only direction you can go. When you reach the first intersection, make a U-turn to the left. Follow the hallway to its end and go up the ramp. Go through the door at the top of the ramp and you'll find yourself back in the room with the first red cube. Head to the far corner of the room from the doorway you entered through. You're in familiar territory, now, so find your way to the exit.

Oracle Quest Subquest D: Memory Crystal Epsilon

Go to Castle Kriegspire (Map B1). Enter its first room; then exit the room to the east. Turn right, and then go left down the narrow hallway. Turn left at the end, and then take the first right. Go down this hallway, clearing out the four interconnected rooms at the end. Between the two easternmost rooms of this area lies a small east-west corridor. Go east down this hallway and open the door at the end. Turn right and continue around to some stairs. At the top of the stairs, you'll find yourself on a ledge overlooking the four rooms you just cleared. Proceed to your right around the ledge, enter the first doorway on your right, and then follow the ledge around toward the left. Enter the first doorway on your left, and then turn left along the ledge again. The first doorway on your left leads into a small, circular room. Throw the small switch on the pillar here, and then go back to the hallway from

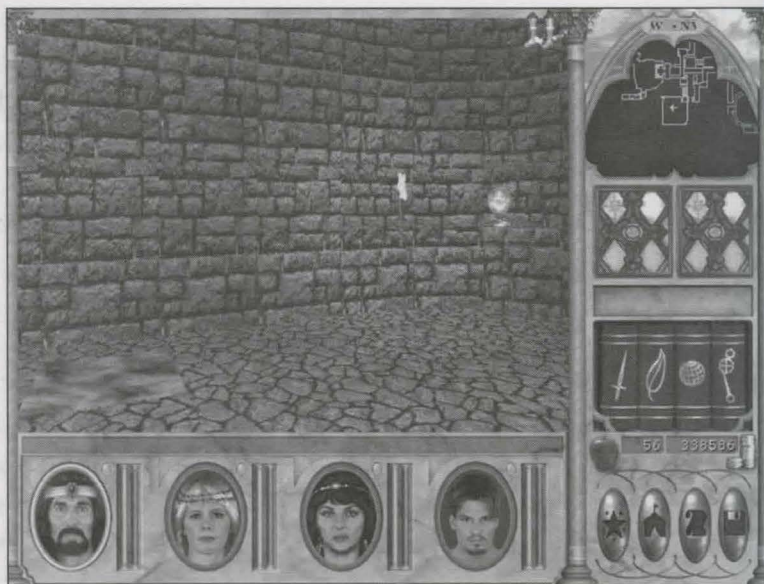

Figure 9-13 *Memory Crystal Epsilon's Location*

which you entered the four interconnected rooms (it's easiest to cast Feather Fall, and then jump off the ledge).

Once you're back in the hallway, head back the way you came, but turn down the first left-hand corridor you come to. The barred door in front of you opens. Go through it and follow the hallway around. At the top of the stairs, you can see Memory Crystal Epsilon in the room ahead. Jump down into the room and retrieve the crystal, and then walk onto the teleport pad on the floor next to the crystal. You'll emerge at the base of the stairs where you jumped into the room. Go through the door immediately ahead and on through the door beyond. You'll find yourself back in an area very near the castle entrance.

Exit Castle Kriegspire.

Place the memory crystals on the four altars in the Oracle's chambers in any order. Go speak to the Oracle again, and it will give you



information concerning the demons, most notably about their weakness to attacks from particular weapons. These weapons (the Blasters) are located within the planetary Control Center, but you need something called a Control Cube to get into this area. The Control Cube lies in the Tomb of Varn—which brings you to your next quest.

TOMB OF VARN QUEST

If you've been to Dragonsand (Map B3) already, you're either incredibly high in levels, or amazingly foolhardy. Dragonsand is one of the game's toughest locations. It also holds the game's biggest dungeon, the Tomb of Varn—the large Pyramid that occupies part of the map in the northern half of Dragonsand. You don't need anything in particular to enter the Pyramid.

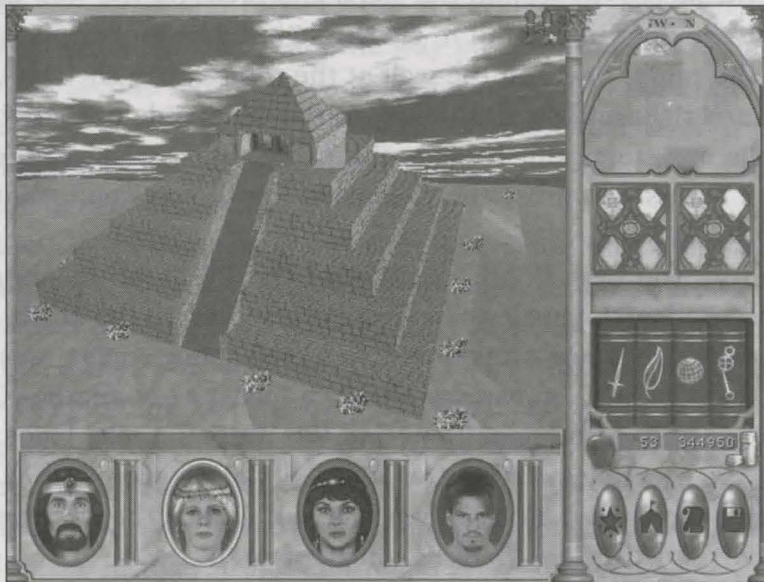
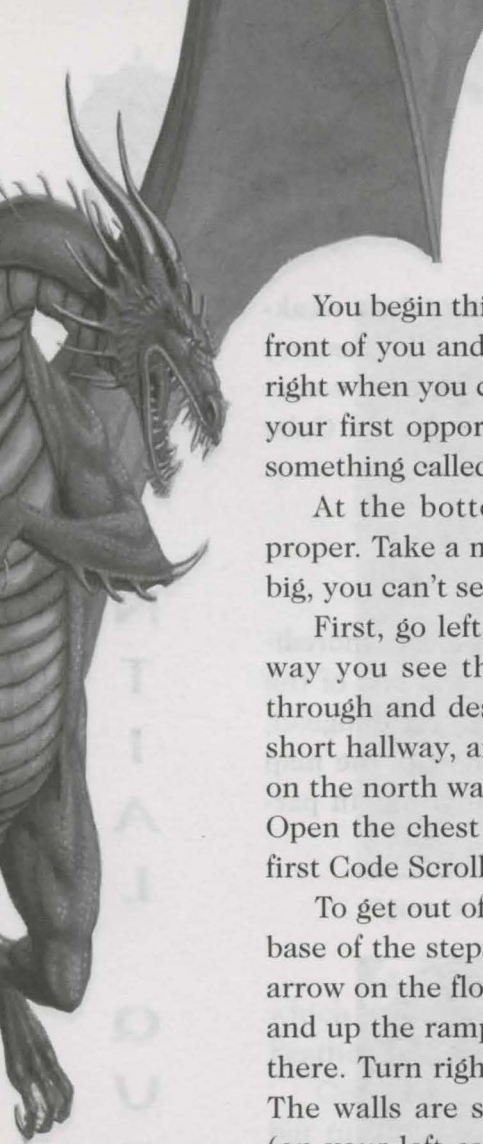

Figure 9-14 *The Tomb of Varn awaits you!*



You begin this quest in a very small room. Open the picture door in front of you and prepare to do battle with the monsters of Varn. Turn right when you can go forward no farther, and go left down the ramp at your first opportunity. Just down the ramp a Sentinel of Varn holds something called the Back Door Key. Pick it up and keep moving.

At the bottom of the ramp lies the entrance to the Pyramid proper. Take a moment to marvel at the sheer size of the place. It's so big, you can't see clearly from one end of it to the other.

First, go left, across the Cleansing Pool, and cut across the walkway you see there. On the left wall is another picture door. Go through and descend the steps to the door. Open it, walk down the short hallway, and enter the room at the end. Press the switch button on the north wall and a secret wall panel slides back directly above it. Open the chest you find there and retrieve the Flame Door Key, the first Code Scroll, and the Crystal Skull.

To get out of this area, exit the room and turn to your right at the base of the steps. Go around the steps and press on the wall with the arrow on the floor in front of it. Go through the now-open secret door and up the ramp; press on the wall at the top to open the secret door there. Turn right and go all the way to the other side of the Pyramid. The walls are steep, but they're climbable. Bypass the Flame Door (on your left as you cross the Cleansing Pool); you don't want to go through it just yet.

Head up the first sloping section of the Pyramid, heading east-northeast. Follow the huge wall in front of you toward the north. Ignore the doorway you'll pass on your left and keep going, angling west a bit, toward the doorway you can see ahead. It leads to yet another Cleansing Pool, as well as the Back Door and the Water Temple. Once you're through the doorway into this area, head all the way across the Cleansing Pool to the Back Door, solidly positioned against the west wall. The person carrying the Back Door Key must open the door.

Follow this corridor around to the fifth intersection, and then



turn right. In the distance, you should be able to see a stairway spiraling upward. Pass to the right of the stairs, stopping short of the open pit (see the Pyramid Top 2 map). Take a running jump and you should be able to clear the pit (but cast Feather Fall on your party just in case you can't). If you make it across, follow the hallway into a large, squarish room and then step off the ledge in front of you (you did cast Feather Fall, didn't you?). Head for the door in the south corner. When you come to a room with yet another Cleansing Pool, go straight across it.

At the next intersection, turn right and follow the hallway around. Turn right at the T intersection, take your first right, and run to the end of it. This drops you down into a left-right corridor; go right. At the first intersection in this lower area, go left and continue along the hallway to the first opening on the right. Pass through it into the room beyond. The wall ahead has an opening along its right-hand side, so go around it and find the chest behind it.

Open the chest and retrieve the Water Temple Key and the second Code Scroll. Exit the room the way you entered and retrace your path to the second left. This leads up a ramp; stay to the right in this passage, until you're past the open pit on the left. Follow your path back to the spiraling stairs and remember to jump over the open pit at the top of the squarish room.

Follow the hallway back out the Back Door, and then cross the Cleansing Pool toward the doorway through which you entered the area. Instead of going back through it, though, turn left and go to the top of the ramp. The door at the top leads into the Water Temple; open it and take the first right-hand passageway. At the bottom of this passage lies another chest; open it to retrieve the Bibliotheca Chest Key, the third Code Scroll, and the second Crystal Skull. Exit the Water Temple the way you came in, and head for the Back Door again.

Follow the hallway around until you get to the first open area, where a hallway leads into a large room off to the right.

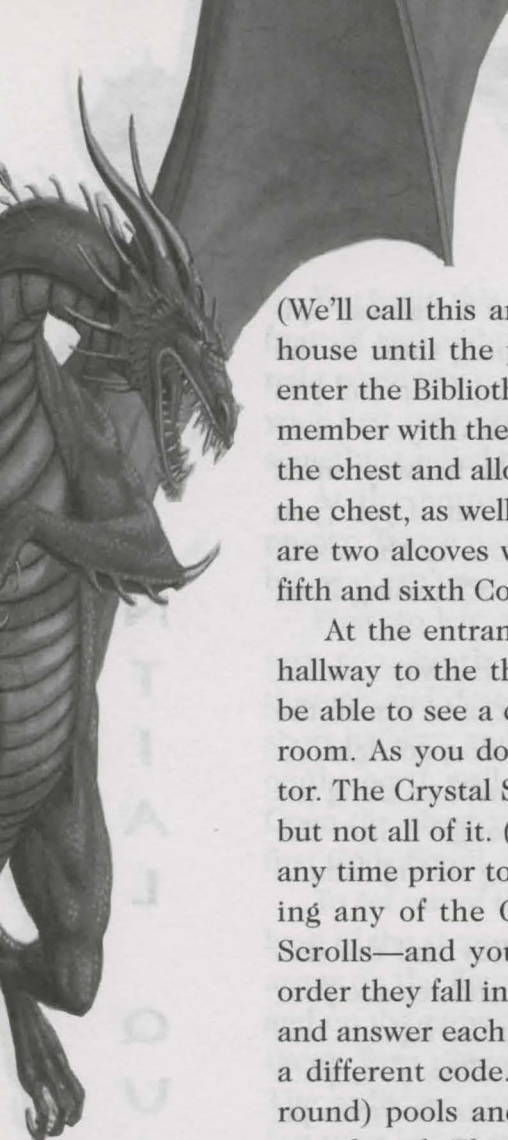

(We'll call this area the Bathhouse.) Pass straight through the Bathhouse until the passage angles left; turn left and then left again to enter the Bibliotheca. At the far end of the room is a chest; the party member with the highest Disarm Traps skill should be given the key to the chest and allowed to open it. Retrieve the fourth Code Scroll from the chest, as well as the Varn's Chest Key. On either side of the chest are two alcoves with three statues. Check on each alcove to find the fifth and sixth Code Scrolls. Exit back through the Bathhouse.

At the entrance to the Bathhouse area, turn right and follow the hallway to the third intersection. Turn right. From here you should be able to see a column in the middle of a large room. Head into the room. As you do, you take damage from the Pyramid's leaking reactor. The Crystal Skulls you carry should mitigate some of the damage, but not all of it. (By the way, if you entered this room accidentally at any time prior to this, you can protect yourself temporarily by entering any of the Cleansing Pools outside.) If you've read the Code Scrolls—and you should have, by now—you'll already know what order they fall in. Enter any pool in this room, except the round one, and answer each question put to you. Each pool requires you to input a different code. Once you've gone through each of the five (non-round) pools and answered the questions accurately, step into the round pool. This is the entrance to the Well of Varn, and it will ask you to name the sixth code.

The codes you need are organized by rank:

First Mate's Code:	KCOPS
Navigator's Code:	ULUS
Communication Officer's Code:	ARUHU
Engineer's Code:	YTTOCS
Doctor's Code:	YOCCM
Captain's Code:	KRIK



Learn them before you start taking damage from the leaking Reactor Core.

Cast Feather Fall immediately after answering the Well of Varn question; if you're not already falling, step through the now-open trapdoor in the center of the Well. This drops you into the Well of Varn proper, an octagonal room with two passages leading northwest and southeast. Click on the northwest barrier to enter the Pyramid control area. At the back of this room lies Varn's Chest; open it to retrieve the Control Cube. Exit the area by passing through the Well of Varn toward the southeast; you'll find yourself back in the area where you got the Water Temple Key. Follow the path out, and then cut across the middle of the Pyramid (where you answered the six questions) and open the Flame Door on the opposite side. Exit the Tomb of Varn the way you entered it (you'll need a substantial Might statistic to open the door).

If you'd rather exit another way, turn left as you come through the Flame Door and follow the Pyramid wall as though you were heading back to the doorway to the Water Temple/Back Door area. Instead of going there, though, enter the doorway on your left that you passed by your first time through. Follow the hallway to its terminus and press the switch there. An elevator will take you to the top of the Pyramid, where you'll find a door. (If you find yourself in this room through sheer curiosity and don't want to fall to your death, the elevator's down button is the one on the right.)

Head back to the Oracle and click on the Control Center option. A new exit from the Oracle's chambers appears. Click on it to teleport to the Control Center.



CONTROL CENTER QUEST

The Control Center is *not* a nice place. It's full of flying robots with energy attacks that can kill you in one shot. This is considered an essential quest, but there's no objective that will reward you with experience points, gold, and the like. You'll learn some of the history of Enroth and the spacefaring civilization that created it, and you'll get the game's most powerful weapons—Blasters and Blaster Rifles—with which you can complete the final quest—Destroy the Hive. Simply follow the maps for the Control Center to find all the weapons and histories. Don't forget to learn the Blaster skill. Take the first left from the entrance and click on the panel in the first room to learn this skill.

After you have all the weapons, exit the Control Center. Talk to the Oracle again. It tells you about the Ancients and their enemy, the Kreegan, who threaten now to destroy the world. You know the Kreegan as the “Demons” who've entered this world and become the force behind the Temple of Baa. In the course of these explanations, the Oracle tells you how to defeat the Kreegan on Enroth. It also tells you that Archibald, King Roland's evil brother, is the only person in Enroth who might know of a spell powerful enough to contain the energies of the explosion you must create to destroy the gate linking their world to Enroth's.

RELEASE ARCHIBALD QUEST

The Oracle has told you that the only person who may know a spell powerful enough to contain the energies of the Kreegan's Reactor Core in an explosion is Archibald, King Roland's evil brother. Go to Castle Ironfist and talk to Nicolai about his Uncle Archibald. He tells you that to retrieve the bell that turned Archibald to stone, he needs a gem called the Third Eye. If you paid attention to the letters Roland wrote to his wife, you know that “the Third Eye is in the well.”



Figure 9-15 Releasing Archibald is risky, but worth it.

Ah, but which well?

Exit the castle and go to the well to its northwest. Click on it to retrieve the Third Eye. Reenter the castle and talk to Nicolai about his uncle again. He takes the Third Eye from you and gives you Tanir's Bell in exchange. Exit the castle again and walk around it to the north. Go up the ramp there and open the door facing north into the castle. Archibald immediately turns to flesh. Click on the Release Archibald menu item and he talks to you for a moment before he disappears. Before he leaves, he gives you the Ritual of the Void Scroll—the only other thing you need to win the game. Time to complete the game's final quest.

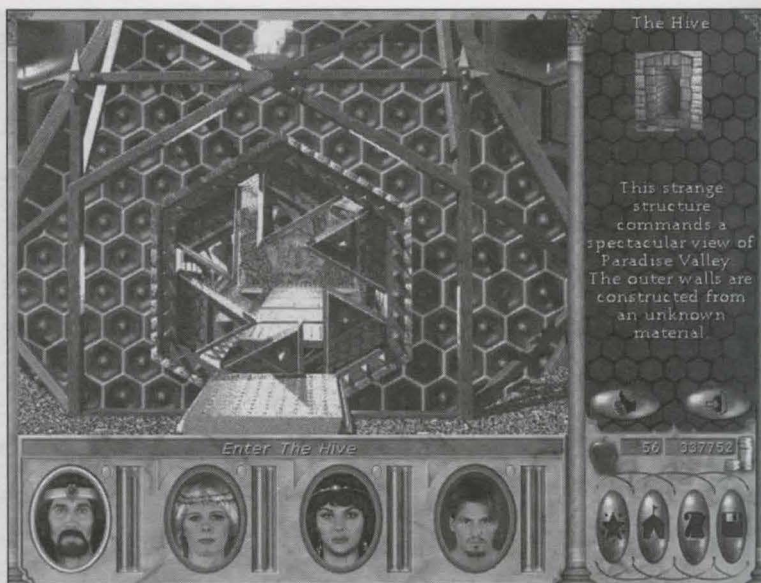

Figure 9-16 *The Beginning of the End*

THE HIVE QUEST

Equip your Blasters and/or Blaster Rifles! From where you enter the Hive, go straight forward to a ledge overlooking a large, somewhat circular room. Cast Feather Fall and step off the ledge. In the northeast part of the room, drop through the hole in the floor. Follow the tunnel as it winds around until you come to the second intersection. Turn right, open the chest you find there, and retrieve the Hive Sanctum Key. Continue along your original path down the tunnel until you come to a door. Click on the door to open it, and then turn right. Follow this new tunnel down to a larger room, and then angle right toward the door in the room's far-right corner. Open the door with the Hive Sanctum Key and follow the tunnel down to the Hive Sanctum proper.



Dominating the room in front of you is the Reactor Core. As soon as you enter the Hive Sanctum, the Reactor Core will begin defending itself against you. Fire your weapons directly at the core until you destroy it. After you reduce the core to tiny little pieces, the room's walls descend, followed immediately by a swarm attack of Kreegan minions. Across the room from where you entered lies a short passage where the Hive Queen blocks your only escape route. Kill her as quickly as possible and step through the gate she blocked.

If you have the Ritual of the Void Scroll from Archibald, you win the game and wind up back in New Sorpigal to terrorize the local population as you see fit.

If you're *not* carrying the scroll, the world is destroyed and you lose the game.

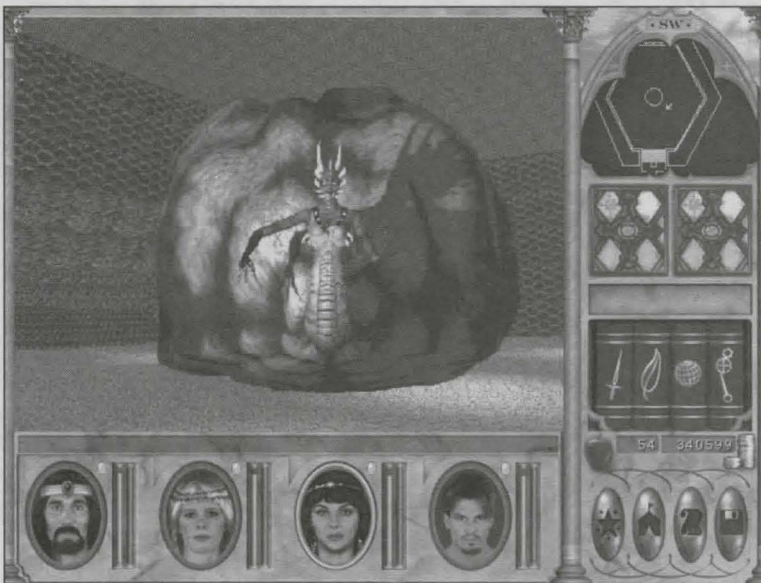
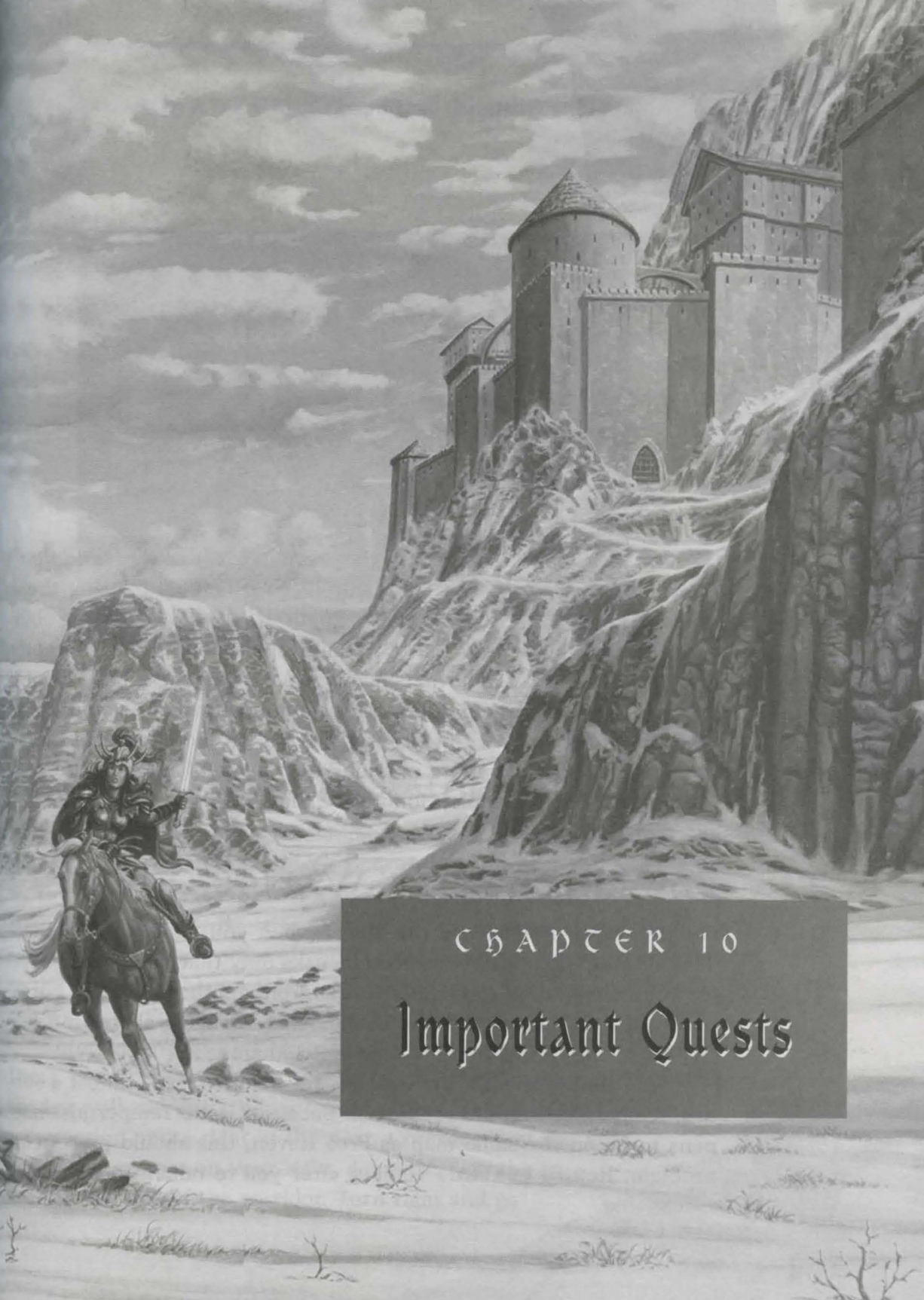

Figure 9-17 *The Hive Queen in all her glory*





CHAPTER 10

Important Quests



Although they're not part of *The Mandate of Heaven's* main story line, you should consider completing these quests. Doing so allows your party to advance in their fighting abilities and can make your party virtually invincible. Each character class has two potential advancements; we explore these first. Even if you don't have a particular character class in your party, you can still perform all the quests. But instead of being promoted to that class's new rank, party members outside the class will receive the title "Honorary"—for example, Honorary Champion.

THE KNIGHT-TO-CAVALIER QUEST

Osric Temper assigns you this quest when you visit him at Castle Temper (Map C2). It's very short; he asks only that you get approval for your nomination to Cavalier status from another Cavalier. Fortunately, the Cavalier Chadwick Blackpoole is hanging about in a tavern Rockham's Pride, in the village of Rockham.

"Where's Rockham?" you ask. It's the small village (almost a suburb, really) just west of Free Haven. Because Castle Temper just happens to be on the same map as Free Haven, this should present no problem. Return to Castle Temper after you've talked to Chadwick Blackpoole.



Figure 10-1 *Osric Temper, Lord of the West and Foremost Knight of the Realm*

THE CAVALIER-TO-CHAMPION QUEST

Again, you must talk to Osric Temper to obtain this quest. The task he sets before you is to defeat a powerful enemy, a man known only as the Warlord. Lord Temper allows that the Warlord is holed up somewhere just northeast of Icewind Pass; you must defeat the Warlord and bring back proof of your accomplishment. Icewind Pass lies in the Frozen Highlands (Map C1), just north of Free Haven; however, the Warlord's Fortress is in Silver Cove (Map D1).

Enter the Warlord's Fortress and proceed to the end of the hall. Don't bother messing with the door; it's false. Instead, turn toward the left wall and open the secret door there. Take a left at the first intersection and a right at the next. Continue past the false door that appears on your right, going through the true door at the end of the corridor. Turn right and go

up the steps; keep following this hallway until you get to a large, square room. Cross the room to the door on the other side. Go through it and turn left to enter the antechamber there. In the left-hand cabinet you'll find the Warlord's Key, which opens this room's only other door. The small closet beyond that door holds a chest that, in turn, holds the Warlord's Discharge Papers. Take them back to Osric Temper to ascend to the rank of Champion.

THE PALADIN-TO-CRUSADER QUEST

Good old Regent Wilbur Humphrey, Foremost Paladin of Enroth, is in charge of the Paladin-promotion quests. Visit him in Castle Ironfist (Map D3). The task you must carry out is a classic: You must rescue a damsel in distress. Ruffians hold Melody Silver captive on the Island



Figure 10-2 *The Knife Shoppe in New Sorspigel*

CHAPTER 10 Important Quests



I M P O R T A N T Q U E S T S

of Mist (Map E2). Head there and ask around. You'll eventually learn something about her father, John Silver, and the band of vigilantes he helped organize, the Silver Helms. It seems the Silver Helms turned bad and kidnapped Melody Silver. You must raid the Silver Helm Outpost, just outside the town of Mist, to free her.

Enter the outpost and descend the ramp ahead. As you enter the mess hall, turn and go through the first doorway on your right. Follow the hall back as far as it goes; then press on the wall at the end to open a secret door there. Keep going until you reach another ramp. Go up the ramp and enter the room on the right. At the back of the room is a switch button; pressing it opens a set of retractable ramps in the large room just outside this room.

Walk back to the top of the ramp and turn right; you should be able to see the first two ramp sections ahead. The trick is that the ramp sections extend from the wall as you walk up them, but retract into the wall again as you continue up the ramp. You're in constant danger of sliding backward, so you need a light touch to make it through this area. Cast Feather Fall if you fall off; it's the only spell that can save you from certain injury and possible death.

When you reach the last platform at the top of the ramp, it rises to a ledge. Step onto the ledge and go through the only open doorway you can see. Go straight toward the mural ahead and turn left at the intersection. Touch the wall in front of you to open yet another secret door; just inside waits Melody Silver, who joins your party until she's safely back at Castle Ironfist. To exit the Silver Helm Outpost, return to the mural you just passed and touch it to teleport to the room with the switch button. Exit that room and jump off the low platform at its entrance; then turn left and touch the mural there to teleport to the bottom of the ramp just below the outpost entrance. Return to Castle Ironfist with Melody Silver and talk to Wilbur Humphrey, who promotes you to the rank of Crusader.

THE CRUSADER-TO-HERO QUEST

For this quest to succeed, Wilbur Humphrey says you must *slay a dragon!* Specifically, you must slay Longfang Witherhide, whose lair is near Castle Darkmoor (Map C3). Get thee to the Mire of the Damned, anon!

If you have any experience slaying dragons, Longfang isn't much of a thrill. If he's your first dragon, though, you'll appreciate the danger you're putting your party in when you're about to set off for Dragonsand. Anyway, Longfang's lair lies directly north of Castle Darkmoor. It consists of one room, so don't bother checking the appendix for a map; there isn't one. Kill the dragon, take his claw, and return to Castle Ironfist with it.

THE ARCHER-TO-BATTLE MAGE QUEST

Lord Von Stromgard, keeper of the Frozen Highlands (Map C1), gives you this quest. If you've spent any time using the Fly spell around the more heavily populated areas, you may have noticed that some seriously strong fireballs keep pelting you. It seems that each major city has what's called a Dragon Tower, and it's programmed to shoot down anything flying through the area. Lord Von Stromgard believes these towers can be programmed to shoot only at flying *monsters* (which they should have been doing all along).

Unfortunately, Lord Von Stromgard left his Dragon Tower Keys behind when ogres overran his former castle, Icewind Keep. Your task, therefore, is simple: Retrieve the keys from Icewind Keep and return with them to Castle Stromgard.

Icewind Keep lies south of Castle Stromgard, along the road to Free Haven. Enter the keep and turn left at the end of the main hallway. Follow this eastern corridor all the way to the door at its end. Open the door and enter the small chamber. From here, open the



Figure 10-3 *Erik Von Stromgard, Marquis of the Northern Marches*

right-hand door in the north wall and flip the switch you'll find inside. Exit this area and return to the first intersection off the entry hall. Continue around the western hallway and proceed through the door at its end. This room is a mirror image of the room you were just in on the eastern side of the keep, so this time open the left door. Flip the switch inside and return to the intersection off the main entryway.

A large door has opened in the wall here. Go through it and proceed north. Both side passages lead to the same place, so choose either one. Continue north to the throne room. On the arm of the right-hand throne is a small lever. Pull it to open a secret door in the eastern wall. Enter this new area and follow the sloping passage to its end, where you'll find four chests. The northeastern chest holds the Dragon Tower Keys. Take them and exit the keep. Return to Castle Stromgard to receive your promotion.

THE BATTLE MAGE-TO-WARRIOR MAGE QUEST

Now you must go to each of Enroth's six Dragon Towers. You'll find one each in Blackshire (Map B2), Frozen Highlands (Map C1), Free Haven (Map C2), Silver Cove (Map D1), Mist (Map E2), and New Sorpigal (Map E3). Walk to the base of each tower and search for the keyhole. (The character who holds the Dragon Tower Keys should be the one to click on each keyhole.) After you've reprogrammed all six towers, return to Lord Von Stromgard for your promotion.

THE CLERIC-TO-PRIEST QUEST

In addition to monitoring "unlicensed" business, Lord Stone is also Enroth's High Priest. Thus, it's his duty to promote Clerics to Priests, and even to High Priests, when it's called for. Unfortunately, there are no openings for new Priests. However, Lord Stone tells you that, if you were to rebuild a temple that burned recently near Free Haven, he could promote you to the new rank: Then there would be some vacancies within the Church.

Setting up this quest is a challenge. First, go to Castle Stone (Map C1) and talk to Lord Stone about Temple Stone. He provides the temple's approximate location (near Free Haven, Map C2) and the quest's particulars: You must seek a stonemason NPC and a carpenter NPC, convince them to join your party, and take them to the ruined temple. Finding these NPCs is the hardest part of the quest, but there are at least two of each type either living in the houses of Free Haven or wandering that city's streets. Just keep talking to people and eventually you'll encounter them. Then it's simply a matter of taking them to the Free Haven Temple, Free Haven's northwesternmost building. The NPCs will leave your party automatically when you enter the temple; simply return to Castle Stone to receive your promotion.



Figure 10-4 Anthony Stone, High Priest of Free Haven

THE PRIEST-TO-HIGH PRIEST QUEST

Again, you pick up this quest at Castle Stone (Map C1). Click on the Sacred Chalice conversation topic and you'll be on your way to the rank of High Priest. Lord Stone tells you that a group of heretical monks has stolen the Church's Sacred Chalice and hidden it in their temple, which lies somewhere in the islands east of Free Haven (Bootleg Bay, Map B2). But there are three temples on those islands, and Lord Stone doesn't say which group of heretical monks is responsible. After you have the Sacred Chalice, though, you're to return it to the temple you so recently rebuilt (Free Haven Temple, Map C2), and then return to Lord Stone for your promotion.

Fortunately, although Lord Stone doesn't know which temple holds the Sacred Chalice, I do. Proceed directly to the Temple of the Sun, located on the L-shaped island in the center of Bootleg Bay. The Water Walk spell comes in quite handy in this quest; if you attempt this quest with four Knights, you'll need two scrolls of Water Walk (one in, one out). As

you enter the temple's narthex, proceed directly across the nave to the chancel, toward the obvious door in the room's far-left corner. Open the door and walk around the corner ahead. As you enter the small room at the end of this short corridor, you'll find the Sacred Chalice in the cabinet to your immediate right. Retrieve it, exit the Temple of the Sun, return the Sacred Chalice to Free Haven Temple, and then go see Lord Stone about your promotion to High Priest.

THE SORCERER-TO-WIZARD QUEST

Go to Castle Newton (Map E2) and speak to Lord Newton about your promotion to the rank of Wizard. The task he demands of you to test your mettle seems easy enough: Find the Fountain of Magic, drink from it, and return to him once you've done so.

Fortune smiles on you for purchasing this guide, however. I know exactly where to find the Fountain of Magic—Bootleg Bay (Map D2). Go to the fountain just northeast of the small southern village of



Figure 10-5 *Albert Newton, Marquis of Mist and High Sorcerer of Enroth*



Harecksburg on the mainland, have *all* party members drink from it, and then return to Castle Newton.

THE WIZARD-TO-ARCH MAGE QUEST

Funny thing. Lord Newton gives you this quest, too. Are you beginning to see a pattern to the class-promotion quests? This quest, though, is truly bizarre. Lord Newton wants you to retrieve an artifact, but he can't seem to remember what the artifact is.

"I know it can be found in Corlagon's Estate in the Mire of the Damned," he tells you (Map C3). But, because Lord Newton's memory is less than completely reliable, can you really trust this information? Hmmm. This could be a lengthy search. . . .

Corlagon's Estate actually lies northeast of the Mire of the Damned, in the far southwest corner of the lands around Castle Ironfist (Map D3). The artifact you seek is the Crystal of Terrax. Forewarned is forearmed: Corlagon's Estate is full of the undead and has many twisting passageways and barred doors with remote switches. In other words, you'll spend a lot of time running around in there.

From where you enter, go straight through to a T intersection. Turn right and enter the room ahead. Open the door on its north wall and go to the next room. Open the door on its east wall and follow the corridor to its first intersection, where a hallway leads to the right. Head down this passage, across a room full of trash heaps until you emerge on a raised platform above a very deep, largish room. Walk carefully along the platform and out of the room. You'll hit a teleporter as you round the next corner, but it just sends you to the far end of this hallway. Keep following this corridor, ignoring all branching passages until you come to the door at its end. Open it and turn left as you pass through. The small room in this direction has a button on the back wall. Press it and retrace your steps to the intersection just north of the entrance.

Head west into a small room, turn right, and

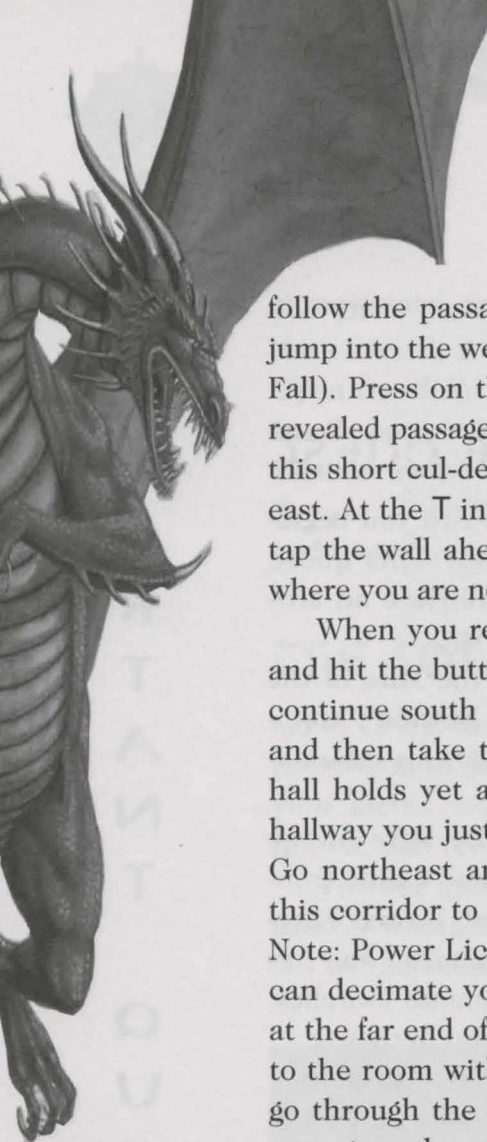

follow the passage all the way to its end. Open the door there and jump into the well ahead (it's not very deep, so you won't need Feather Fall). Press on the west wall to open a secret door. Follow this newly revealed passageway to the first intersection leading left. At the end of this short cul-de-sac is another button. Push it, turn around, and head east. At the T intersection, go left; when you reach the end of the hall, tap the wall ahead to open another secret door. It should be obvious where you are now, so retrace your steps to the room with the well.

When you reach it, turn left. Turn right at your first opportunity and hit the button at the end of the corridor there. Turn around and continue south to a small oval room. Turn left, go through the door, and then take the first available right. The room at the end of this hall holds yet another button; press it and return to the east-west hallway you just left. Head east to a room with an overhead platform. Go northeast and pass through the doorway you find there. Follow this corridor to its end, where you'll enter a room with a Power Lich. Note: Power Liches are extremely tough. Don't toy with it, because it can decimate your party very quickly. Once it's dead, open the chest at the far end of the room. Retrieve the Crystal of Terrax; then return to the room with the overhead platform. Turn right as you enter and go through the door on the other side of the room. Proceed up this passage and you'll soon be back at the entrance to Corlagon's Estate.

Return the Crystal of Terrax to Lord Newton to receive your promotion.

THE DRUID-TO-GREAT DRUID QUEST

This is a nifty, if time-consuming, quest. Go see Loretta Fleise in her castle in Silver Cove (Map D1) and she'll give you the quest. To ascend to Great Druid status, you must stand in the Circle of Stones at noon during an equinox or a solstice—March 20 (vernal equinox); June 21 (summer solstice); September 23 (autumnal equinox), or December 21 (winter solstice).

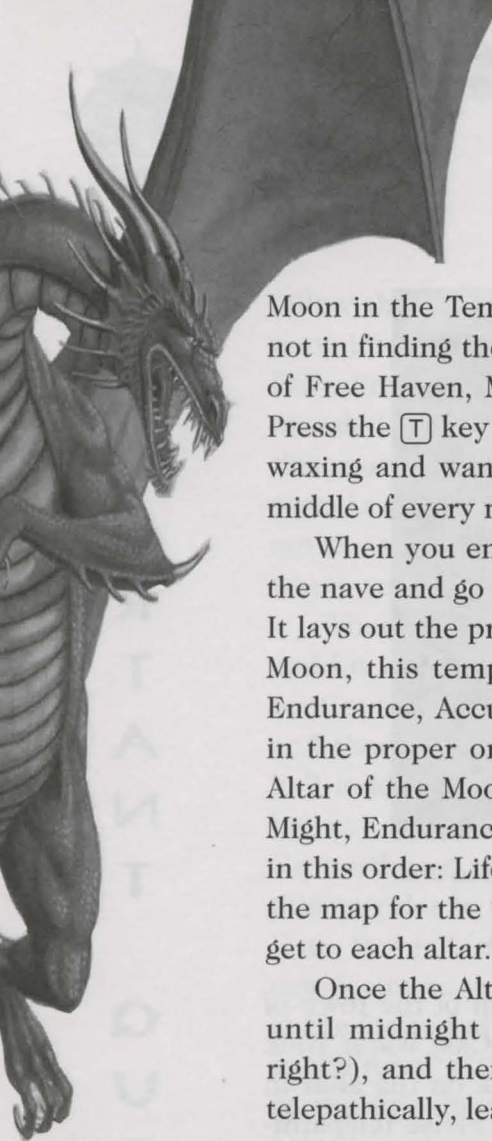

Figure 10-6 *Loretta Fleise, Baroness of the Eastern Sea and Chancellor of the Treasury*

You'll find the Circle of Stones on an island north of the town of Silver Cove (Map D1, the map you're currently on). Cast Water Walk to get out to it. At the appointed date and time, click on the altar in the center of the Circle of Stones to talk to Loretta Fleise telepathically. She'll run you through the ceremony and promote your party to the rank of Great Druid (or Honorary Great Druid, if you have no Druids in your party). The problem with this quest is that it's so time-specific: There are only four days each year during which you can complete it.

THE GREAT DRUID-TO-ARCH DRUID QUEST

Loretta Fleise tells you that, to achieve the rank of Arch Druid, you must pray at midnight at the Altar of the



Moon in the Temple of the Moon during a full moon. The trouble lies not in finding the Temple of the Moon (it's in the northwestern region of Free Haven, Map C2), but in determining when the moon is full. Press the **T** key to view a screen that shows, among other things, the waxing and waning of the moon. Generally, the moon is full at the middle of every month, around the 15th, so plan accordingly.

When you enter the Temple of the Moon, proceed directly across the nave and go up the steps. Examine the sign above the door there: It lays out the proper order of prayer for you. Besides the Altar of the Moon, this temple has six other altars—one each for Life, Might, Endurance, Accuracy, Speed, and Luck. You must pray at each (and in the proper order to get the stat bonus) to open the door to the Altar of the Moon. The sign reads, “Life above all, Accuracy before Might, Endurance before Speed, and finally, Luck.” So visit the altars in this order: Life, Accuracy, Might, Endurance, Speed, Luck. Refer to the map for the Temple of the Moon for explicit directions on how to get to each altar.

Once the Altar of the Moon door opens, go to the altar and wait until midnight (you've timed this to coincide with a full moon, right?), and then click on the altar. Loretta Fleise will contact you telepathically, lead you through the ceremony, and promote you.

THE SEER QUEST

The Seer lives in a small temple atop the mountain opposite Castle Ironfist. Every month, he'll give you a new quest. It's in your best interests to complete each of them.

Basically, the Seer will tell you to go pray at a shrine. If you make it to the shrine before the month is out, you'll receive a +10 bonus to the statistic or resistance that he names. Each month activates a different shrine, but only after you talk to the Seer. (In other words, you can't simply travel to a shrine if you know what month it's active.)



Figure 10-7 *The Seer*

You can repeat these quests year after year, but the increase drops to +3 once you've completed a particular statistic's quest.

MONTH	ACTIVE SHRINE
January	Shrine of Might
February	Shrine of Intellect
March	Shrine of Personality
April	Shrine of Endurance
May	Shrine of Accuracy
June	Shrine of Speed
July	Shrine of Luck
August	Shrine of Fire Resistance
September	Shrine of Electricity
October	Shrine of Cold
November	Shrine of Poison
December	Shrine of Magic





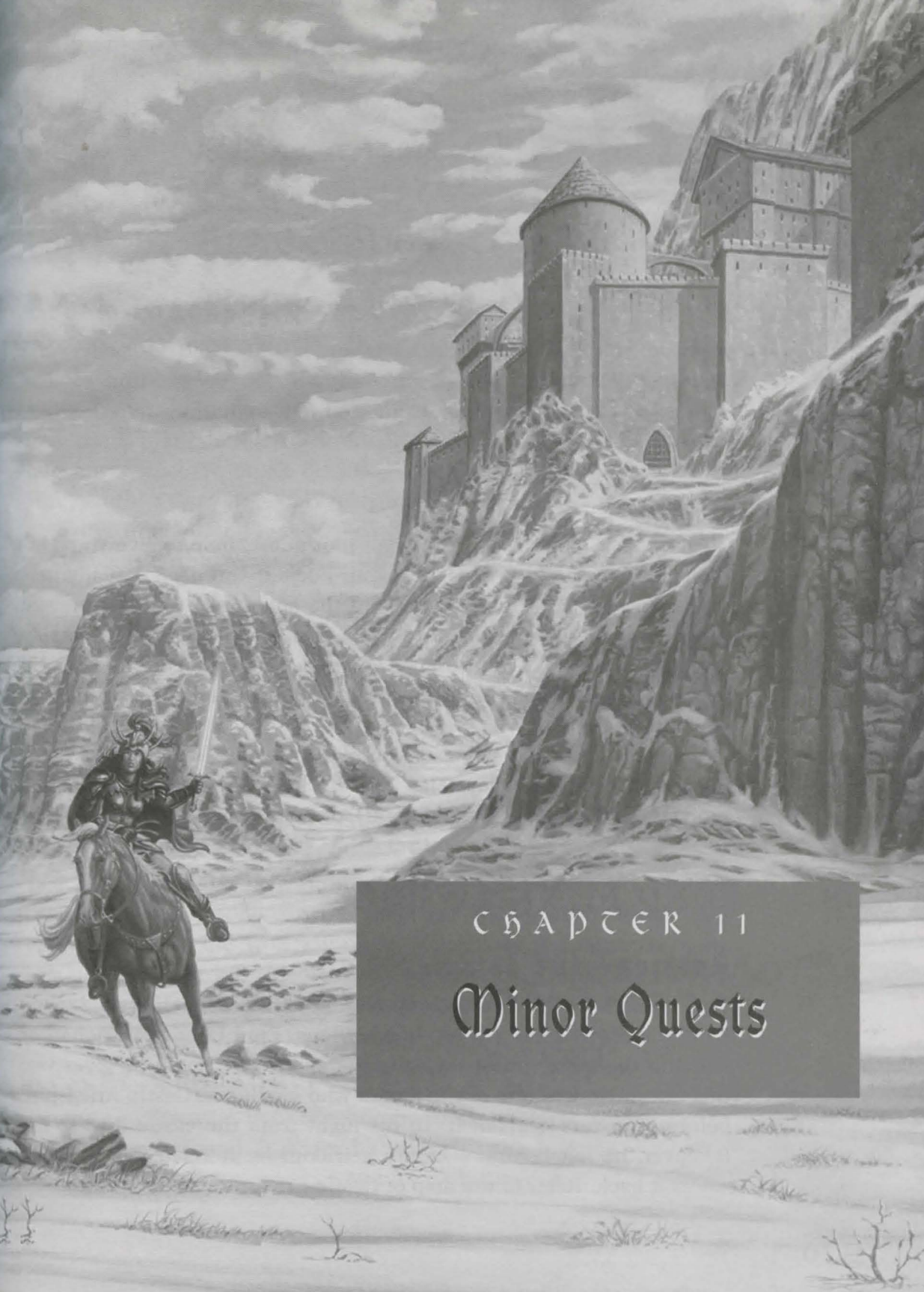

CHAPTER 11

Minor Quests



Minor quests help to give you a little experience and some cash in your pocket. You need actually perform none of these quests, ever, and the amount of time you devote to each—if any—is entirely up to you. Most players will want to experience as much of *The Mandate of Heaven* as they can, and so will perform these tasks. The quests are grouped by the outdoor map on which they begin.

There are no minor quests you can undertake from Sweet Water (Map A1), Paradise Valley (Map A2), Hermit's Isle (Map A3), Dragon-sand (Map B3), Bootleg Bay (Map D2), or Eel-Infested Waters (Map E1).

MAP B1: KRIEGSPIRE

Retrieve the Jeweled Egg

This quest is best taken in conjunction with Oracle Quest Subquest D. The reasons soon will become obvious. Emil Lime, an Enchanter living in the easternmost house in the village of Kriegspire, gives you this quest. He was one of the mages who studied at Castle Kriegspire before monsters overran it. In his flight from the castle during the takeover, he left behind a family heirloom—a Jeweled Egg. Now he wants it back. Refer to the map of Castle Kriegspire for its location.



MAP B2: BLACKSHIRE

Break Blackshire's Curse

The village of Blackshire is under a curse, if the number of Werewolves running loose about the countryside weren't clue enough. Maria Trepan, who lives in a house just southeast of the village fountain, though, knows the truth. Under a full moon, every villager turns into a werewolf. To break the curse, you must enter the Lair of the Wolf, south of the village of Blackshire.

Enter the Lair and make for the Ghost of Balthasar. He was a Paladin killed by the Werewolves roaming this lair. He tells of an item called the Pearl of Purity that has the power to remove the Blackshire Curse. You can also run the next quest ("Kill the Werewolf Leader") by clicking on Balthasar's Quest conversation topic. The Pearl of Purity lies at the extreme northeastern tip of the Lair of the Wolf; simply retrieve it and click on the Wolf Altar to remove the Blackshire Curse. After you destroy the Wolf Altar, take the Pearl of Purity to Wilbur Humphrey, who rewards you.

Kill the Werewolf Leader

The Ghost of Balthasar can't rest until the Werewolf Leader is destroyed. After you destroy the Wolf Altar, the magically locked door in the Mouth of the Wolf will open. Make your way upstairs to the second level and kill the Werewolf Leader; then take the Pearl of Putrescence back to the Ghost of Balthasar.

Rescue Emmanuel

Joanne Cravitz, who lives two houses south of Maria Trepan, has lost her husband. It seems he went treasure hunting on Star Island a few weeks ago and hasn't been seen

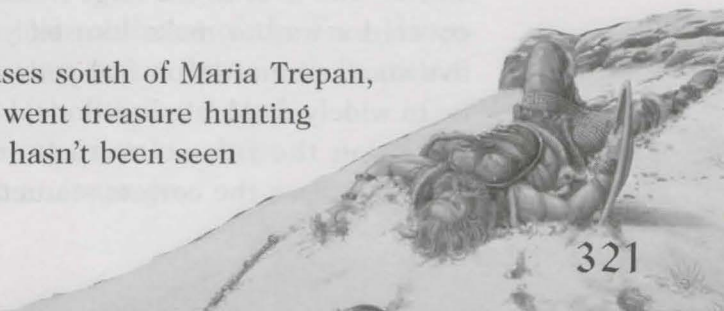

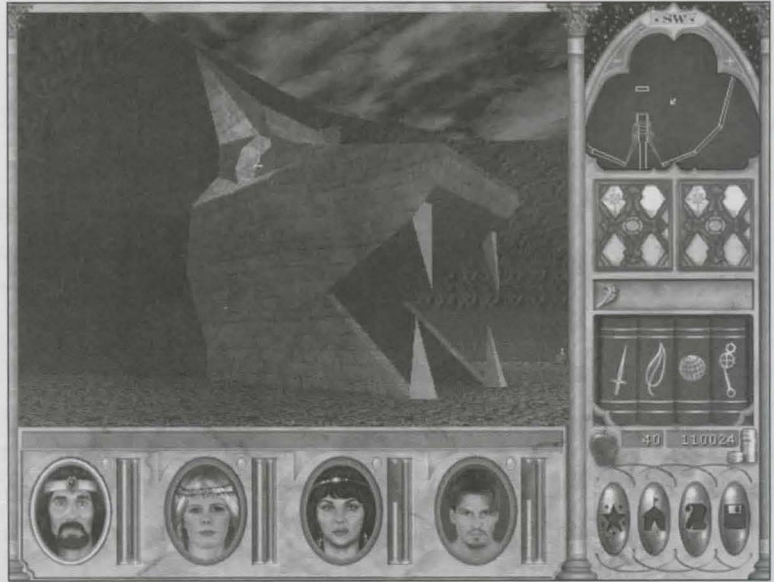

Figure 11-1 *The Mouth of the Wolf*

since. Star Island lies directly west of Joanne's house, and you'll need either a Water Walk spell or a Fly spell to get there.

On the island is the Temple of the Snake. That's where you'll find Emmanuel. A note of caution: The Temple of the Snake is full of Gorgons and Medusas, as well as nasty tricks and traps. Examine the map carefully before you enter.

Place the Statuettes

You receive this quest in Blackshire, from Twillen, an elderly Gate Master who lives in the large house on the east edge of town. He's discovered a way to make himself young again, but it involves placing five small statuettes on five pedestals. Unfortunately, these pedestals lie in widely disparate locations, all fairly dangerous to get to. Twillen gives you the five statuettes, and you must then travel to each pedestal, place the correct statuette upon it, and, after you've placed



all five, return to Twillen for your reward. The pedestals are located in Sweet Water, Kriegspire, Dragonsand, Mire of the Damned, and Bootleg Bay.

MAP C1: FROZEN HIGHLANDS

The Ankh Quest

Anthony Stone in Castle Stone gives you this quest. It seems the Silver Helms have begun to cut into Lord Stone's piece of the pie, and he wants you to talk to John Silver, their leader, about why this is so. Oddly, Loretta Fleise (Map D1) also believes the Silver Helms have been overstepping their bounds. That the Silver Helm Stronghold sits squarely between castles Stone and Fleise should come as no surprise.

This is one of the game's longer minor quests. You'll discover that John Silver has been murdered (you'll talk to his ghost) by his former second-in-command, Gerrard Blackames, and that Blackames and his Sorcerer brother, Marcus, have ties to the Temple of Baa. As a bonus, if you've successfully performed the Paladin-to-Crusader class-promotion quest, John Silver gives you access to his private stash of goodies. He also gives you the lowdown on what this Ankh business is all about. Once you've collected the Ankh, take it back to whoever *didn't* give you the quest for a little in-game humor.

MAP C2: FREE HAVEN

Retrieve Ethric's Skull

Gabriel Cartman, whose house lies just southeast of the Free Haven Temple, gives you this quest, and it's very direct: Retrieve the remains of the first (and thus most powerful) Lich, Ethric the Mad.

Well, seeing as how Ethric's Tomb is only a hop, skip, and a jump away, why not at least go

check it out? It lies on the western fringe of Free Haven. The Tomb of Ethric the Mad is self-explanatory from the map; Ethric's Skull is the only quest item in the dungeon.

Find the Lost Artifact

Due south of the Free Haven fountain is the home of Zoltan Phelps, a merchant. It seems an explorer friend of his had offered to sell a rare artifact, Mordred, to Mr. Phelps. But bandits attacked the caravan bringing the artifact to Free Haven. Needless to say, the artifact is now missing.

The bandits "were last seen heading to an area west of Castle Temper," according to the merchant, and he's certain that they have some sort of base of operations around there. As it turns out, the base of operations is the Dragoons' Keep, due south of Free Haven.

Rescue Sherell

Carlo Tormini has a problem: Headhunters in Bootleg Bay have taken his good friend Sherell captive!

The cannibals have taken poor Sherell to their temple, and it's up to you to save her. She waits in the Temple of Tsantsa, on the northernmost large isle in Bootleg Bay.

MAP C3: MIRE OF THE DAMNED

Kill Snergle

Avinril Smithers is the former Dwarven Weaponmaster. You'll find him at a tavern known as The Haunt, just outside and east of the village of Darkmoor, through Death Valley. He was removed from his position following the usurpation of the Dwarven throne from Rocklin



by the evil-minded Snergle. Snergle is bad for the Dwarven kingdom, and Avinril Smithers recognizes that if Snergle isn't removed from power, the Dwarves' downfall will be at hand. In exchange, Avinril says he will train you in Dwarven axe-fighting. Kill Snergle and take his Axe to Avinril Smithers.

This quest is the only minor quest that sends you to two dungeons. First, go to Snergle's Iron Mines, just east of The Haunt, and retrieve Snergle's Key. Once you have the key, go to Snergle's Caverns and kill Snergle. Return to Avinril Smithers with Snergle's Axe to receive your gold and experience. Avinril Smithers will then teach you Axe Mastery for free, provided you're an expert in this skill already.

MAP D1: SILVER COVE

Ankh Quest

See the quest notes for Map C1: Frozen Highlands for details on this quest.

Deface the Altar

You receive this quest from Eleanor Vanderbilt, whose house lies just southeast of the Town Hall and northwest of Castle Fleise. She, like Lady Fleise, is disturbed by the rise to power of Cedric Druthers and his Celestial Order (a Druidic faction). She wants you to invade the ancient Druid temple they've taken over—the Monolith—and deface the altar they use for their ceremonies. The Monolith lies in the far-southwestern area of the Silver Cove region. The switches for the doors within the Monolith aren't obvious, but—follow carefully here—the nature of the place is vaguely unnatural. Return to Eleanor Vanderbilt after you've defaced the altar to collect your reward.

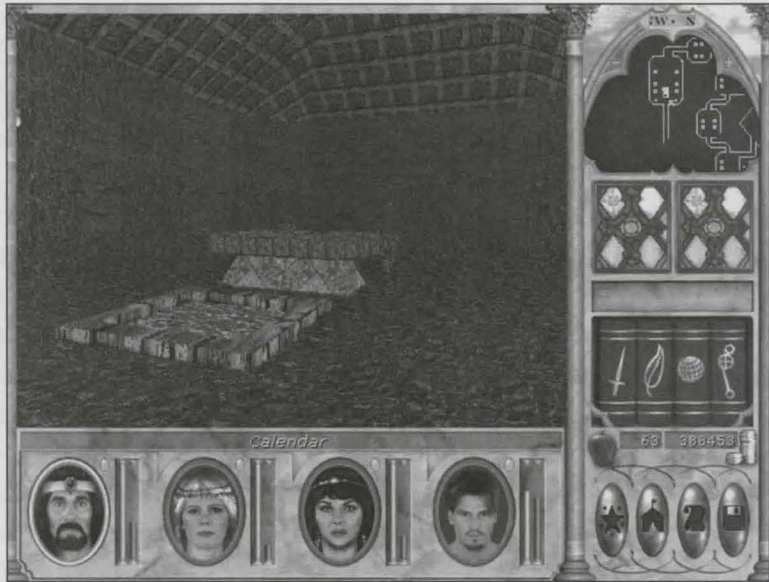

Figure 11-2 Altar and Main Temple of the Monolith

Silver Cove Bounty Quest

If you go to the Silver Cove Town Hall, you can pick up a quest to hunt down a specific type of monster. Because this quest varies from month to month, I can offer no help. Simply hunt down the monster they ask you to hunt and return within the month to collect your reward. (You probably should pick up this quest at the *beginning* of each month, rather than near the end.)

MAP D2: BOOTLEG BAY

Destroy the Crystal

Winston Schezar used to belong to the Temple of the Fist, but he resigned when the order discovered an evil, enchanted crystal and



began to explore its possibilities. After resigning, he moved into a wing of the Harecksburg Temple.

The Order of the Fist now seeks to use the crystal as a bargaining chip to gain entrance to, and acceptance within, the Temple of Baa. Winston Schezar wants to ensure that the Order of the Fist doesn't lose sight of the world, and he wants you to destroy the crystal. The Temple of the Fist lies just northwest of Harecksburg.

Unward the Doors

This is perhaps the game's only "secret" quest, as it requires you to talk to an inanimate wall. The quest begins when you enter the Hall of the Fire Lord and talk to the "face" near the entrance. This awakens the Lord of Fire, an elemental earth spirit, who tells you a story about how a creature unlike any the Lord of Fire has seen in Enroth

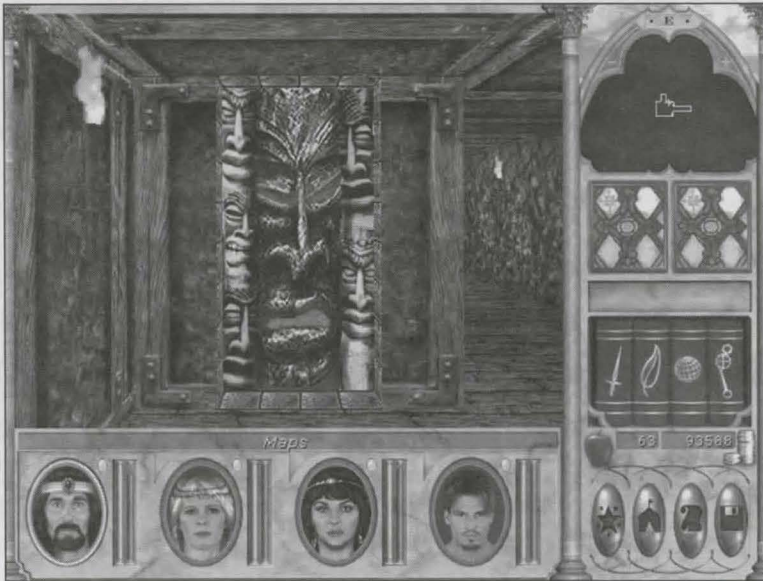

Figure 11-3 *The Knife Shoppe in New Sorpigal*

came to live in his hall. He describes how this creature sealed and warded its many doors, and how the Lord of Fire needs these doors opened so he may feed on the energies of the earth once again.

It's an interesting quest. It's also the most confusing of the minor quests. However, talk to the Lord of Fire about all the conversation topics you can; this helps immensely. Use a little caution: You must make numerous falls to complete this quest so keep a Feather Fall spell active at all times.

MAP D3: CASTLE IRONFIST

Retrieve the Harp

Andrew Besper, who lives in the shadow of Castle Ironfist's mountain, has had a caravan attacked by Dragoons. They've stolen a Harp of which Mr. Besper is extremely fond, and he'd like you to get it back. You'll find the Harp in the Dragoons' Caverns.

You probably should perform this quest in conjunction with the "Orders from the Shadow Guild" quest you can get from Frank Fairchild in New Sorpigal (the objects of both quests lie in the Dragoons' Caverns).

MAP E2: MISTY ISLANDS

Expose the Treachery of the Silver Helms

Mist's mayor, Bertrand Scrivner, is considering turning over the policing of the town to the Silver Helms. This concerns Charles D'Sorpigal. He's certain they've murdered innocent people in their misguided crusade against "evil" in the region, but there are no living witnesses



to possible atrocities. D'Sorpigal wants you to uncover proof of their misdeeds by storming their outpost in Mist. The map of the Silver Helms' Outpost provides clear directions to the Enemies List scroll. Return to D'Sorpigal with the scroll to collect your reward.

Mist Bounty Hunt

You receive this quest from Earnest, Mist's town clerk. It's similar to the aforementioned Silver Cove Bounty quest.

MAP E3: NEW SORPIGAL

Retrieve the Candelabra

Andover Potbello, who paid you for the Letter at the outset of the game, would like you to retrieve a special candelabra for him. When the followers of Baa abandoned the Temple of Baa to the northwest of town, they left behind this candelabra. Simply go to the Abandoned Temple of Baa, retrieve it, and return it to Andover Potbello for your reward.

Kill the Spider Queen

This is another quest involving the Abandoned Temple of Baa, but this time Buford T. Allman, who lives just northwest of Blades' End, would like you to kill the Spider Queen there. It seems giant spiders overrun New Sorpigal periodically, and, although none are around right now, Allman seems genuinely concerned about the situation. As proof of your deed, he asks that you return to him with the Spider Queen's heart.

Cobra Eggs

Hejaz Mawil, breeder of rare and exotic ophidians, lives behind the tavern. He's run out of breeding material, and wants you to retrieve some Cobra Eggs from the Abandoned Temple of Baa. They lie in a room just north of the Spider Queen's Lair. Incidentally, when you drop off the first batch of Cobra Eggs, Mawil mentions that he'll pay you for any more that you find. Keep this in mind; a few lie scattered around the land of Enroth.

Rescue Angela

Angela, Violet Dawson's daughter, seems to have gotten in a bit of trouble. If you go to her house just north of Blades' End, Violet Dawson explains how Angela ran off and is probably lost inside the Abandoned Temple of Baa. Find her and bring her back to collect your reward.

Goblinwatch Combination Quest

Janice, the clerk for the town of New Sorpigal, tells you of an embarrassing situation: An old keep, Goblinwatch, was built just southwest of town to keep out invading goblin hordes. But, King Roland's reign was so utterly peaceful that the town's vigilance waned, and right under their noses, a band of goblins moved into the keep. Worse, they've locked up a portion of the keep using a secret code, and the town must gain complete access. You needn't go in and slaughter everything in sight; just find the code and return it to Janice.



Figure 11-4 *Goblinwatch Keep's Code Keypad*

Retrieve the Chime of Harmony

You learn from Janice, the town clerk, that the community is concerned about caravan raiders on the trade route between New Sorpigo and Castle Ironfist. The culprits appear to be part of a new religious sect. They're holed up in a temple "a few days west" of New Sorpigo. Go to the Temple of Baa in the region of Castle Ironfist (Map D3). Find the Chime of Harmony and bring it back to Janice.

The Temple of Baa is a tough place, full of enemy traps that spring on you when you least expect them. To get to the key to the first door, you must hit the central temple doors in the following order: north, east, west, south. After that, the level is a cakewalk, provided you're well armed for magical attacks.

Rescue Sharry

Frank Fairchild, mayor of New Sorpigal, tells you an order of thugs called the Shadow Guild has moved into the area, and they've been extorting payments from New Sorpigal's merchants for "protection services." To ensure these payments, the Shadow Guild has kidnapped an old healer, Sharry Carnegie, much beloved by the townspeople. They hold her captive in their hideout in the northern area of the lands around Castle Ironfist (Map D3).

Orders from the Shadow Guild

Again, it's Frank Fairchild who offers you this quest and, again, it's the Shadow Guild he wants you to go after. This time, though, he wants you to retrieve proof of the Shadow Guild's illicit activities. With this proof, he could get Lord Stone to send troops to New Sorpigal to deal with the mess and end it once and for all.

But Frank is unclear about where and what this proof might be. Fortunately, you have this guide: Go to the Dragoons' Caverns in the southern region of the lands around Castle Ironfist.

New Sorpigal Bounty Quest

You receive this quest from Janice, New Sorpigal's town clerk. It's similar to the aforementioned Silver Cove Bounty quest.

ADDITIONAL PUZZLES

These puzzles are similar to quests, except that you gain only goodies, not experience. You may undertake them for the sake of completeness, or you can ignore them. They have no impact on your standing within the game.



Obelisk Puzzle

Go to each of the 15 Obelisks and click on its panel. You'll get a puzzle clue that, when organized properly, reveals the location of a treasure trove. In this trove are two Books of Learning, one for Divine Intervention and one for Dark Containment. This is the only place in the game where you can learn these spells. There are also a couple of very powerful artifacts in the treasure trove, as well as 250,000 gold pieces. You must trigger all the Obelisk events before the treasure trove is revealed and accessible.



Figure 11-5 One of the Game's 15 Obelisks

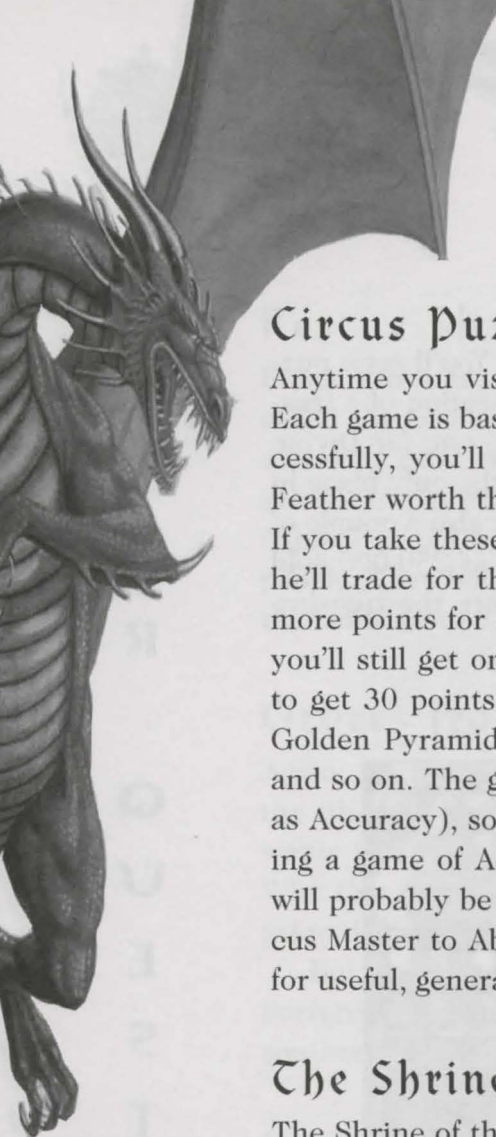

Circus Puzzle

Anytime you visit the Circus, there are some games you can play. Each game is based on a specific statistic, and, if you complete it successfully, you'll get a prize (a Lodestone worth one point, a Harpy Feather worth three points, or a Four Leaf Clover worth five points). If you take these prizes to the big top and talk to the Circus Master, he'll trade for them thus: 10 to 29 points for a Keg of Wine, 30 or more points for a Golden Pyramid. Note that if you have 500 points, you'll still get only *one* Golden Pyramid. Obviously, it behooves you to get 30 points, go talk to the Circus Master, exchange them for a Golden Pyramid, go back and play until you have 30 more points, and so on. The games are tied to the player's modified statistic (such as Accuracy), so if you cast Precision on a party member who's playing a game of Accuracy, the resulting score (and hence their prize) will probably be better. You can take the prizes you get from the Circus Master to Abdul's Desert Resort (in Dragonsand) and trade them for useful, generally high-level, items.

The Shrine of the Gods

The Shrine of the Gods is neither quest nor puzzle, but visit it whenever you can. It lies on a small island in northeast Dragonsand. Touching the small obelisk in the center of the shrine gives each party member +20 to all statistics.

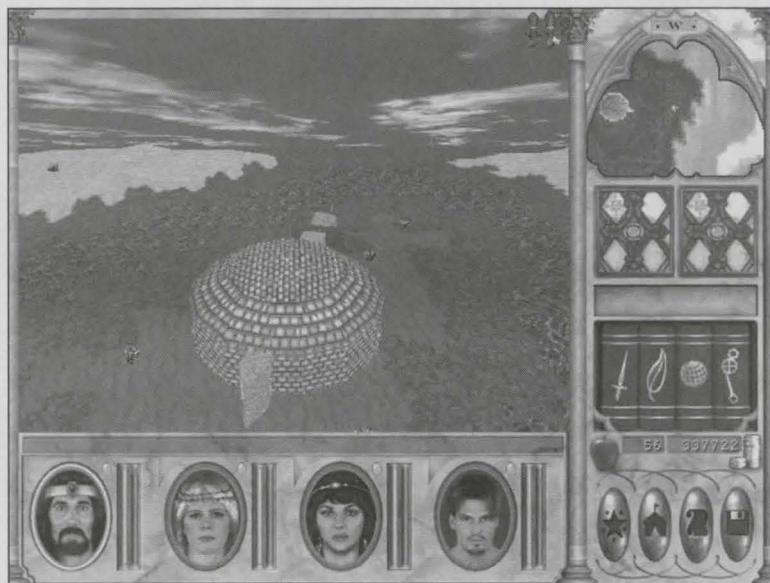
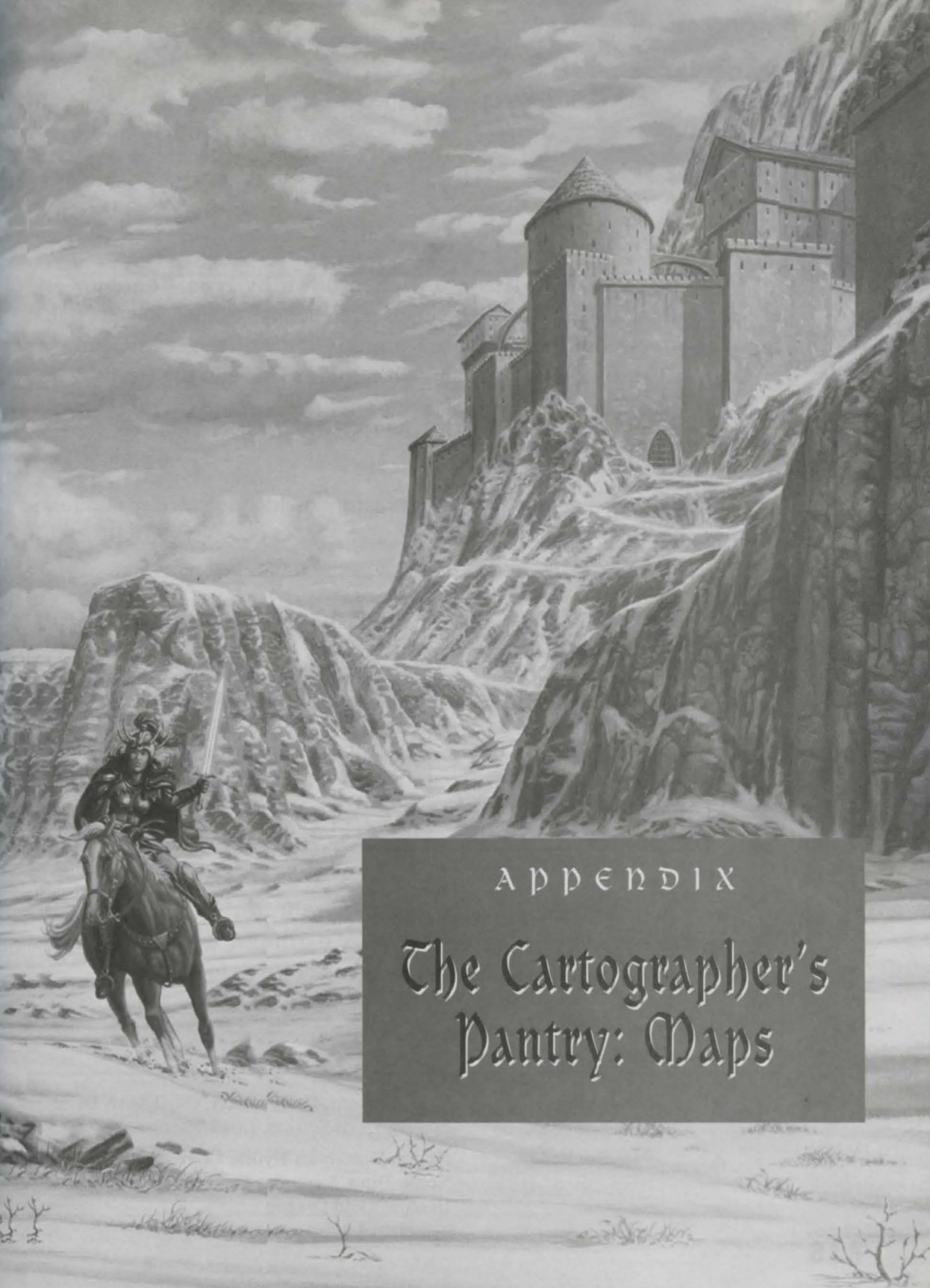

Figure 11-6 *The Shrine of the Gods (from Above)*







APPENDIX

The Cartographer's Pantry: Maps



The following maps are broken down by type—outdoor and indoor. Each section lists the maps alphabetically. Note, however, that single-room dungeons, where it's pretty difficult to get lost, have no maps. These include Longfang Witherhide's Lair and the Devils' Lair.

OUTDOOR MAPS

Outdoor maps comprise 15 map sectors divided into letter and number combinations:

A1	B1	C1	D1	E1
A2	B2	C2	D2	E2
A3	B3	C3	D3	E3

Each map contains monsters specific to it; for the most part, the monsters get tougher as you progress northwest from New Sorpigal (Map E3). The maps and monsters break down as follows.

MAP GRID	MAP NAME	MONSTER TYPES
A1	Sweet Water	Devil Captain, Devil Master, Devil King, Devil Spawn, Devil Worker, Devil Warrior
A2	Paradise Valley	Hydra, Venomous Hydra, Colossal Hydra, Titan, Noble Titan, Supreme Titan, Red Dragon, Blue Dragon, Gold Dragon

APPENDIX The Cartographer's Pantry: Maps



M A P S

MAP GRID	MAP NAME	MONSTER TYPES
A3	Hermit's Isle	Hydra, Venomous Hydra, Colossal Hydra, Sea Serpent, Sea Monster, Sea Terror, Titan, Noble Titan, Supreme Titan
B1	Kriegspire	Minotaur, Minotaur Mage, Minotaur King, Rock Beast, Earth Spirit, Earth Elemental, Flame Drake, Frost Drake, Energy Drake
B2	Blackshire	Wolfman, Werewolf, Greater Werewolf, Dust Devil, Twister, Air Elemental, Thunder Lizard, Lightning Lizard, Fire Lizard
B3	Dragonsand	Fire Lizard, Lightning Lizard, Thunder Lizard, Wyrms, Giant Wyrms, Great Wyrms, Red Dragons, Blue Dragons, Gold Dragons
C1	Frozen Highlands	Archer, Master Archer, Fire Archer, Magyar, Magyar Soldier, Magyar Matron, Harpy, Harpy Hag, Harpy Witch
C2	Free Haven	Apprentice Mage, Journeyman Mage, Mage, Archer, Master Archer, Fire Archer
C3	Mire of the Damned	Harpy, Harpy Hag, Harpy Witch, Skeleton, Skeleton Knight, Skeleton Lord, Ghost, Evil Spirit, Specter
D1	Silver Cove	Stone Gargoyle, Marble Gargoyle, Diamond Gargoyle, Druid, Great Druid, Grand Druid
D2	Bootleg Bay	Cannibal, Head Hunter, Witch Doctor, Lizard Man, Lizard Archer, Lizard Wizard
D3	Castle Ironfist	Lizard Man, Lizard Archer, Lizard Wizard, Follower of Baa, Mystic of Baa, Fanatic of Baa, Blood Sucker, Brain Sucker, Soul Sucker
E1	Eel-infested Waters	Agar's Pet, Agar's Monster, Agar's Abomination, Sea Serpent, Sea Monster, Sea Terror, Water Beast, Water Spirit, Water Elemental
E2	Misty Islands	Cutpurse, Bounty Hunter, Assassin, Follower of Baa, Fanatic of Baa, Mystic of Baa
E3	New Sorpigal	Goblin, Goblin Shaman, Goblin King, Apprentice Mage, Journeyman Mage, Mage

The Hive

Village of
Sweet Water

Tiger Pedestal



Map A1: Sweet Water

Obelisk

APPENDIX The Cartographer's Pantry:
Maps

Village of
Edenbrook

Obelisk

Temple of Baa

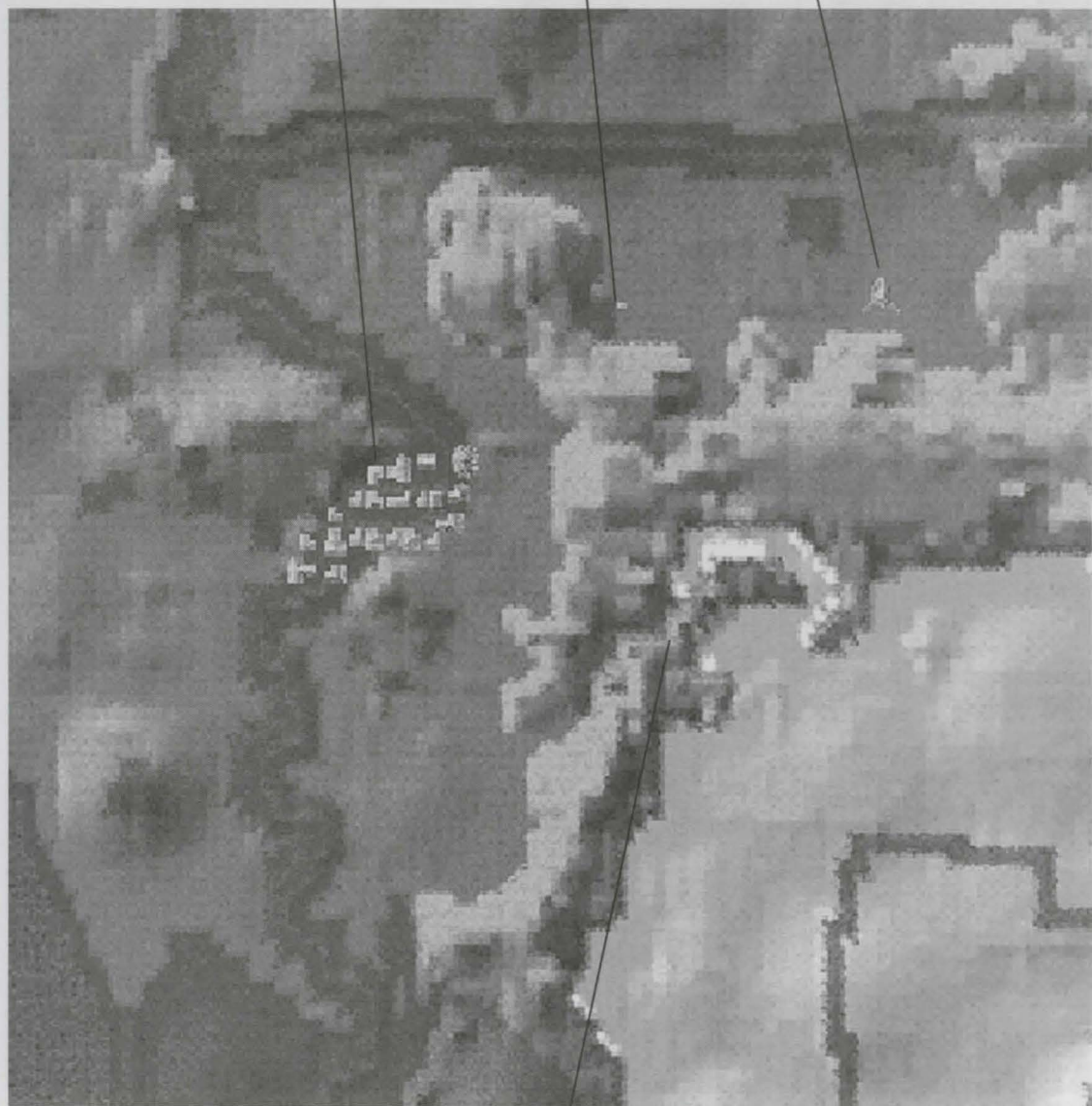

Map A2 Paradise Valley

Valley of the Titans

Obelisk

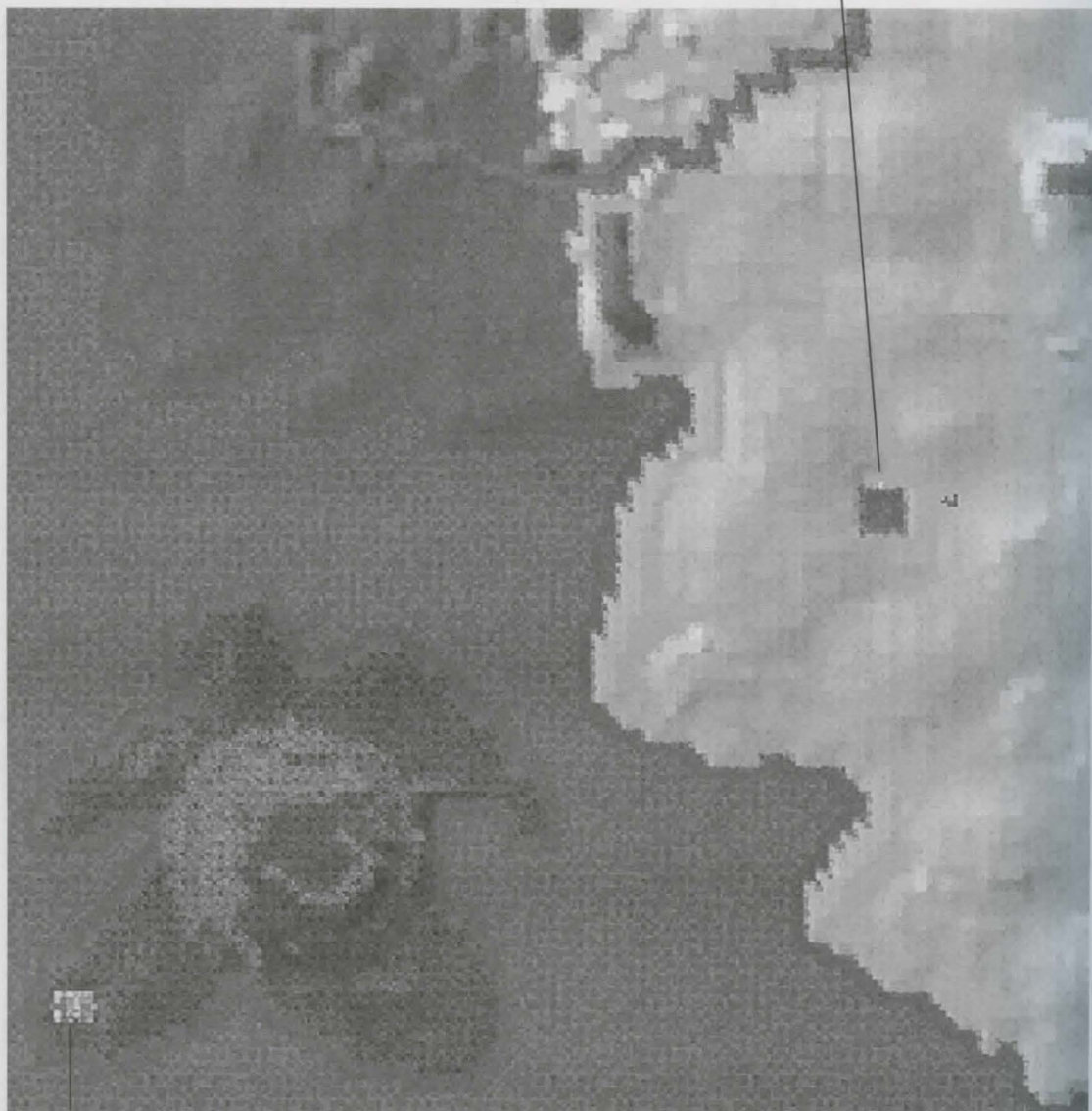

Supreme Temple of Baa

Map A3 Hermit's Isle

APPENDIX The Cartographer's Pantry:
Maps



MIȚT & MAGIC VI: The Mandate of Heaven

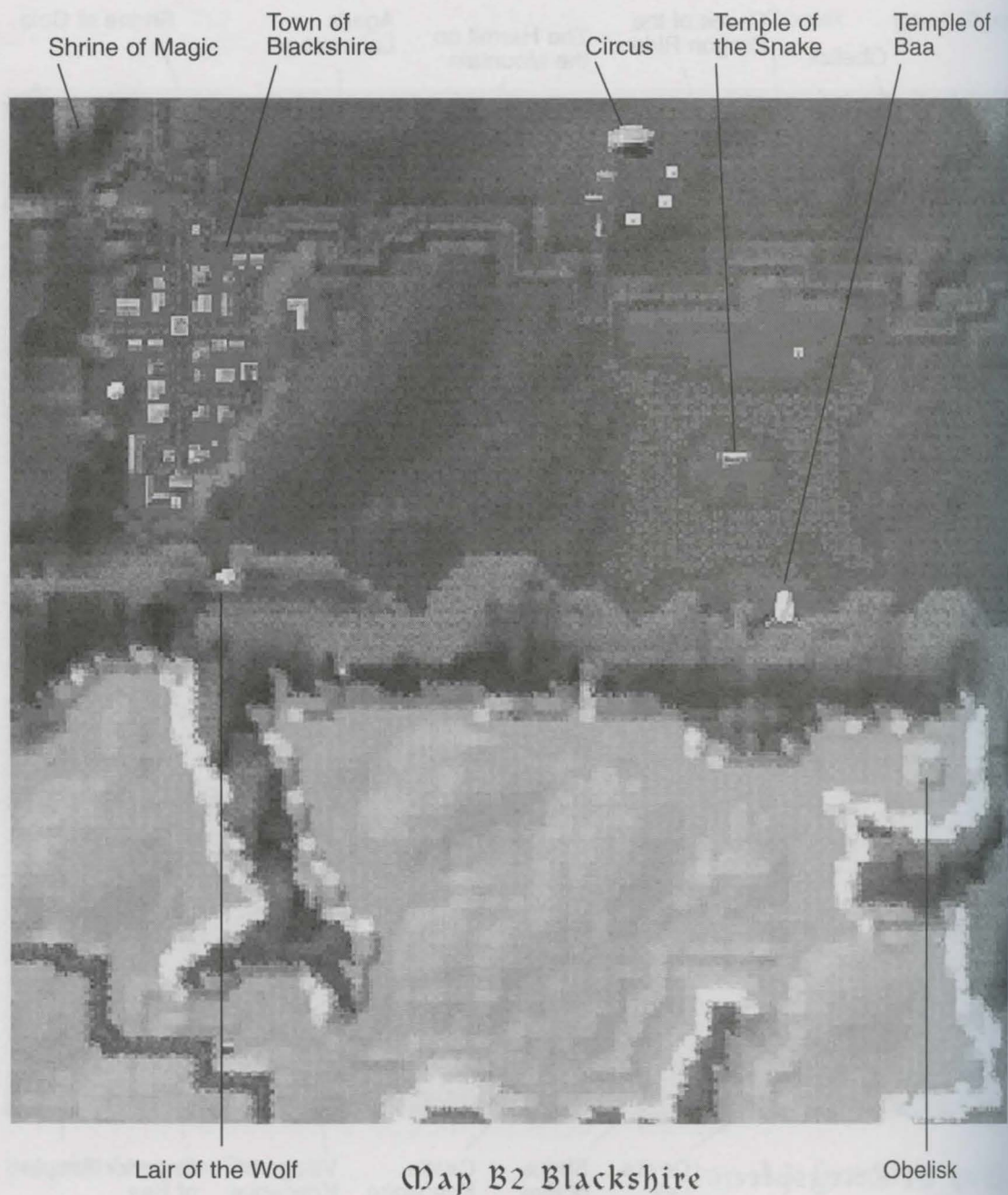

APPENDIX The Cartographer's Pantry:
Maps



Map B3 Dragonsand

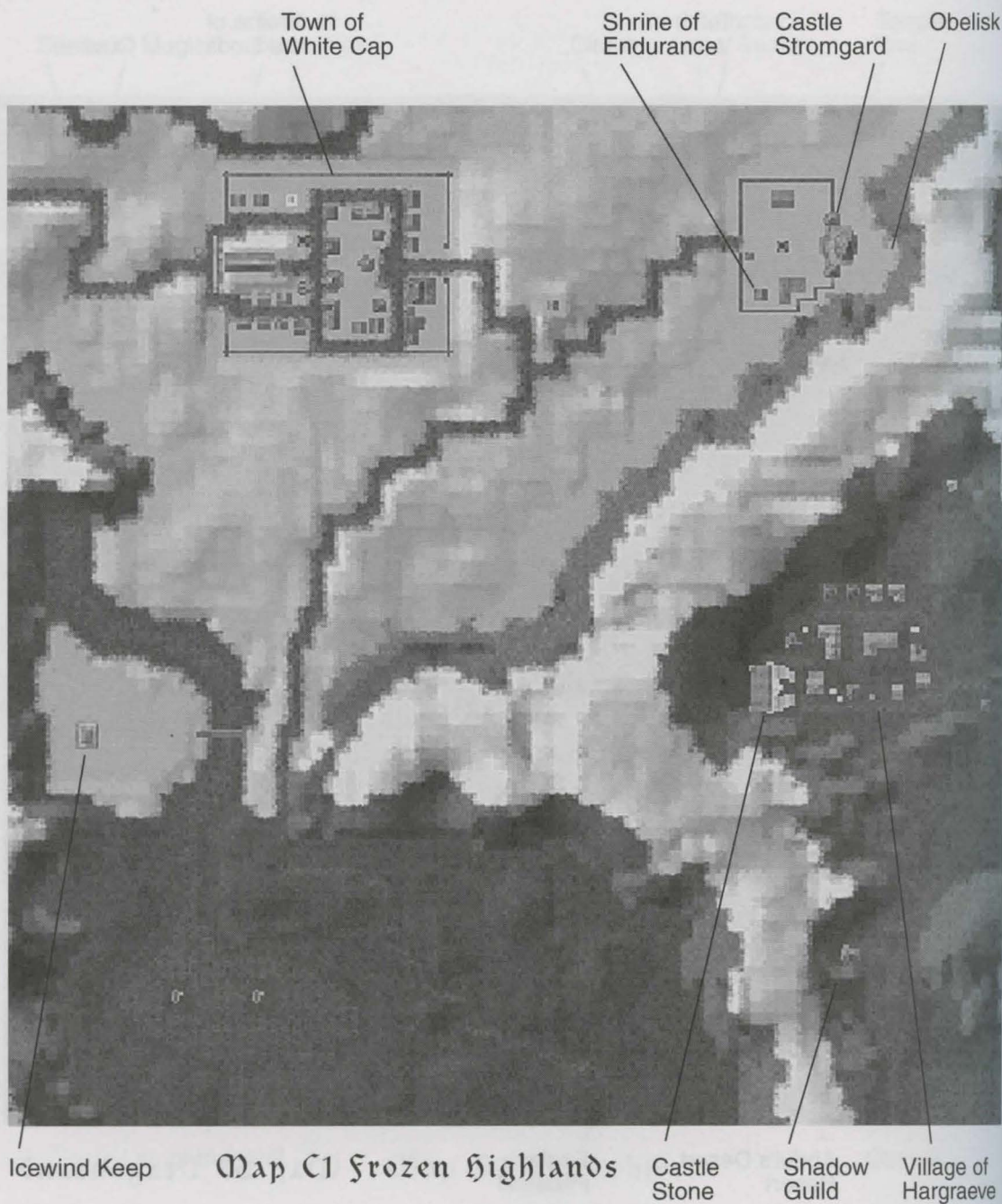

APPENDIX The Cartographer's Pantry:
Maps



Map C2 Free Haven



APPENDIX The Cartographer's Pantry:
Maps



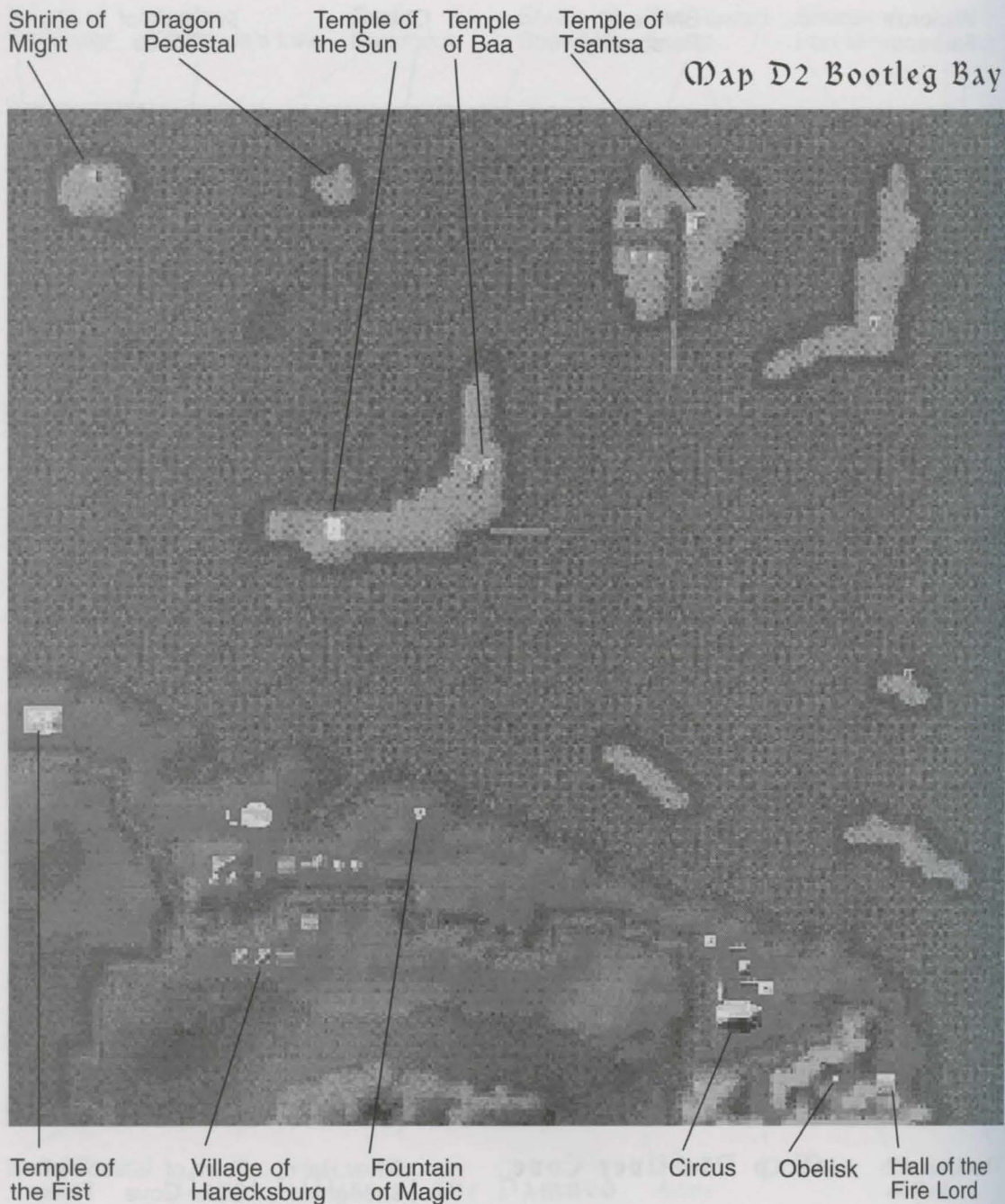

APPENDIX The Cartographer's Pantry: Maps

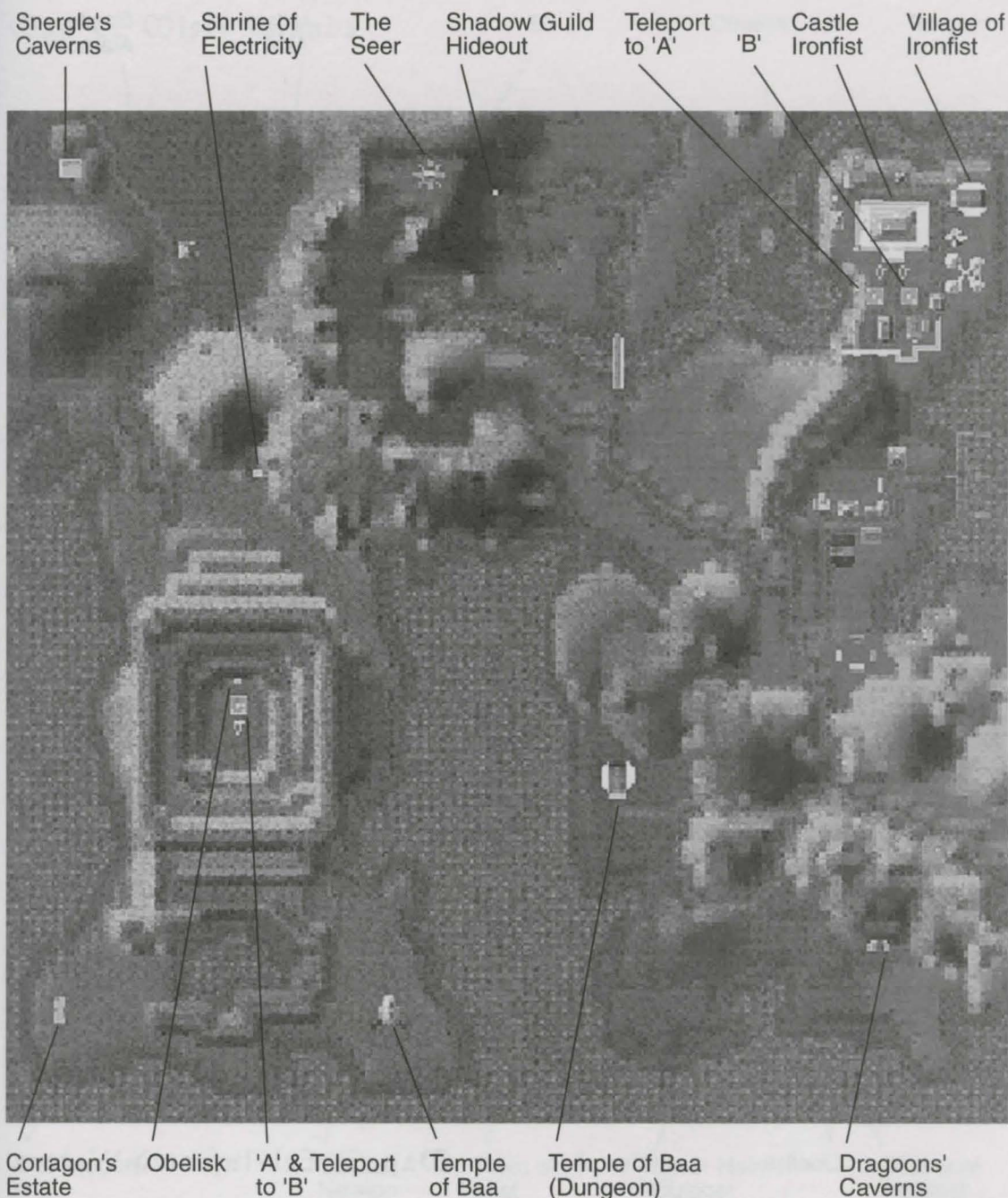

Map D3 Castle Ironfist

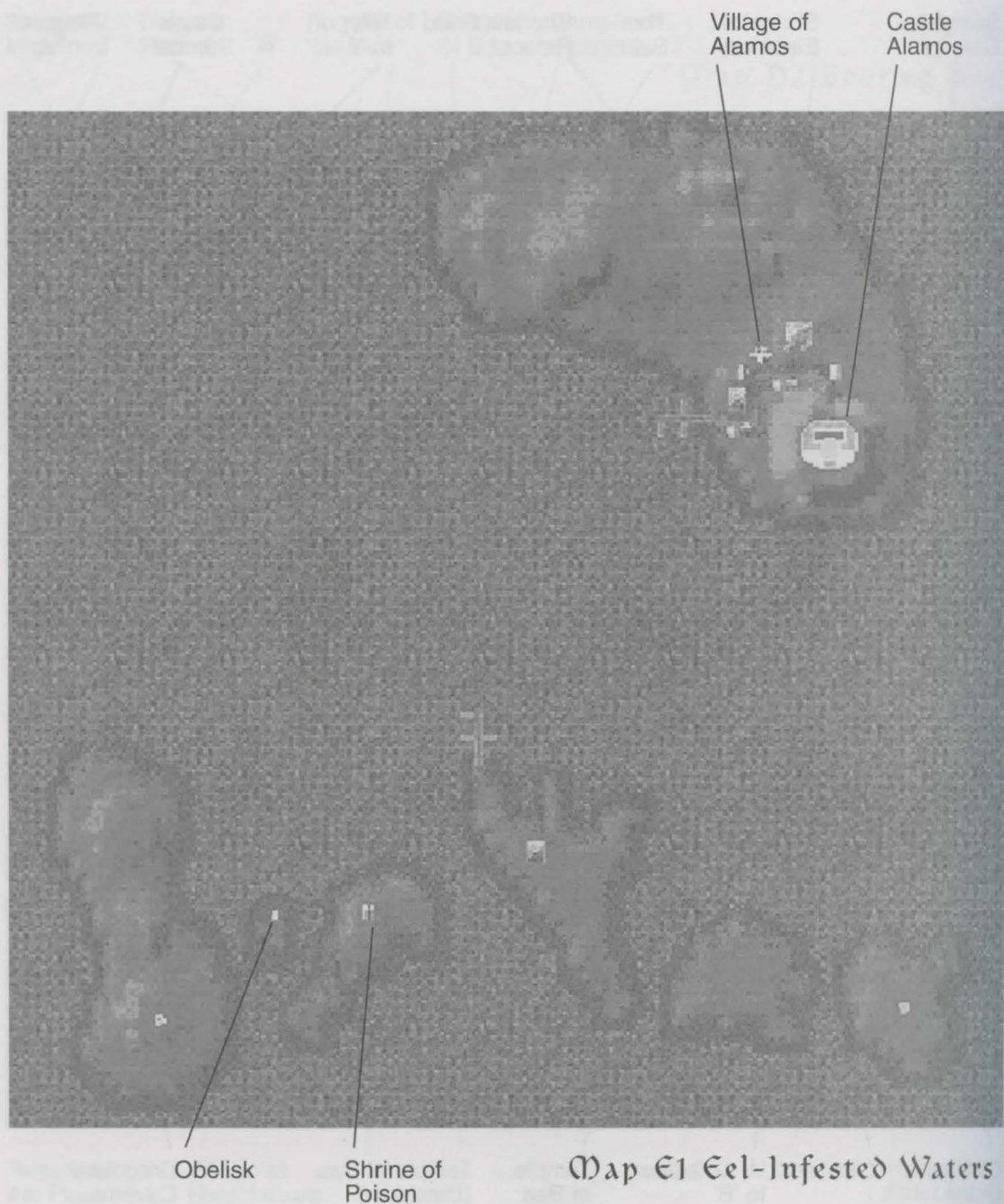

Map E1 Eel-Infested Waters

APPENDIX The Cartographer's Pantry:
Maps

Map E2 Misty Islands

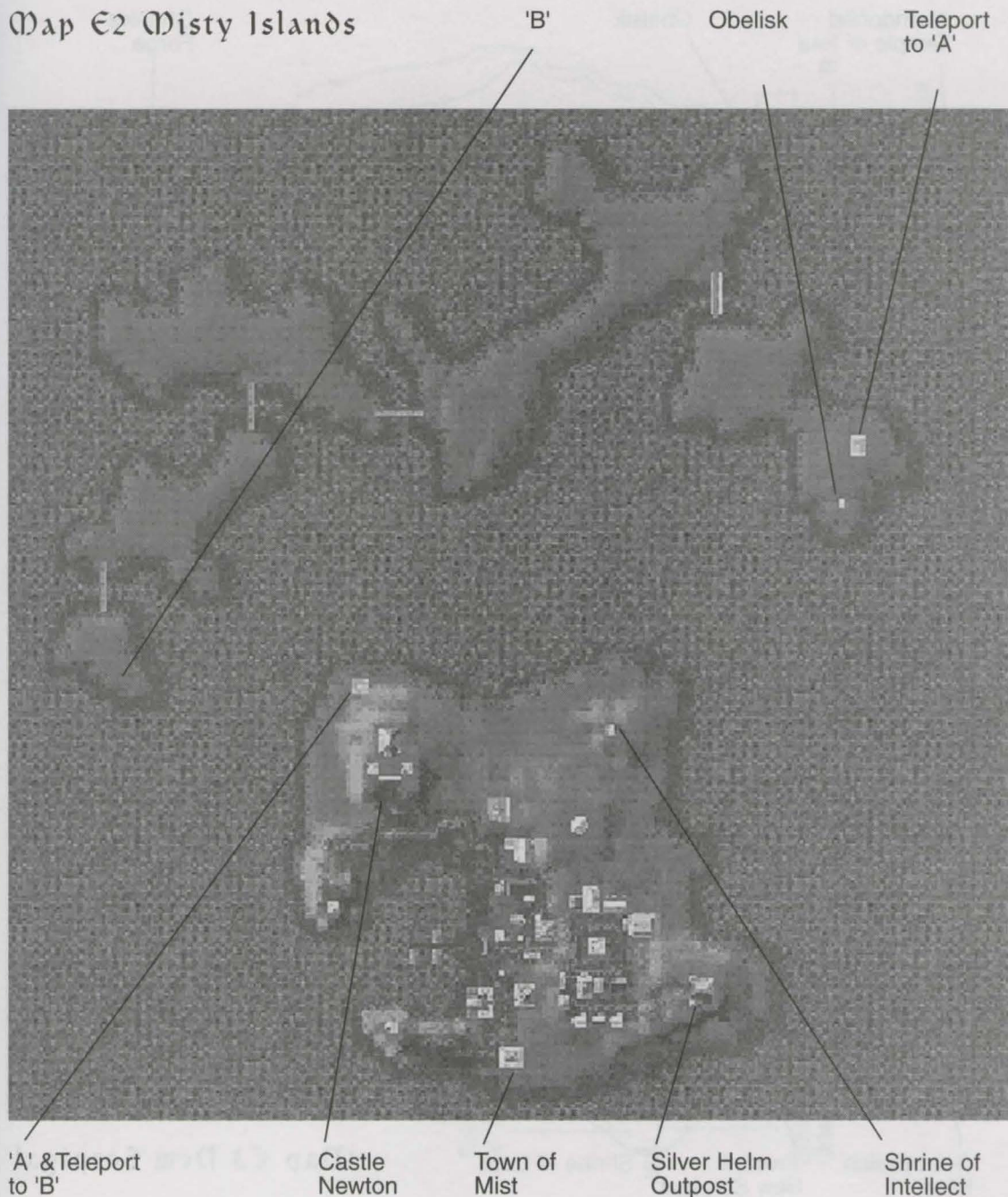

MIHT & MAGIC VI The Mandate of Heaven
Official Strategy Guide

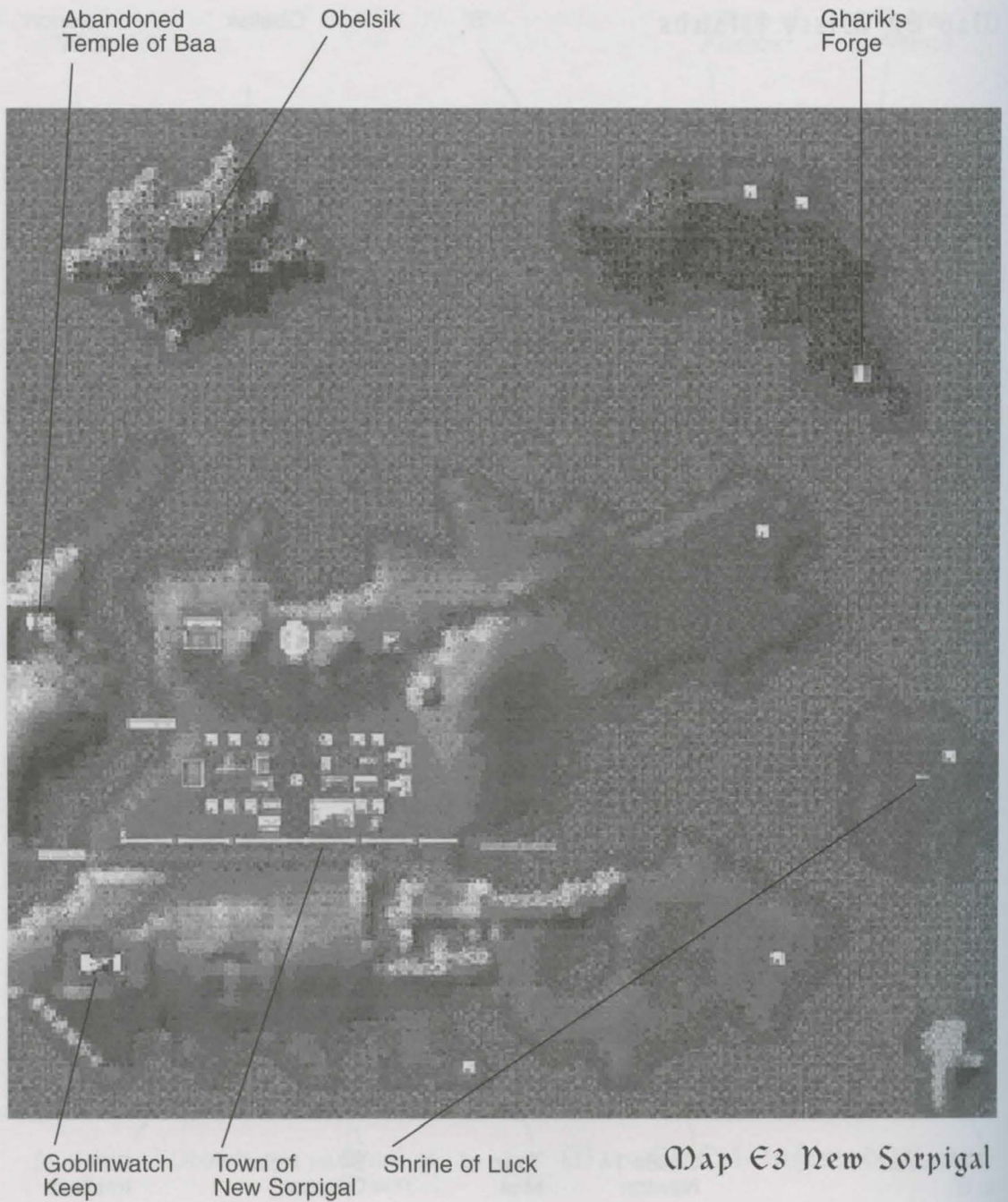

Abandoned Temple of Baa

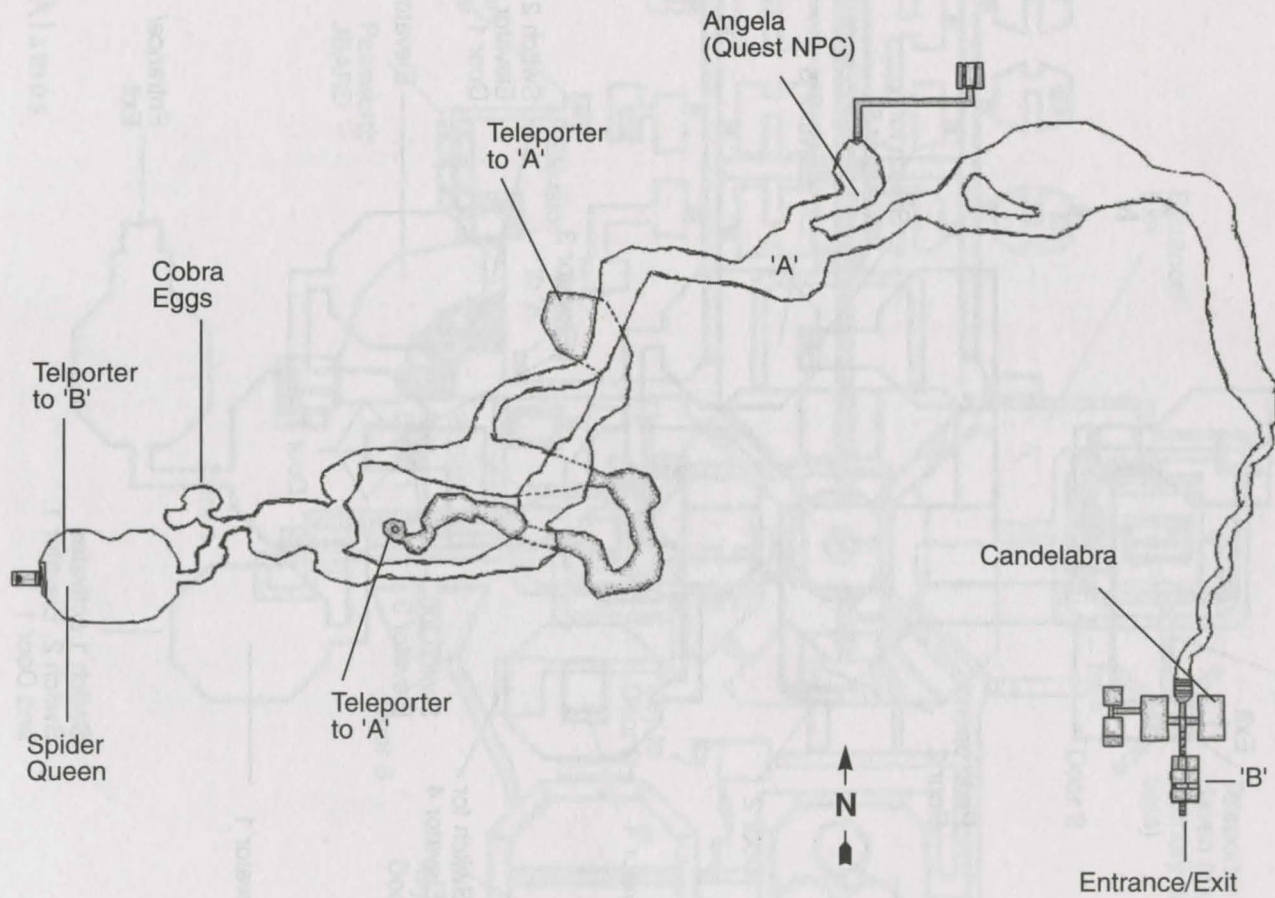

CHAPTER 7 The Pros and Cons
of NPCs in Your Party

Agar's Laboratory

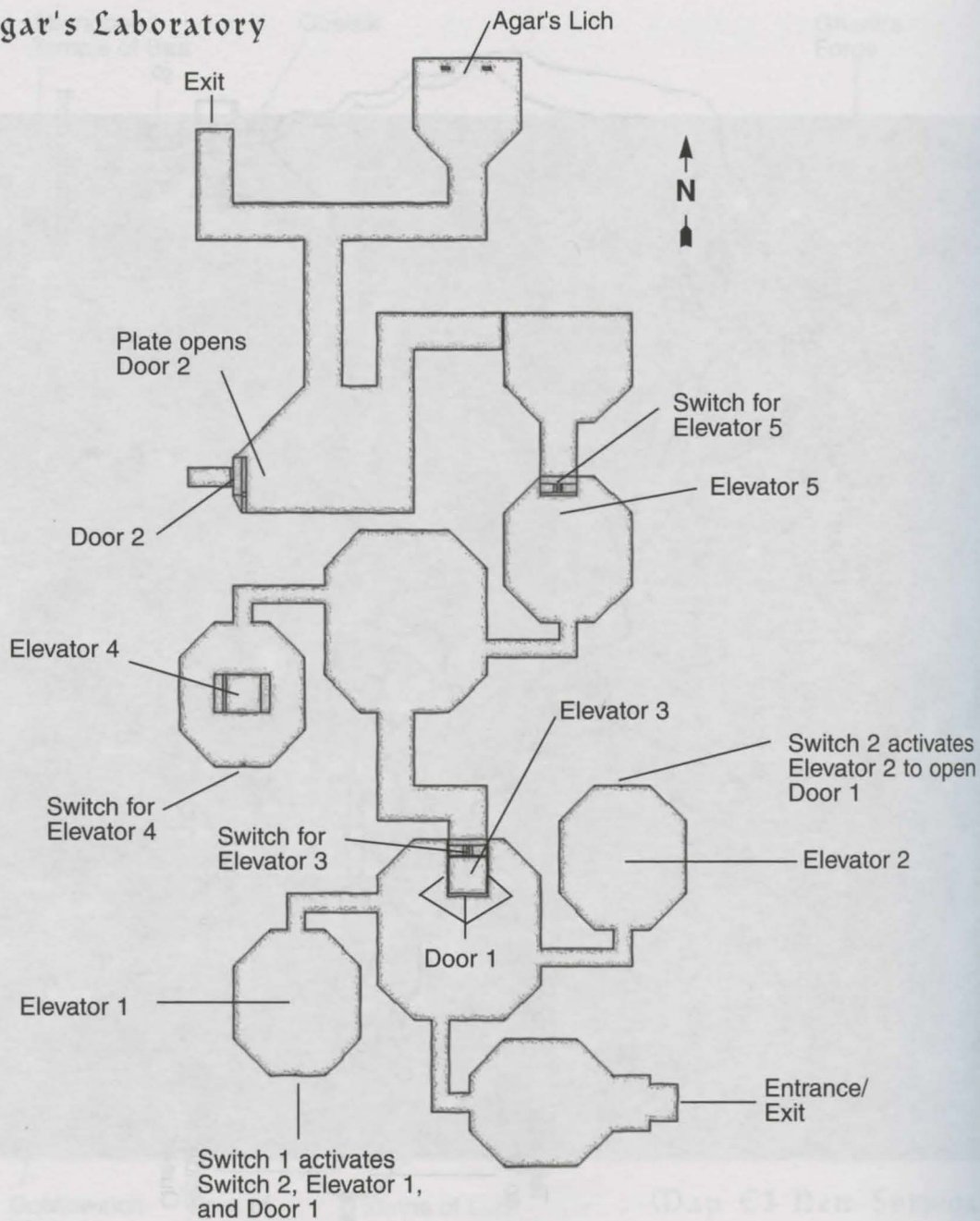

APPENDIX The Cartographer's Pantry:
Maps

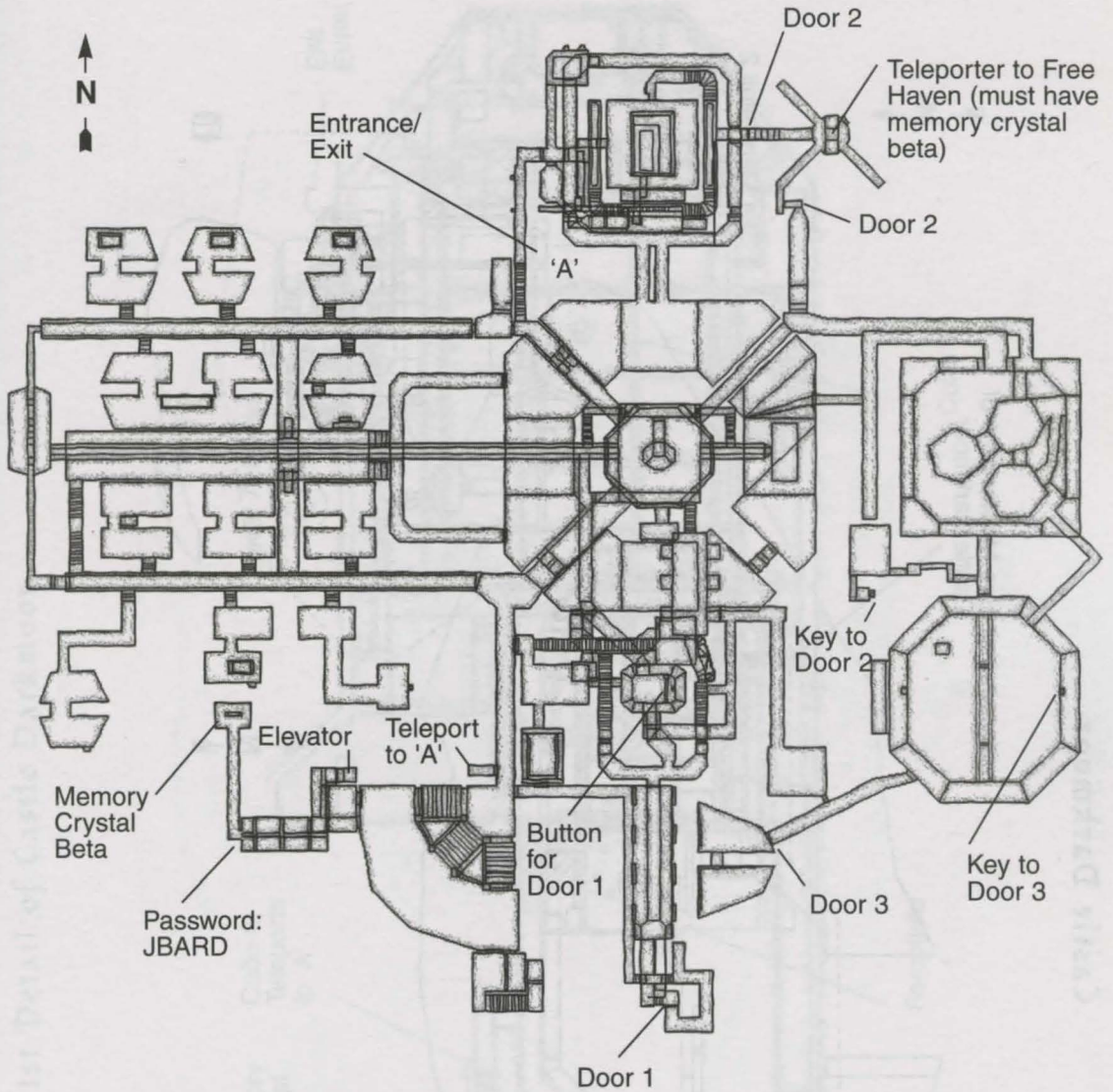

Castle Darkmoor

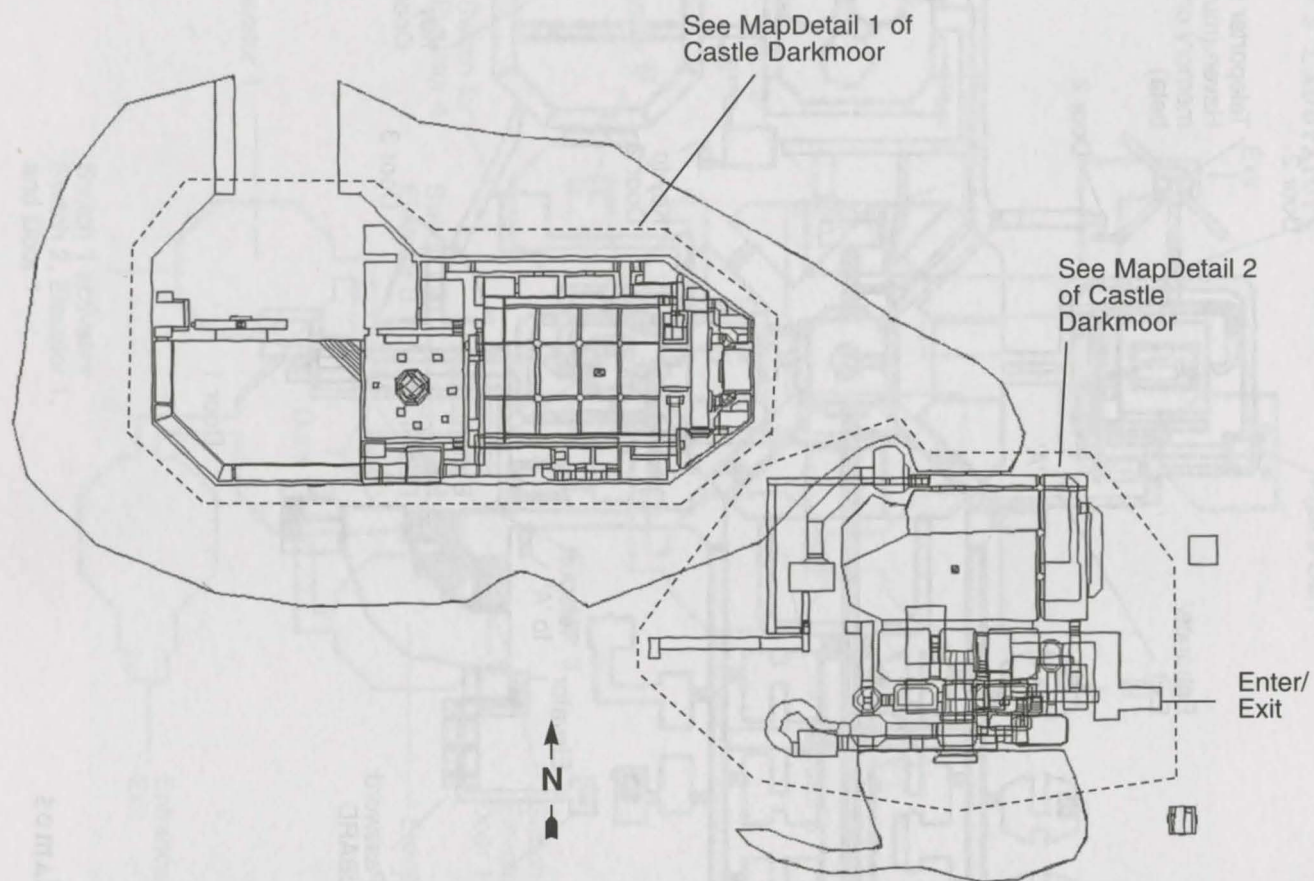

1st Detail of Castle Darkmoor

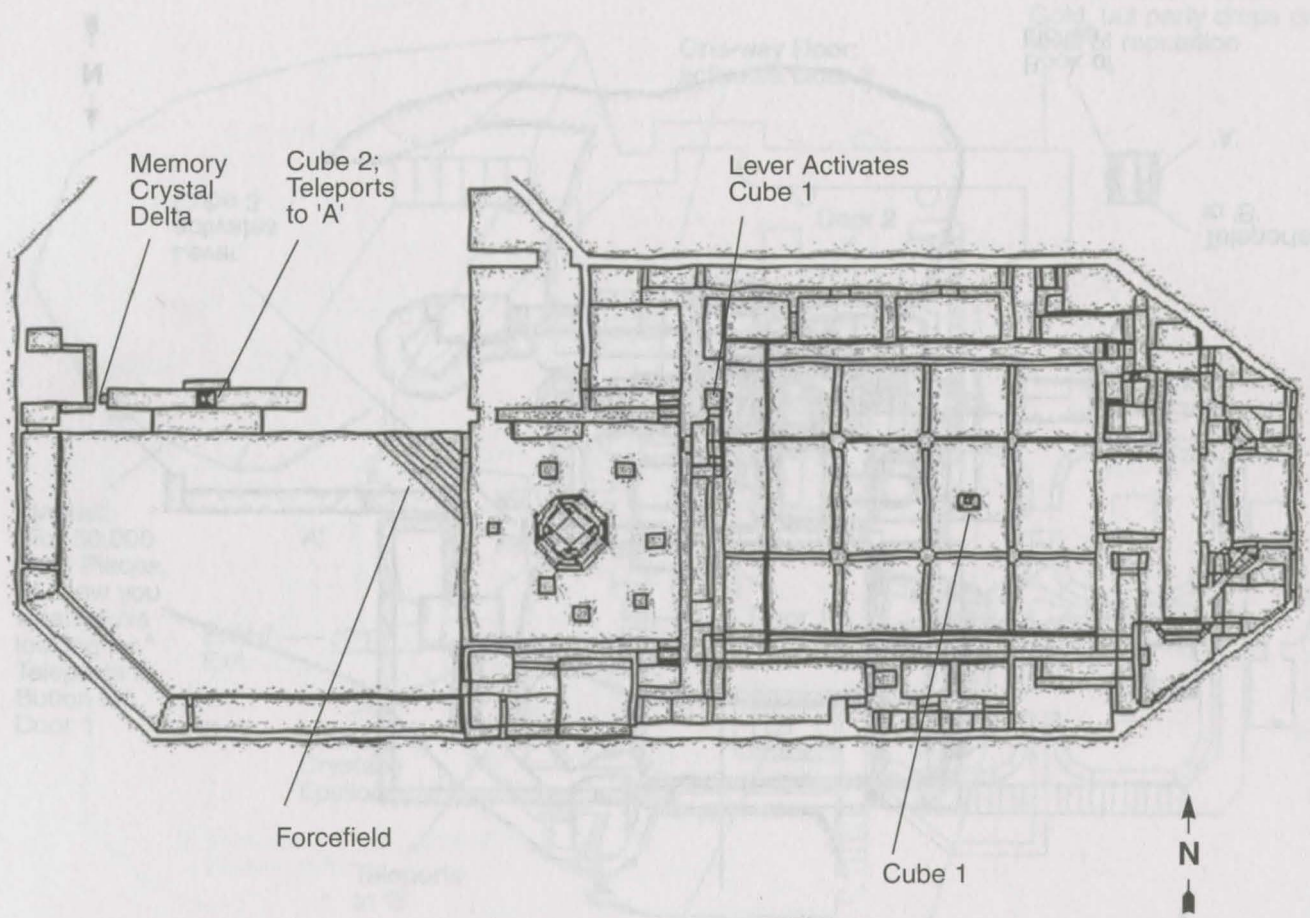

2nd Detail of Castle Darkmoor

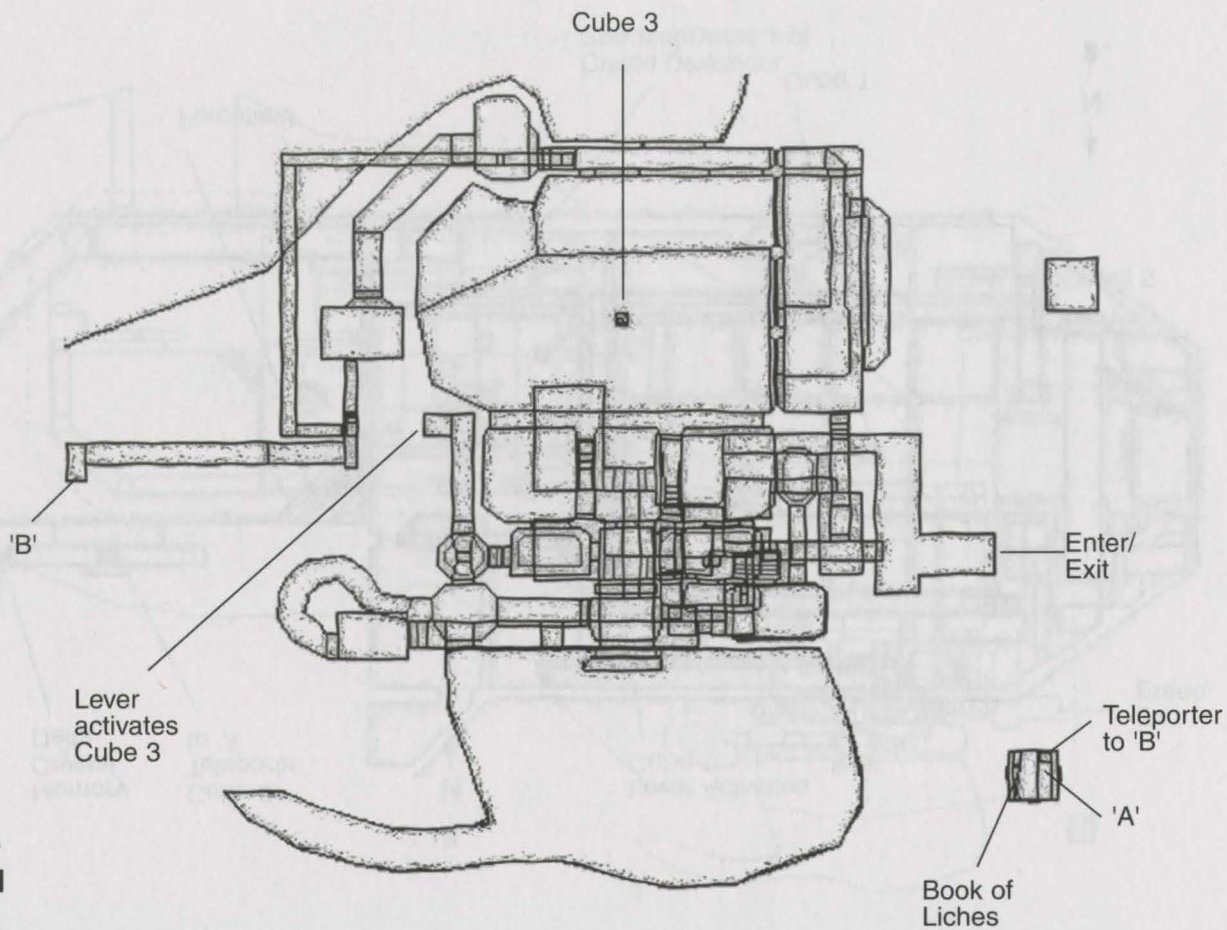

Castle Kriegspire

Reaper Plaque will heal entire party's Hit Points & conditions for 10,000 Gold, but party drops one level of reputation

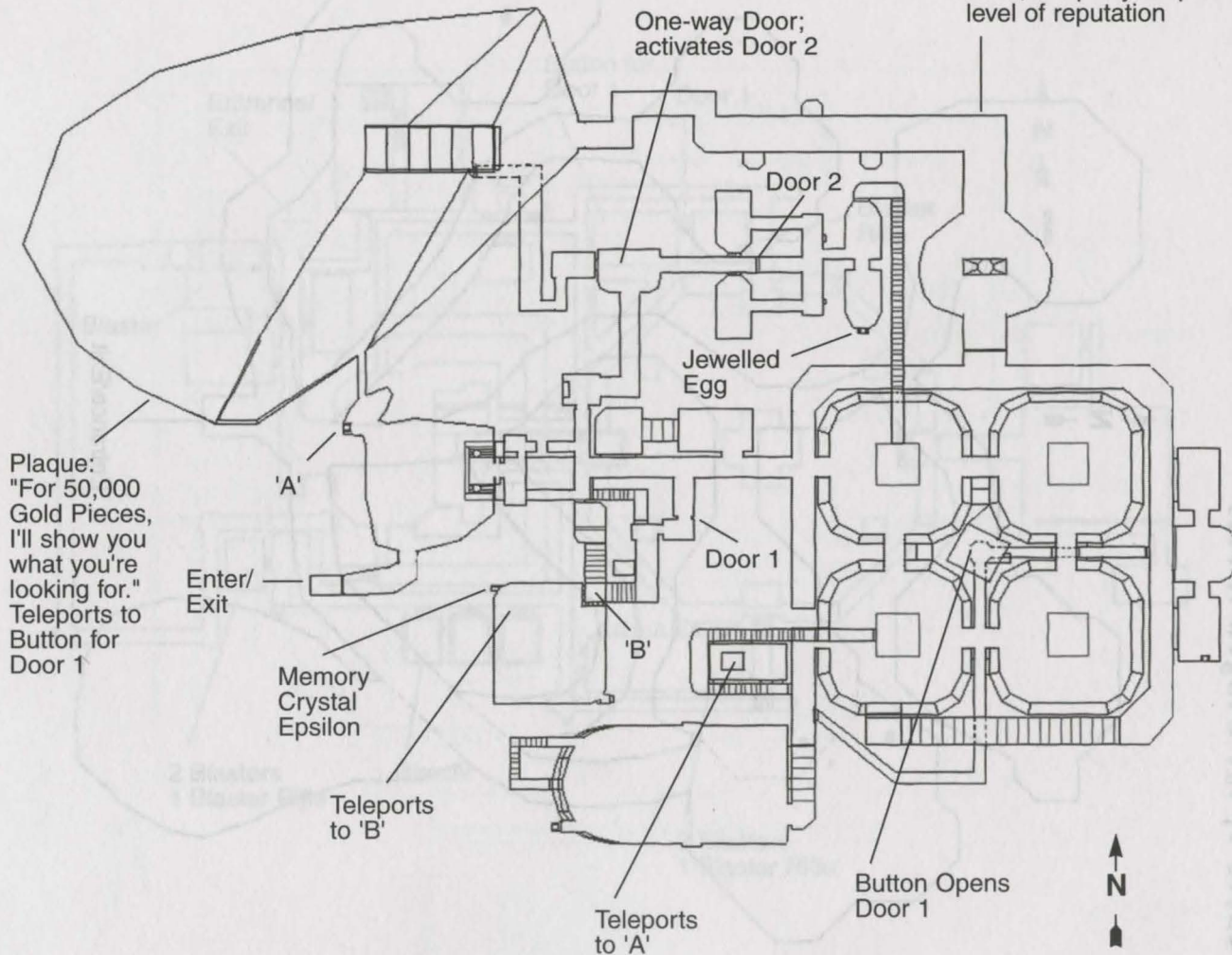

Caves of the Dragon Riders

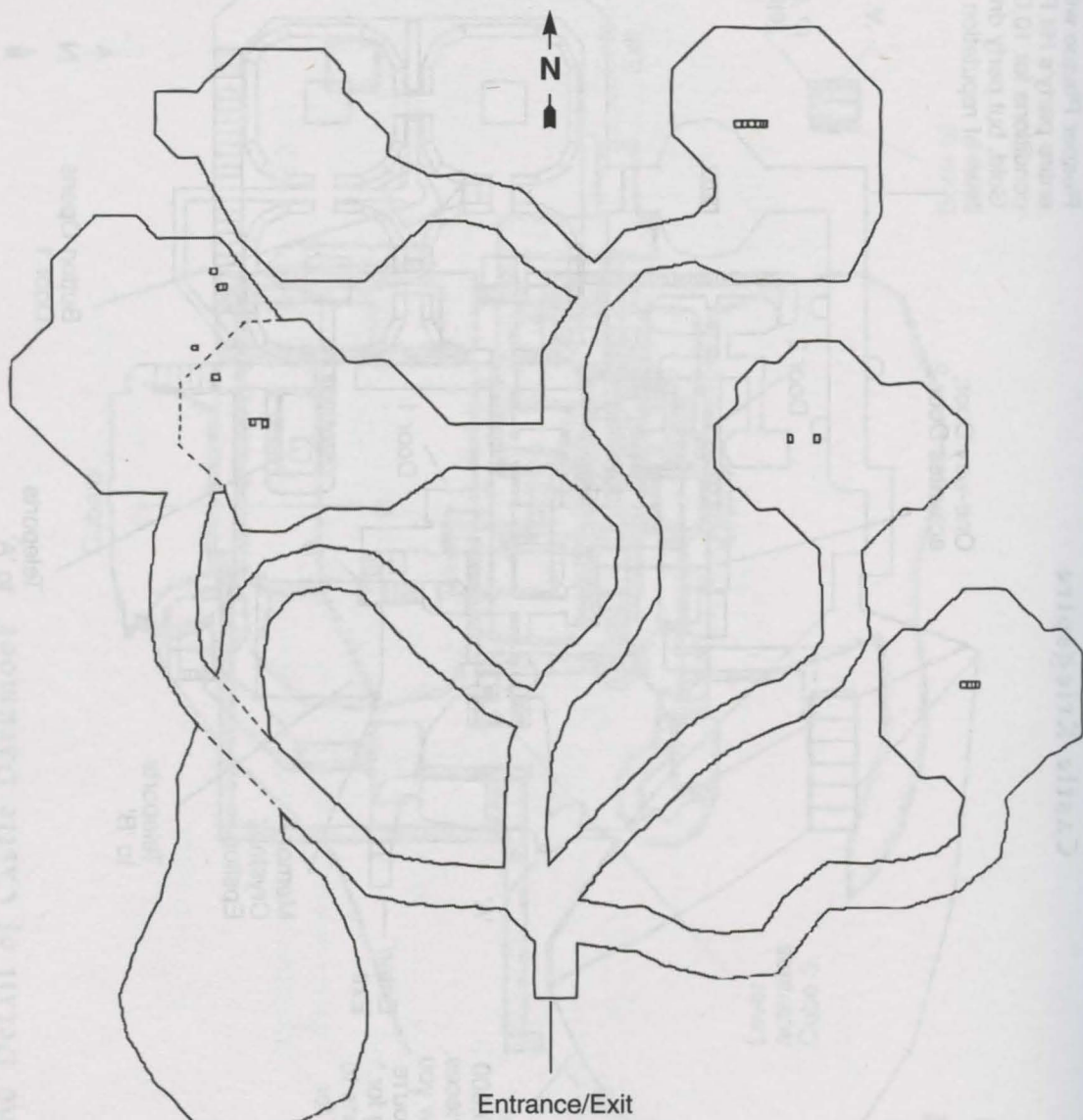

Control Center, Level 1

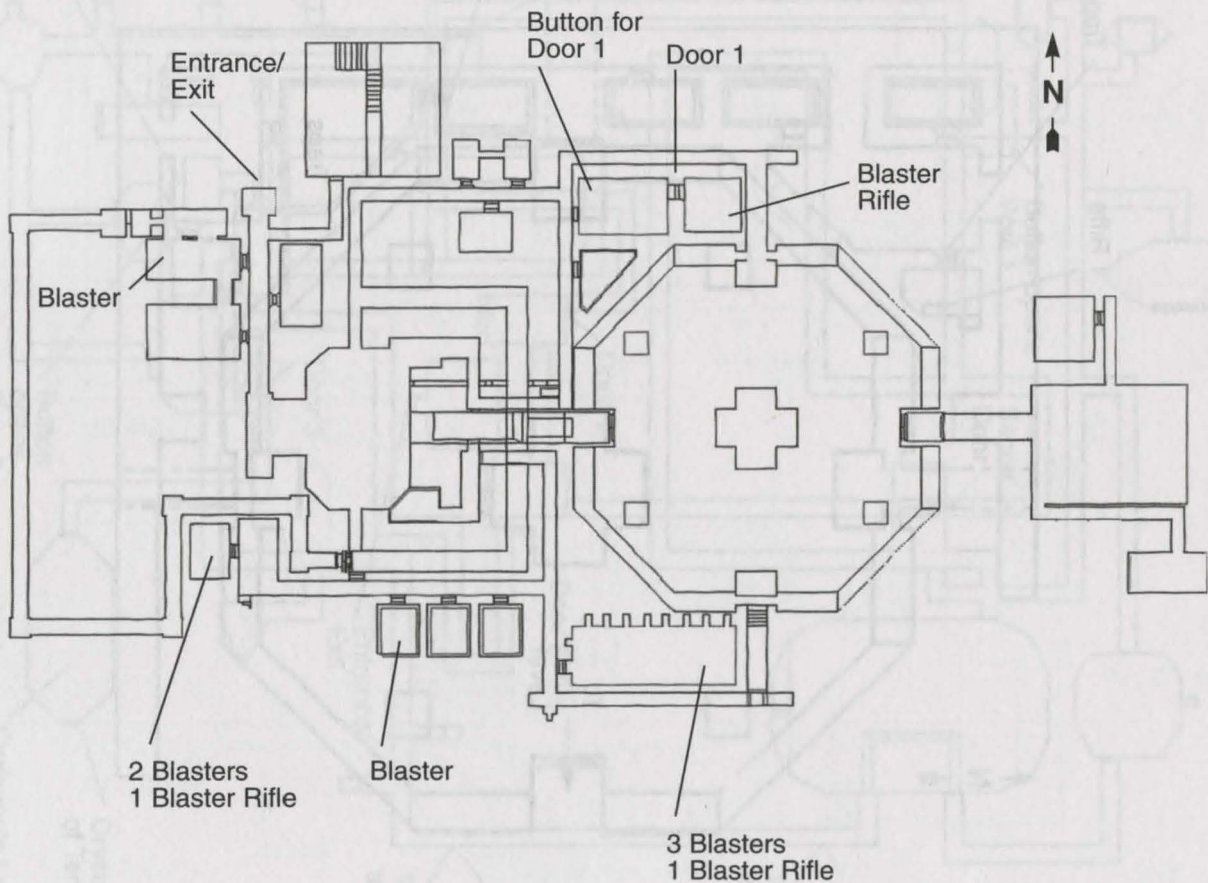

Control Center, Level 2

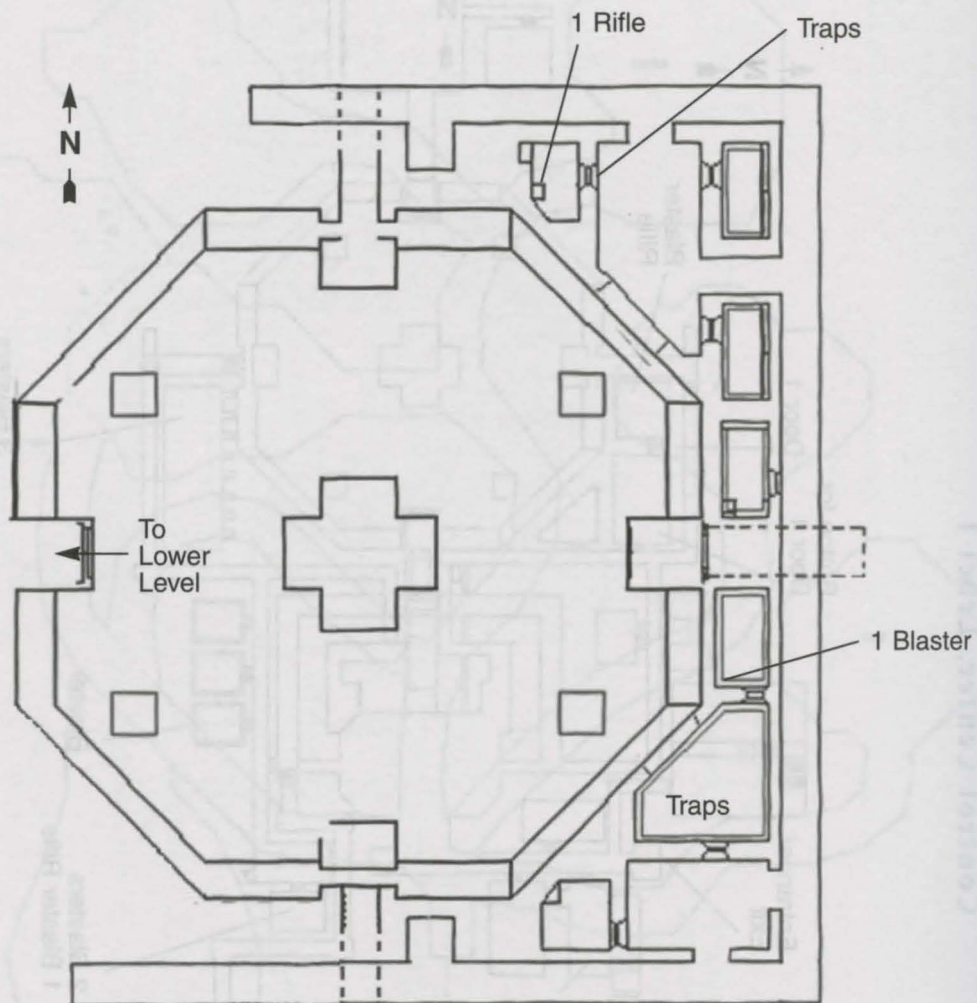

APPENDIX The Cartographer's Pantry:
Maps

Corlagon's Estate

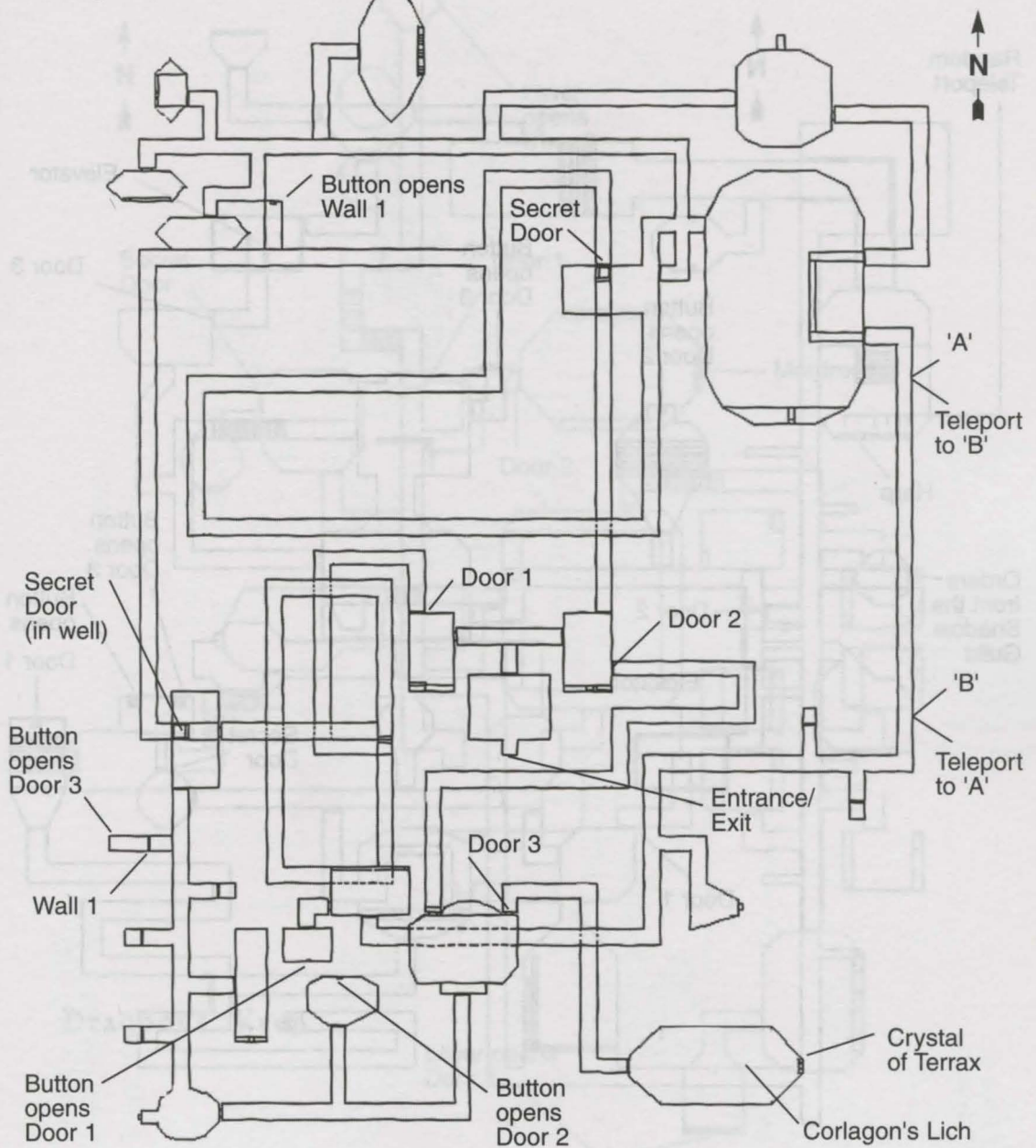

Dragoons Caverns

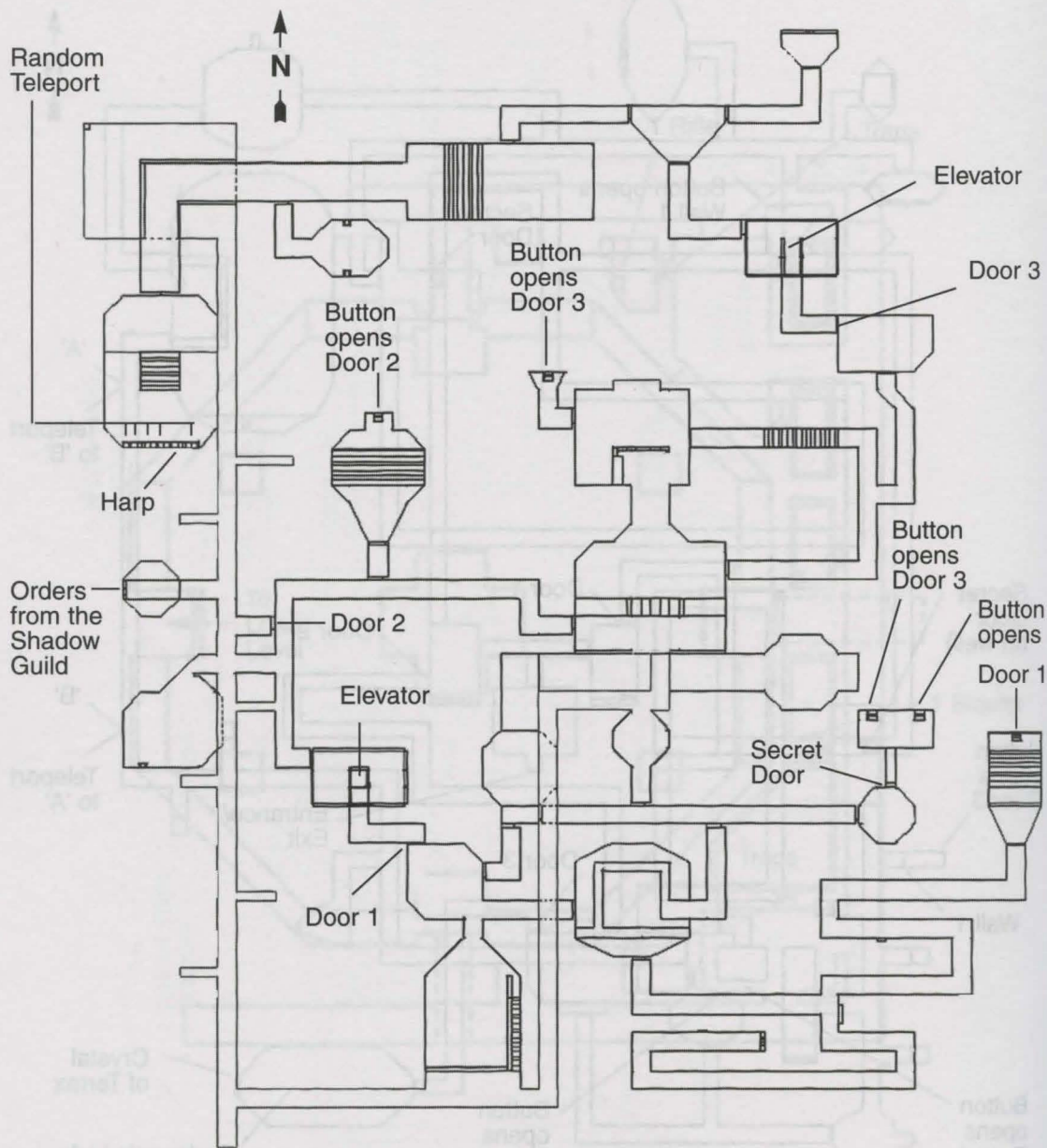

APPENDIX The Cartographer's Pantry: Maps

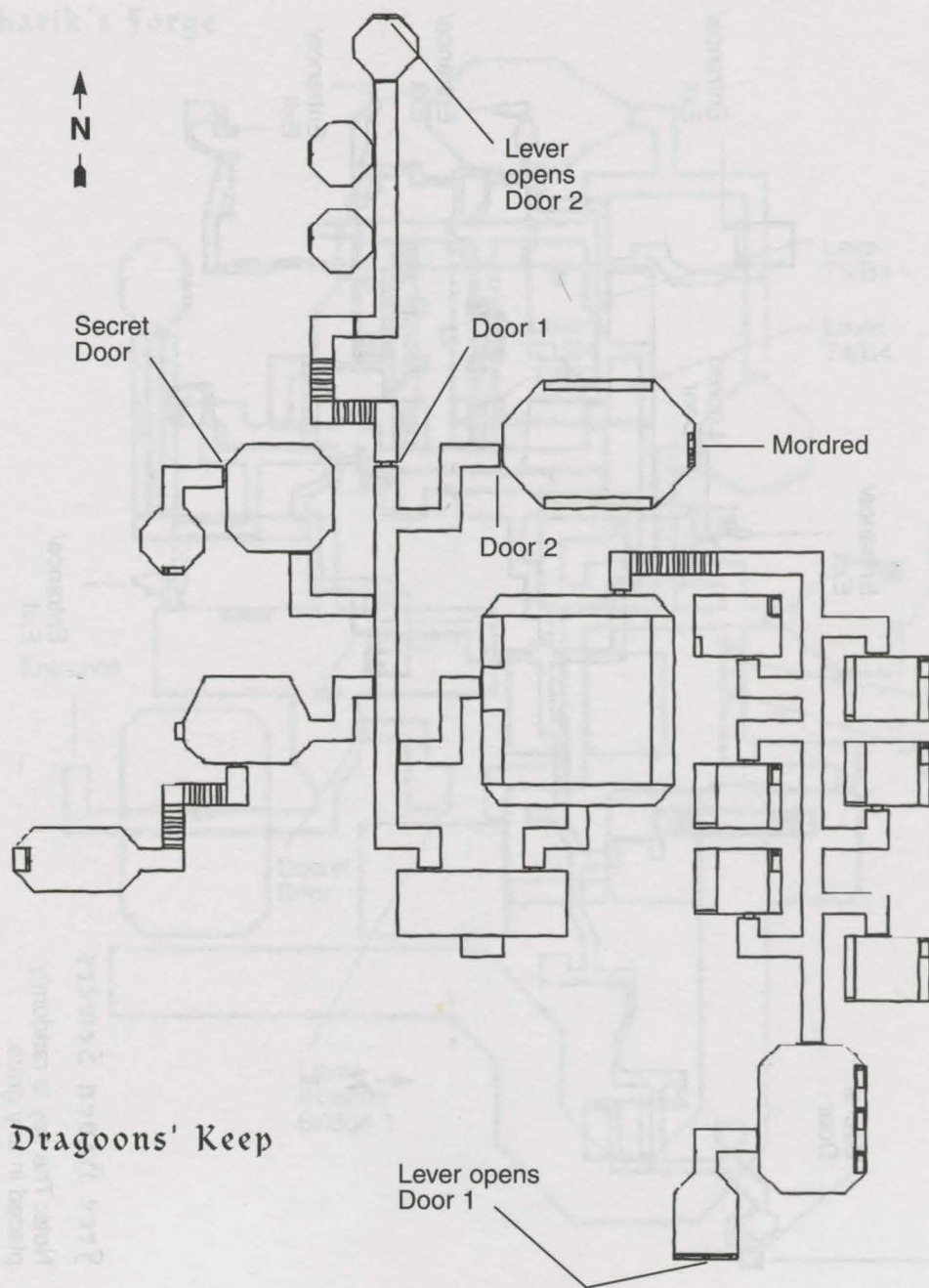

Prince of Thieves

Secret Door

Entrance/
Exit

Locked Door

Entrance/
Exit

Entrance/
Exit

Entrance/
Exit

Entrance/
Exit



Free Haven Sewers

Note: The key is randomly placed in any grate.

APPENDIX The Cartographer's Pantry:
Maps

Gharik's Forge

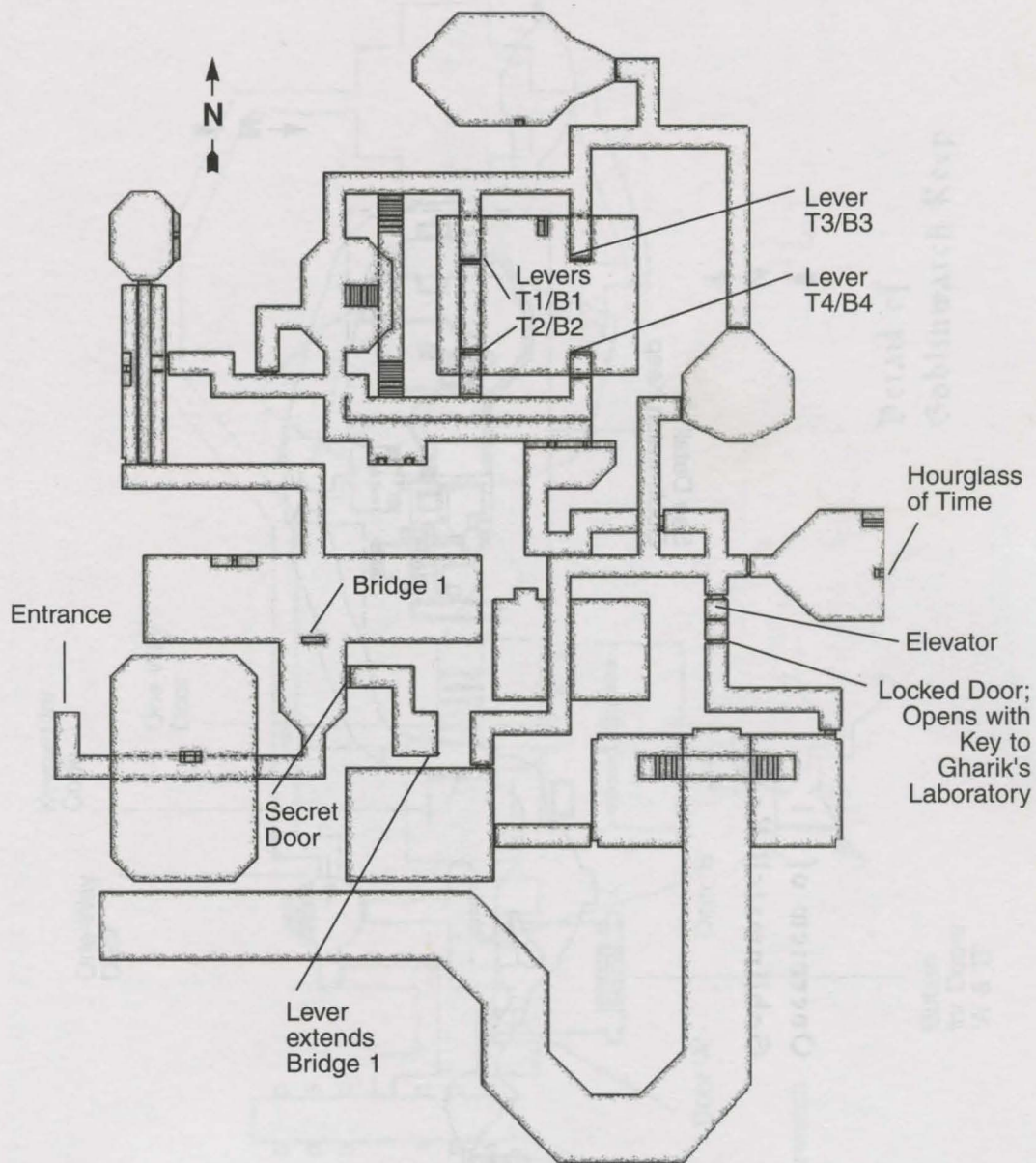

Overview of Goblinwatch Keep

See Detail of
Goblinwatch Keep

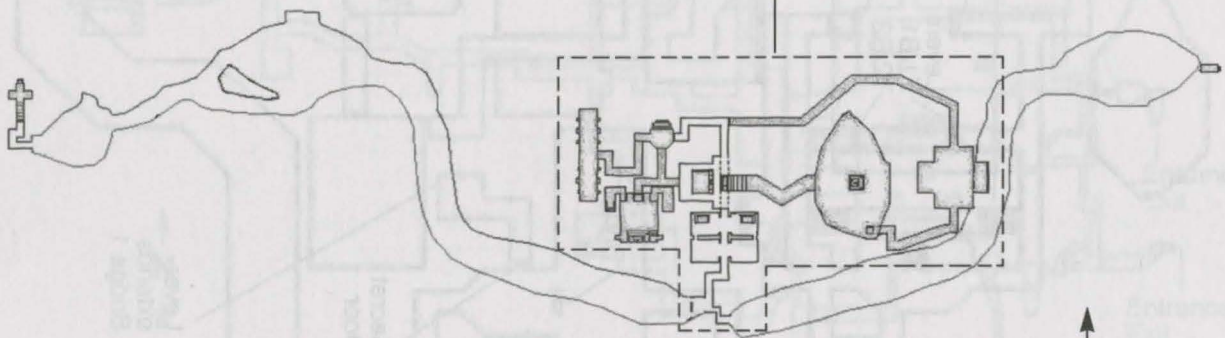

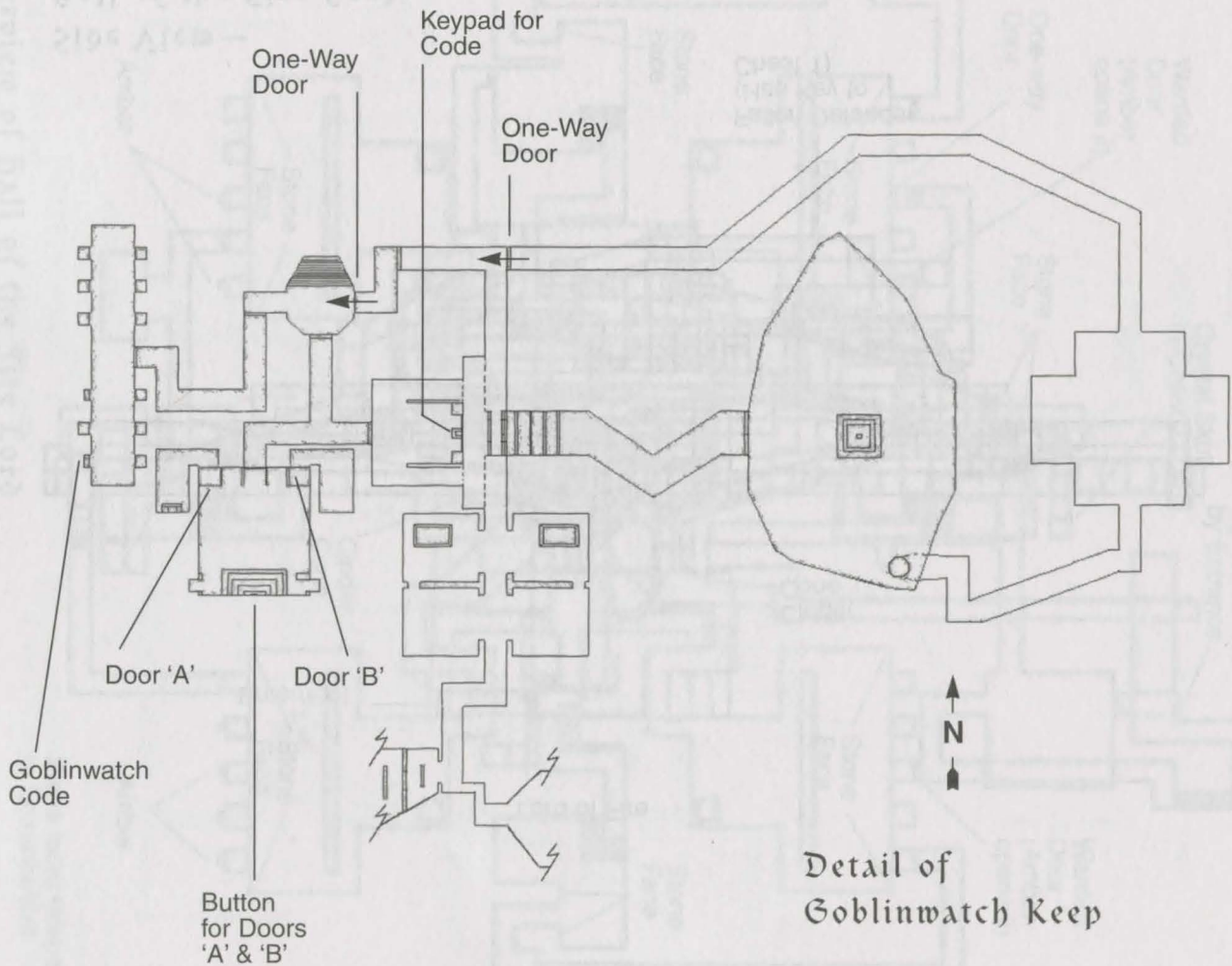

Detail of
Goblinwatch Keep

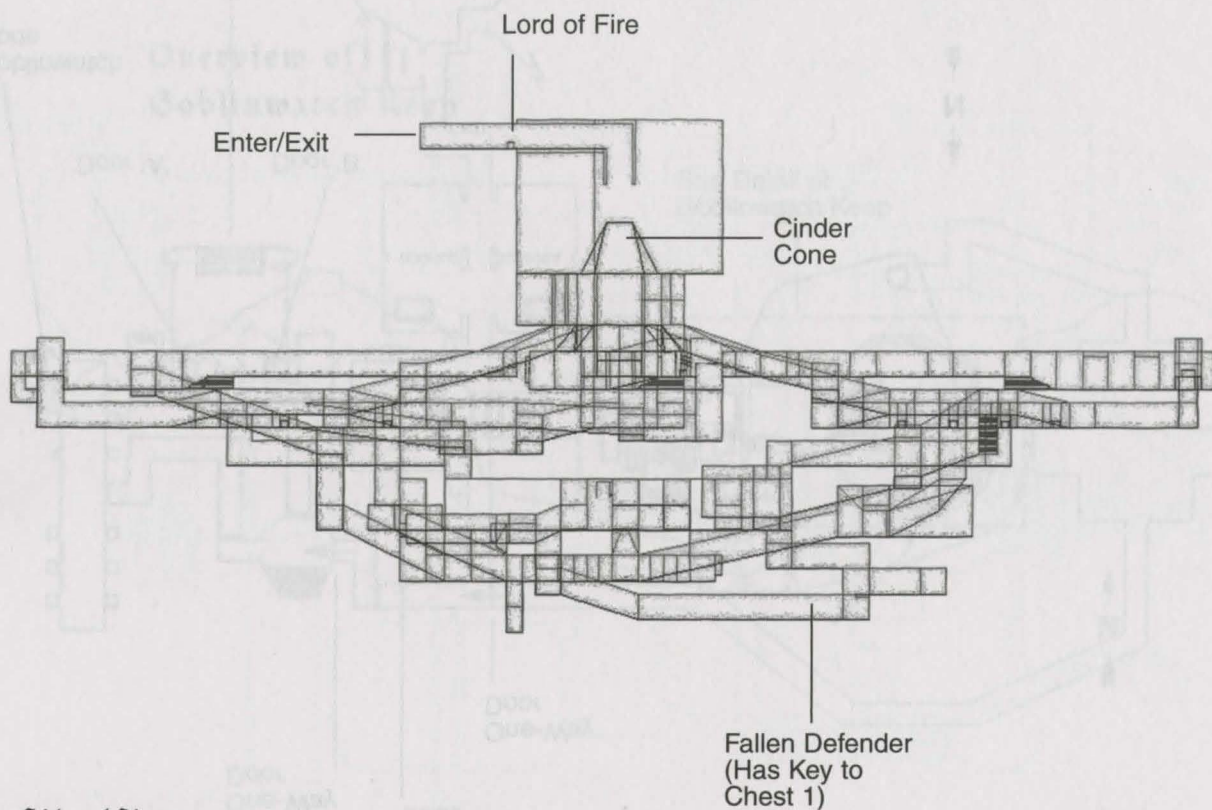

Side View—
Hall of the Fire Lord

APPENDIX The Cartographer's Pantry:
Maps

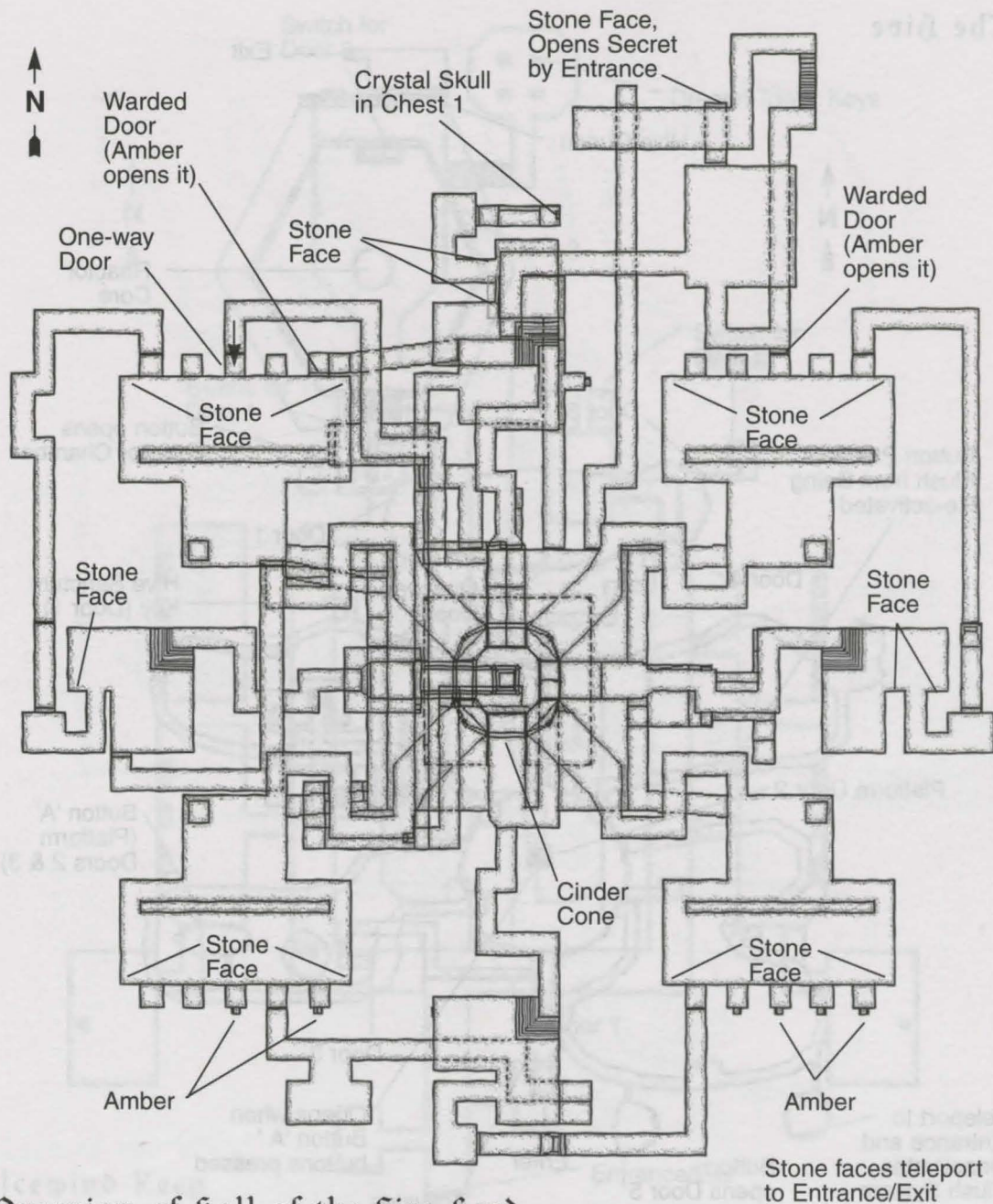

Overview of Hall of the Fire Lord

The Hive

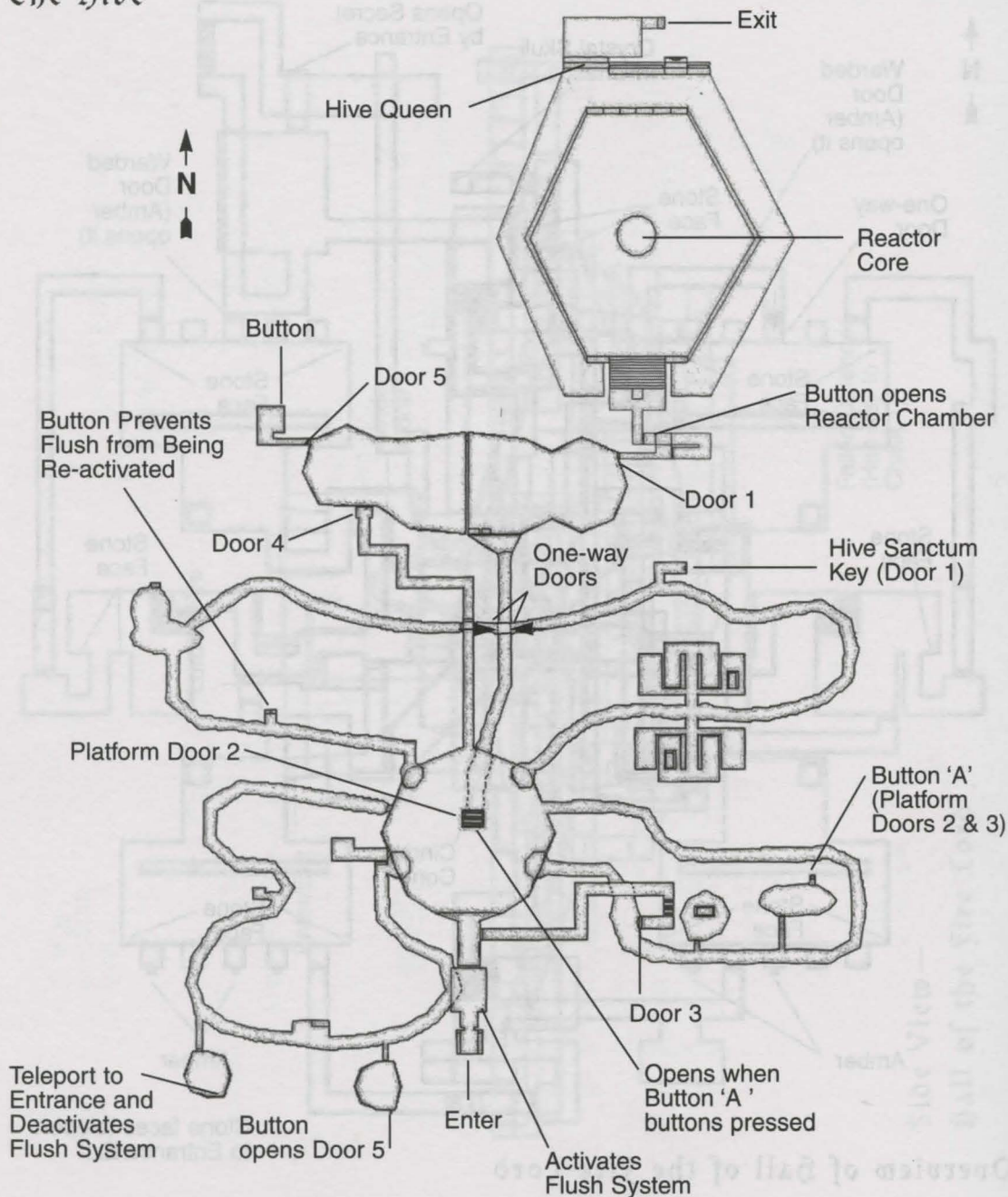

APPENDIX The Cartographer's Pantry:
Maps

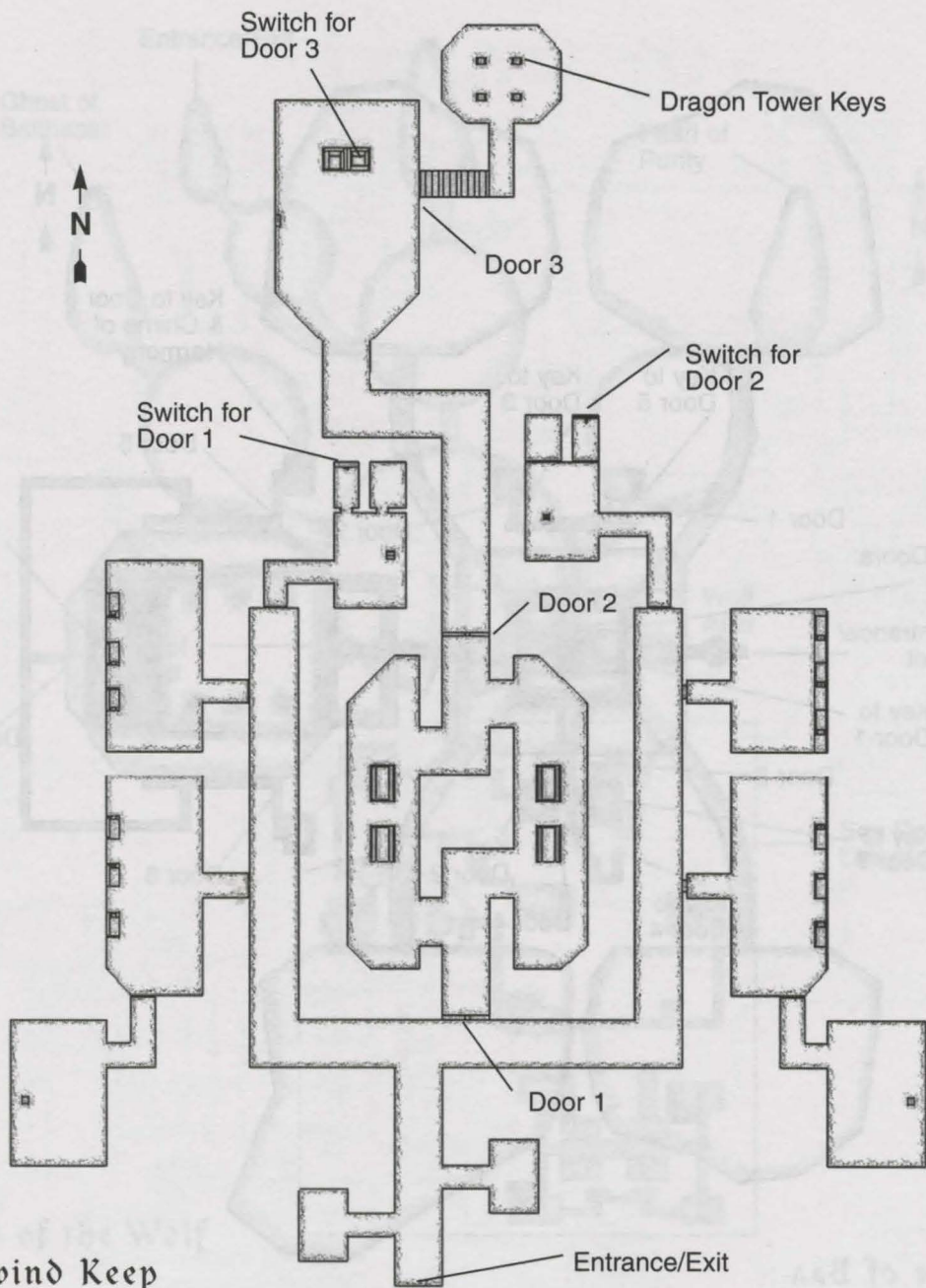

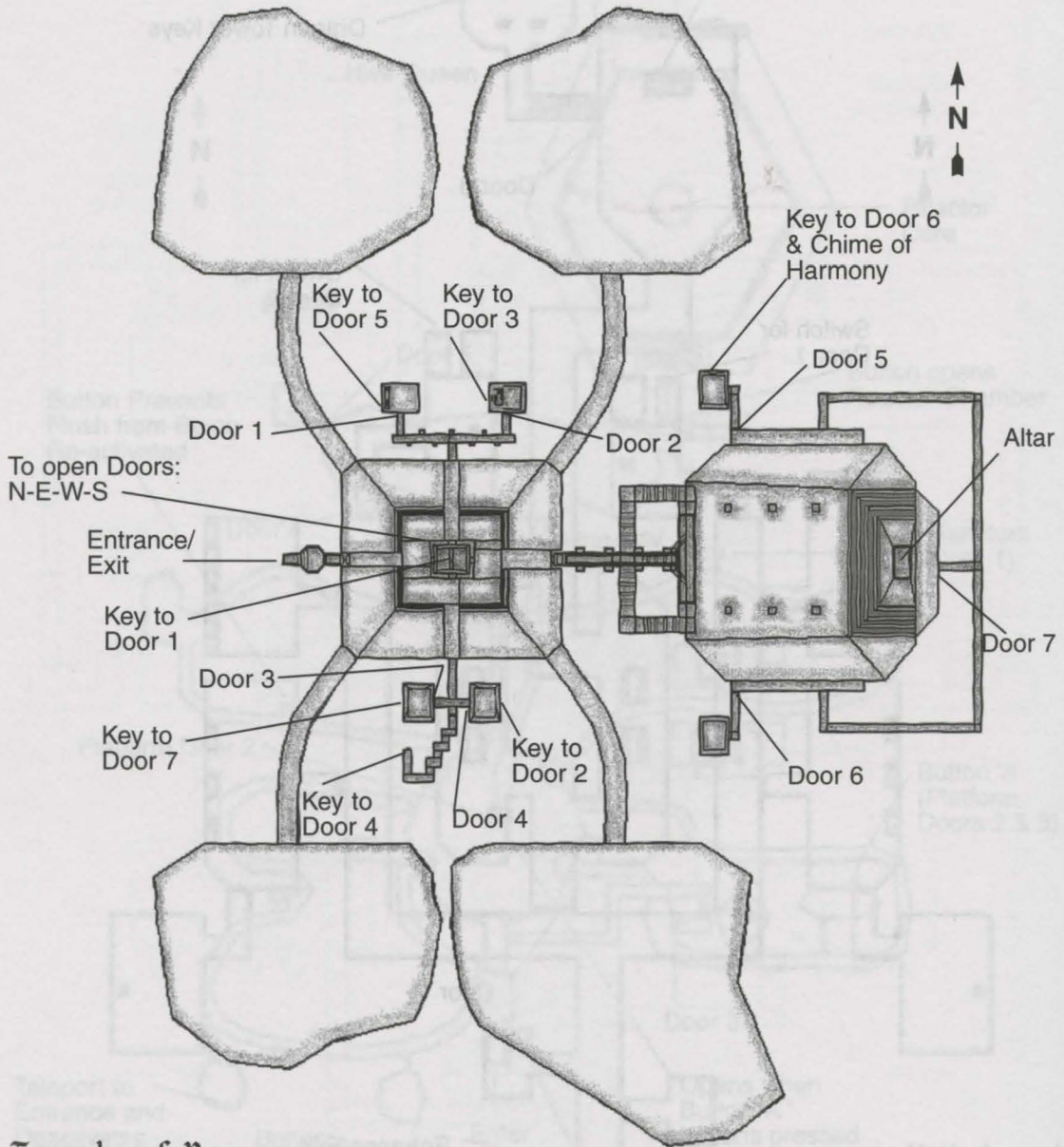

Temple of Baa

APPENDIX The Cartographer's Pantry:
Maps

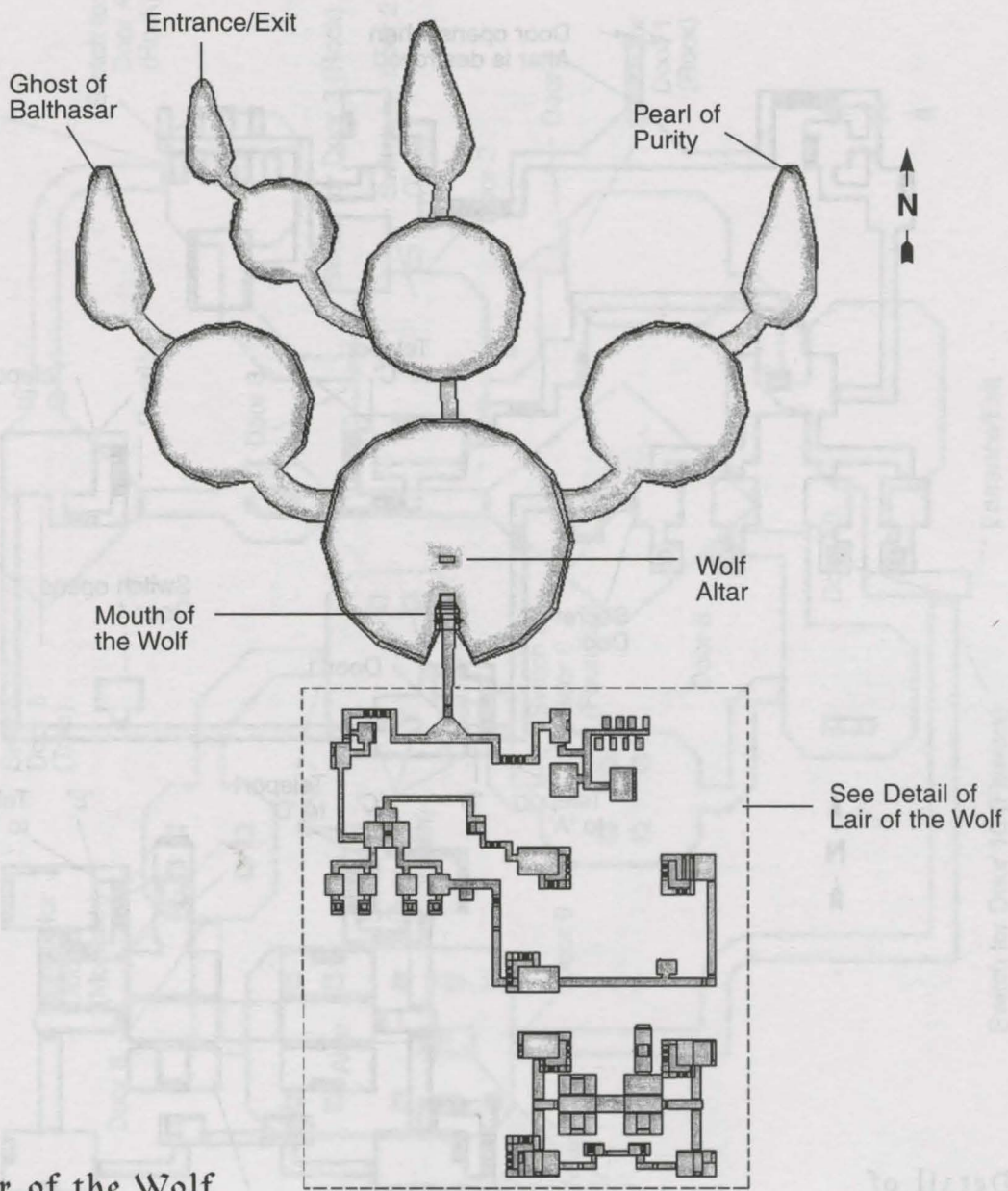

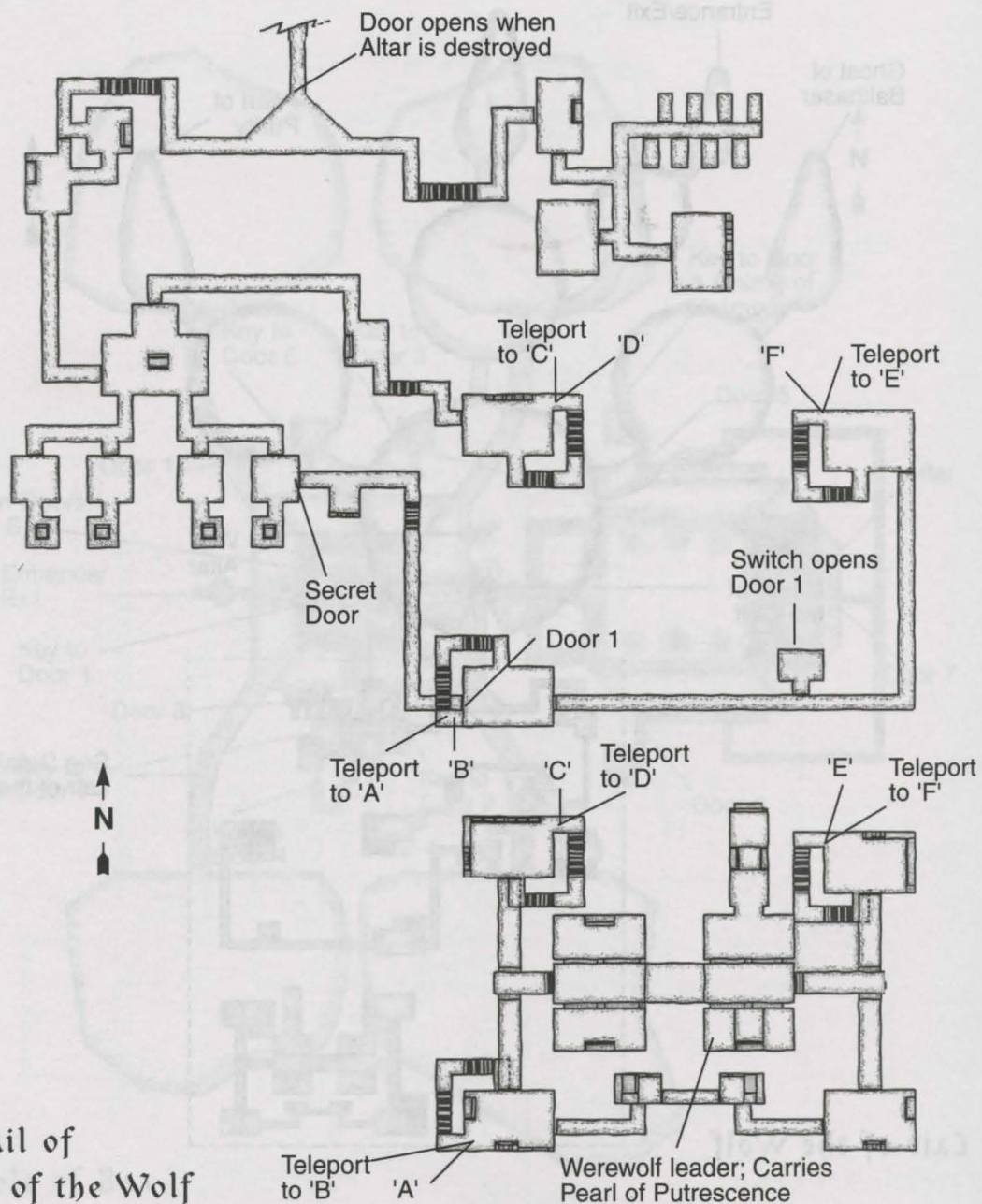

Detail of
Lair of the Wolf

The Monolith

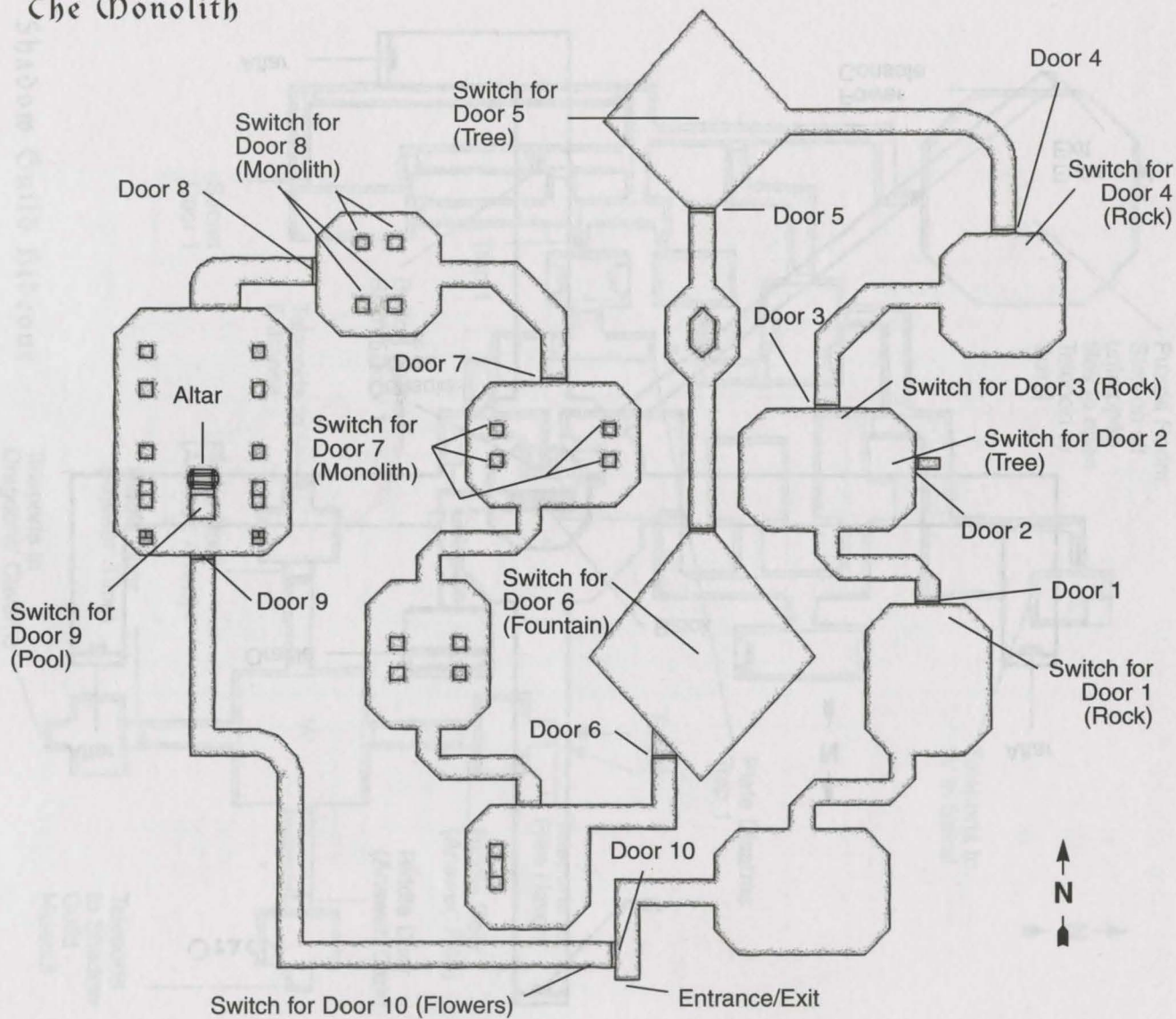

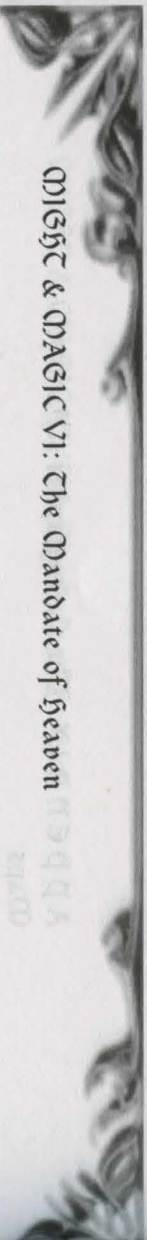
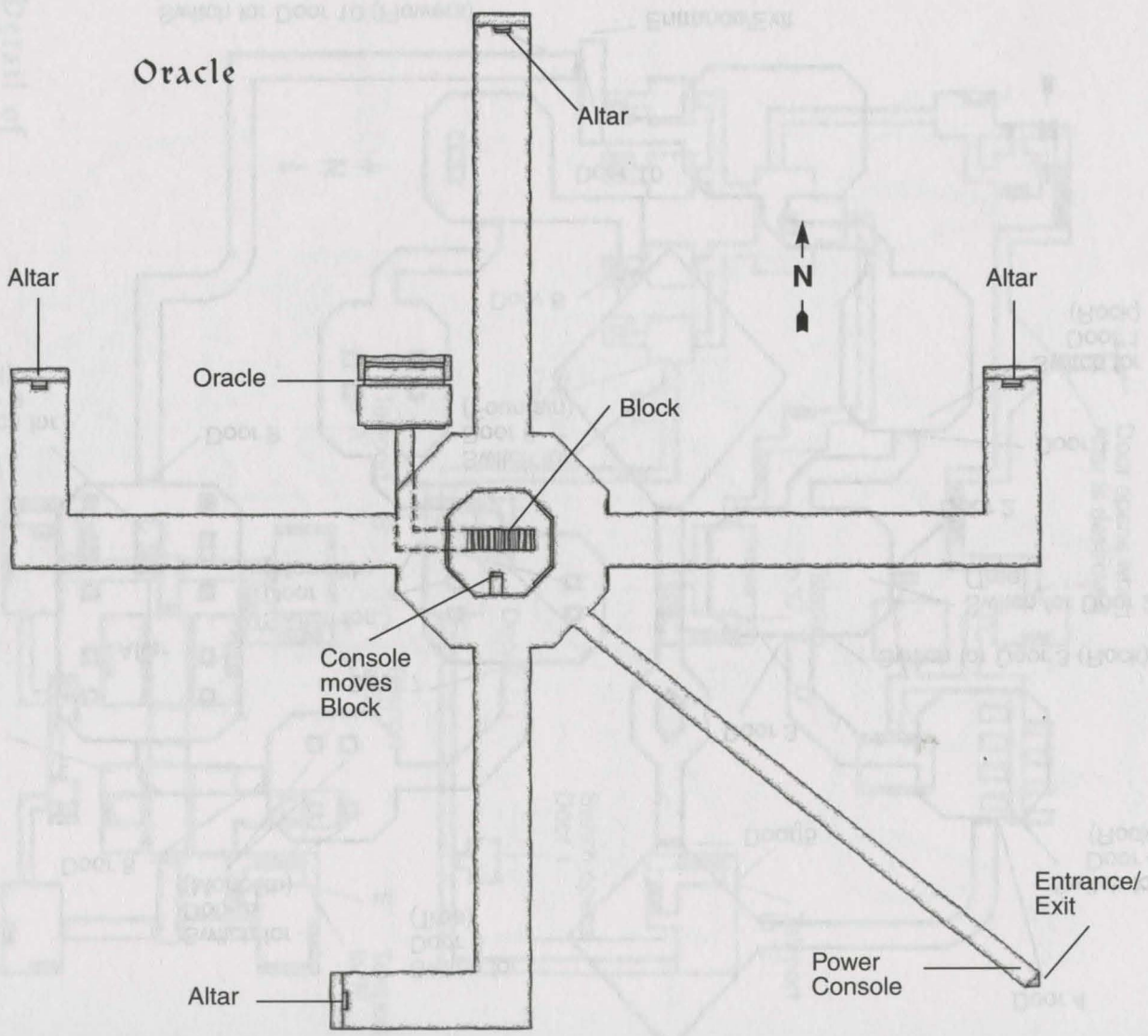

APPENDIX The Cartographer's Pantry: Maps

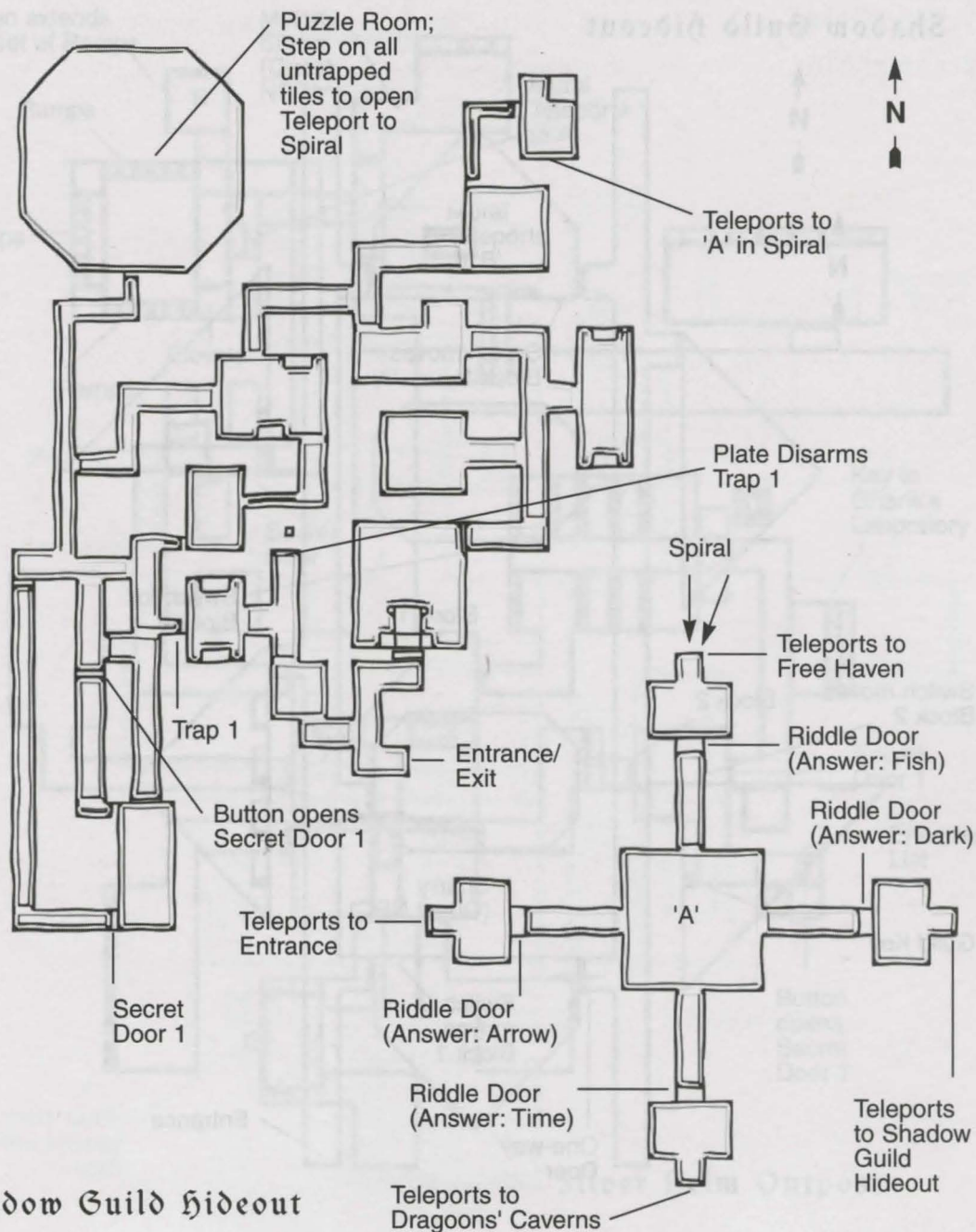

Shadow Guild Hideout

Shadow Guild Hideout

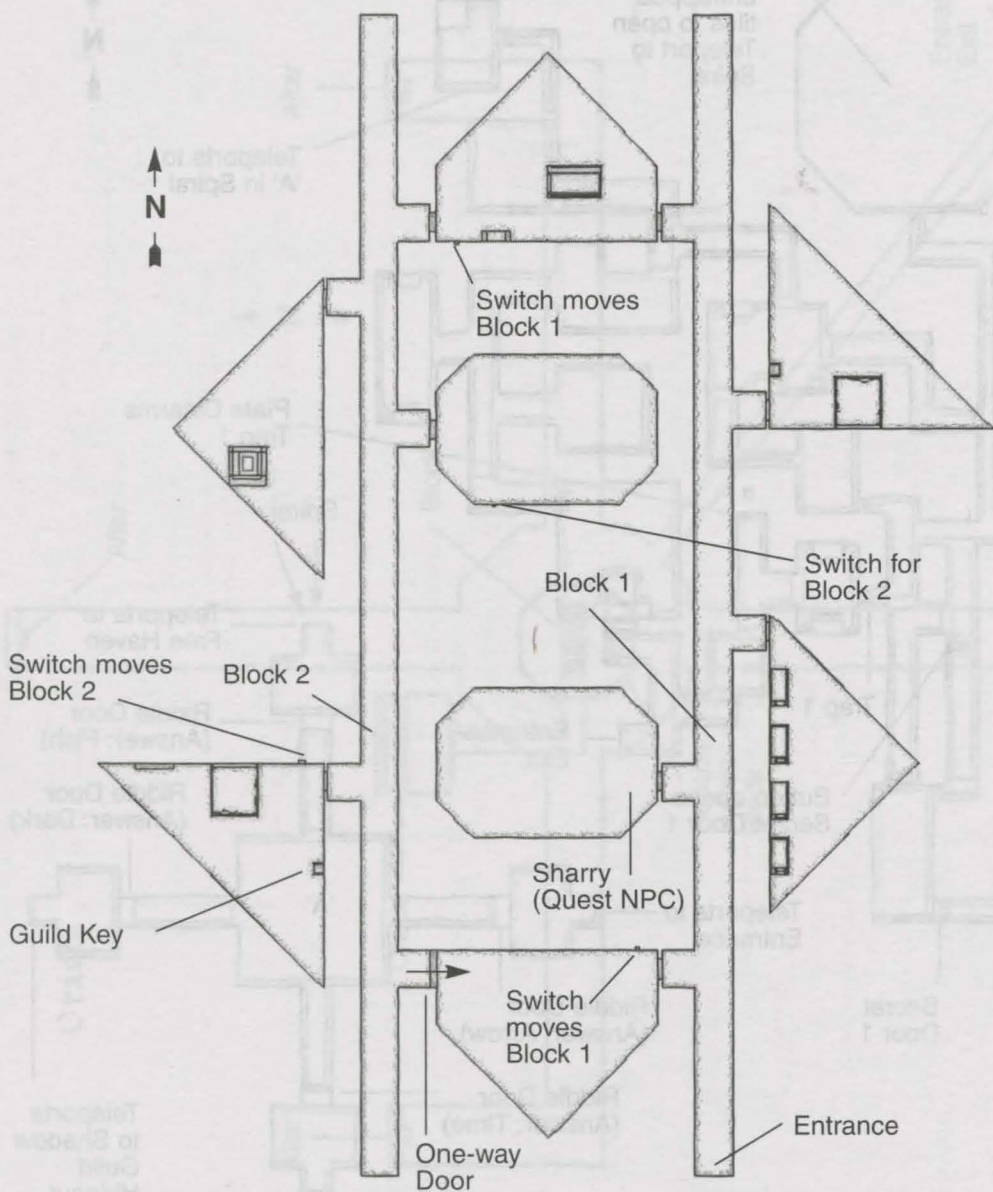

APPENDIX The Cartographer's Pantry: Maps

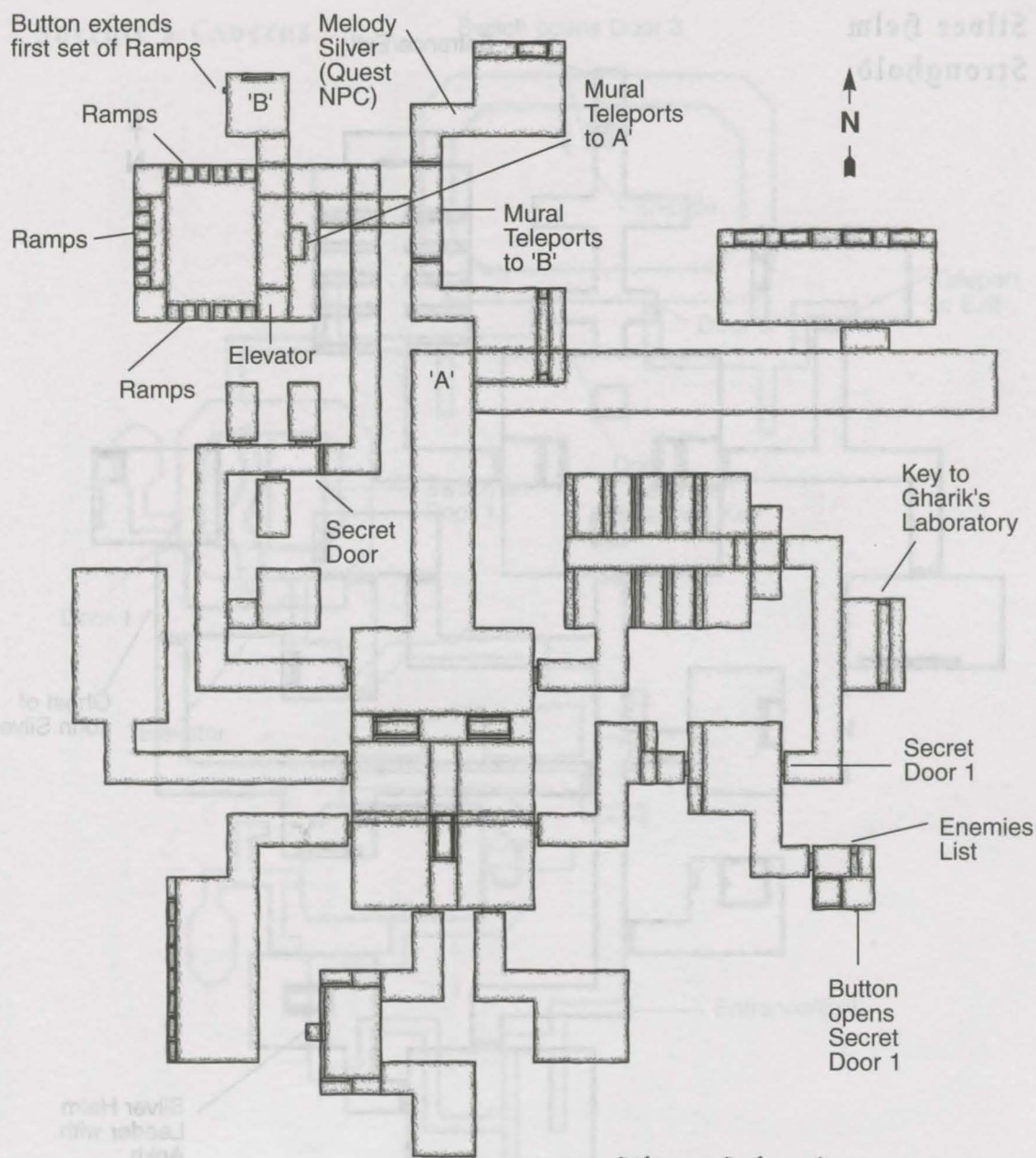

Silver Helm Stronghold

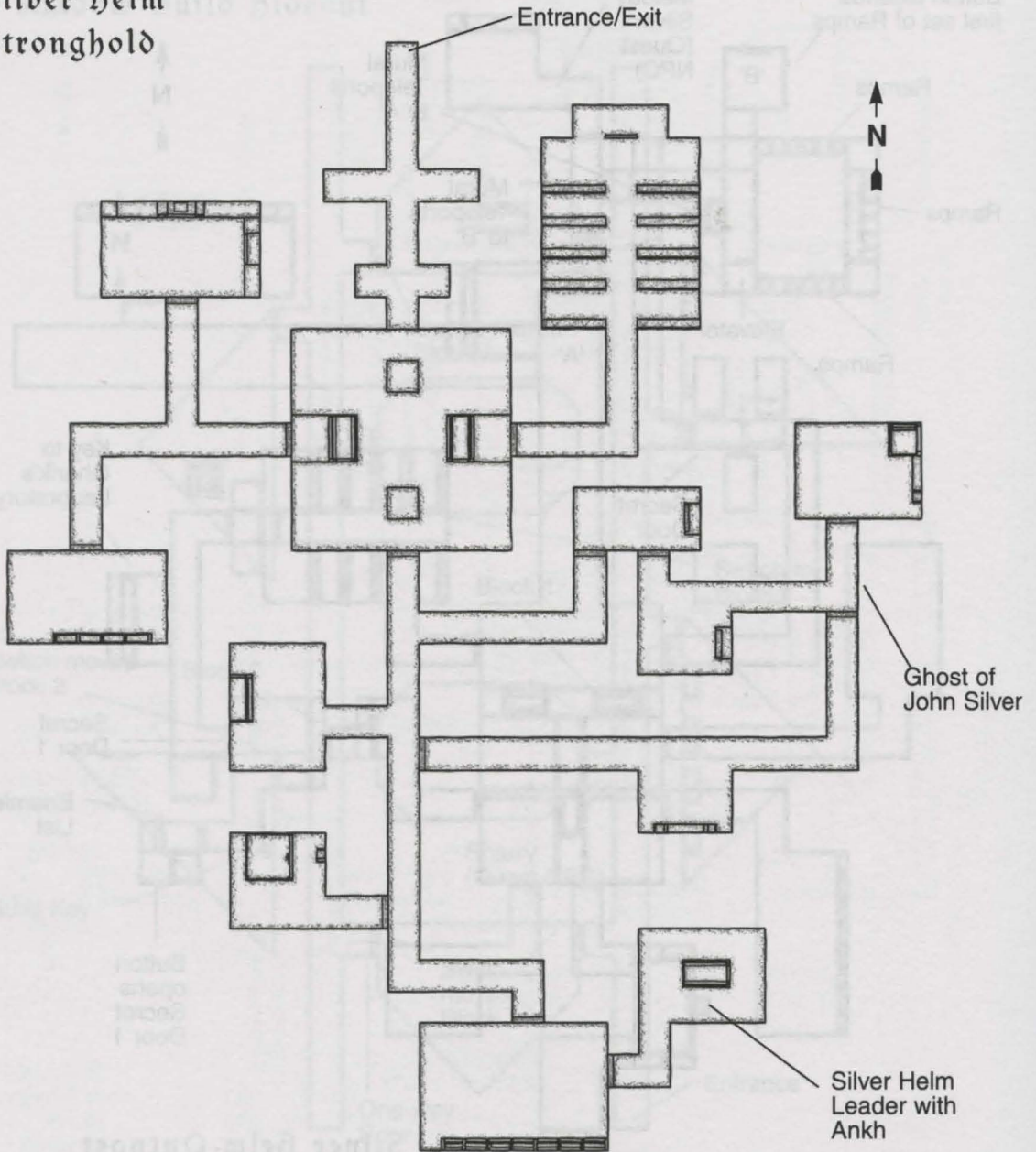

APPENDIX The Cartographer's Pantry:
Maps

Snergle's Caverns

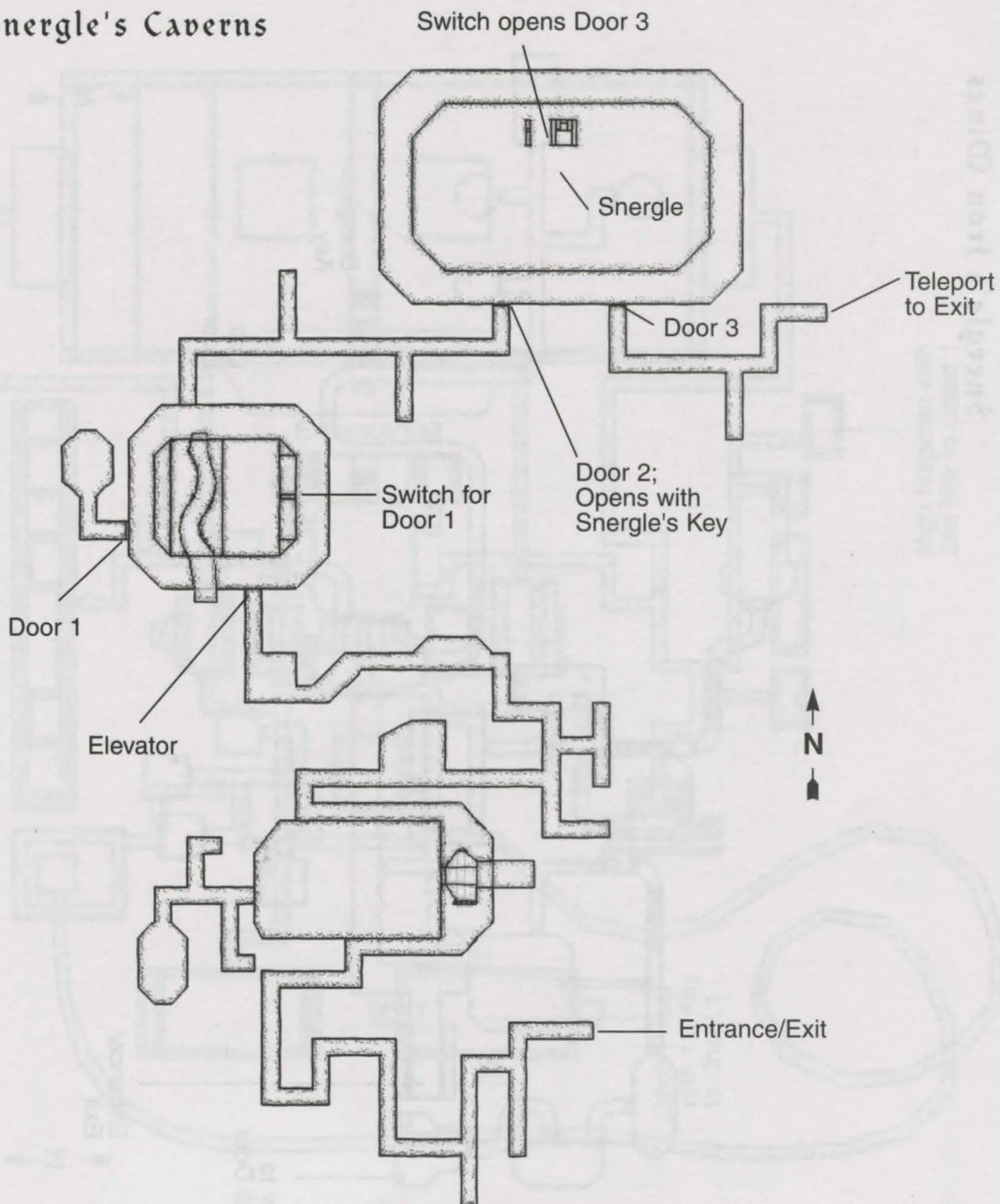

Snergle's Iron Mines

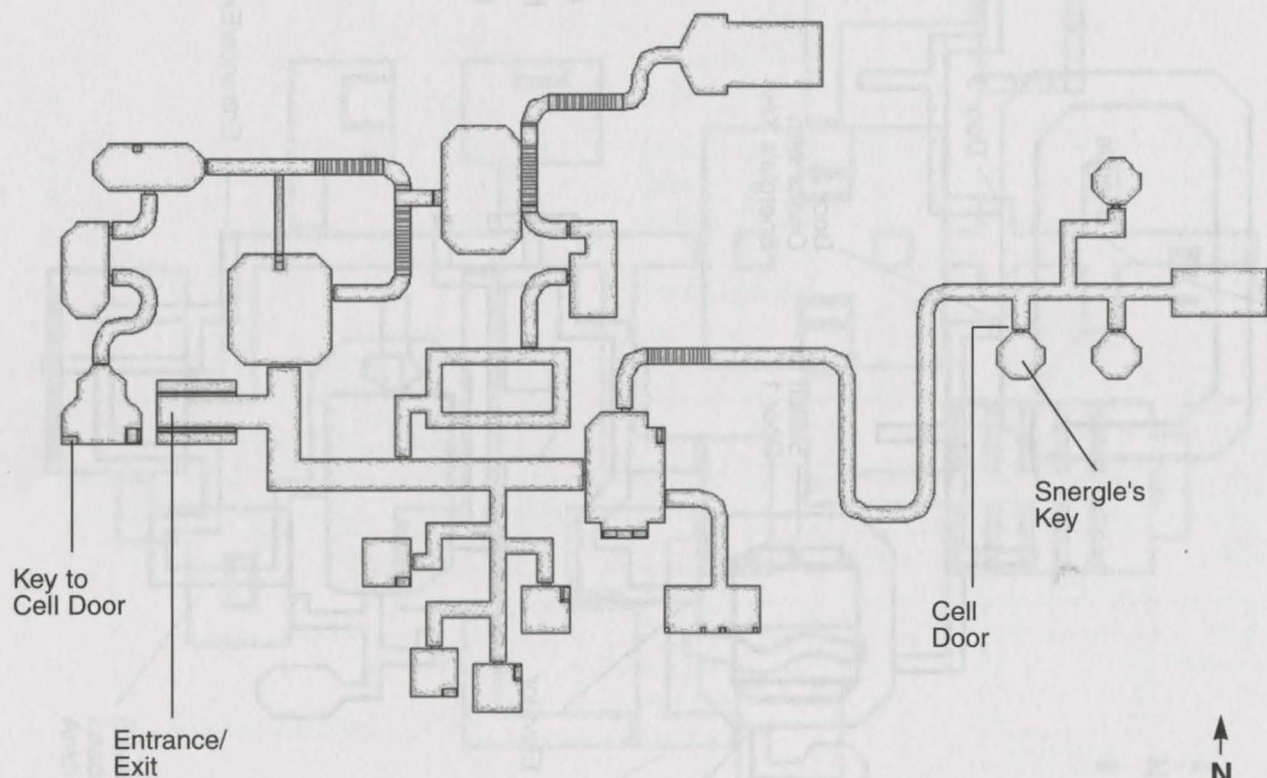

Superior Temple of Baa

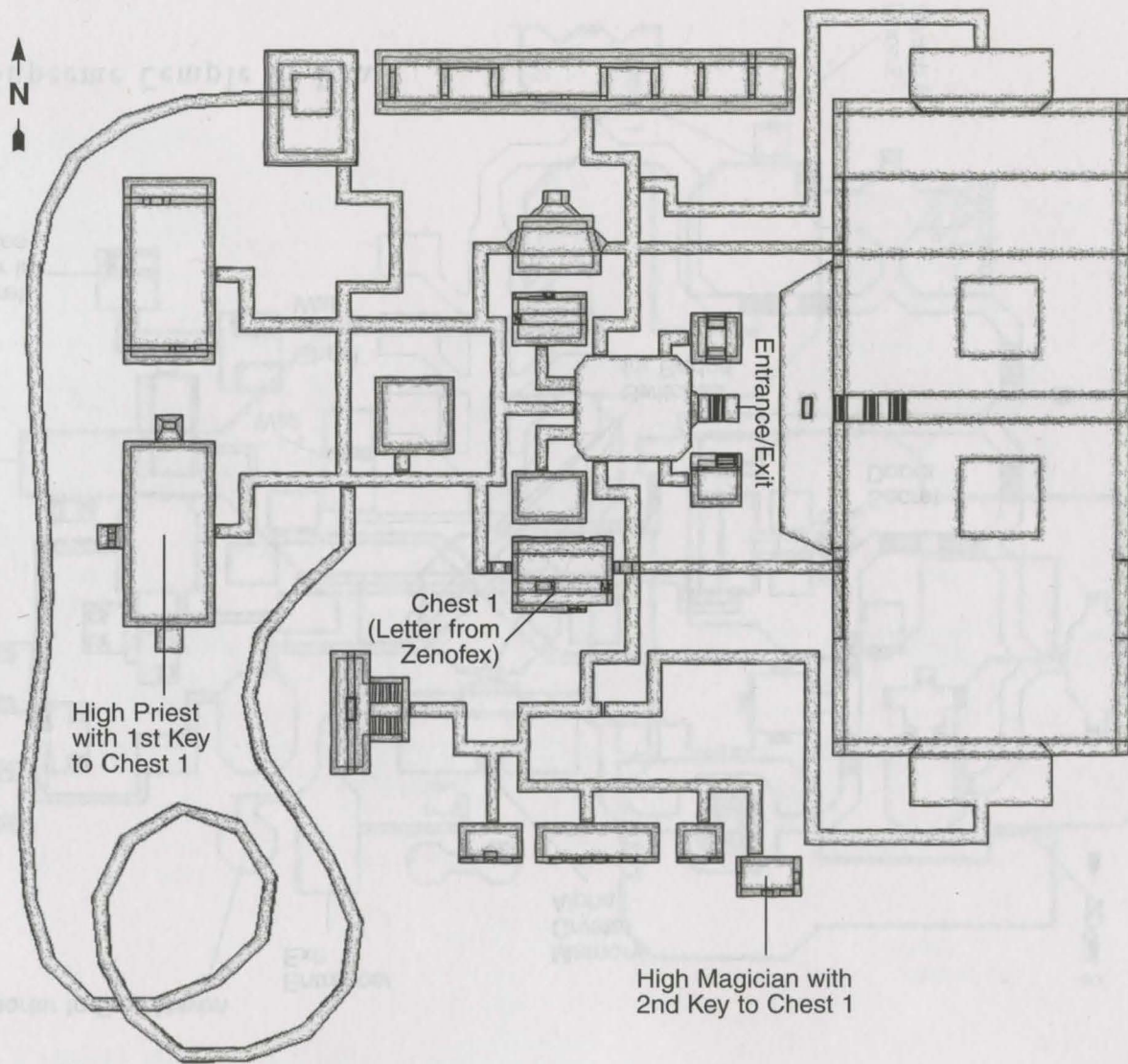

Teleporter to Free Haven

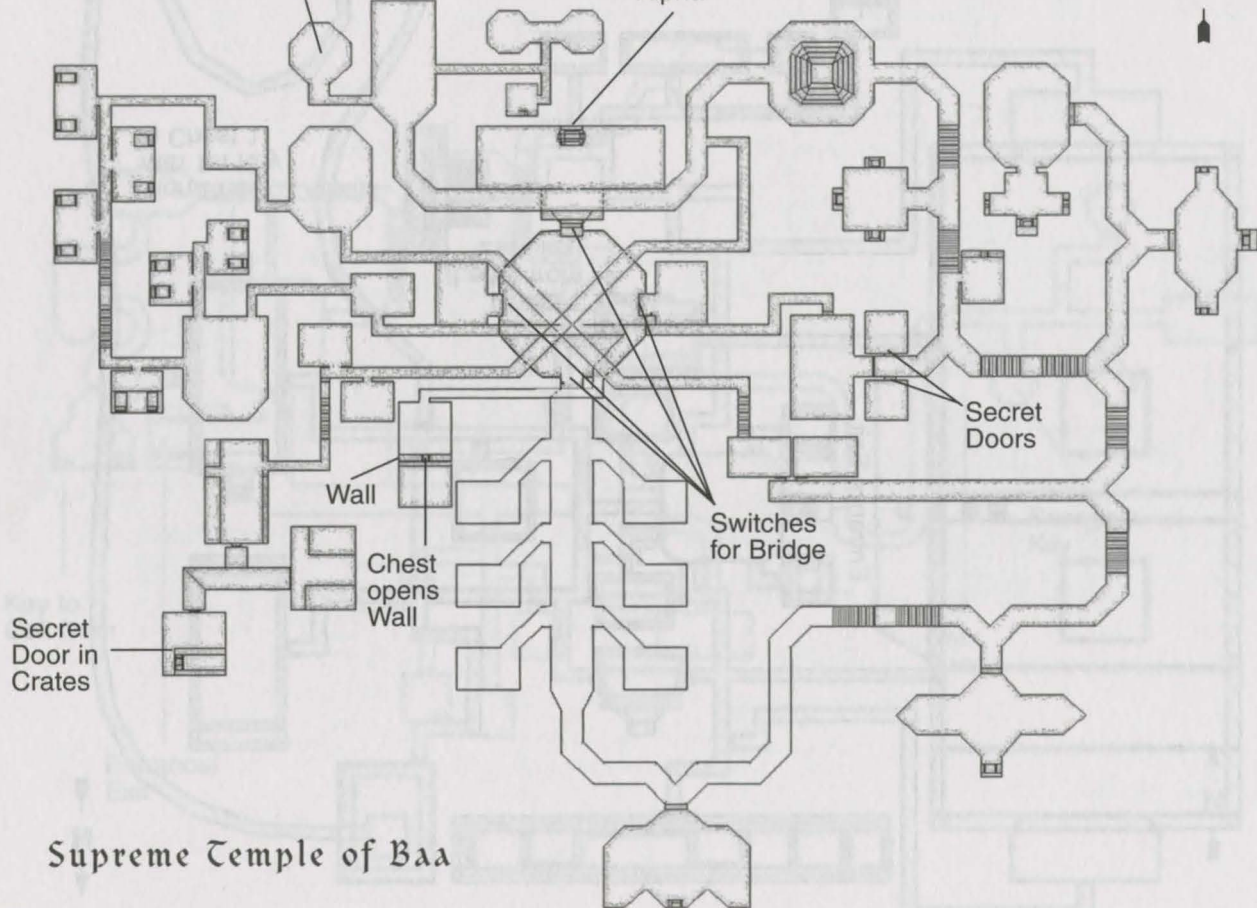
Entrance/
ExitMemory
Crystal
AlphaSecret
Door in
Crates

Wall

Chest opens
WallSecret
DoorsSwitches
for Bridge

Supreme Temple of Baa

APPENDIX The Cartographer's Pantry:
Maps

Temple of the Fist

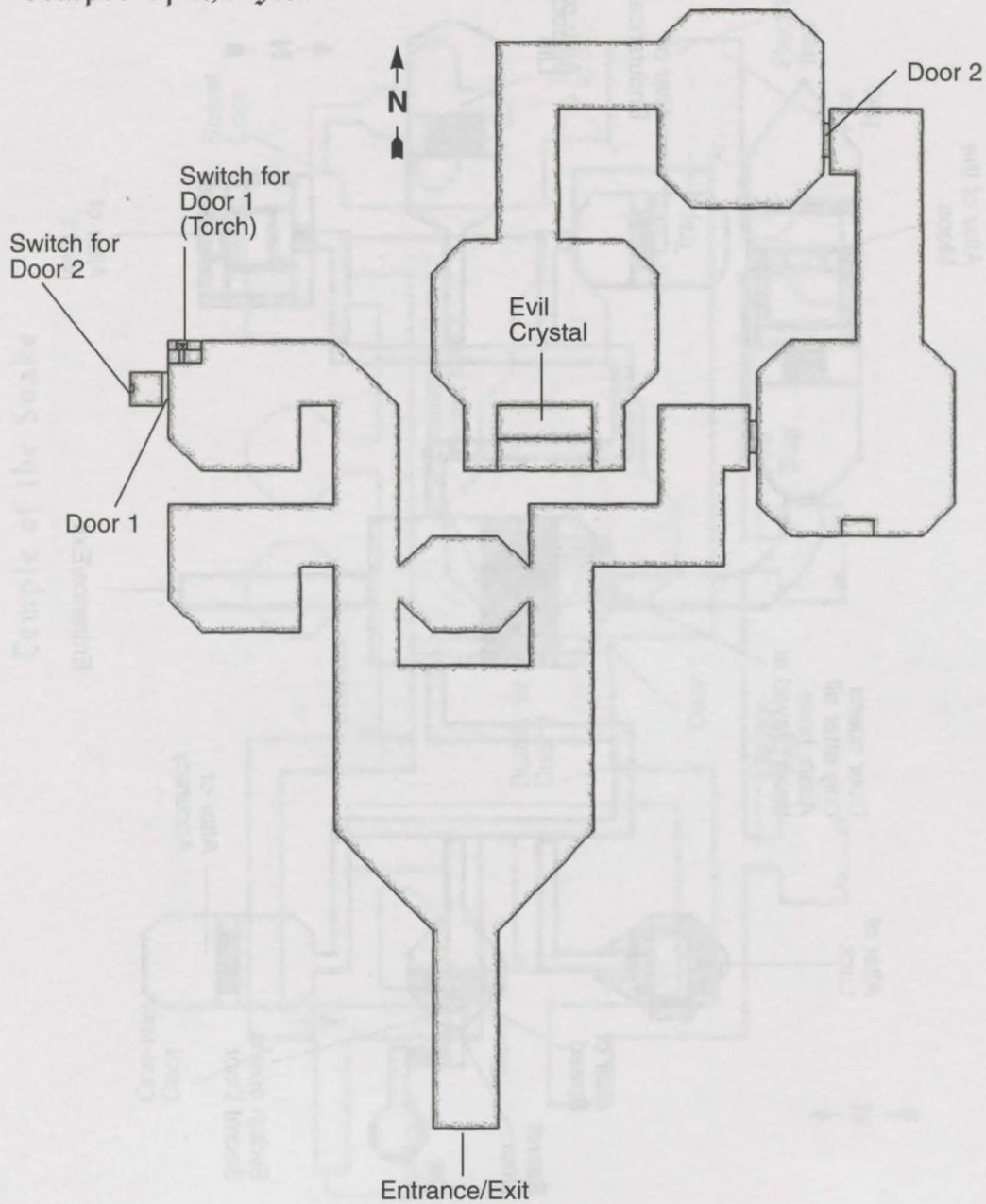

Temple of the Moon

Subsector to First Haven

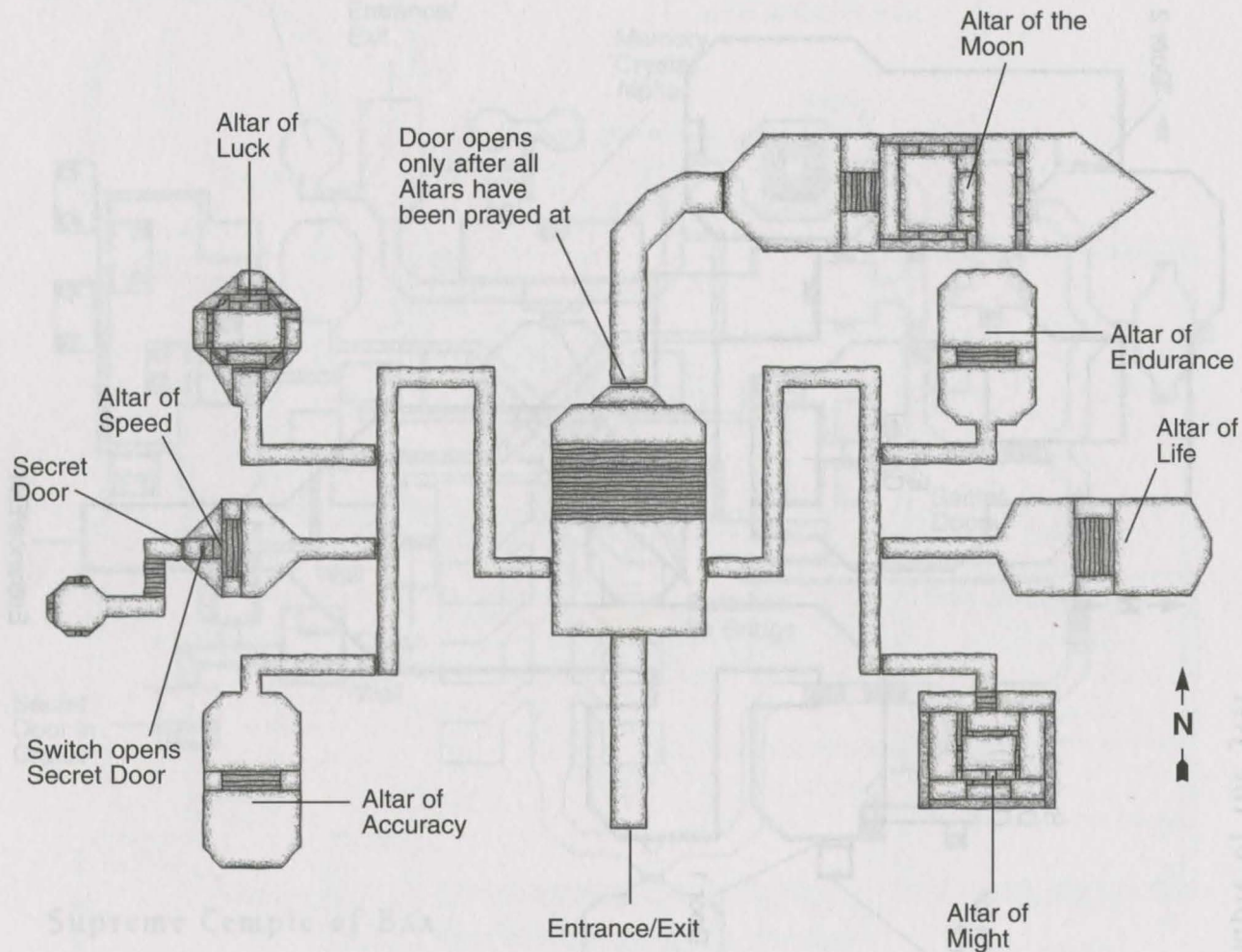

Temple of the Snake

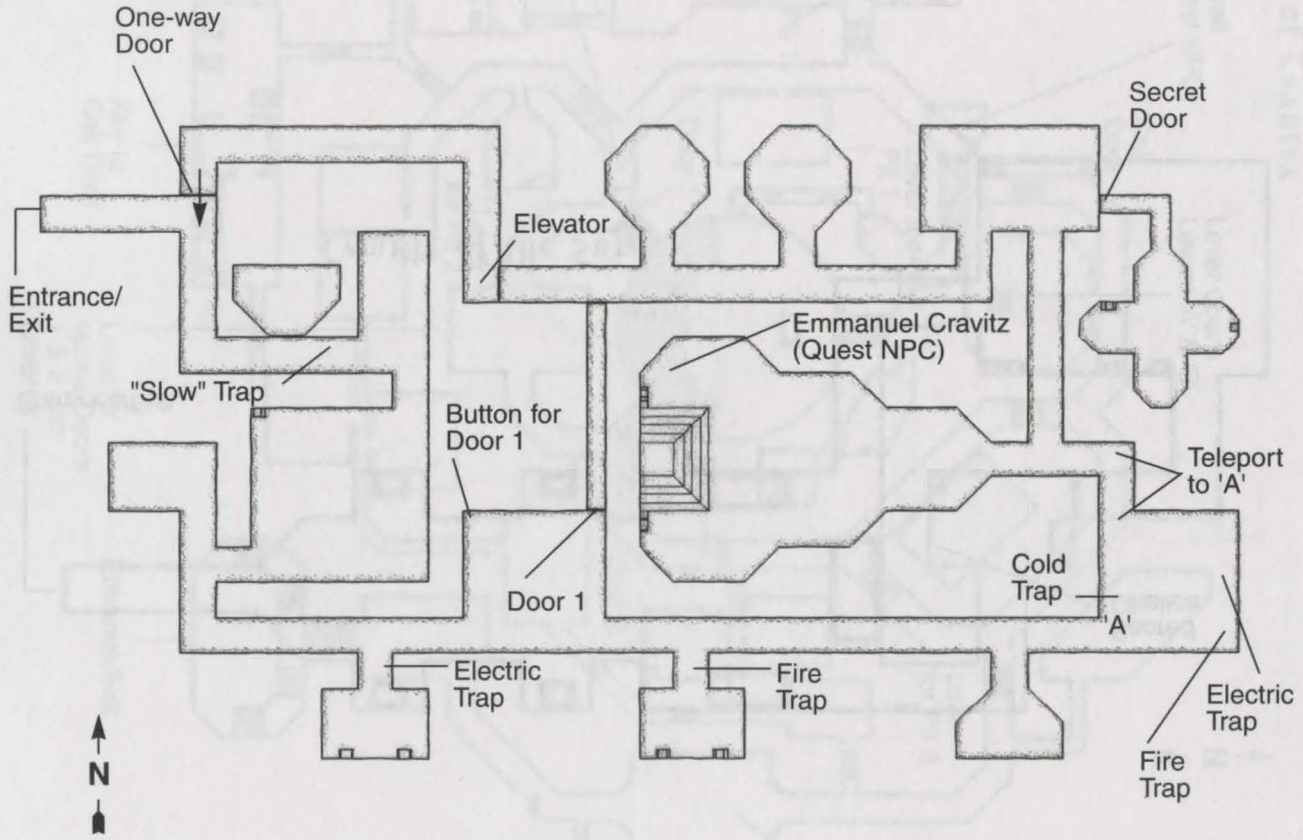

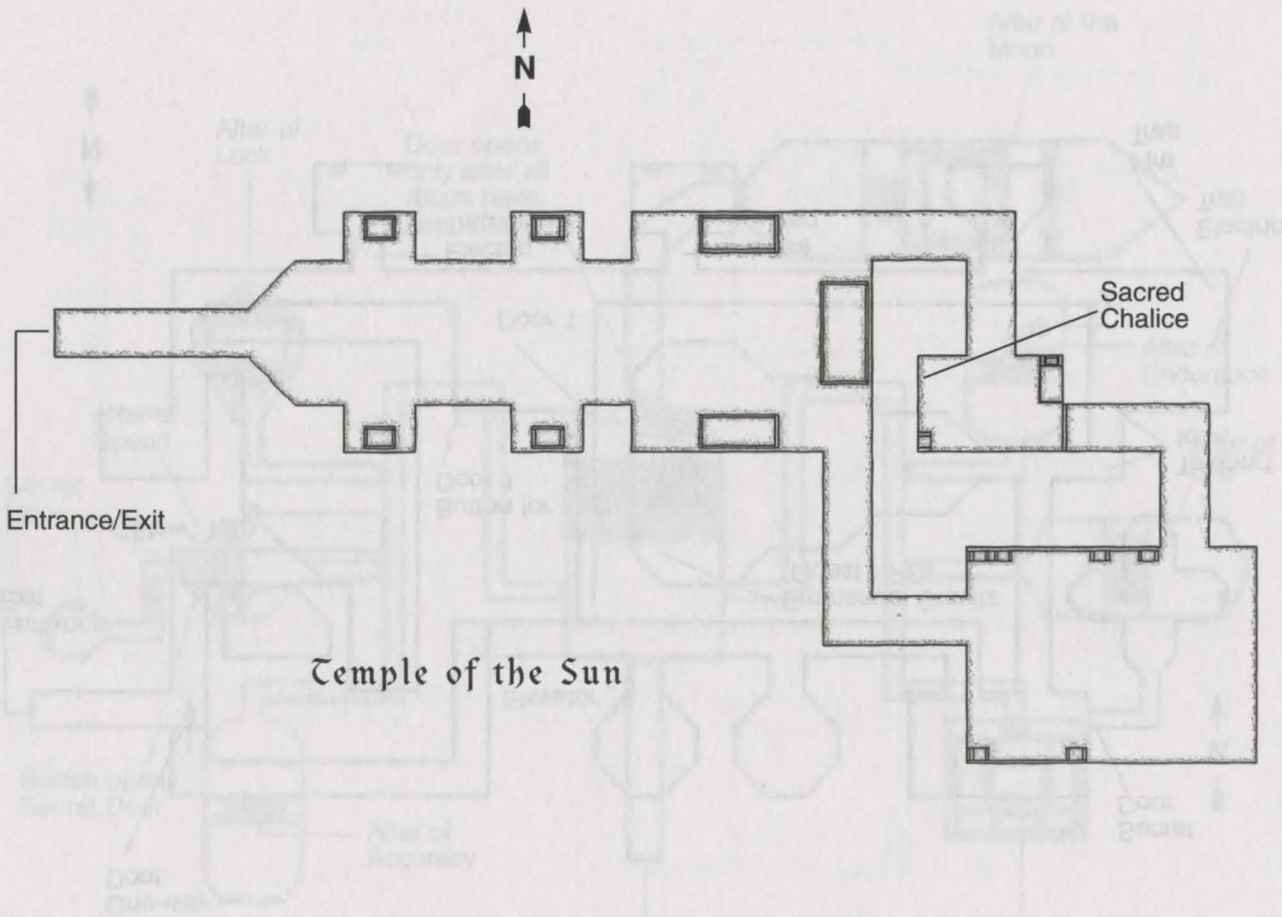

Temple of the Sun

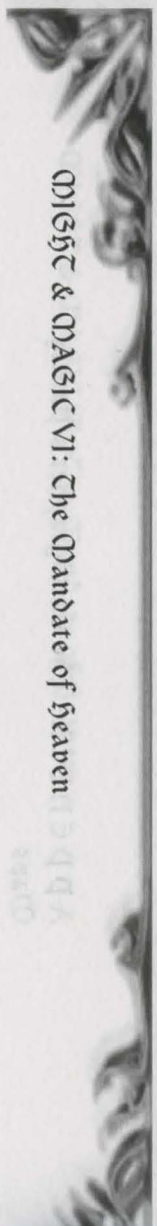

APPENDIX The Cartographer's Pantry:
Maps

Temple of Tsantsa

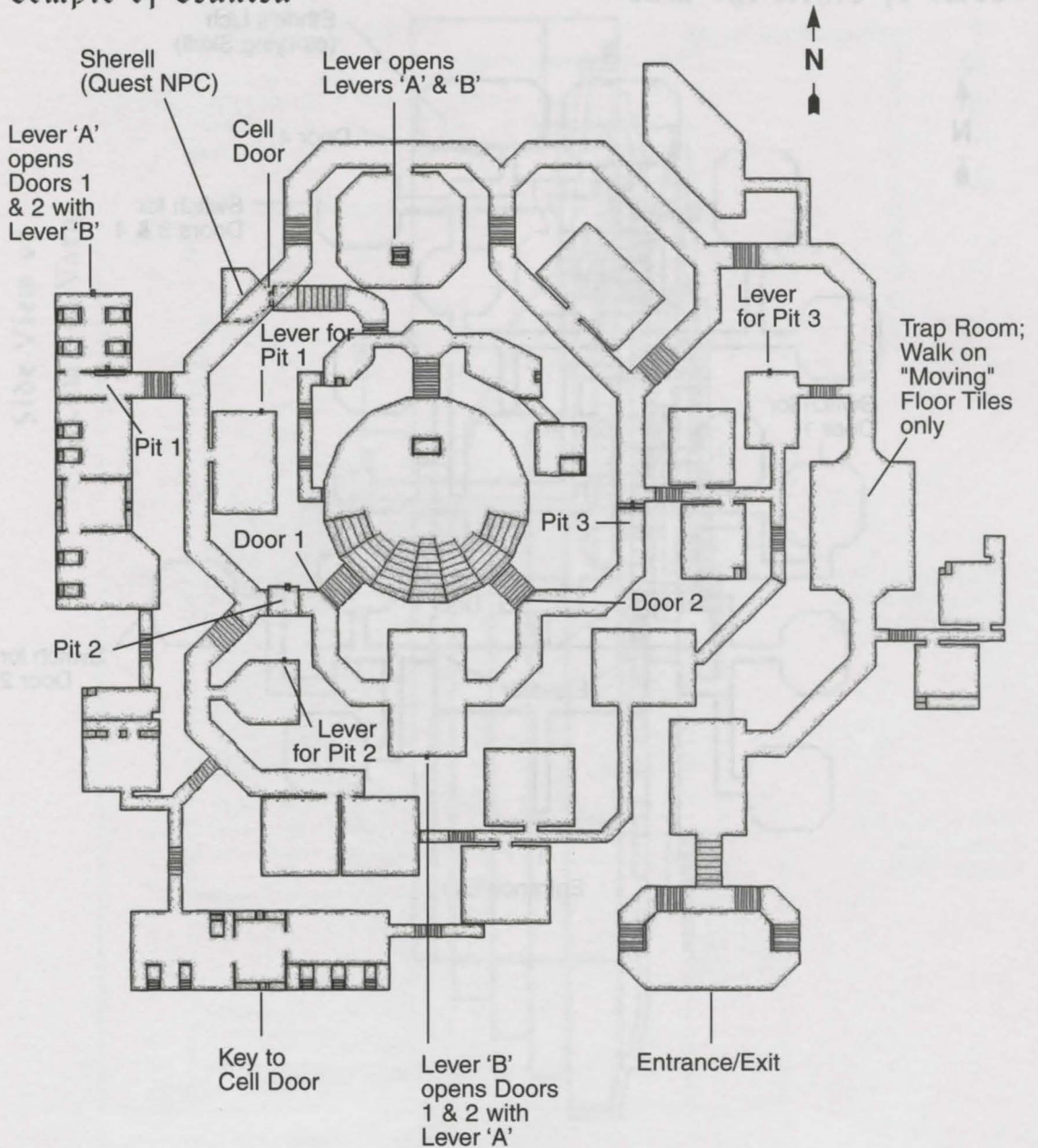

Tomb of Ethric the Mad

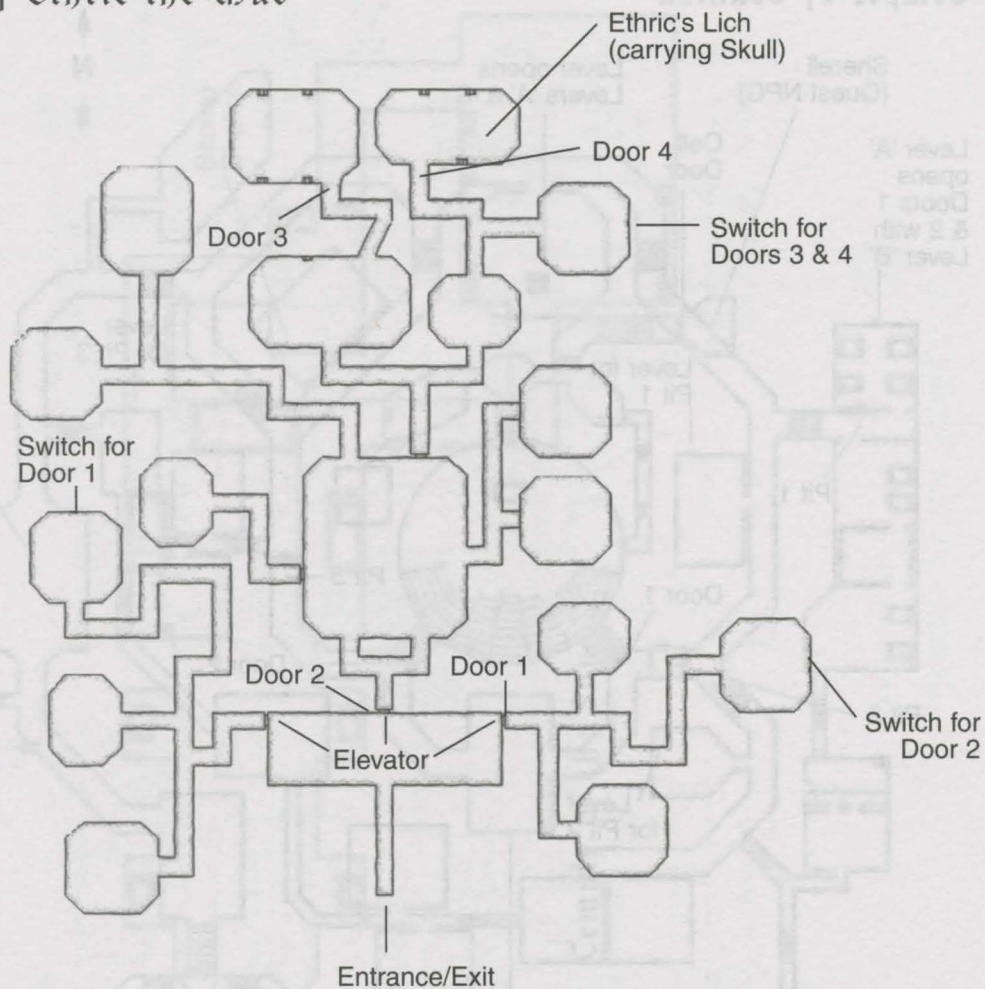
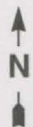

Side View of
Tomb of Varn

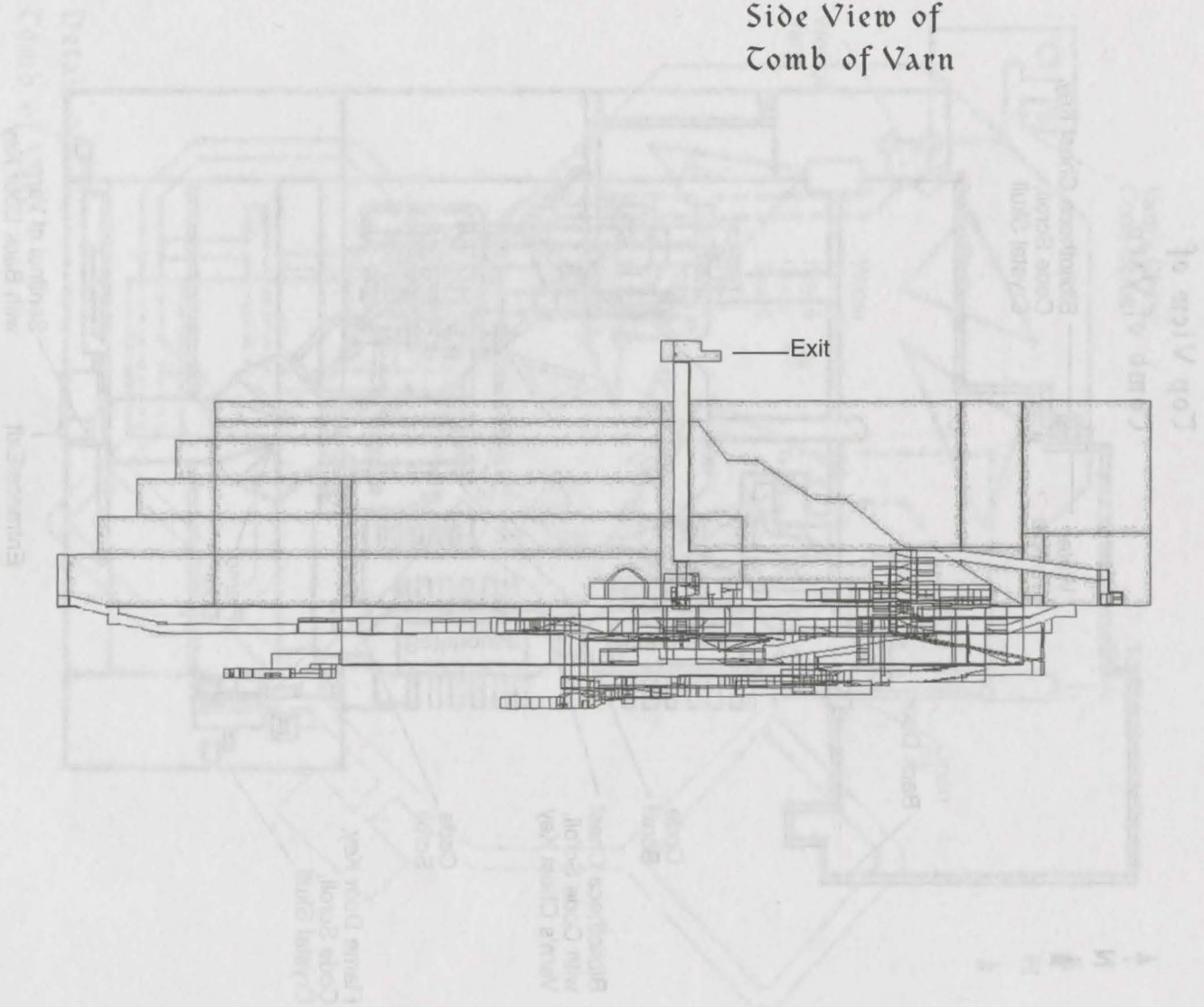

Top View of
Tomb of Varn

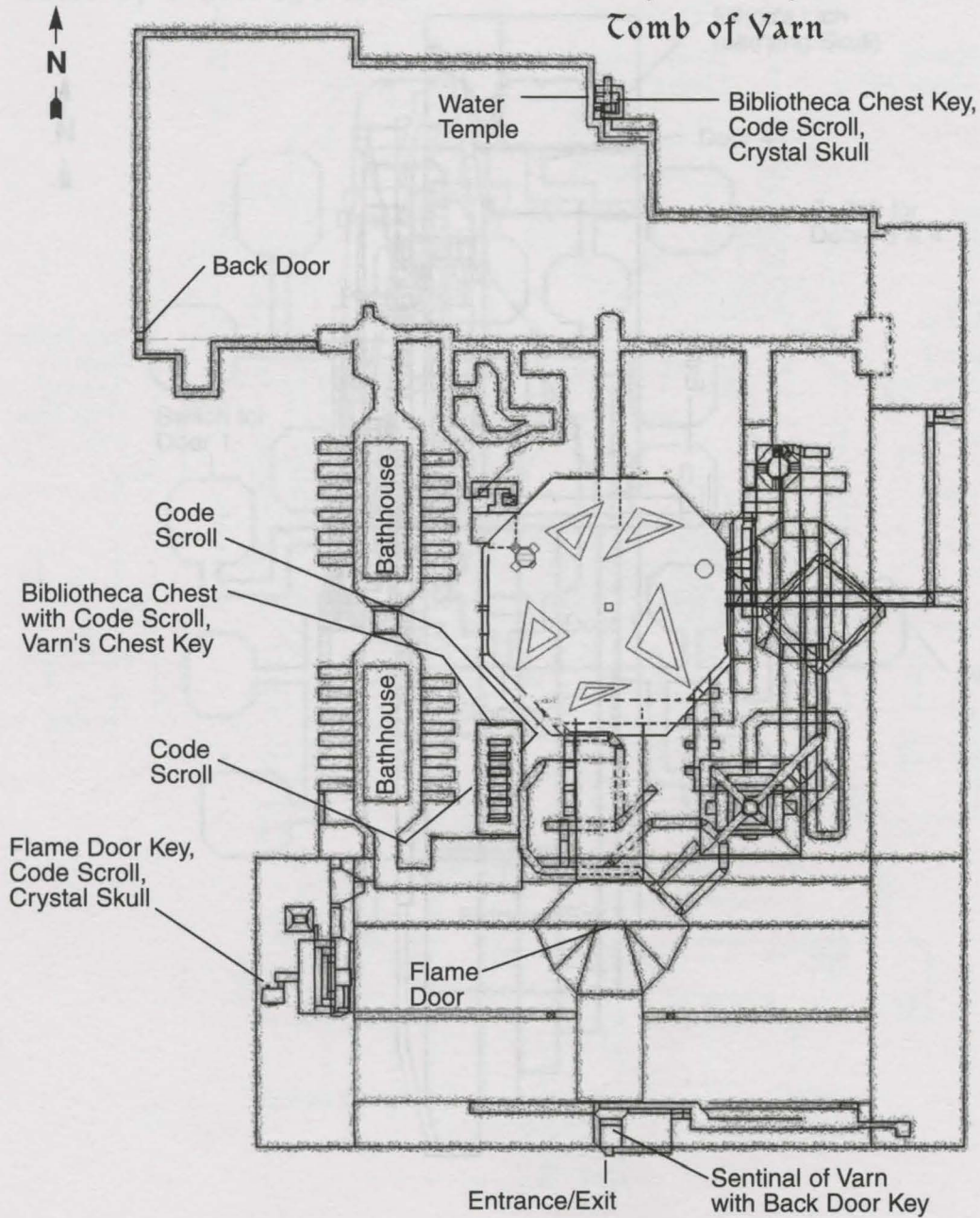

APPENDIX The Cartographer's Pantry:
Maps

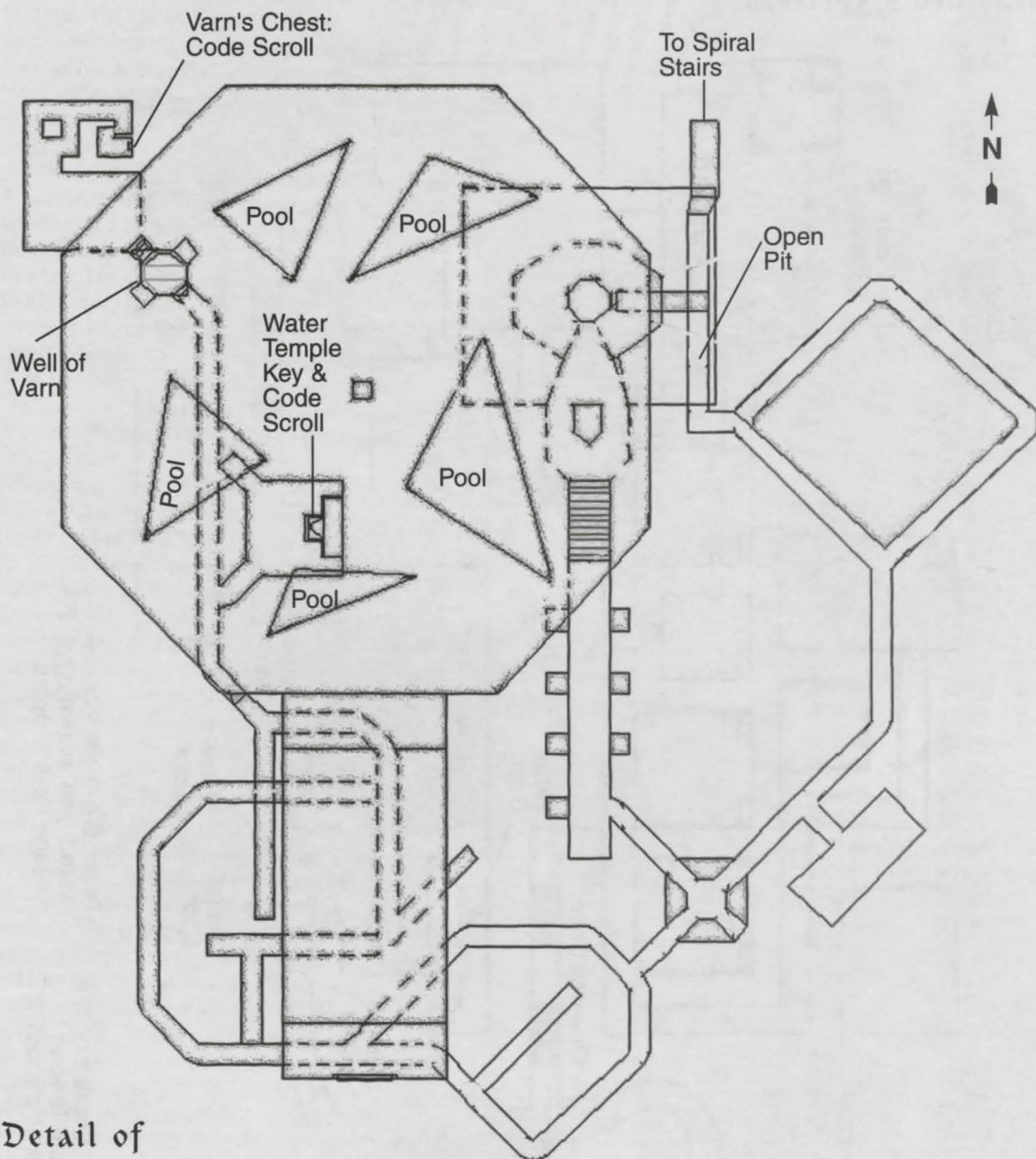

Detail of
Tomb of Varn

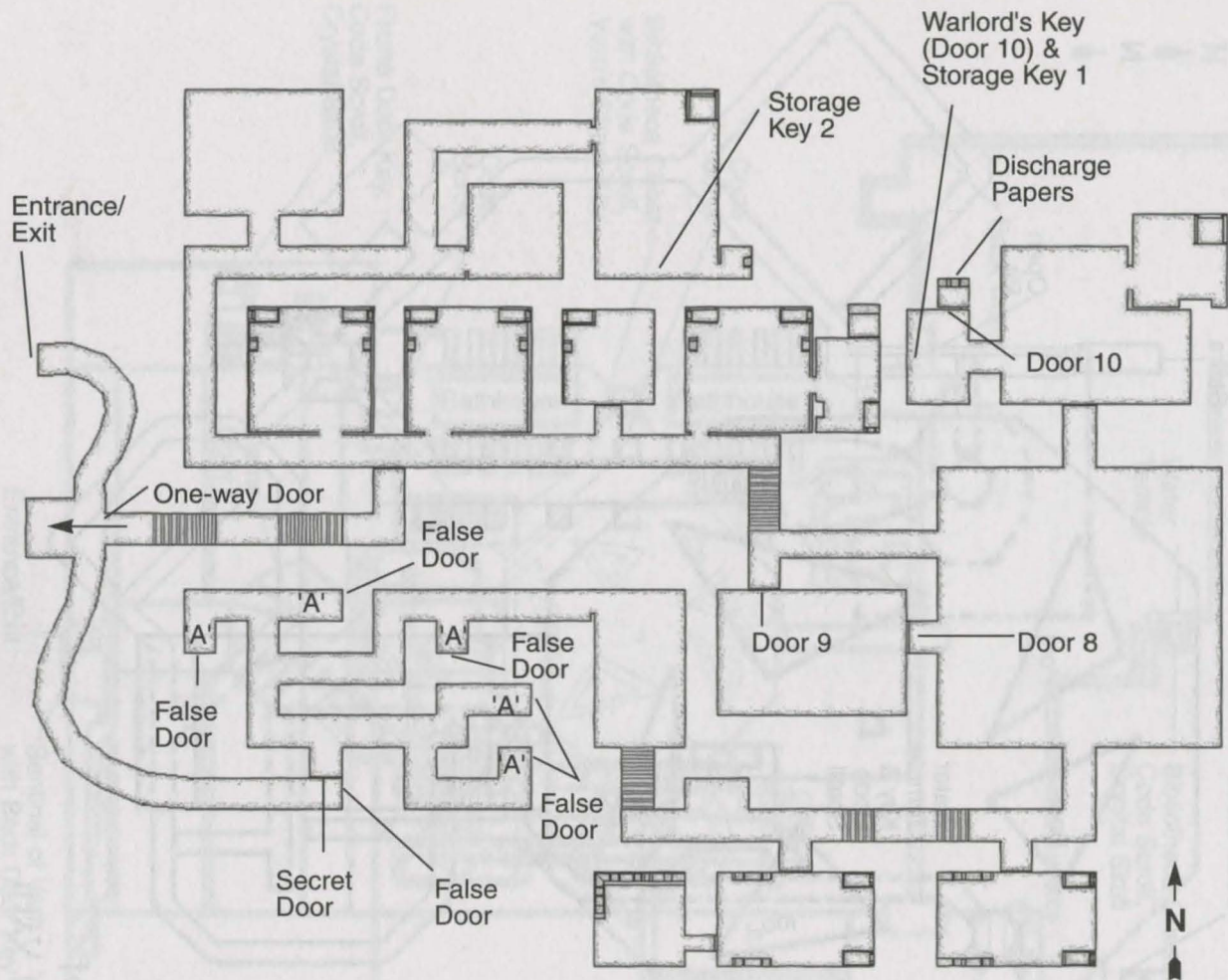

False Doors trigger a random Teleport to locations marked 'A'

Doors 8 & 9 are "double-locked" and require both Storage Keys to open.

Warlord's Fortress

SPECIAL SAVINGS FROM PRIMA!

Computer Game Books

	Original Price	New Savings Price
1942: The Pacific Air War—The Official Strategy Guide	\$19.95	\$9.99
A-Train: The Official Strategy Guide	\$19.95	\$9.99
Aces Over Europe: The Official Strategy Guide	\$19.95	\$9.99
Across The Rhine: The Official Strategy Guide	\$19.95	\$9.99
Aegis—Guardian of the Fleet: The Official Strategy Guide	\$19.95	\$9.99
Alone in the Dark 3: The Official Strategy Guide	\$19.95	\$9.99
Angel Devoid: The Official Strategy Guide	\$19.95	\$9.99
Armored Fist: The Official Strategy Guide	\$19.95	\$9.99
Ascendancy: The Official Strategy Guide	\$19.95	\$9.99
Cyberia: The Official Strategy Guide	\$19.95	\$9.99
Dark Seed II: The Official Strategy Guide	\$19.95	\$9.99
Descent: The Official Strategy Guide	\$19.95	\$9.99
DOOM Battlebook	\$19.95	\$9.99
Dungeon Master II: The Legend of Skullkeep—The Official Strategy Guide	\$19.95	\$9.99
Empire Deluxe: The Official Strategy Guide	\$19.95	\$9.99
Fleet Defender: The Official Strategy Guide	\$19.95	\$9.99
Frankenstein: Through the Eyes of the Monster—The Official Strategy Guide	\$19.95	\$9.99
Hell: A Cyberpunk Thriller—The Official Strategy Guide	\$19.95	\$9.99
Heretic: The Official Strategy Guide	\$19.95	\$9.99
In The 1st Degree: The Official Strategy Guide	\$19.95	\$9.99
King's Quest VII: The Unauthorized Strategy Guide	\$19.95	\$9.99
The Legend of Kyrandia: The Official Strategy Guide	\$19.95	\$9.99
Marathon: The Official Strategy Guide	\$19.95	\$9.99
Master of Orion: The Official Strategy Guide	\$19.95	\$9.99
Master of Magic: The Official Strategy Guide	\$19.95	\$9.99
Microsoft Arcade: The Official Strategy Guide	\$19.95	\$9.99
Microsoft Golf 2: The Official Strategy Guide	\$19.95	\$9.99
Might and Magic Compendium: The Authorized Strategy Guide for I, II, III & IV	\$19.95	\$9.99
Mission Critical: The Official Strategy Guide	\$19.95	\$9.99
Oregon Trail II: The Official Strategy Guide	\$19.95	\$9.99
Outpost: The Official Strategy Guide	\$19.95	\$9.99
Pagan Ultima 8: The Official Strategy Guide	\$19.95	\$9.99
Perfect General II: The Official Strategy Guide	\$19.95	\$9.99
Prince of Persia: The Official Strategy Guide	\$19.95	\$9.99
Sid Meier's Colonization: Official Strategy Guide	\$19.95	\$9.99
Sim City 2000: Power, Politics, and Planning	\$19.95	\$9.99
SimEarth: The Official Strategy Guide	\$19.95	\$9.99
SimFarm Almanac: The Official Guide to SimFarm	\$19.95	\$9.99
SimLife: The Official Strategy Guide	\$19.95	\$9.99
SimTower: The Official Strategy Guide	\$19.95	\$9.99
SubWar 2050: The Official Strategy Guide	\$19.95	\$9.99
This Means War: The Official Strategy Guide	\$19.95	\$9.99
Thunderscape: The Official Strategy Guide	\$19.95	\$9.99
TIE-Fighter: The Official Strategy Guide	\$19.95	\$9.99
Under a Killing Moon: The Official Strategy Guide	\$19.95	\$9.99
Werewolf vs. Comanche: The Official Strategy Guide	\$19.95	\$9.99
X-COM Terror From The Deep: The Official Strategy Guide	\$19.95	\$9.99
X-COM UFO Defense: The Official Strategy Guide	\$19.95	\$9.99

To Take Advantage of These Great Savings, Call 1-800-531-2343.

Prima

The World Leader in

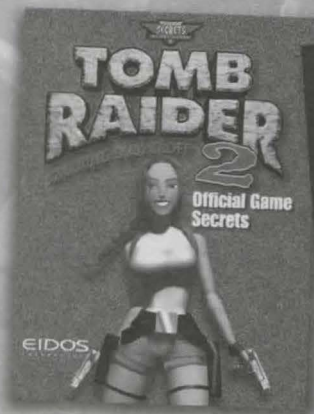

Tomb Raider™ II
The Official Strategy Guide
\$12.99

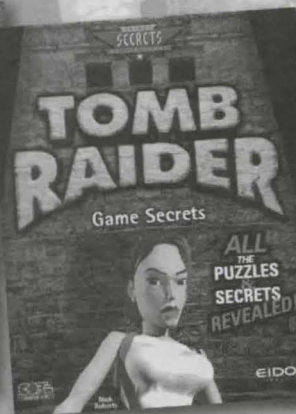

Tomb Raider™
Game Secrets
\$12.99

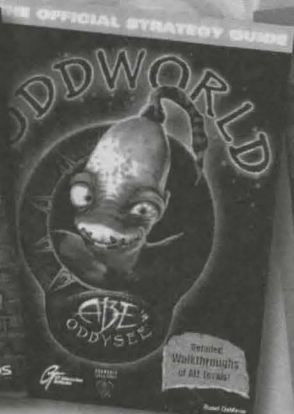

OddWorld™:
Abe's Oddysee
The Official Strategy Guide
\$12.99

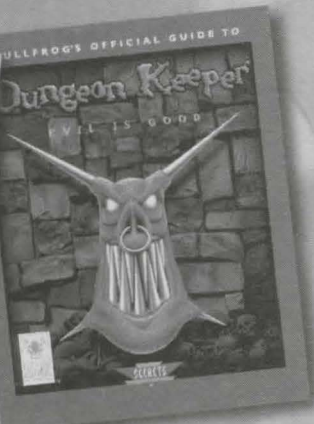

Dungeon Keeper™
Official Secrets
\$19.99

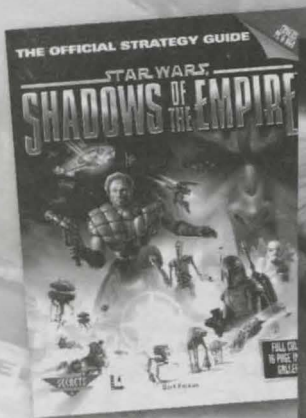

Shadows of the Empire™
Game Secrets
\$12.99

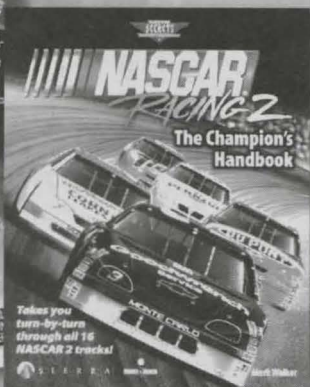

Nascar Racing™ II:
The Champion's Handbook
\$19.99

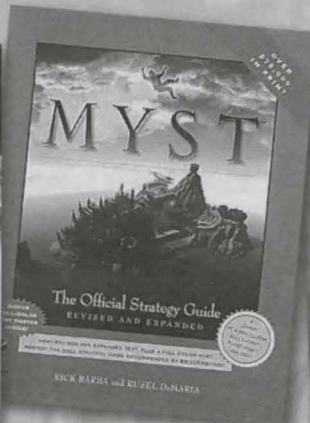

Myst™
The Official Strategy Guide
\$19.95



Dark Earth™
The Official Strategy Guide
\$19.99



Prima Publishing

PO Box 629000 • El Dorado Hills, CA 95762

To Order Call 1-800-531-2343

Secrets of the Games® is a registered trademark of Prima Publishing, a division of Prima Communications, Inc.

Publishing

Electronic Entertainment Books!

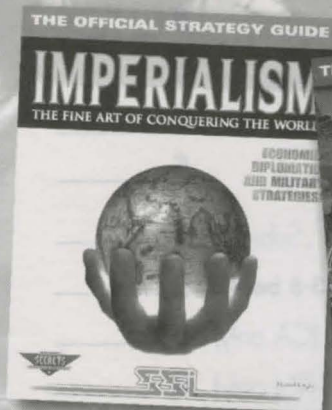

Imperialism™
The Official Strategy Guide
\$19.99



**X-COM
Apocalypse™**
The Official Strategy Guide
\$19.99



**Betrayal in
Antara™**
The Official Strategy Guide,
\$19.99



WarCraft II™:
Dark Saga
Official Game Secrets
\$12.99

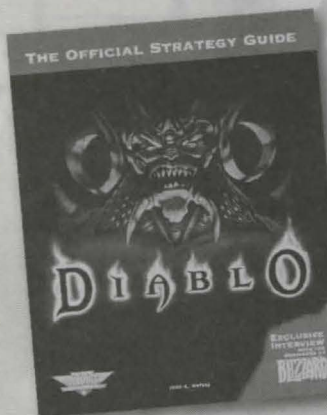

Diablo™
The Official Strategy Guide
\$19.99

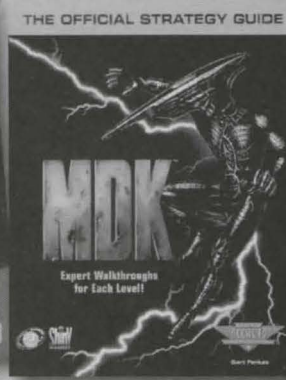

MDK™
The Official Strategy Guide
\$12.99

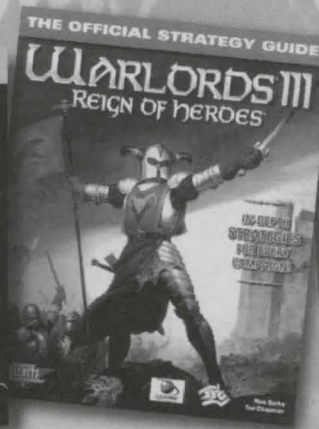

Warlords™ III:
Reign of Heroes
The Official Strategy Guide
\$19.99

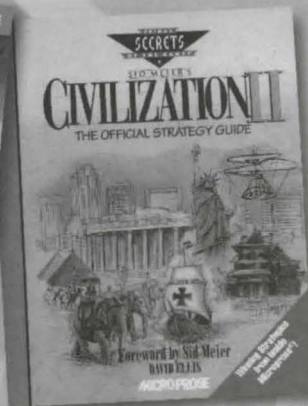

**Sid Meier's
Civilization II™**
The Official Strategy Guide
\$19.99



Include your VISA or Mastercard number, expiration date, and your name and address. Please add \$4.00 shipping and handling for the first book, (\$1.00 for each additional book) in the U.S. (California residents add 7.25% sales tax, Tennessee residents add 8.25% sales tax, Maryland residents add 5% sales tax, Indiana residents add 5% sales tax). Allow 2-3 weeks for delivery. Canadian orders please add \$6.00 shipping and handling (\$1.00 for each additional book) and 7% GST. U.S. funds only, please.

Prima's Secrets of the Games® series is distributed in the UK and EEC by BOXTREE LTD. Look for Prima books at your local bookshop, or order directly through Littlehampton Book Services: Tel. 44 (0) 1903 732596 Fax 44 (0) 1903 730914 Access, Visa and Mastercard accepted.

To Order Books

Please send me the following items:

Quantity	Title	Unit Price	Total
_____	_____	\$ _____	\$ _____
_____	_____	\$ _____	\$ _____
_____	_____	\$ _____	\$ _____
_____	_____	\$ _____	\$ _____
_____	_____	\$ _____	\$ _____

Subtotal \$ _____

Deduct 10% when ordering 3-5 books \$ _____

7.25% Sales Tax (CA only) \$ _____

8.25% Sales Tax (TN only) \$ _____

5.0% Sales Tax (MD and IN only) \$ _____

7.0% G.S.T. Tax (Canada only) \$ _____

Shipping and Handling* \$ _____

Total Order \$ _____

*Shipping and Handling depend on Subtotal.

Subtotal	Shipping/Handling
\$0.00-\$14.99	\$3.00
\$15.00-\$29.99	\$4.00
\$30.00-\$49.99	\$6.00
\$50.00-\$99.99	\$10.00
\$100.00-\$199.99	\$13.50
\$200.00+	Call for Quote

Foreign and all Priority Request orders:
Call Order Entry department
for price quote at 916-632-4400

This chart represents the total retail price of books only
(before applicable discounts are taken).

By Telephone: With American Express, MC or Visa,
call 800-632-8676 or 916-632-4400. Mon-Fri, 8:30-4:30.

www.primapublishing.com

By E-mail: sales@primapub.com

By Mail: Just fill out the information below and send with your remittance to:

**Prima Publishing
P.O. Box 1260BK
Rocklin, CA 95677**

My name is _____

I live at _____

City _____ State _____ ZIP _____

MC/Visa# _____ Exp. _____

Check/money order enclosed for \$ _____ Payable to Prima Publishing

Daytime telephone _____

Signature _____

Defeat the Demons

AND RESTORE THE MANDATE OF HEAVEN

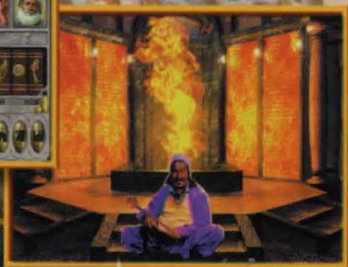

**COMPLETE
WALKTHROUGHS
OF ALL MAJOR
QUESTS**



**COMPLETE
CHARACTER
STATS**



**UNBEATABLE
STRATEGIES FOR
ALL SCENARIOS**



**EXTENSIVE
MONSTER
TABLES**



**EXHAUSTIVE
SPELL AND
SKILL LISTS**



**DETAILED
MAPS**

Might and Magic, New World Computing, and their respective logos are Registered Trademarks of The 3DO Company.

ISBN 0-7615-1109-1



9 780761 511090 5 1999



0 86874 51109 5



The Prima Logo and Prima Publishing® are Registered Trademarks of Prima Communications, Inc.

www.primagames.com

Platform: PC