

# THE OFFICIAL STRATEGY GUIDE

TM



THIS IS THE ONLY  
OFFICIAL STRATEGY GUIDE  
AVAILABLE AND CONTAINS  
SECRETS YOU CANNOT FIND  
ANYWHERE ELSE!

 GT Interactive Software

ED DILLE

 id  
SOFTWARE

3

ISBN 1-55958-711-3



0 86874 00711 6

# DOOM II

THE OFFICIAL STRATEGY  
GUIDE

## Now Available

### Computer Game Books

SimEarth: The Official Strategy Guide  
Wing Commander I and II: The Ultimate Strategy Guide  
Chuck Yeager's Air Combat Handbook  
Ultima: The Avatar Adventures  
A-Train: The Official Strategy Guide  
Global Conquest: The Official Strategy Guide (with disk)  
Falcon 3: The Official Combat Strategy Book (with disk)  
Gunship 2000: The Official Strategy Guide  
Dynamix Great War Planes: The Ultimate Strategy Guide  
SimLife: The Official Strategy Guide  
Populous: The Official Strategy Guide  
Stunt Island: The Official Strategy Guide  
Ultima VII and Underworld: More Avatar Adventures  
X-Wing: The Official Strategy Guide  
Prince of Persia: The Official Strategy Guide  
Empire Deluxe: The Official Strategy Guide  
F-15 Strike Eagle III: The Official Strategy Guide (with disk)  
Lemmings: The Official Companion (with disk)  
Secret of Mana Official Game Secrets  
The 7th Guest: The Official Strategy Guide  
Myst: The Official Strategy Guide  
Return to Zork Adventurer's Guide  
Microsoft Flight Simulator: The Official Strategy Guide  
Strike Commander: The Official Strategy Guide  
Might and Magic Compendium:  
The Authorized Strategy Guide for Games I, II, III, and IV  
SimFarm Almanac: The Official Guide to SimFarm  
SimCity 2000: Power, Politics, and Plan  
Master of Orion: The Official Strategy Guide  
Outpost: The Official Strategy Guide  
SSN-21 Seawolf: The Official Strategy Guide  
Alone in the Dark: The Official Strategy Guide  
Betrayal at Krondor: the Official Strategy Guide

#### How to Order:

Individual orders and quantity discounts are available from the publisher, Prima Publishing, P.O. Box 1260BK, Rocklin, CA 95677-1260; (916) 632-4400. For quantity orders, include information on your letterhead concerning the intended use of the books and the number of books you wish to purchase. For individual orders, turn to the back of the book for more information.

# **DOOM II**

## **THE OFFICIAL STRATEGY GUIDE**

**ED DILLE**



Prima Publishing  
P.O. Box 1260BK  
Rocklin, CA 95677-1260

Copyright © 1994 by id Software. All rights reserved. No part of this book may be reproduced or transmitted in any form or by any means, electronic or mechanical, including photocopying, recording, or by any information storage or retrieval system without written permission from Prima Publishing, except for the inclusion of quotations in a review.

Executive Editor: Roger Stewart  
Managing Editor: Neweleen A. Trebnik  
Creative Director, *Secrets of the Games*: Rusel DeMaria  
Project Editor: Becky Freeman  
Cover Production Coordinator: Anne Johnson  
Copyeditor: Judith Brown  
Book Design and Layout: Marian Hartsough Associates  
Adaptation to Cover: Dunlavey Studio  
Illustrations: Edwin Smith and Ocean Quigley

*DOOM II* and the *DOOM II* logo are a copyright of id Software, Inc.

All products and characters mentioned in this book are trademarks of their respective companies.

**Important:**

Prima Publishing, Inc., has made every effort to determine that the information contained in this book is accurate. However, the publisher makes no warranty, either express or implied, as to the accuracy, effectiveness, or completeness of the material in this book; nor does the publisher assume liability for damages, either incidental or consequential, that may result from using the information in this book. The publisher cannot provide information regarding game play, hints and strategies, or problems with hardware or software. Questions should be directed to the support numbers provided by the game and device manufacturers in their documentation. Some game tricks require precise timing and may require repeated attempts before the desired result is achieved.

ISBN: 1-55958-711-3

Library of Congress Card Number: 94-068399

Printed in the United States of America

94 95 96 97 CWO 10 9 8 7 6 5 4 3 2

# CONTENTS

Introduction . . . . .	.xi
Chapter One: Staying in Control . . . . .	.1
Chapter Two: Navigation and Object Recognition . . . . .	.9
Chapter Three: Peace through Superior Firepower . . . . .	.23
Chapter Four: The Bestiary . . . . .	.31
Chapter Five: Infantry Basics . . . . .	.41
Chapter Six: Intelligence Briefings . . . . .	.53
Mission 1: Entryway . . . . .	.55
Mission 2: Underhalls . . . . .	.58
Mission 3: The Gantlet . . . . .	.62
Mission 4: The Focus . . . . .	.69
Mission 5: The Waste Tunnels . . . . .	.73
Mission 6: The Crusher . . . . .	.77
Mission 7: Dead Simple . . . . .	.83
Mission 8: Tricks and Traps . . . . .	.86
Mission 9: The Pit . . . . .	.90
Mission 10: Refueling Base . . . . .	.95
Mission 11: 'O' of Destruction! . . . . .	.99
Mission 12: The Factory . . . . .	.102
Mission 13: Downtown . . . . .	.106
Mission 14: The Inmost Dens . . . . .	.110



## **DOOM II Hell on Earth**

Mission 15: Industrial Zone .....	114
Mission 16: Suburbs .....	120
Mission 17: Tenemants .....	124
Mission 18: The Courtyard .....	131
Mission 19: The Citadel .....	134
Mission 20: Gotcha! .....	140
Mission 21: Nirvana .....	145
Mission 22: The Catacombs .....	149
Mission 23: Barrels O' Fun .....	153
Mission 24: The Chasm .....	158
Mission 25: Bloodfalls .....	162
Mission 26: The Abandoned Mines .....	167
Mission 27: Monster Condo .....	171
Mission 28: The Spirit World .....	176
Mission 29: The Living End .....	180
Mission 30: Icon of Sin .....	188
Mission 31: Wolfenstein .....	190
Mission 32: Grosse .....	195
Chapter Seven: Multiplayer Network Notes .....	199
Chapter Eight: Interview .....	205
Appendix: Cheater, Cheater, Demon Eater .....	215



## **Dedication**

To my brother, Brian, who has already been to Hell and back more times than I care to imagine.



# ACKNOWLEDGMENTS

Special thanks to the entire id gang, whose vision has been dark enough to delight thousands of gamers. Also to Allan Blum of GTE Interactive, for taking time out of his hectic schedule to help this project come together. John Withers, Andrew Swann, Marian Hartsough, and Becky Freeman were the "team from hell," without whom no author could have pulled this off. Tremendous regards are also due Lynn Ford, Susan Look, Jenn Nelson, and Mike VanMantgem for an unprecedented job of sales and marketing. Prima continues to prove that they are an unstoppable publishing force. It kind of makes you wonder if they have some hidden "god" codes of their own.

— Ed Dille  
Huntington, WV  
August 3, 1994



# INTRODUCTION

Welcome to Hell on Earth! How's that for an encouraging beginning to a book? Although you will find *DOOM II* a hellish experience, one can only hope that you will not feel the same toward this strategy guide. After all, I seek to lessen your burden. Is that not a noble effort?

*DOOM II: The Official Strategy Guide* arms you with all the basic knowledge and skills you need to rescue humanity. No matter how complete the intelligence briefing, mission execution is still in your hands, Marine. Timing and precision are everything. Slow down in a bad neighborhood and you die. Forget to look both ways before crossing the avenue and you die. Inhale when you should exhale and *you die!*

## THUMBNAIL STORYLINE

At the end of *Doom*, Our Hero, having returned to Earth, is left staring at a flaming city, evidence that the demon aggressors have arrived ahead of him.

It turns out that the monstrous invaders are all over the place. There are demons from Tokyo to Timbuktu, from Stockholm to Scranton. Many people are dead. Some people have been transformed into flesh-eating zombies, but some have actually survived. The remaining leaders of humankind have evolved a plan to save the human race. In orbit, they have built dozens of enormous ships to



## DOOM II Hell on Earth

carry all the remaining people into space, away from their ruined world. However, the only spaceport with sufficient capacity for these ships to land has been taken over by the demons. A small band of tough fighters is sent into the port to kill the demons and permit the ships to land and take on passengers. If you lose, all mankind is doomed.

Eventually, you manage to kill the demons guarding the spaceport, and find the master switch to turn off the flame barrier that prevents the ships from landing. You pull the switch, and the ships land. People file onto them as fast as possible, and they take off. Unfortunately, you are trapped in the room with the switch, and are unable to leave with the rest of humanity.

Now, you are the last human left on Earth. Everyone else is a zombie, dead, or in orbit. The High Command radios down to you and says that their sensors have determined that all the demons' power comes from a single spot. If you could find that spot and somehow close it down, they would lose much of their strength, and humanity could land back on the planet and begin to reclaim Earth from the demon horde. You must fight your way through the suburbs and slums of a ruined city, making your way to its very heart, where the monsters have raised a mighty citadel of evil.

You break into their stronghold and find the source of power. It is, of course, a portal direct to Hell. To close off the gate, you must go through the portal into Hell, and close it from the other side.

Without hesitating, you plunge through. Now, in Hell, you have to fight your way through the diabolic landscape to the center of Hell, where you find the master source of all power and destroy it, thus closing the gate to Earth and trapping the demons in their nether dimension. You are flung back out of Hell to Earth. Humankind is saved and the demons are thwarted.

Now you can have a donut.

## HOW TO USE THIS BOOK

Stand by, Marines, you are about to embark on a grueling course of training to prepare you for the life-or-death mission you have been given. We'll start out with the basics. First, you will be told how to maneuver in the *DOOM II* environment. You gotta learn to walk before you can run, right mister? HEY . . . I'm talking to *you* scumbag. Listen up!

Next, Sergeant Workman will instruct you in object recognition. Pay attention! You will only see this once before you go in, and I don't want to write a letter home to your mother explaining that you got your butt blown off because you couldn't remember the difference between toxic waste and a tripwire.

Now comes my favorite part, dirtballs . . . the weapons briefing. Think you're big and bad just 'cause you stumbled across a BFG 9000? I can hear you now.

"Oh yes, Drill Sergeant, Mama told me there'd be days like this. Bring 'em on, I'm ready to rock and roll."

That'll be just before you blow your own damn foot off.

Sergeant Workman will also teach you the ins and outs of every piece of hardware in the game. You will learn how to fieldstrip your weapons in the dark, clear jams, and reload on the run. When we're finished with you, gentlemen, you will be able to use your chaingun like a Ginsu knife and lob rockets like you were shooting layups back in Podunk. When we get done making you a lean, mean, killing machine, your Mama won't even know you. Can I get an *UUURAH, Drill Sergeant?*

Uurah, Drill Sergeant.

I can't *hear* you ladies!

**UUURAH, DRILL SERGEANT!!**

Right. After you've mastered the finer points of achieving peace through superior firepower, you will get your first look at the enemy. Make no mistake, they are about as baaad as they want to be, and you're playing on their turf, sweetcheeks, don't you ever forget it!

We will wrap the training session with a review of tactical fire and movement. This is the bread and butter of a grunt's life. Learn it . . . Live it . . . Breathe it. If you don't, you'll end up in one or more body bags on a plane back to Podunk. If you do, and you're a good little Marine who

remembers his Drill Sergeant before you go to bed each night, you just might—and I said might, mind you—survive.

Next will come the meat-and-potatoes, detailed intelligence and tactical briefings for the entire campaign. You will receive annotated maps and a fire and movement plan. You must commit this to memory, synchronize your watches, and execute it to perfection. There is no room for error, gentleman, nor will you have time to casually refer back to your maps once you've entered an area. To hesitate means death, as those of you with bloodstains in your manual may have surmised.

If you make it out the other side, and that "if" is entirely up to you, you will have the opportunity to face some of the people who put you in this predicament to begin with: the gang at id Software. No, no . . . save your questions for later. I have a feeling they will be more heartfelt by that point. Provided, of course, you're still in any shape to voice them.

That's it, Marines. Anyone who doesn't feel man enough for this mission should step forward now . . . so the rest of us can eat you alive. We'll *need* our strength.



## CHAPTER

# 1

## STAYING IN CONTROL

Alright, jarheads, the first indication you may get about things getting out of control is an inability to bring your tactical display up in the first place. No problem. Listen up here and we should be able to square that problem away.

### SYSTEM REQUIREMENTS

*DOOM II: Hell on Earth* requires an IBM-compatible 386DX machine or better, running DOS 5.0 or higher, with at least 4 megabytes of RAM, a VGA graphics card, and a hard disk with at least 20 megabytes free. For enhanced speed and better play value overall, a 486 or Pentium system with at least 8 megabytes of RAM is recommended. In fact, either of these latter choices is necessary to remain competitive in a head-to-head modem or network environment. All network play is supported only by the IPX protocol.

*DOOM II: Hell on Earth* supports the following sound cards: General MIDI, Adlib, Sound Blaster, Sound Blaster Pro, Sound Blaster

## DOOM II Hell on Earth

16, Sound Blaster AWE 32, Roland Sound Canvas, Gravis Ultrasound and Ultrasound Max, Wave Blaster, and equivalent compatibles. The game also supports keyboard, mouse, and joystick control, or a combination of any of the above. In practice, keyboard-specific control not only seems the most responsive, it also precludes stress-induced wear and tear on more delicate peripherals (mouse balls don't hold up well under constant fire from Barons of Hell and other nasties).

### INSTALLATION PROCEDURES

Follow the installation procedures that came with the game. If you experience any problems loading or configuring *DOOM II*, call Id's Technical Support Line. What's that, you don't have a shrink-wrapped version of the game? Hey dude. Tough, you're supposed to be a Marine, not a pirate.

### THE OPENING MENU

Once you have successfully booted the game, you will come to a screen that looks like this:



**Figure 1.1** You can access the Main menu at any time by pressing the **[Esc]** key.

## Chapter 1 Staying in Control

Use whatever control method you prefer to move the skull up and down and highlight the desired menu choice. Hit the **Enter** key, left mouse button, or joystick fire button to activate the option. Here are the options and what they do.

### **New Game**

This is fairly obvious. By selecting this option, you are asking to begin a new game, regardless of how far you may have progressed up to that point. You will start over with only a pistol and your fists to defend yourself. You do have a degree of selectivity over the difficulty, however. If your previous game was too hard, you can decrease the difficulty level. Conversely, if you are doing very well, you can stage your own Nightmares. You can choose from the following five levels.

### **I'm Too Young to Die**

And you probably still need rubber sheets. Don't let me catch any of *my* Marines wasting ammo at this level.

### **Hey, Not Too Rough**

Crawl back in the sandbox, ladies, you're not ready for the real world.

### **Hurt Me Plenty**

That's the spirit—no pain, no gain. This is a good place for you Boots to cut your teeth and get bloodied. All missions will start with this profile unless you specify otherwise.

### **Ultra-Violence**

UUURAH! This is where real men play. All your intelligence briefs and tactical fire and movement plans are generated for this skill level. If you wimp out and go tactical at lower levels, don't be surprised when things that look like they are going to be fun turn out to be just another boring shoot and loot.

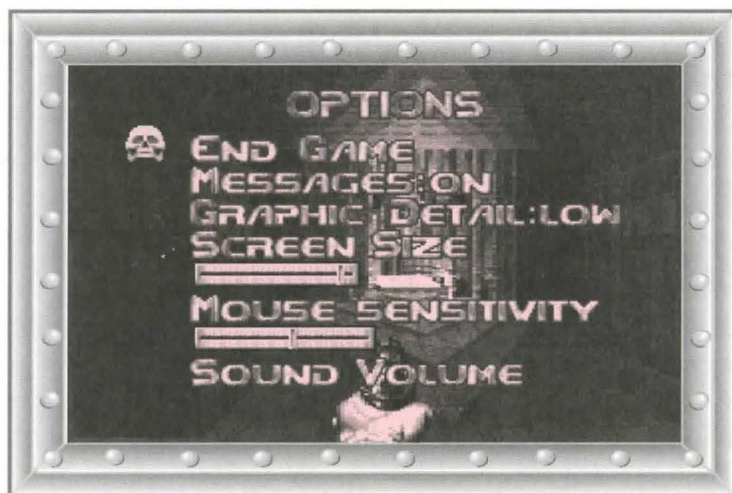
## Nightmare

Hey, even *my* mother told me not to play in this sandbox. It's *waaayy* too scary. The bad guys move twice as fast, shoot three times as often, and come back from the dead no matter what you do to them. It's like some kind of bad drive-in horror movie.

## Options

This is the place you want to go if you find yourself attempting to make do with antiquated equipment. If your tactical display (your computer) bogs down while you're running around in Hell, that's a bad thing. The Options menu gives you several alternative configurations to bring your display up to speed. The two with the greatest impact are lowering the size of the main display and reducing graphic detail from high (the default) to low. Play with both of these to find the best combination for your machine. Remember, however, the smaller your display size, the harder it will be to pick out those fine tactical details that just might mean the difference between life and death.

You can also adjust the sensitivity of your mouse, turn screen messages on or off, and set your sound level from the Options menu.



**Figure 1.2** Use the Options menu to configure the game to your hardware requirements.

## Chapter 1 Staying in Control

### Load Game

This is a place you *will* visit frequently, provided you had the foresight to save your games now and then.

### Save Game

This main menu selection saves a game in progress at your present location. Use this option often, particularly before attempting any of the difficult timing puzzles, many of which will require multiple attempts to complete correctly. You can save up to six different positions using this option.

### Quit Game

This is *not* an option for any of my Marines. Good Marines do not know how to quit. Give out, gentlemen, never give up.

## THE TACTICAL DISPLAY

This display is active all the time that you are tactical. Learn to use your peripheral vision to check this data while remaining focused on the enemy. The counter to the far left displays the ammo remaining in the currently selected weapon. It's always good to know when your clip is about to run out. Next to that, you will find the readout for your bio-monitor. Unenhanced, your maximum health rating is 100 percent. You can find augmentation while operating in the field, however, that can raise the maximum to 200 percent. For additional details on these items, see Chapter 2.

The next area contains the digits 2 through 7 above the word "arms." Don't get confused by the obvious, maggots. These correspond to your weapons slots, and they will not be highlighted or available unless you have found that weapon in the course of the mission. The only ranged weapon you begin with is the pistol. For additional details on this and other weapons, you will have to wait for the weapons briefing in Chapter 3.

## DOOM II Hell on Earth



**Figure 1.3** The tactical display contains all the information you might need at a moment's notice.

In the center of the display is the ugliest thing you will encounter in the entire campaign, a mirror. It will reflect your emotional and mental state throughout the firefight, and it is also a good indicator of the effects of various psychogenic enhancement drugs you may find on patrol. Don't spend too much time preening over yourself though, babies, or the bad boys will catch you napping. That shouldn't be a problem for you—none of you are worth much to look at anyway.

Just to the right of your ugly mug is the armor counter. This tells you how much protection you're wearing, from 0 percent to 200 percent. Remember, when you are running around without armor, it's the equivalent of traipsing naked through cracktown with \$1,000 bills taped to your body. Even when you are maxed out at 200 percent, however, you had better not get cocky. Four or five well-placed hits and the rest of us will still be trading face punches over whatever goodies you've stashed in your locker.

Just to the right of the armor display is a vertical bar with three slots. These are for the yellow, blue, and red keys, respectively. You will not be issued these keys—you must find them in the field. Further, the keys you find in one mission will not work in subsequent missions. The demons simply recode their access doors too quickly once they realize you've broken a level. As such, finding the keys to the various doors will be one of your primary tasks for each mission. Be aware, however, that not every mission profile will require the recovery of all three keys.

The final area on the tactical display is one of the most critical of all—your ammo inventory. This is a quick reference of all the “bullets and bombs” you are carrying, *regardless* of what weapon is currently active. The number to the left side of the slash corresponds to the amount on hand. The number to the right of the slash equates to your total carrying capacity for that ammo type.

## Chapter 1 Staying in Control

### QUICK START BASICS

Some of you are probably itching to get into combat already. If you are dead set on being that foolhardy, there is probably nothing I can do to stop you. Take a few pieces of advice, however, before you go running off to your death.

- Run over objects, including those left by enemy kills, to pick them up and add them to inventory. If you don't pick up an object on the first pass, chances are you either don't need it right now (for example, attempting to pick up a medikit when you're at full health), or you don't have room in inventory for the item (for example, trying to add a clip when your ammo counter is already maxed out).
- Remain aware of your surroundings at all times and check your maps frequently. You may get visual clues that will help you find hidden doors.
- When you press `[Spacebar]` to open doors, make sure your weapons are ready. You never know what is waiting on the other side.
- Never stand still and go toe to toe with the enemy if you have any other choice.
- Don't let them flank you.
- Watch for traps and tripwires at all times. You may or may not receive a visual clue to the existence of these items on the main display, but they sometimes appear as small squares or unusual rectangles on the overhead map. A good clue is when you see such an item on the map and cannot equate it to a physical object on the main display.
- When you find a teleport, you should not, as a rule, go through it immediately. First be sure you have fully explored the area you can currently access without the teleport before going through. Otherwise, you may not have a chance to turn back and pick up items that you missed.
- Unless you are a masochist, save frequently.
- Keep moving and make every shot count.

**DOOM II Hell on Earth**

If you follow these simple guidelines, you should manage to survive just long enough to realize that you have made a grave mistake. Don't worry, once they turn you into one of those damned zombies that seem to be running around all over the place, the rest of us will wave hello before we blow you away. This concludes the first module of training. Anyone who cares to drop out and go it alone may do so now. The rest of you break for chow and reconvene at 1300 hours sharp. Be there . . . aloha.



## CHAPTER

# 2

## NAVIGATION AND OBJECT RECOGNITION

Good Afternoon, maggots! My name is Sergeant Workman. I will be taking you through the next four courses of instruction in short order. I know your bellies are full from the fine chow you were just served, and at least some of you are having flashbacks to your kindergarten nap time. Rest assured, kiddies, anyone who falls asleep in my class will get to come up front to help me demonstrate one of the 27 ways to break a neck. Understood? Good, let's get started.

The first period of instruction will be split between two topics, navigation and object recognition. There will not be a break between them. Sorry, ladies, you'll just have to cross your legs and hold it until I'm done. First things first, let's find out if you babies are afraid of the dark.

## **BASIC NAVIGATION**

You will be operating under low light conditions most of the time you are in the field. Darkness can be an enemy or a friend, depending on how well you learn to use it. You may be operating on his turf but, in DeathMatch mode the enemy's vision is impeded as much as yours. Learn to seek out dark corners from which you can stage ambushes, and always look for him to be hiding in the same areas.

You will encounter a huge variety of terrain in the field. The more you learn to use terrain to your advantage, the greater your chance of survival. We will touch on a few such tactics in this lesson, then round out your knowledge of the tactical use of terrain during the course of instruction on fire and movement in Chapter 5. First, let's cover the basics of doors, switches, and teleports.

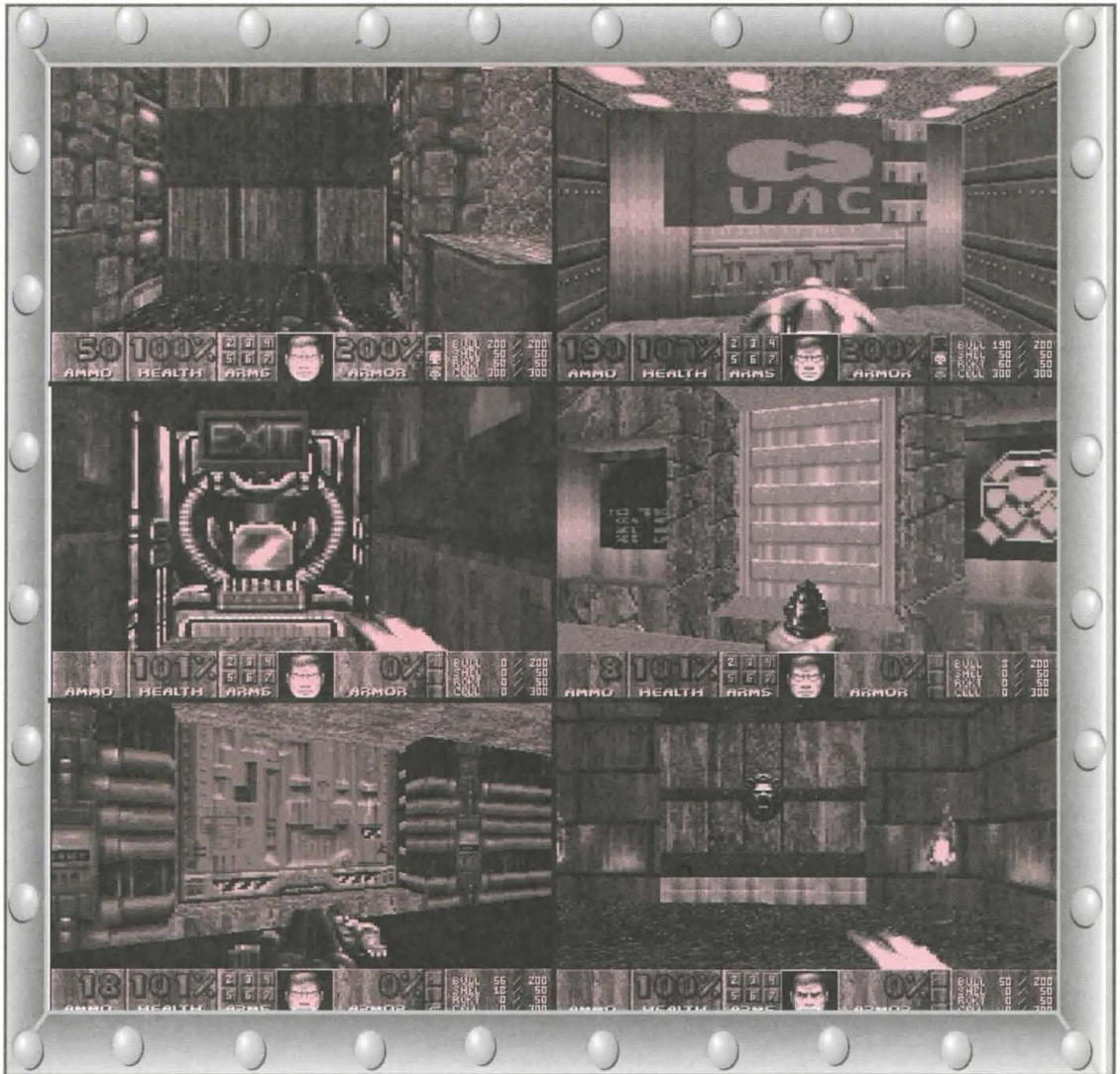
### **I'll Take Door Number Two, Bob**

Opening doors can reveal some much needed ammo and medical supplies, or a horde of hungry Imps. Although it's usually the latter, you won't find out unless you can get the door open to begin with. Unlocked doors will open when you press `[Spacebar]`. Locked doors can require a special key, the manipulation of a switch, or they may be one-way doors. The latter can only be opened from one direction and, if you happen to be on the wrong side, nothing you do will make a difference.

Figure 2.1 depicts the most common door types you will find in *DOOM II*.

Naturally, you should always pay attention to the clearly marked and well-lighted Exit doors. These are your R & R tickets, ladies, the only way you can get back for a little downtime on the beach. Don't believe you're scot-free once you've found these doors, however. There can still be some bad guys on the other side, so don't let down your guard.

## Chapter 2 Navigation and Object Recognition



**Figure 2.1** You will have to “kick the door down” a lot in DOOM II. Most of the doors you find do not require special handling, but some do. If you need a key to open a given door, a message will flash across the top of the screen informing you of that fact. If no key is needed, but the door does not open in the usual manner, it is either a one-way door or there is a switch nearby that will open the door.

## Switching Your Perspective

When you feel like you've run into a dead end, Marines, chances are you've probably missed something. That something is usually a switch. Switches perform a variety of functions in *DOOM II*, some of which may not be readily apparent when you activate or deactivate that switch. The one thing they have in common is that they all do something to alter your physical environment. Typical functions of switches include:

- Opening and closing doors, including secret doors (these can be either temporary or permanent alterations of the map)
- Raising and lowering elevators (temporary alteration)
- Raising and lowering platforms (permanent alteration)

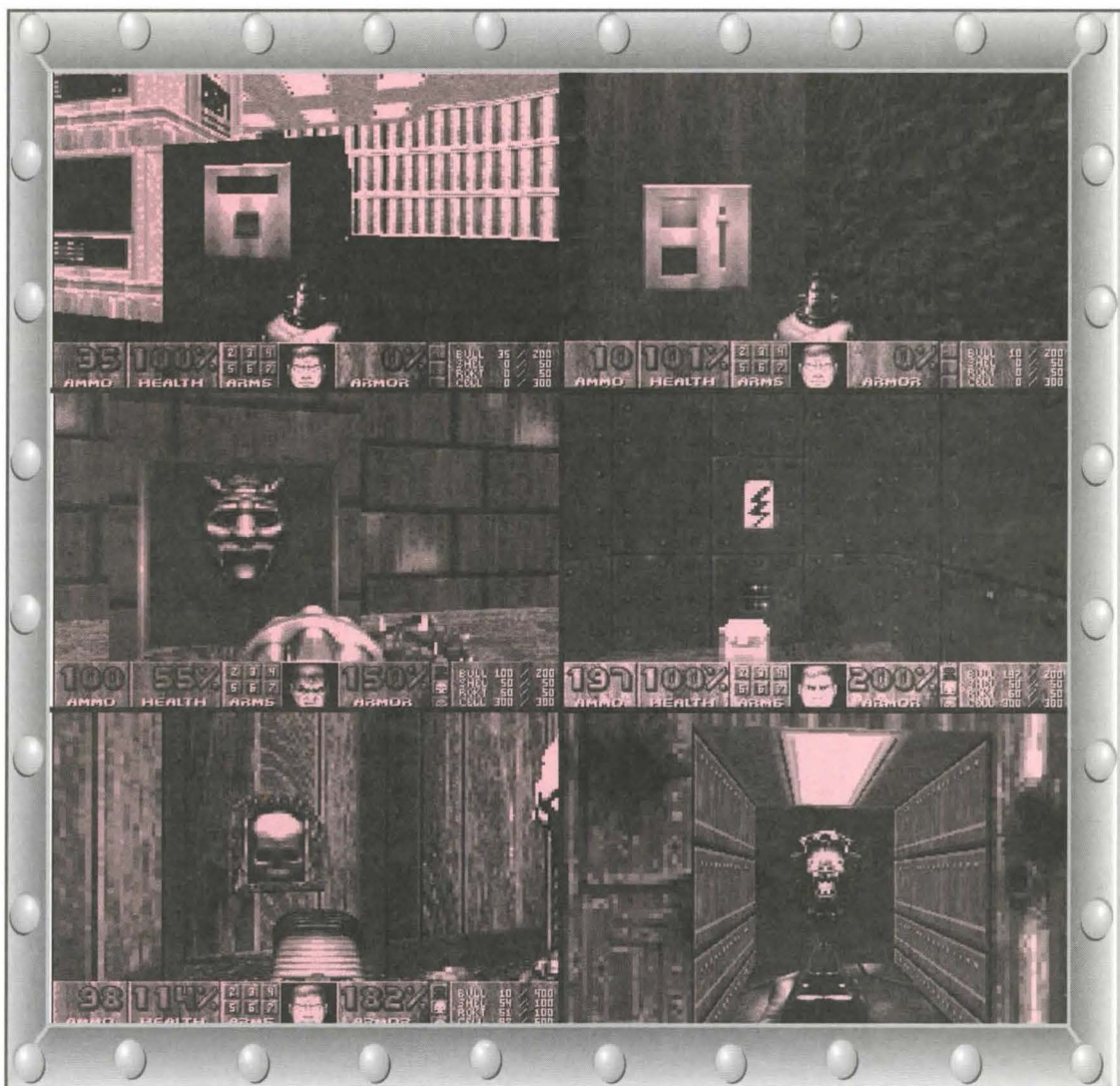
If you change the position of a switch, then go to your map view and nothing seems to have changed, you have probably happened upon a switch that creates a temporary alteration of the terrain. These form the heart of most of the timing puzzles you will encounter. The following situational excerpt from actual game play illustrates how these types of puzzles work.

You step off a high ledge into a pit. At the bottom of the pit is a switch. When you hit the switch, a door to the north opens, releasing a Baron of Hell, then closes again immediately. After you kill the Baron, which is fun in a small closed pit, the full nature of the timing puzzle becomes evident. You must hit the same switch again to reopen the door, run into the north room and hit two other switches on the west and east walls, respectively (which lower an elevator platform on the south side of the original room), then rush back out the door before it closes and across to the elevator platform before it raises back up.

*DOOM II* is riddled with puzzles like this. Timing and coordination are everything, as many of these puzzles require you to rush from one area to the next at full speed (with the **[Shift]** key depressed) to make it in time.

Figure 2-2 depicts some of the common switch types you will find in *DOOM II*.

## Chapter 2 Navigation and Object Recognition

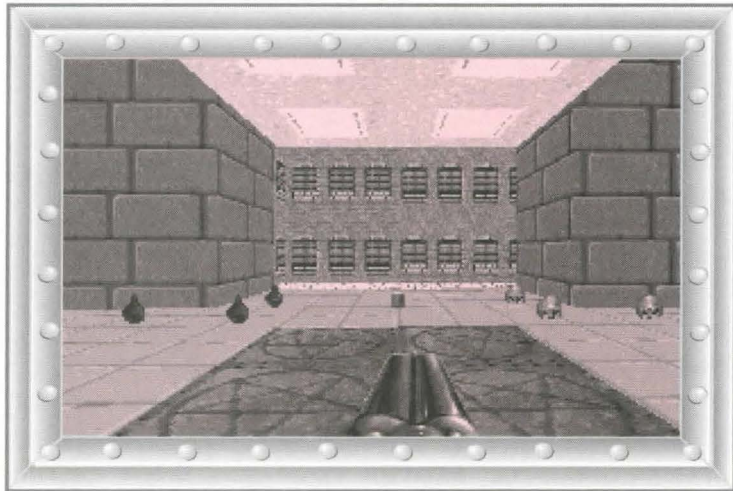


**Figure 2.2** When you activate a switch, the physical appearance of it will change in some way. Lights come on or go off, the position of a lever or sliding bar changes, or a closed eye opens. The exceptions are “face” switches like the demon heads. These are generally found on the outside of doors or elevator platforms and, when “depressed” via **[Spacebar]**, they cause the mechanism to move immediately.

## Teleports: The Express Train to Hell

The only exception to the aforementioned dead-end rule has to do with teleports. The instant you step on them, teleports take you into new areas of the level. Teleport travel is a necessity to complete most of the missions you will be given. It is also the fastest way to jump out of the frying pan and into the fire. You *will* be greeted by a welcoming party on the other end, only they will be looking at you like an hors d'oeuvre tray. As such, it's a good idea to have a little more firepower in your hand than what God gave you when you step onto a teleport.

Generally, teleports appear as flashing red pentagrams on the floor, and they may be surrounded by one or more candles. If you find a gray pentagram, it may be an exit to the current level as well. If you are boosted up with items and ammo, go ahead and take the exit. If not, you may want to go back and stock up a bit before proceeding to the next level.



**Figure 2.3** Teleports are the express train to Hell. Don't go into one of them unprepared.

## Chapter 2 Navigation and Object Recognition

### OBJECT RECOGNITION

You will encounter hundreds of objects in the field. Your survival depends on recognizing each of them and immediately understanding their tactical benefit or danger to you. I know that the use of the word *hundreds* has some of you concerned, probably those of you in the back row with the bulging eyebrows and sloped foreheads. Don't get your panties in a wad, peabrains. I will group them in categories even you should be able to keep straight.

#### Maps

As you move through a level, your Automap (which is accessed via the **Tab** key) will update itself to reflect where you have been so far. Your position on this map is depicted by a white arrow, the tip of which denotes the direction you are facing. Pressing **Tab** again returns you to normal view. The Automap feature is nice, but being able to see where you haven't gone yet is even nicer. To do this, you need to find a computer map.



**Figure 2.4** Computer maps like this one are not available on all levels, but they are extremely helpful for tactical planning when you do stumble across them.

Once you have a computer map of the level you are currently on, you also call it up with the **[Tab]** key. The difference is that this map contains a view of the entire level, though maybe not on one screen. To find out how to view more of the map, see the “Magnification” and “Follow Mode” sections below. On the computer map, areas that you have not yet entered are grayed out, but still visible. Use this knowledge to guide your exploration and tactics. Look for unusual structures or other visual clues to secret doors, traps, and tripwires.

### **Magnification**

Whether you are using a computer map or the Automap feature, you can increase or decrease the scale of the map by pressing the **[+]** or **[-]** keys, respectively. Zooming in will often reveal fine details about the particular room you are in that are not apparent at smaller levels of magnification. When you zoom out, more of the level will be revealed, but the entire level still may not fit on a single screen. When this is the case, you must also disable “follow mode” to scroll the rest of the map into view.

### **Follow Mode**

Under normal operating conditions, follow mode is enabled. This means that, while you are in map mode, if you use the directional arrows to try and scroll the map, you are actually moving in the environment. If you press **[F]** to disable this mode, you can scroll the map with the arrow keys or your mouse while the arrow icon, which represents your position, remains fixed in place. Press **[F]** again to return to normal movement.

### **The Tactical Grid**

Another method of getting your bearings in complicated levels is to use the tactical grid overlay. The grid, which is toggled on or off via the **[G]** key, assigns a Cartesian coordinate number (an x,y position) to everything, including your position. Used in conjunction with the computer map active and follow mode disabled, you can go anywhere on the map and note the grid position for future reference, should you so desire.



## Chapter 2 Navigation and Object Recognition

### Positional Marks

Finally, should you have a need to remember where a critical object might be found at a later date—such as a box of ammo that you did not have room for when you found it—you can mark the position of that item electronically on your map. Press **[M]** to mark your present location, and it will be assigned a numerical locator digit between 1 and 9. Only nine such locations can be noted on a given level at any time, but you can also clear marks to restart that sequence by pressing **[C]**. In practice, nine marks are usually sufficient for all but the most unorganized jarheads.

### Keeping Up Appearances

As you know, the Marine Corps not only expects you to think smart and fight smart, you must also look smart while you are doing so! I realize this may be difficult for some of you, but you have no option. If you look sloppy, you will fight sloppy, and I *will not* tolerate that from any of my Marines. Understood?

Good! Now, here is what the well-dressed Marine will be wearing for the fall season in Hell.

### Body Armor

You will find two types of body armor scattered throughout the levels. Green ones boost your armor rating to 100 percent, which is nice until you must stroll “across a crowded room.” Blue armor boosts you to 200 percent, which is usually enough for a small margin of comfort for a little while. Remember, however, you will still take some damage to health and armor when you are hit, regardless of which type you are wearing.



**Figure 2.5** There is nothing like a good flack vest to alleviate some of the worries of the world. These little babies come in two flavors: Good and Better.

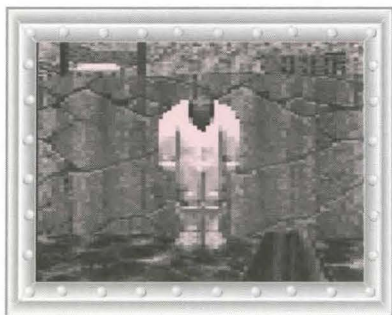
### Spiritual Armor

Spiritual armor appears as helmet icons. Each one of these that you find adds 1 percent to your overall armor rating, even above the 100 percent

and 200 percent ratings provided by the body armor. The order in which you obtain these two items has a bearing on your final armor rating. If you pick up five spiritual armors, then a green vest, the latter will override the spiritual armor, and you max out at 100 percent. If you are in a room with the same body armor and five spiritual armor icons, for example, pick up the body armor first, then the spiritual armor, and you will be at 105 percent.



**Figure 2.6** These little “party hats” add a 1 percent bonus to your armor rating for every one you pick up.



**Figure 2.7** Occasionally, you have to deal with some real slimeballs. That’s when a good rad suit comes in handy.

### Radiation Suits

OSHA may not like it, but to get this job done you’ve got to play with a little toxic waste now and then. Hey, don’t complain about it, the world doesn’t need any of you kids anyway. You do need to live long enough to get the job done, however, and that means finding and using these rad suits to navigate through the numerous radioactive pools and pits you will encounter.

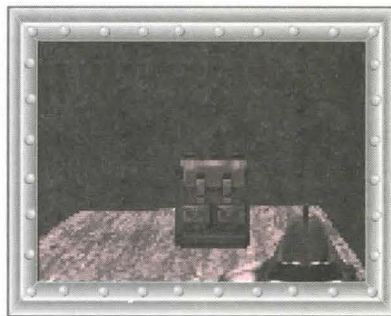
Look over the edge of any pits you find a need to go in. You might see one of these suits hanging nearby for the convenience of passing Marines. If you do, try to maneuver yourself so that you will jump right into the suit when you hit the pool.

## Chapter 2 Navigation and Object Recognition

Once your suit is on, your view will be tinted green to indicate that the suit is actively protecting you. This protection only lasts 60 seconds, so don't dawdle around practicing your backstroke in the slime puddles. When your time is almost up, the view screen will begin to flash. This means *everybody out of the pool!* Got it?

### Backpacks

Backpacks are rare but, when you find them, you can almost bet you are going to need them. In addition to doubling the total amount of ammo you can carry for each weapon, backpacks also come prestocked with 10 bullets, 4 shells, 1 cell, and 1 rocket.



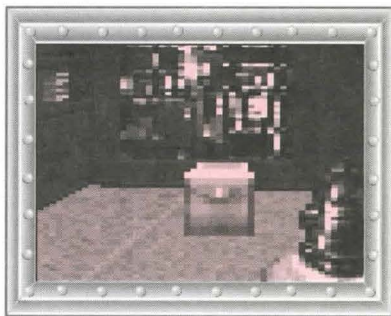
**Figure 2.8** Here's a little something to "lighten your load." Backpacks double the maximum capacity of ammunition you can carry, which means they are invaluable finds in a tight spot.

### An Apple a Day Keeps the Demons at Bay

The Marine Corps believes that your personal hygiene and overall health is critical to battlefield performance. In other words, we don't want you pantywaists crapping out from a staph infection because you didn't take the time to bandage those little cuts and bruises. If you're gonna win, you gotta be *strong*. And you can't be *strong* if you aren't *healthy*! Fortunately for you, there are some items you can find to aid this goal.

### Stimpacks

Stimpacks are nothing more than a glorified first-aid kit, so don't expect to stop any sucking chest wounds with this one (use the cellophane from your cigarette pack for that little annoyance and keep fighting). They will give you up to a 10 percent boost in health but, if your health is low and this is all you can find, take two aspirin and call me from the grave.



**Figure 2.9** Need a little boost? This first-aid kit won't go far, but it's a fairly common find.

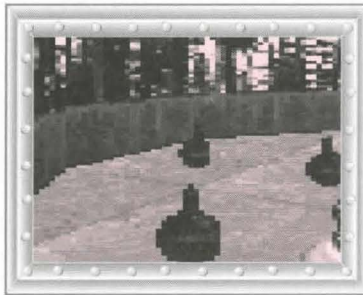
**Figure 2.10**  
DOOM II's  
answer to a tent  
revival preacher  
... these babies  
can HEAL you!



### Medikits

In need of a quick transfusion and a change of bandages? If so, a well-stocked medikit is the thing to find. Crack the top on these bad boys and you can restore up to 25 percent of your health instantaneously. Trust me, that beats a sharp stick in the eye any day.

**Figure 2.11**  
Finding these  
little flasks can  
be like getting  
manna from  
heaven.



### Health Potions

Blue health potions work very much like the spiritual armor icons. Each one increases total health by 1 percent, but they can increase health above the maximum as well. In other words, use up any stimpacks or medikits in the room before picking these items up.

**Figure 2.12** Are  
you mad enough  
yet? Do you  
want to tear the  
baddies apart  
with your bare  
hands? With a  
berserker pack,  
you can!



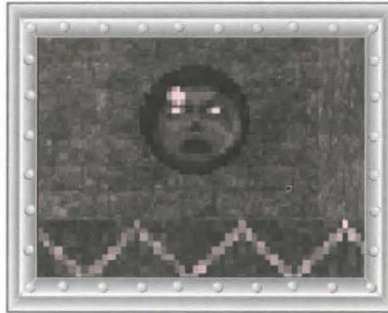
### Berserker Packs

Some things in life are just better than having sex. And finding a berserker pack is definitely one of them. Not only will it yank you back to full health in a jolt of adrenaline, it will also pump you full of quick-acting steroids. With those in your system, it really is time to rock and roll. This effect only lasts until the end of the level, or until you die. All the capillaries in your eyes burst at once and your vision turns red for the remainder of the level. As a "supermaggot," you will be able to run faster, jump farther, and squeeze the life out of nearly anything you run across. Put those weapons away, boys, and save the ammo for later. Put on those spiked brass knuckles and watch the Imps fly backward in a shower of blood spray! God, I love my job, gentlemen! UUUUURAAH!

## Chapter 2 Navigation and Object Recognition

### Soul Spheres

Have you eaten so much demon flesh that indigestion has got you down? Or maybe you've come down with a sudden loss of bladder control induced by a Mancubus. Either way, nothing calms your nerves and gets you back on track faster than finding a soul sphere. These goodies boost your health rating by 100 percent straight out of the chute, up to a maximum of 200 percent. It's like eating 27 cans of Kal-Kan, dogface. You will look and feel like a new man!



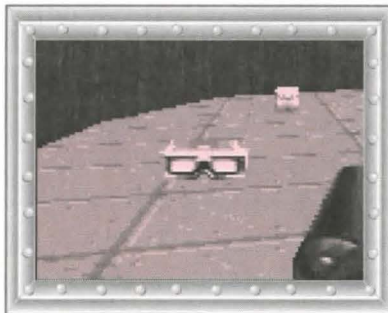
**Figure 2.13**  
*"With a little bit of Soul, you can ..."*

### Odds and Ends

Weapons and ammunition, which are a big part of the items you will find, will be covered in Chapter 3. That leaves just a few odds and ends to wrap up this part of the lesson. There are two big odds and just one little end, however, so don't fall asleep just yet, girls.

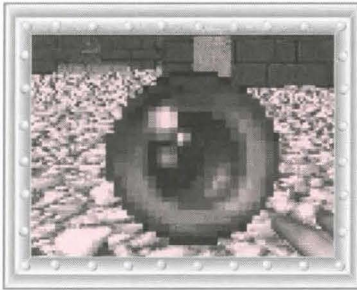
### Light Amplification Goggles

Face it, a lot of the places you will have to operate in are just not well lit. I guess there aren't that many interior decorators in Hell . . . go figure. Anyway, if you pick up a decent pair of these goggles, you will be a lot less surprised when something nasty tries to sneak up on you. In fact, these will give you the tactical advantage if you stay at a distance where you can see the enemy but he can't see you. Unfortunately, most of the batteries in these units can't stand the acrid fumes in the levels, so the effect only lasts 120 seconds.



**Figure 2.14** *I can see clearly now, the pain is gone. Light amplification goggles will keep you from nasty bumps in the night.*

**Figure 2.15**  
Blur artifacts make you partially invisible for 60 seconds.



### Blur Artifacts

Blur artifacts are not common at all, and you almost wish you could save them up to use at a later time . . . but you can't. When you pick up a blur artifact, you become semi-invisible, much like a Specter demon. Opponents may still have a rough idea where you are, but the effectiveness of their attacks is reduced considerably. Use blur artifacts either to get in some timely attacks or get the hell out of Dodge quickly, for the effect only lasts 60 seconds.

### Invulnerability Artifacts

**Figure 2.16**  
Pick up one of these and "you can't touch this." If you have ever wanted to thumb your nose at a Cyberdemon, now is the time to do it.



The power of an invulnerability artifact is so strong that your vision will go negative for the duration of its effect, which is 30 seconds. This is your "moment in the sun," maggots, take advantage of it! While you are invincible, it is up to you to inflict as much pain as possible. Trust me, when you've got them by the curlies, their hearts and minds will follow.

### The Megasphere

These glowing silver balls are a godsend in the later missions. Pick one up and your health and armor both immediately shoot up to 200%.

## THAT'S A WRAP

This concludes your briefing on objects. While you are on patrol, your objectives with regard to them are threefold: find them, cherish them, and use them wisely. Satan doesn't give second chances, and neither do his playmates.

## CHAPTER

# 3

# PEACE THROUGH SUPERIOR FIREPOWER

Welcome back, devil dogs! Our next course of instruction will be on weaponry. Please do not refer to them as guns. If you do not know the difference, stay after class and I will explain it to you, dipdunk. Weapons are like any other tools. If you use the right one for the job, things will go smoothly. If you don't, you won't have the opportunity to make the same mistake twice.

## THE WEAPONS

Each of you will be issued a standard service handgun and 50 rounds of ammunition at the beginning of the mission. Though reliable, these pieces do not pack much stopping power. Consider them to be effective against all varieties of Former Humans and of marginal use against Imps and Demons. Their greatest strength is that they have a



**Figure 3.1** *The handgun offers minimal stopping power, but it beats the hell out of duking it out.*

reasonable rate of fire. The weapon is a semiautomatic and will discharge just as fast as you can twitch your finger.

Lesson number one for the pistol, maggots—never shoot an enemy just once, then stop to see how good you were. Double tap everybody at a minimum, then follow up as necessary. Once they go down, immediately acquire your next target and repeat the procedure.

Lesson number two, and this one applies to all your weaponry—*always* aim center of mass on the target. Focus your eyes on the front sight of your weapon, not downrange. You will know when you are doing this correctly because potential targets will seem slightly out of focus. That's alright, don't try to bring them back into focus, or you will lose track of where the hell you are aiming. When the largest part of the target moves in front of your sight picture, *squeeze* off a round and you should be shooting dead-on center of mass. Don't jerk the trigger or you will pull your shots off target.

## Shotgun

Shotguns were the weapon of choice for close quarters work in Vietnam. Their effectiveness in that respect has not diminished in the least to this



## Chapter 3 Peace Through Superior Firepower

very day. They feed easy, never jam, and throw up a wall of lead that mows down most lesser enemies, including Imps, Demons, Specters, and all varieties of Former Humans.

The shotgun will be your minute-by-minute workhorse on most missions. Upgrade to one as soon as possible and always keep it handy. There are two models of shotguns available in *DOOM II*.

### Pump Shotgun

The pump shotgun should be considered your trustworthy traveling companion and, for those of you who are veterans of the original *Doom* campaign, it will probably feel like finding an old lover. Each shotgun that you recover off of fallen opponents comes with four shells. The ones you find stashed generally have eight shells. Because of the limited amount of ammunition, it is imperative that you make each shot count. The only other drawback of the shotgun is that it kicks, which means you will have to recover your sight picture after each shot, resulting in a slower rate of fire than other weapons.



**Figure 3.2** Learn to trombone the action on one of these babies and you can lay down some solid covering fire.

### Combat Shotgun

This weapon is a new acquisition to the Marine Corps inventory and some of the troops have taken to calling it the “supershotgun.” It uses the same ammo as the pump shotgun, but at twice the rate. It also kicks twice as bad, which doubles your recovery time between shots. On the upside, however, it offers three times the stopping power. If you want to let the air out of floating



**Figure 3.3** It's two, two, two times the fun! But the combat shotgun is three times as powerful as its little brother.

## DOOM II Hell on Earth

gasbags like Cacodemons and Pain Elementals, stick one of these in their eye sockets and pull the trigger. Sayonara slimeball!

**Figure 3.4** Think of the chaingun as a big street sweeper. Just spray the infected areas with lead and everything will be all better.



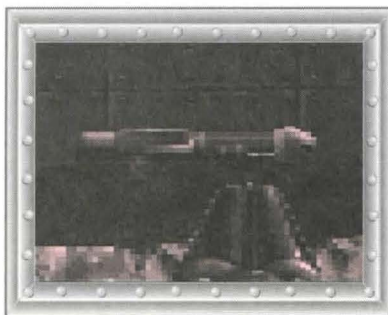
### Chaingun

I don't know about you but I *hate* crowds, especially the hostile kind. When you find yourself in an unexpected riot, a chaingun can be the great equalizer. Simply squeeze the trigger and wave the damn thing around. Let God sort them out when it's over.

The greatest strength of the chaingun is its rate of fire, which is also its biggest weakness. You can sling a lot of lead in a short amount of time when you need to, but those bullets have to be replaced as well. When you pick up a chaingun from fallen enemies, it will come with 20 bullets. But it's always a good idea to horde bullets away whenever you can.

If you are really accurate, you can use your chaingun like a surgeon as well. Draw a bead on a Pain Elemental, for example, and keep your finger on the trigger. The constant spray of bullets will damage him but, more importantly, it will also keep him distracted and prevent him from working up the energy to spit out lost souls at you.

**Figure 3.5** Rocket launchers give you the ability to reach out and "touch" someone.



### Rocket Launcher

Ranged attacks can come in very handy at times. Want to clear a high ledge of five or six pesky snipers? Here is the ticket to do that job. Make sure you're out of range of the blast, however, or you can take some damage as well. *Never* use a rocket launcher in close quarters unless it's your last great act of defiance.

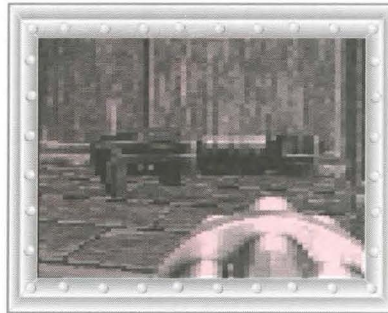
## Chapter 3 Peace Through Superior Firepower

Rocket launchers are preloaded with two rounds, but you can find a limited number of reloads scattered here and there in the levels. You *must* make every shot count when using a rocket launcher because some of the bigger beasts can absorb quite a few of them before going down. Barons of Hell take 5 direct hits and Cyberdemons require 20 hits. Now *that* is scary.

### Plasma Rifle

Think of the plasma rifle as big brother to the chaingun. It also consumes ammo at a prodigious rate, but each shot is much more deadly. Plasma rifles use energy cells as ammo. Because replacement cells are quite rare, don't waste precious plasma shots on enemies who can be killed with lesser weapons.

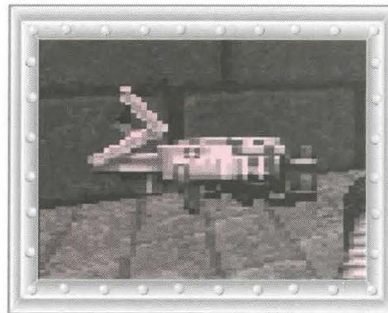
To place the power of this weapon in perspective, it takes about 10 plasma hits to equal 1 rocket hit.



**Figure 3.6**  
*Plasma rifles can liquefy the enemy, but only if you've conserved your ammo for when it is really needed.*

### BFG 9000

Just what does the BFG in the nomenclature for this weapon refer to? I'll leave that up to your discretion, as if you pukes had any. The BFG 9000 is simply the finest assault weapon money can't buy. You can't *buy* the respect one of these babies will bring you, you've got to *earn* it.



**Figure 3.7** *"Oh yes, you've found the BFG 9000!"*

Each time you discharge this behemoth, it eats up the equivalent of two entire energy cells, but it only takes one direct hit from a BFG to send a Baron of Hell back where he came from. His big brother, the

## DOOM II Hell on Earth

Cyberdemon, is banished with four solid BFG blasts. If there is a downside to using this weapon, we haven't found it.

**Figure 3.8**  
*There's nothing better than a good old two-cycle chainsaw when you've got some wet work to do.*



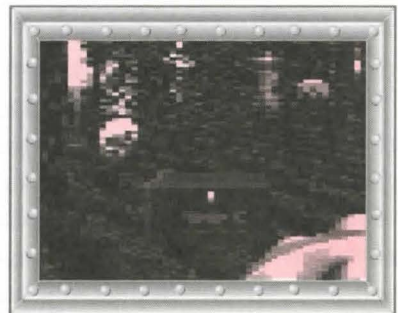
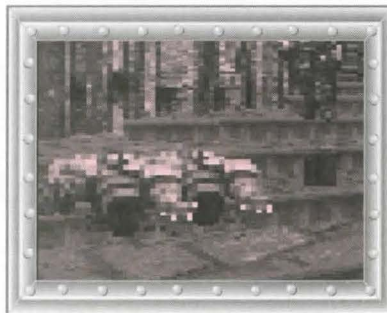
### Chainsaw

Hey, face it, if it was good enough for your mother, it should be good enough for you. Once you've found a chainsaw, it becomes the weapon of choice for up close and personal wet work against Imps, Demons, and Specters. Remember, however, you can only saw them in half one

at a time, so don't let your current victim's buddies flank you while you're busy. A toast to the vanquished: Here's blood in your eye!

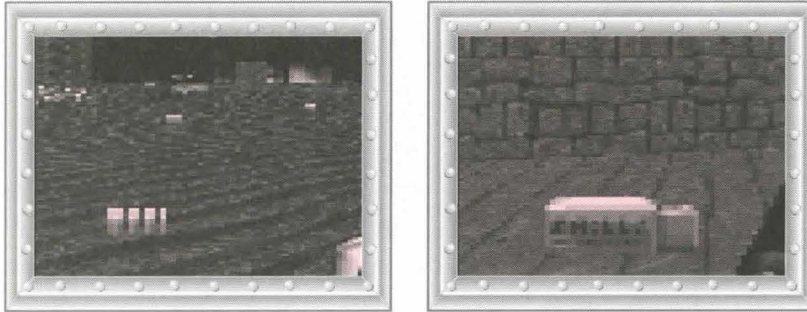
## THE AMMO

One of the big problems with urban overcrowding is that there never seems to be enough ammo to go around. Scavenge all you can from your dead enemies but always be on the lookout for secret stashes that others have left behind as well. Learn to conserve ammunition whenever possible, but don't hold back when it looks like your position is being overrun.

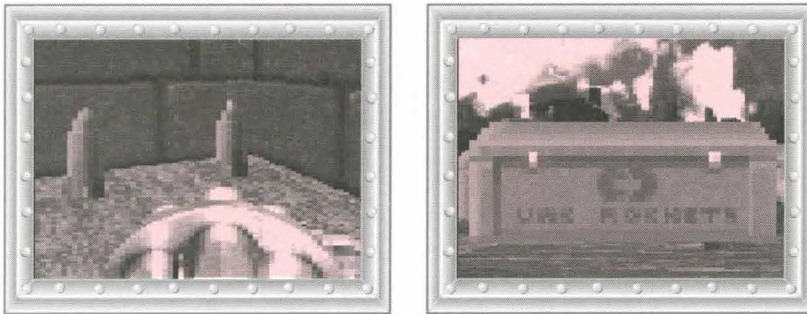


**Figure 3.9** *Bullets can be found in two quantities. Clips, which are frequently left behind by dead enemies, contain five bullets. Ammo boxes contain 50 bullets.*

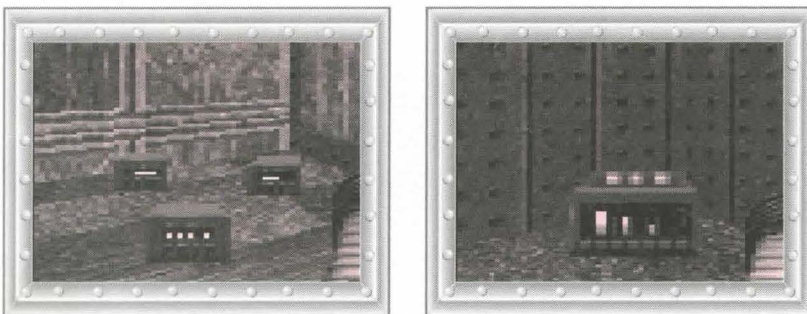
## Chapter 3 Peace Through Superior Firepower



**Figure 3.10** Shotgun shells are found in small bandoliers of four shells and standard paper cartons of 20 shells.



**Figure 3.11** Rockets are in short supply. You will find them as individual shells and, occasionally, in cases of five rounds.



**Figure 3.12** Energy cells are used to power both the plasma rifle and the BFG 9000. One cell equates to about 20 rifle shots or one-half of what you need for a single BFG blast. Bulk cells contain the equivalent of five individual cells: 100 plasma shots or two-and-a-half BFG blasts.

**TACTICAL RECAP**

Know your weapons, both how to use them and what to use them on. Always focus on your front sight and shoot to *kill*, not to wound. Fire center of mass on all targets. You should pick up blood spray that confirms you are being effective, even without refocusing on the target. Conserve ammo when you can, but not at the expense of losing the battle. It doesn't make sense to die with full bandoliers. If it looks like you are going down regardless, take as many of the SOBs with you as you can.

## CHAPTER

# 4

## THE BESTIARY

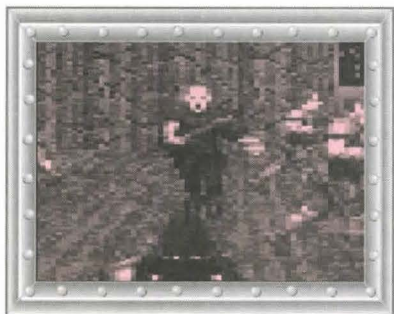
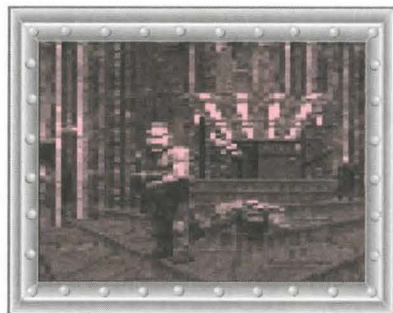
Well, kiddies, now it's time to meet what you are going up against. If any of you feel a sudden urge to leave the room in the middle of this briefing, *don't*. Just go where you are and wallow in it. You might as well get used to a little extra weight in your boots and lightness in your bowels now, because you will feel this way again.

### PLAY IT AGAIN, SAM

If you thought you had gotten rid of them, you were wrong. All of your old *Doom* playmates are back for the sequel in greater quantities than you've ever seen before. Don't worry, you won't run into a Cyberdemon around every corner (thank God), but you will see a lot more of those you feared most in the last outing. What's worse is that they will not be your biggest fears this go-around.

### **Former Humans**

These guys are basically clueless and weak. Hey, *you* might see someone you know out there. They wander around like rejects from a George Romero movie and take potshots at you if you are stupid enough to stand still for them. If one of them hits you, your armor and health decrease between 1 percent and 15 percent, depending on where you get hit. One pistol round to the brainpan and these guys go belly up. Their corpses are a nice place to find some ammo, however.



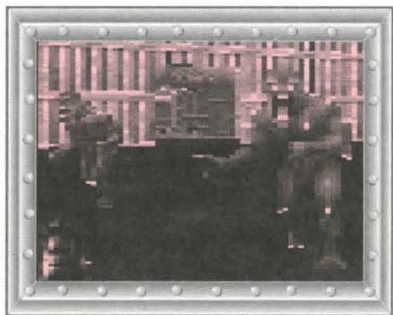
### **Former Human Sergeants**

A little more of what you would expect from a former Marine, these zombies are a bit faster on the draw than their privates, and they also pack shotguns. If you get clipped by one of their shots, you will take between 9 percent and 45 percent damage to health and armor, depending on how far away you are at the time you get shot and the percentage of the pattern that hits you.

Keep moving to avoid their fire and learn to return fire on the run. Two rounds to the vital areas or a clean shot to the head will usually silence these enemies. When things calm down, make sure you loot their bodies for all the shotgun ammo you can carry.

### **Imps**

Despite their cute name, these little devils are nasty, especially in quantity. From a distance, they hurl fireballs at you, one right after another, each of which can do between 3 percent and 24 percent of burn damage to your





## Chapter 4 The Bestiary

health and armor. If you manage to avoid these and get right in their faces for a little wet work, they can still rip you to shreds with their razor-sharp claws. When there are lots of Imps and you have little room to maneuver, well-placed shotgun blasts can keep them at bay. When there are only a few, use the chainsaw to “burger-ize” them.

### Demons

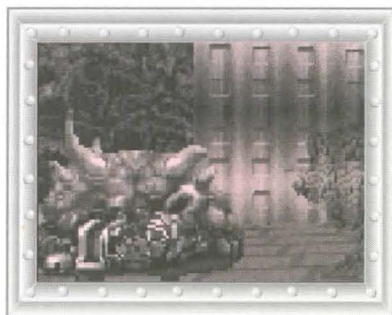
Imagine a pink bull with a mouthful of razor blades that walks erect and looks very pissed. That, young man, is a Demon. The best thing about Demons is that they do not have a ranged attack, they have to get right in your face to eat you. Unfortunately, if they do get the opportunity to take a healthy chunk out of your butt, count on 4 percent to 40 percent damage, which is one helluva love bite.



Demons are slow and easy to kill with a couple of shotgun blasts, but you should back peddle away from them while you are firing those rounds to preclude a lucky hit in between your shots. If you step on a tripwire that releases multiple Demons, run backward, firing as you go, or lure them down a narrow passageway so that they stack up behind each other and cannot flank you. Then break out the chainsaw and hack your way back to daylight. Demons also seem to have trouble navigating stairs, so use these terrain features to your advantage.

### Specters

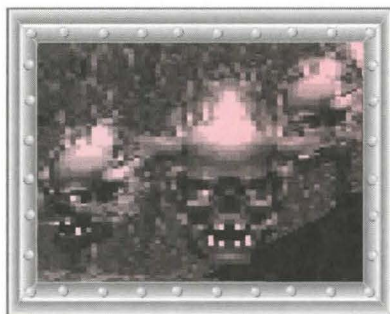
Now you see them, now you don't. Specters are not completely invisible, but they can be nearly so in a dark room. If sufficient light exists, you will be able to pick up the faint, flickering outline of a Specter in front of you. Shoot first and ask questions later. Aside from their partial invisibility, Specters are almost identical to Demons, with the same 4 percent to 40 percent bite attack, and they can also be dealt with in the same way as their more visibly irate cousins.



### Lost Souls

These flaming skulls are the tiki lanterns the demons have put up for the party they are hosting in your honor. Their method of attack is to hover overhead for a brief period (which is when they are the most vulnerable to a well-placed series of three shotgun blasts), then dive down to bite and burn you.

Each such attack will do between 3 percent and 24 percent damage to your health and armor. Don't stand still and they will have a harder time coordinating their attacks. In addition to appearing naturally, these monsters are also spit out of the mouths of Pain Elementals.



### Cacodemons

These beasties kind of remind me of your sister. They are one-eyed, snaggle-toothed gasbags that couldn't find a date if their lives depended on it. Of course, if you have anything to say about it, they will get a date with destiny. Cacodemons float majestically over the battlefield and, if it weren't for the fact that they are so damned deadly, you could almost think of them as graceful.

Cacodemons have two primary methods of attack. They can hurl balls of blue lightning at you from a distance, any one of which can turn your boots into ashtrays, or they can bite your head off for between 6 percent and 60 percent damage up close and personal. To keep them from building up enough energy to let loose with the lightning attack, keep hosing them down with either a chaingun or plasma rifle. If they insist on making it personal, stick your chainsaw between their teeth and fire that baby up.

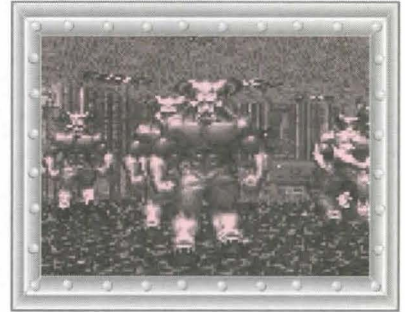


## Chapter 4 The Bestiary

### Barons of Hell

These nightmares may not be everywhere in *DOOM II*, but they will turn up a lot more often than you would like them to. Try to snipe at them with a rocket launcher from a position of cover if you can. It will take five direct hits to take them out, provided you are carrying that many rounds. Alternately, you can spoil their day with 50 shots of highly potent plasma or a single BFG 9000 enema.

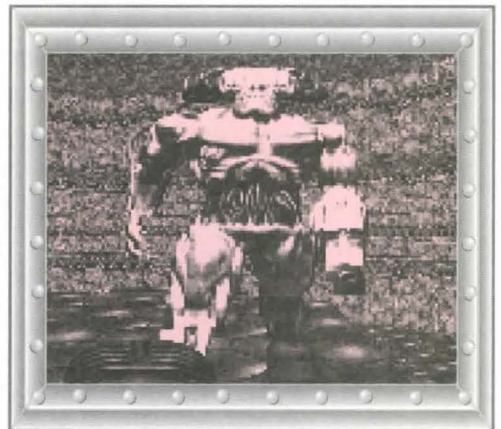
The problem is, they don't want to stand still for the kind of rough handling you have to give them. If you try to deal with them from a distance, expect a constant barrage of return fire not unlike that of a plasma rifle. Each one of these searing energy blasts can toast your hide for between 8 percent and 64 percent of health and armor. Also, if you are unlucky enough to get caught in close quarters with a Baron (which happens at least once in *DOOM II*), he will bat you back and forth between his claws to the tune of 8 percent to 80 percent damage per round at bat.

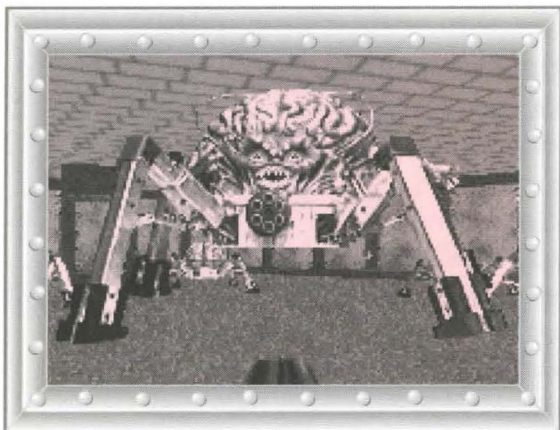


### Cyberdemons

Be afraid, be very afraid. These bionic beasties are half monster, half machine, and all murderous mayhem. They attack with a deadly accurate rocket barrage and every hit can strip up to 160 percent of your health and armor. In other words, if you can avoid the encounter at all, run like hell in the other direction. Luckily, this monster is so HUGE, he usually won't be able to follow you down the narrow passageways.

If you must fight him to get where you need to go, good luck! The best solution is to lure him into a cross fire from other nearby bad boys, such that the fallout of their attacks will weaken him. Without the benefit of this "friendly fire," it takes either 200 plasma shots, 20 rocket hits, or four direct BFG blasts to topple this titan.





## The Spider Mastermind

Daddy longlegs doesn't show up often in *DOOM II*, and when he does you often have some alternate methods of killing him. For the full details on those encounters, refer to the intelligence briefings contained in Chapter 6.

The boss spider has a chaingun imbedded in his face, but he has to spot and acquire you before he can fire. Fortunately, he often seems preoccupied with other matters, and is not the best at tracking a fast-moving target. Once you learn to control fluid fire and movement, this guy is actually a lot easier to polish off than the Cyberdemon. It takes either 150 plasma hits, 15 rockets, or three BFG 9000 blasts to unravel this guy's evil web.

## NEW ADDITIONS TO THE DOOM ZOO

Because no one is ever happy leaving well enough alone, the gang at id just had to eat late-night snacks and program their nightmares for our viewing pleasure. The new monsters, as a whole, are more fearsome than their predecessors. Oh well, I guess we'll just have to grin and bear it.

### Mancubus

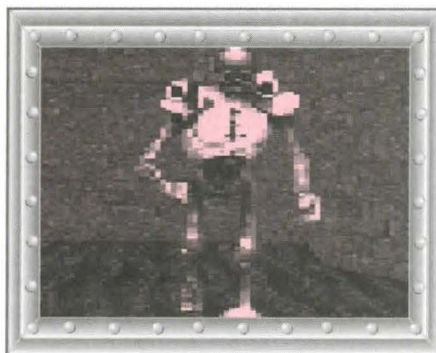
The Mancubus is a grotesquely obese creature with two massive metal guns for arms. Once the Mancubus sights you, he will quickly fire off six rounds, then resight and conduct follow-up attacks as necessary. Unfortunately, they aren't necessary very often.



## Chapter 4 The Bestiary

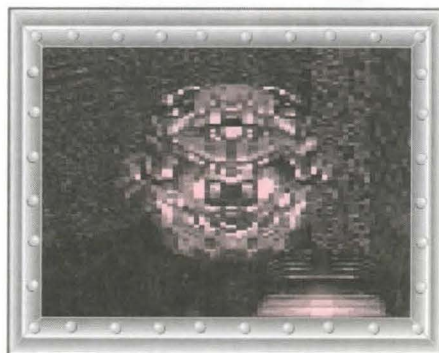
### Revenant

A rocket-launching skeleton with a mean right hook when he is up close and personal. From a distance, he fires slow guided projectiles that are easy to outrun, but always hit on target.



### Pain Elemental

A skull-spitting floating brown ball that resembles a Cacodemon from the original *Doom*. The Pain Elemental actually spits out Lost Souls, which makes it extremely deadly. This is because, even though you are being bombarded with flaming skulls, you must still concentrate some of your effort on killing the Pain Elemental itself, or you'll be fighting forever.



### Arch-Vile

A long-legged, massive attack, raise-baddies-from-the-dead nightmare, the Arch-Vile is probably the hardest demon to defeat. He has a fire attack that is similar to the awesome BFG 9000. If you're in his sight during an attack, you will quickly become Marine flambé. To top it all off, the Arch-Vile runs around the levels raising demons from the dead, undoing all your fine work up to that point.



### **Former Human Commando**

Big brother to the Former Human Sergeants, this ugly post-Marine boasts a large chaingun and can dump heavy amounts of firepower on you in short order. By the way, he is not nearsighted either.

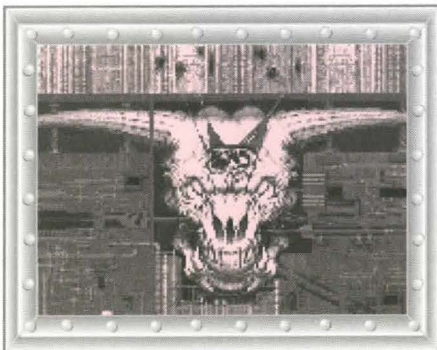
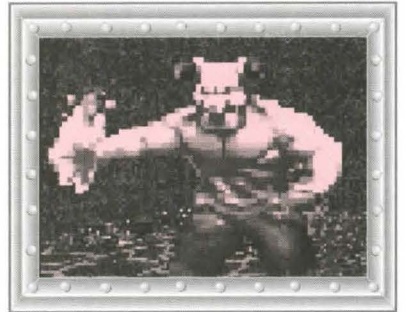


### **Arachnotrons**

The small offspring of the Spider Demon that was the final boss in the original *Doom*. They are nastier offensively, slinging green plasma bolts like pissed off Barons of Hell. But they can't stand the same level of damage as their daddy before going legs up.

### **Hell Knights**

The guardians of the Castles of Hell lay on as much firepower as the Barons of Hell from *Doom*, but also can't take quite as much damage.



### **Final Boss**

It's a huge surprise, and I would hate to spoil it for you Maggot, but if you really can't stand the wait, turn to the intelligence briefing for Mission 30 and you will find the answer.

## Chapter 4 The Bestiary

### TACTICAL RECAP

Whenever you can let the monsters do your dirty work for you, it is always a good idea to do so. Whip them up into a killing frenzy, then go wait it out in some darkened corner and grab a quick sandwich. When you go back to see how things look, you will generally find that the bad-dies have thinned themselves out a bit.

Table 4.1 provides you with a quick reference to the amount of damage each one of these beasts can stand.

**Table 4.1 Hits to kill, by monster and weapon type**

Monster	Pistol	Shotgun	Rocket	Plasma Launcher	BFG
Human	2	1	1	1	1
Sergeant	3	1	1	2	1
Commando	4	—	1	5	1
Imp	6	1	1	3	1
Demon	14	3	1	7	1
Specter	14	3	1	7	1
Lost Soul	10	2	1	5	1
Cacodemon	36	6	2	18	1
Arachnotron	45	7	3	30	1
Mancubus	65	9	4	30	1
Pain Elemental	35	5	2	30	1
Revenant	38	4	2	14	1
Hell Knight	52	9	3	30	1
Baron	100	15	5	50	1
Spider	300	43	15	150	2
Cyberdemon	400	58	20	200	4
Arch-Vile	—	—	—	—	—
Boss	—	—	2	—	—

**DOOM II Hell on Earth**

As you peruse this table, keep this in mind, dipdunks: you gotta hit the target this many times. Every time you throw a wild shot ricocheting off the masonry, not only have you wasted a round of precious ammo that you need to finish the job, but you just might shoot yourself. And trust me on this, you won't get a ticker-tape parade for a self-inflicted wound, sweetcheeks.



## CHAPTER

# 5

## INFANTRY BASICS

OK, dirtbags, now you know your weapons, and you know your enemies—it's time to learn how to put those two things together. I'm talking about ordnance on target, gentlemen. Nothing else matters in the big picture. You've got to get in, kick butt, and get out again. The method you use to do that is known as tactics. We will cover two broad categories of tactics today: fire team tactics and individual tactics.

### FIRE TEAM TACTICS

A fire team is composed of two to four members (note the avoidance of the word "individual") who work collectively to accomplish the mission. A well-trained fire team is poetry in motion. Each member may have his own special areas of expertise but, in the field, the unit moves as one man. Each member knows exactly what to expect from every other member, regardless of the tactical situation encountered, and there is a level of mutual trust and admiration that is unattainable outside the profession of combat arms.

This level of intimacy does not happen overnight. Fire teams must practice every tactic in the book, time and time again, until they can instantly react from even a dead sleep. Then, and only then, are they ready to go into the field. The field, in this case, is the multiplayer cooperative mode of *DOOM II*. For additional details on how to configure network and modem play to become a member of a fire team, see Chapter 7. For more details on how fire teams operate, keep listening.

### **The Fire Team Leader**

For a fire team to remain effective, it must first have a clearly delineated chain of command. Someone has to be in charge to make the command decisions that are required in the heat of combat. This person should *always* be the one with the most combat experience. If a team has trouble deciding who amongst them fits that bill, they need to trade face punches and get that detail squared away before tackling anything else.

Whoever has the next most experience should be appointed second in command. The remaining members of the fire team must be ranked as well. Why is the development of a pecking order so critical? Because people die in combat, dipdunk, and it is usually not a good idea to wait until that moment to figure out who's on deck.

The fire team leader is ultimately responsible for accomplishment of the mission. Concurrent with that responsibility, he can solicit the input of the other team members in the development of a battle plan, but he must be the one who makes the final decision. Other team members are bound by that decision and *must* do their best to support it, whether they agree with it or not. Anyone who fails to understand the need for strict adherence to military protocol in this respect is a danger to the other team members and should be returned to individual duty. You cannot be fully alert and prepared to meet the enemy if one part of your mind is worried about another member of the team cutting and running when the lead starts to fly because he "didn't think it was a good idea to begin with."

In addition to the overall battle plan, the fire team leader controls the following details in the field:

## Chapter 5 Infantry Basics

- Marching order
- Movement formation
- Fields of fire
- Encounter-specific tactics
- Resupply

Let's explore each of these responsibilities in turn, so that you gain an understanding of how they all fit together into the big picture.

### Marching Order

Assuming a four-man fire team, the leader must assign two critical positions: point man and rear guard. For effective control, the fire team leader should not assign himself to either position. Anyone can be given these positions, but good team leaders will generally adhere to the following guidelines on these matters: The point should be taken by whomever among the other team members has the best armor and health at the time. Of the remaining two team members, the most experienced should take rear guard to cover enemies sneaking up behind the team.

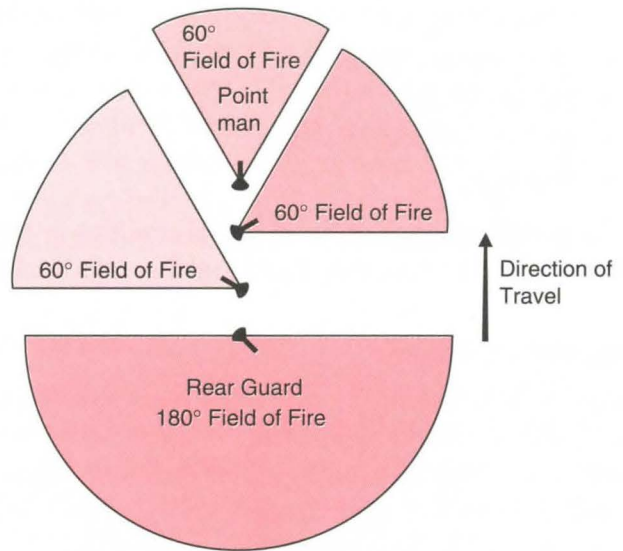
### Movement Formations and Fields of Fire

Rather than having everyone "mill about smartly," an effective squad leader will enforce the appropriate infantry formation for the tactical situation at hand. Five types of movement formations are discussed in the pages that follow. Train your fire team in each of them to the point that they always cover their fields of fire and can effectively maintain formation at any pace, from an easy walk to a dead run.

#### The Column

The most basic of all infantry formations, the column is also one of the weakest. The source of that weakness is that none of the fields of fire overlap. Each member is solely responsible for his field of fire and, if he goes down, the entire team is in jeopardy. This lack of redundancy is intolerable in most situations, but you will find that inexperienced fire teams tend to gravitate toward this formation because it is the easiest to maintain during movement.

## DOOM II Hell on Earth



**Figure 5.1** The column formation allows for rapid movement, but team members cannot support each other's fields of fire without risking hitting one another.

When is a column appropriate? Almost never. Contrary to initial impressions, you definitely would *not* want to send a column down a narrow passageway or corridor. The reason for this is easy to comprehend once it is placed in perspective. Essentially, in a narrow space like that, the only people who would be able to use weapons would be the point man and the rear guard. Further, should the point man come up against something that it would be wiser to run from than fight, he has nowhere to go because the other team members are bunched up on his only escape route.

Instead, send the point man down the passageway alone, while the remaining three team members take up defensive positions outside the entrance to the corridor and cover his back door. If he gets through to the other side without event, he can radio back to the other members. They should repeat the process one at a time until a defensive position is set up at the new location. At that point, the last man comes down the passageway backward.

If the point man runs into any trouble, he can flee backward toward your position, alerting you that something—exactly what, he might not know—is inbound right after him. Be ready. Each member should con-

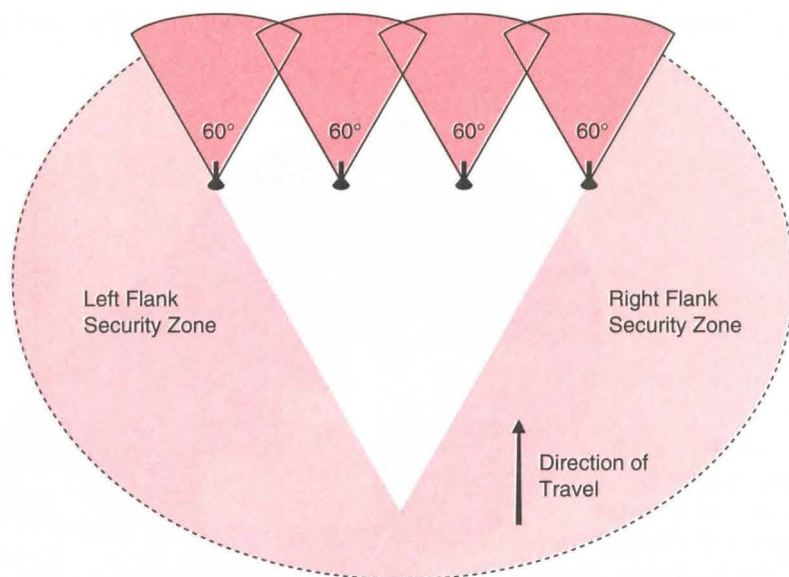
## Chapter 5 Infantry Basics

concentrate his aim on the door but ensure that no other member is potentially in the field of fire. When the point man comes flying out of the door doing the "clinch mountain backstep," kill the next thing that appears and be ready for more.

If the passageway is wide enough for two of you to go down it abreast, form a fighting square. In this formation, the front and rear members are essentially back to back, giving you overlapping fields of fire in both directions, and the entire group goes down the corridor together.

### Line Abreast

Adopt a line abreast formation to cross a large open area. Allow sufficient space between team members to preclude enemy blast weapons from damaging more than one Marine at a time. Concurrently, this forma-



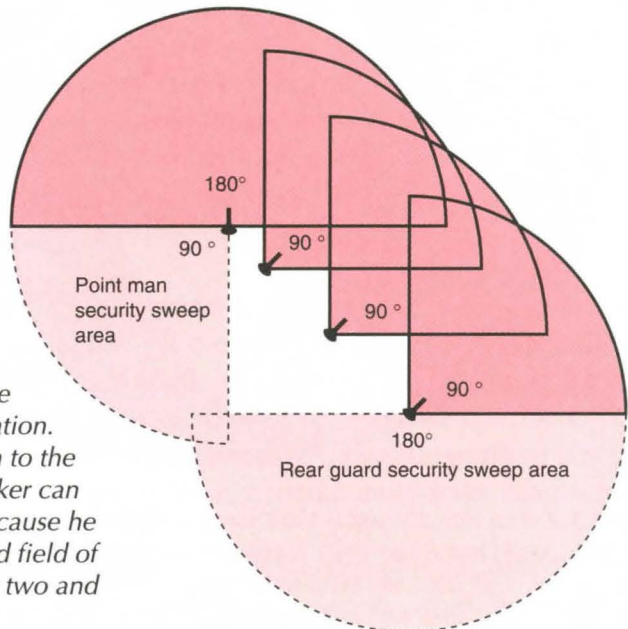
**Figure 5.2** The line abreast is the strongest frontal attack of all the formations, but you should use it sparingly if you are uncertain whether your rear areas are clear or not. The areas encompassed by the dotted lines are security areas. The Marines on the flanks will alternate turning around and walking backward to check their areas of responsibility.

tion allows for maximum frontal firepower and a fair amount of overlap in the fields of fire. Because it also affords maximum protection against friendly fire casualties, it should be used extensively by new fire teams wherever terrain permits.

It is a good idea, however, to train in walking abreast. Go to a cleared area where you can concentrate on practicing the formation and not have to worry about shooting up bad guys. Have one team member go to the overhead map to watch the line progress. On verbal command of the team leader, begin pacing off in rhythmic key presses rather than holding down the  $\uparrow$  key. Count aloud if necessary until all the team members learn the correct pace.

### Echelon Right

It is easy to assume an echelon formation from a line abreast formation. Stop moving for a second. Have the left flanker take six steps forward and stop. The next man takes four steps and stops. The next man takes two



**Figure 5.3** Echelon right is most appropriate when you have reason to believe that the primary threat will come from ahead and to the right of the formation. It also provides slightly better protection to the rear than the line abreast. The right flanker can focus his attentions there more often because he knows that a good portion of his forward field of fire is still being covered by the number two and three men in the formation.

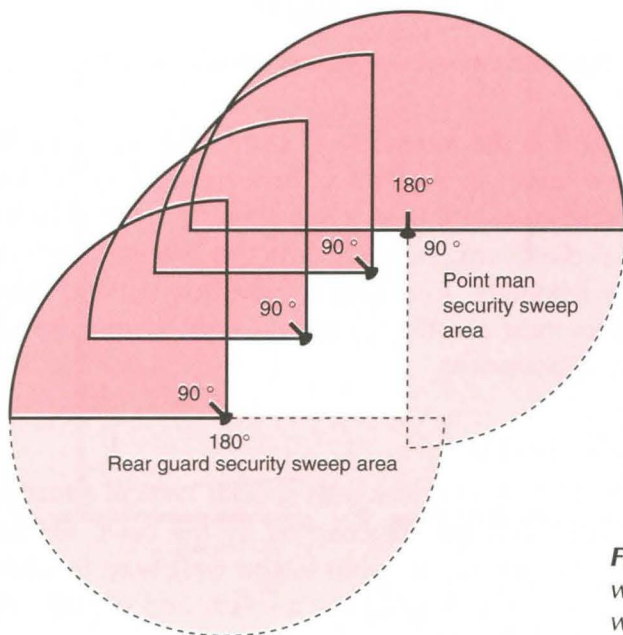
## Chapter 5 Infantry Basics

steps, and the right flanker remains in place. Resume normal movement as you did with a line abreast, and you have quickly created a functioning echelon right formation. Practice this drill a few times and a good team can make the shift in under five seconds and be on the road again.

Echelon right provides the greatest degree of overlap between the fields of fire in the forward right quadrant. As such, the left flank is vulnerable. Therefore, it is not a formation that you want to run around in all the time. Rather, it is one more tactical alternative in your bag of tricks to be exploited when the time is right. For example, if an area is too large to be covered by a line abreast, you could adopt an echelon right, anchoring the point man against the left wall of the chamber, then advance normally. This would provide maximum fields of fire for every member of the team.

### Echelon Left

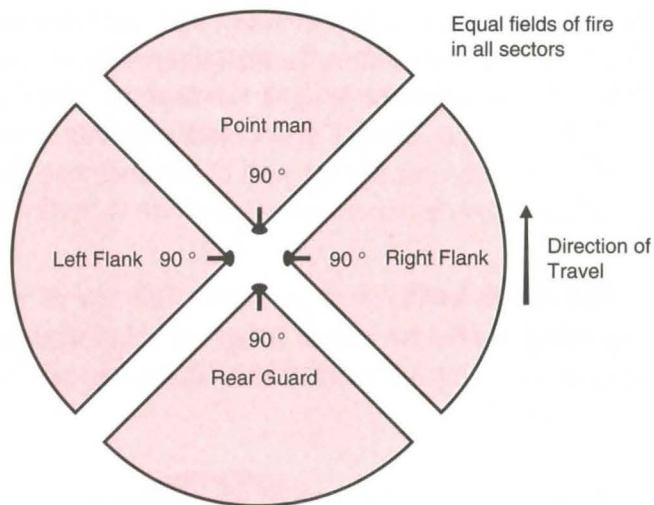
Echelon left is the mirror image of echelon right. Simply reverse the order of stepping out from a line abreast to set up the formation and



**Figure 5.4** Echelon left is best utilized when the threat is expected to appear forward and to the left of the formation.

anchor on the right wall instead of the left when moving through a large open area. All other tactical benefits and limitations of the formation remain the same as those of echelon right.

### Defensive Diamond



**Figure 5.5** *The defensive diamond is an excellent formation for holding your ground against an enemy assault from many quadrants. It can also be used on the move by more experienced fire teams.*

The defensive diamond is the formation of choice for veterans. Not only does everyone have “eyes” in the back of their heads, it is also very easy from this formation to quickly shift to a line abreast frontal assault in any of the four cardinal directions. As such, it is the perfect choice for offensive and defensive flexibility. To maintain formation while moving, the right and left flankers must use the  $\leftarrow$  and  $\rightarrow$  keys, respectively, to sidestep along the path of movement.

### Encounter-Specific Tactics

You need to develop procedures to deal with special tactical situations that occur fairly frequently but are not covered by the basic fire and movement formations. For example, what is the best way to check around corners, enter a door as a group, clear a room, and so forth. Pay attention now, maggots, this information will save your life.



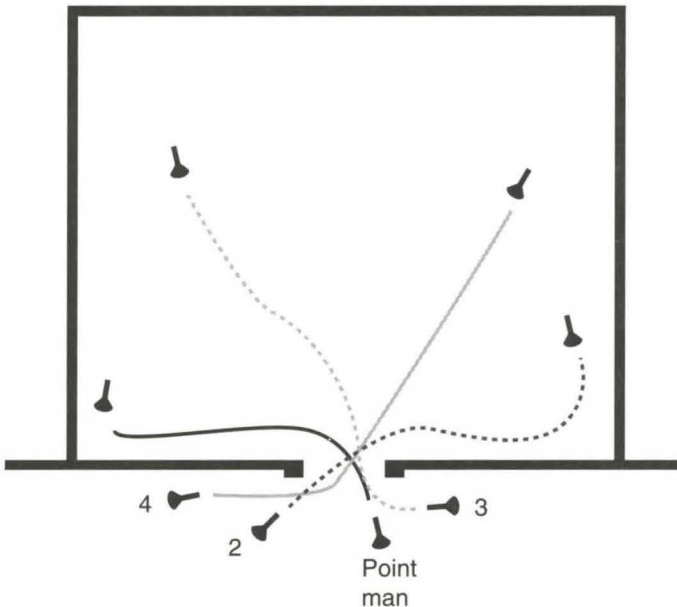
## Chapter 5 Infantry Basics

### Peekaboo, I See You

You will come to a lot of perpendicular branches off the main corridor in *DOOM II*. Regardless of whether you intend to turn down that corridor or pass it by for now, you still have to check and clear it before moving on. The best way to do this is to have the point man slide along the same wall that the branching corridor is on until he is just shy of the corner. Turn and face the wall. Now, hit the  $\leftarrow$  or  $\rightarrow$  key once or twice to "peek" around the corner, then step right back again.

Did you see something you didn't like? If so, you have a few choices. You can repeat the stepping out process, pausing each time long enough to take a potshot at the enemies. You can gather your wits and charge around the corner as a group, guns blazing. You can run past the corridor very fast and continue in the direction you were going, hoping that they didn't notice. Or, finally, you can slink back the way you came and find a nice quiet place to change your skivvies.

### Entering and Clearing a Room



**Figure 5.6** A well-trained fire team has method to their madness. They enter a room with authority and a plan of attack. To do otherwise is foolish.

There is only one, I repeat **ONE**, correct way for a fire team to enter an unsecured door and clear the room behind it. Before the door is ever opened, everybody knows the order of entry and what they are responsible for once they get inside. Those responsibilities generally break down by corners of the room.

For example, consider the team pictured in Figure 5-6. The point man will be the one who opens the door and the first one through. He immediately turns left to clear the “weak side” near corner (because most people are right-handed, the left is generally referred to as the weak side in tactics). That corner is the most likely hiding place for wily opponents. The number two man follows the point man through the door and breaks right to clear the “strong side” near corner. Next, the number three man breaks cover on the right side of the door and sprints diagonally across the room toward the weak side far corner, engaging opponents in the center of the room as he goes. About the time the fourth man is coming through the door, the first two men should have their corners clear and be moving along the outside walls, laying down suppression fire in support of three and four. Man four does just the opposite of the third man, sprinting toward the strong side far corner.

If you consistently practice and follow these entry tactics, not only will you clear rooms more quickly, you will also sustain fewer casualties *and* waste less ammunition (because there is less tendency for more than one team member to concentrate on the same target to the exclusion of others). If you enter a room that contains far more enemies than you expected and a hasty retreat seems in order, simply lay down a covering fire and exit the room in reverse order of your entry, backing up as you go.

### **The FNG Approach**

Once the monsters are agitated, they’ll kill anything, including themselves. The trick is to get them agitated in the first place. Fire teams have a tried-and-true practice for inciting this riot. First, pull the junior man in the squad aside. Calmly explain to him that he is going inside the designated room alone. When he begins to object, point out that he is outnumbered by the rest of you. When he begins to plead that the mis-

## Chapter 5 Infantry Basics

sion you are sending him on is suicide, explain to him that you will let him out of the room again in 30 seconds, but that you intend to kill anything that comes out before that. His job is to run around in circles inside the room, shouting, waving his arms, and thumbing his nose at the inhabitants. Hey, everybody needs a baptism by fire, right?

### More Fun with FNGs

This is a variation on the technique just described. Assemble the team in a well-defended area with lots of cover to hide behind. Set up ambush positions and, when the junior man begins looking for a cozy spot to sit down, inform him that it's his turn to "scout the surrounding area." When he leaves to go start kicking down doors alone, whip out your thermos and grab a sandwich. When you hear a high-pitched wailing sound approaching from the distance, clean up your mess and take a firing position. Don't shoot the first blur that comes through the door, that will be your FNG, but he should have some new playmates in hot pursuit. When the ambush is over, commend the junior guy on what a fine patrol he conducted. Warning: This tactic usually only works once per individual.

### Resupply

As the fire team leader, you are responsible for ensuring that each member of the team has adequate resources to accomplish the mission. Because of this responsibility, you might find yourself in the situation where a dispute over a coveted item must be resolved. Take the military tack. You decide who gets what and don't take any flack from your juniors. If they get out of line once, counsel them. If they do it again, Frag 'em and find someone else to fill the new vacancy on your fire team.

## INDIVIDUAL TACTICS

Although it's always nice to have someone you trust covering your back, the truth is, that luxury is not always available. Sometimes you are just going to have to do it alone, sweet pea, and you had better be prepared

for it. When you go it alone, you do not have the benefit of cover or suppression fire—you must cover the entire 360-degree threat arc yourself.

Here are some tips you can use to better prepare yourself:

- Practice moving with the **[Shift]** key depressed for an extra burst of speed.
- Learn how to strafe. That is a combination of sidestepping and firing at the same time. Only weapons with high rates of fire, like the chaingun and the plasma rifle, are effective for strafing.
- Practice quick changes of direction while you are running at full speed, including a full 180 reversal such that you are running backward.
- Use the early level opponents for target practice. Watch for blood spray to see where you are hitting.
- Use the same corner-clearing methods described in the section on fire team tactics.

The better you are at controlling your individual actions, the more effective you will be as a member of a fire team. As you move into the intelligence briefings that compose the next chapter, remember that it is structured to provide individual players the maximum chance of survival, which often means avoiding many areas on a level altogether. With a fire team, you should have both the firepower and confidence to cleanse each level of the infestation entirely before moving on to the next one. As such, individuals should focus on the optimum route through each level. Fire teams should focus on the monster and item location maps, then take them on in any order they damn well please.

This concludes the formal part of your training. The ball is in your court now. Next, the intelligence spooks will brief you on the specific missions you will face. Listen up to what they have to tell you. You will only hear it once. Let's be careful out there Marines. Good luck and God speed!

## CHAPTER



# INTELLIGENCE BRIEFINGS

## USING THIS CHAPTER

Ok, Devil Dogs, now it's time to hit the bricks and earn that \$100 a month combat pay that Sergeant Workman psyched you up about. This is your intelligence specialist, Sergeant Swann. He will prepare you for the missions better than anyone else could, so listen up!

Good afternoon Marines! Let's dispense with the formalities and get straight to the heart of it. Hell isn't freezing over anytime soon unless we give it some help. Each mission briefing will consist of two elements. First, you will be given an intelligence map that shows the location of all valuable items, as well as the composition and disposition of enemy forces. Overlaid on this map will be a series of red

waypoints marking the location of critical items, such as keys, coded doors, switches, secret rooms, false walls, exits and so forth. These are numbered and indexed sequentially such that you have a quick reference to review in the heat of combat.

The final item you will receive is a level summary report. This detailed document explains the optimum path to complete the level and make it home in one piece. In preparing this document, I have assumed nothing, because we all know what happens when someone assumes. In other words, it is just as if I took you by the nose and pulled you around every corner. Because of that, if you cannot determine the best way to get from point A to point B on the intelligence map, refer to the mission summary report for the straight poop, instead of relying on any scuttlebutt you might have heard around the barracks. That said, let's get on with it . . .

**MISSION 1: ENTRYWAY**

You are standing on a high ledge looking at a triangular staircase and a hallway behind it. There are two Former Humans on the staircase. Take them out, and three more will turn the corner in the passageway and come at you. A few quick pistol shots and they will be history as well. Drop to the room below and clean up your mess. In addition to the ammunition they were carrying, there is a stimpack, armour bonus, and another spare clip in the same room.

Take the corridor to the north. When it turns right, peek around the corner. There will be one Imp to kill, followed by another Human. Halfway down the corridor on the left is a metal door. When you open it, there will be two Imps almost right in your face and four Former Humans on raised platforms in the background. Take your time, place your shots, and clear this room.

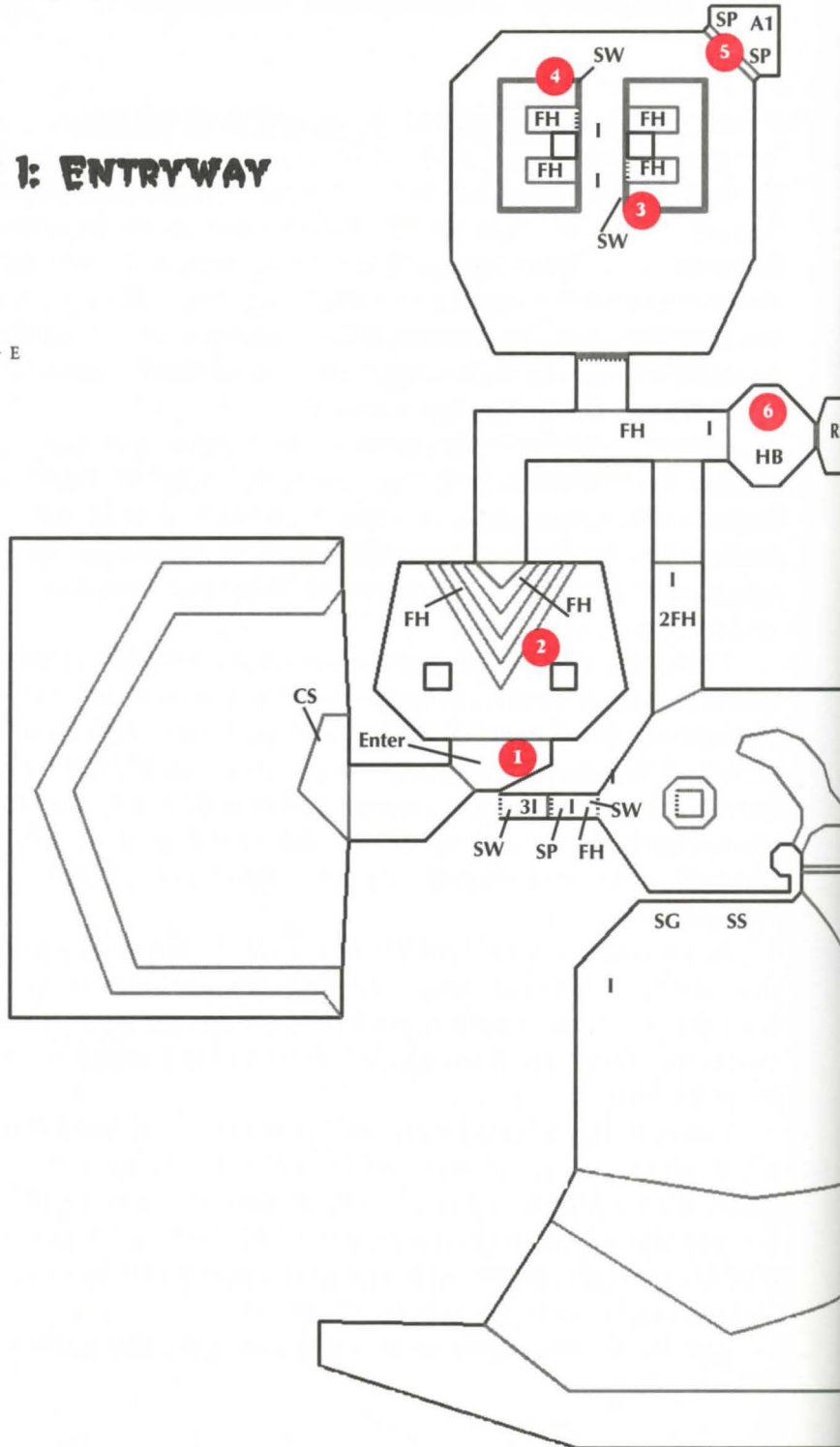
When the room is quiet, go to the narrow opening between the two raised platforms. There will be two switches, on the east and west walls, respectively. Hit the switch on the east wall, then walk to the northeast corner of the room. A triangular secret room should have just opened. Inside, you will find green armour and two stimpacks. Go back to the western switch now and activate it. This lowers all the platforms so you can collect the ammo from the dead Former Humans. Leave the room the way you came in.

At the main corridor, turn left. Go forward a few steps and peek down the corridor that branches to your right. Kill the Imp that comes at you from that direction. Now turn back east and go into the room with all the health bonuses. Suck them up and return to the corridor where you just killed the Imp.

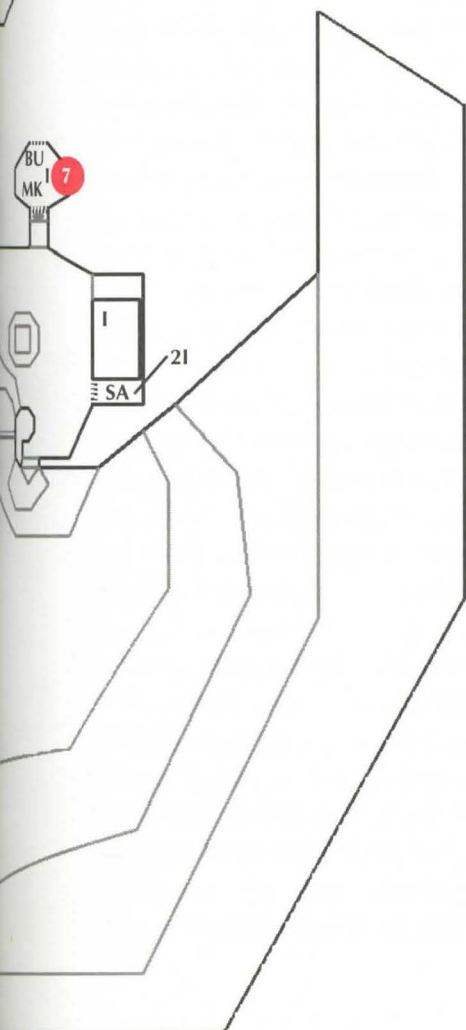
The dark room ahead contains a number of monsters and switches, all of which you are ill-prepared to deal with at this early stage of the game. It's possible to get to a shotgun elsewhere leading off this room, but you will die more often than not in the attempt. Besides, it's easy to pick up a shotgun at the beginning of the next level. As such, your optimum strategy now is just to head for the exit.

Run down the corridor and drop off into the darkened room.

## MISSION 1: ENTRYWAY







### The Bestiary

**FH** Former Human

**I** Imp

### Locations

**SW** switch

### Special Items

**A1** green armour

**HB** health bonus (vials)

**MK** medikit

**SA** spiritual armour

**SP** stimpack

### Weapons & Ammo

**BU** bullets (10)

**CS** chainsaw

**RL** rocket launcher

**SG** shotgun

**SS** shotgun shells (4)

### Waypoints

**1** Start

**2** Stimpack

**3** Switch opens secret room (5)

**4** Switch lowers platforms

**5** Secret room with green armour  
and 2 stimpacks

**6** Health bonuses

**7** Exit

Immediately slide left and follow that wall east to the alcove with the Exit door. Drop into the alcove and turn to face the room you just passed through. This is to clear your back trail of any enemies that may decide to follow you into the alcove. When you are sure you're OK, turn and open the Exit door. Kill the Imp waiting for you there, pick up some needed medical supplies, and throw the switch to get back to reality.

## **MISSION 2: UNDERHALLS**

You start on a raised platform on the northernmost edge of the map. There is a medikit to your right—you don't need it just yet. Shoot the three Former Humans on the platform to the south and run directly across to it as soon as they are dead. Pick up their ammo and go through the door to the south. There will be two Former Humans waiting in ambush there. Kill them and turn left. Don't rush for the stimpack sitting in the corner. Instead, ease forward until you can peek through the columns on your right. Shoot the Former Sergeant lurking there and raise the columns by hitting `[Spacebar]`. Pick up the shotgun and four shells. Flip the switch. This opens the eastern passageway off the entry area.

Go back to the sunken hallway between the two raised platforms and turn right. Don't dawdle in this hallway as there are enemies at your back as well. Work your way down the hallway that curves to your right. You will encounter several Former Sergeants but nothing major. In the first alcove to your right, there is another Sergeant and a medikit. After you pick up the medikit, continue down the hallway until you come to the first left.

This is a short curved hallway leading to a door. Before you open the door, turn back toward the hallway you just came from. One or more Former Sergeants will come looking for you there. Toast them, take a deep breath, and open the door to the south. This is a very crowded room, with eight Former Humans and eight Former Sergeants, but if you can clear them out you will get the super shotgun (in the northeast corner), and there are four stimpacks to heal up as well.

Come back out of that room and reenter the corridor you were in

## Chapter 6 Intelligence Briefings

before. Continue south around the bend. You will see multiple Former Humans and Sergeants on a raised platform with a set of steps leading up to it. Clean them out and grab their ammo ASAP. As soon as you get on the platform with them, you will be sniped at from across a chasm. There is an enclosed room there with several windows through which more Former Marines are sniping at you. The red key is visible on one of the window ledges, but you cannot get it from the north side of the room.

Turn left and follow the raised platform to the east, then south again. As you near the end of the walkway, you will see an opening to the roomful of snipers on the wall across the chasm. Line up with the opening, back up against the east wall, and take a running jump into the room (hold down the **Shift** and **↑** keys simultaneously). There are seven Former Sergeants here, six on your current level and one at the top of the stairs in this room where the red key is located.

Kill them all and take the key. As soon as you do so, two secret rooms open up on the platform/walkway to the north (exactly where you came in on this area of the level). From the two rooms, seven Imps, five Former Humans and one Demon come out. You cannot avoid these guys, but you can snipe at them and help motivate them to kill one another.

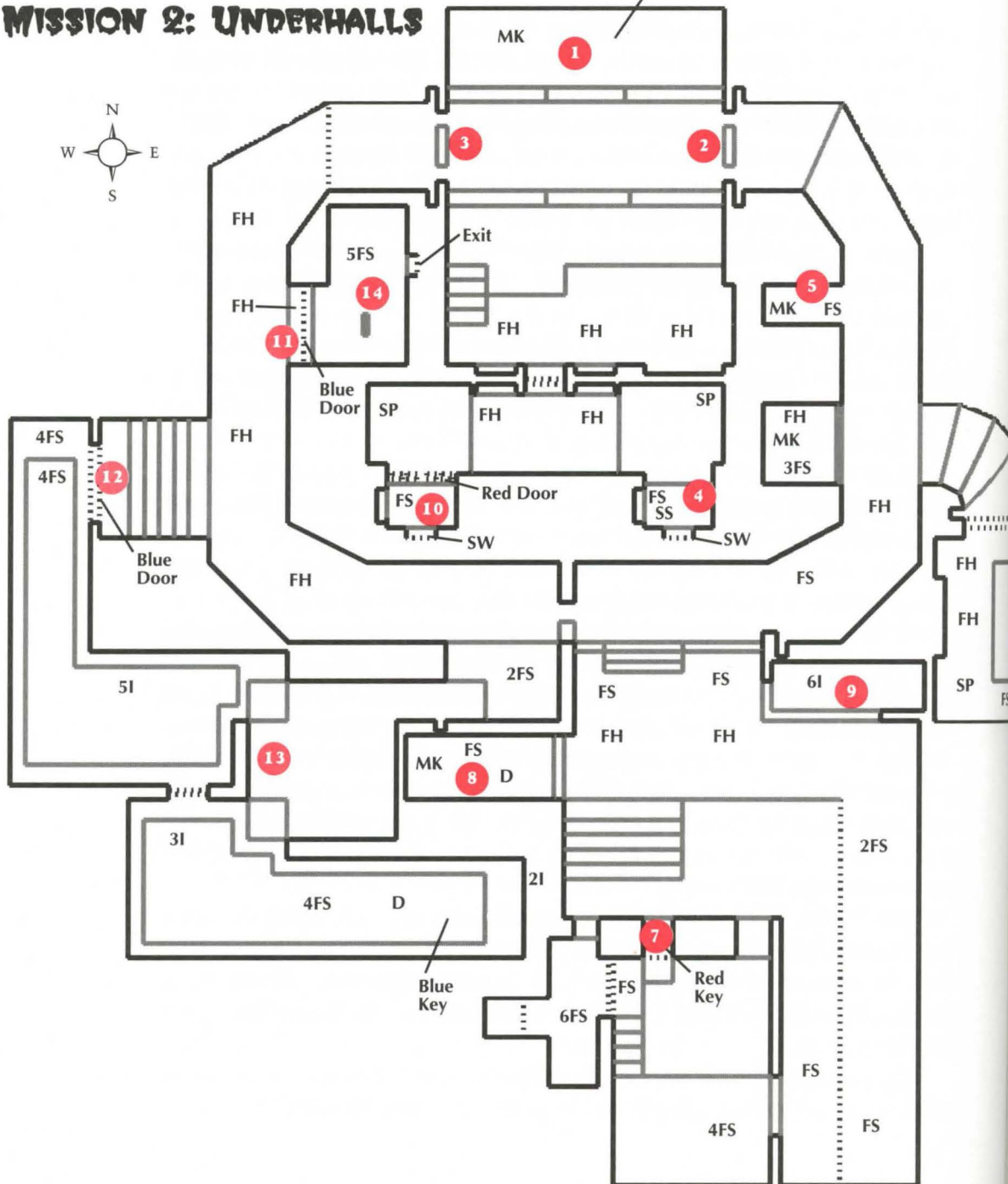
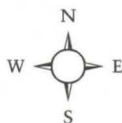
When they are all gone, grab the medikits in the two secret rooms the demons came from and head back to the beginning of the level the way you came. When you get to the first platform to the south, from the level entrance, you will find two new Marines guarding it. Waste them and go through the door to the south again. This time turn right instead of left and proceed to the second set of columns. Snipe between the bars to get the Sergeant behind them, then use the red key to open the door. Throw the switch inside this room, and you will open the western door of the sunken corridor.

Head back north to the sunken corridor and turn left. There will also be a curved passageway around to the south. You will encounter minor Human opposition in this corridor and pass two blue doors (the first on the left, the second down a flight of stairs to the right). Ignore them and continue onward.

Go into the next alcove on your right (to the south) and continue to the southwest corner of the room. You will have to kill some more

# MISSION 2: UNDERHALLS

Enter



**The Bestiary**

- D** Demon  
**FH** Former Human  
**FS** Former Human Sergeant  
**I** Imp

**Locations**

- SW** switch

**Special Items**

- MK** medikit  
**SP** stimpack

**Weapons & Ammo**

- DS** combat shotgun  
 (super shotgun)  
**SG** shotgun  
**SS** shotgun shells (4)

**Waypoints**

- 1** Start
- 2** Barricade
- 3** Barricade
- 4** Switch lowers (2)
- 5** Sergeant and medikit
- 6** Super shotgun
- 7** Red Key
- 8** Secret door triggered by (7)/  
Demons, Sergeants, medikit
- 9** Secret door triggered by  
(7)/Imps, medikit
- 10** Switch lowers (3) in room with  
Red Door
- 11** Blue Door
- 12** Blue Door
- 13** Go through left hole in the floor  
to get Blue Key
- 14** Go back through Blue Doors  
and exit here



Former Humans on the way. As you pass through into the next room (which is lightly defended by two Former Sergeants and a Former Human), be aware that there are descending platforms straight ahead of you in the northeast corner and southeast corner. Turn left and hug the wall to go through the one on the south.

You are now in the room with the blue key, but it is very dark and very dangerous. There are five Imps, one Demon and four Former Sergeants here, but there are also barrels of toxic waste in every corner. Shoot the barrels with your shotgun to maximize the damage they will inflict on the unsuspecting monsters. You will have to go around a corner and back to the east to get to the platform with the blue key.

Once you have the blue key, turn back west, then north. You will find that you cannot go back out the door you just came in, but there is another door in front of you to the north. Go through it and grit your teeth, you are almost home free.

The room you just entered has five Imps and four Former Sergeants. Incite a riot and let them work on each other. Turn left, then right to head north to the opposite side of one of the blue doors you saw previously. Use your new key to open the door and go up the stairs outside it. Turn left and go to the other blue door. Use your key to open this, but be ready for action. There are five Former Sergeants and one Former Human on the other side, but this is also the Exit room. If you have the stamina and ammo to get past them, throw the switch inside this room and you are out of there!

### **MISSION 3: THE GANTLET**

This is a tough level, but it can be beaten! Remember the basics of fire and movement, then follow these instructions to the letter. You begin at the western end of the map in a small room with an alcove to the north and a door to the east. Peek around the corner into the alcove and kill the Former Human (if he is there, sometimes he is not). Open the eastern door and step out onto the ledge overlooking the courtyard. Grab the shotgun quickly and back up into the room you just left before the door closes again.

## Chapter 6 Intelligence Briefings

You will be taking heavy fire from the courtyard before the door closes, so continue all the way back to the corner of the room. In the courtyard there are five Former Humans, one Former Sergeant, and four Imps. Repeat the procedure of going out on the ledge, popping off a quick shot to stir them up, and backing into the room again. If you do this a couple of times, their numbers will be reduced a bit before you go out to fight for real.



Some players have trouble understanding why this tactic works some of the time, but not always. The reason has to do with the mix of monsters that inhabit the same room. Since the tactic can be used a couple of times on this level, the monster damage effects are explained here. Not all of the monsters discussed in the next three paragraphs are in this level, but you can use this information to your advantage throughout the game as well, not just in this level.

Monsters of the same type are immune to the special ranged attacks of their brethren. For example, Imp fireballs do not harm other Imps, but they are damaging to all other monsters (likewise with the Baron of Hell plasma attacks, Cacodemon lightning balls, and Cyberdemon rocket attacks).

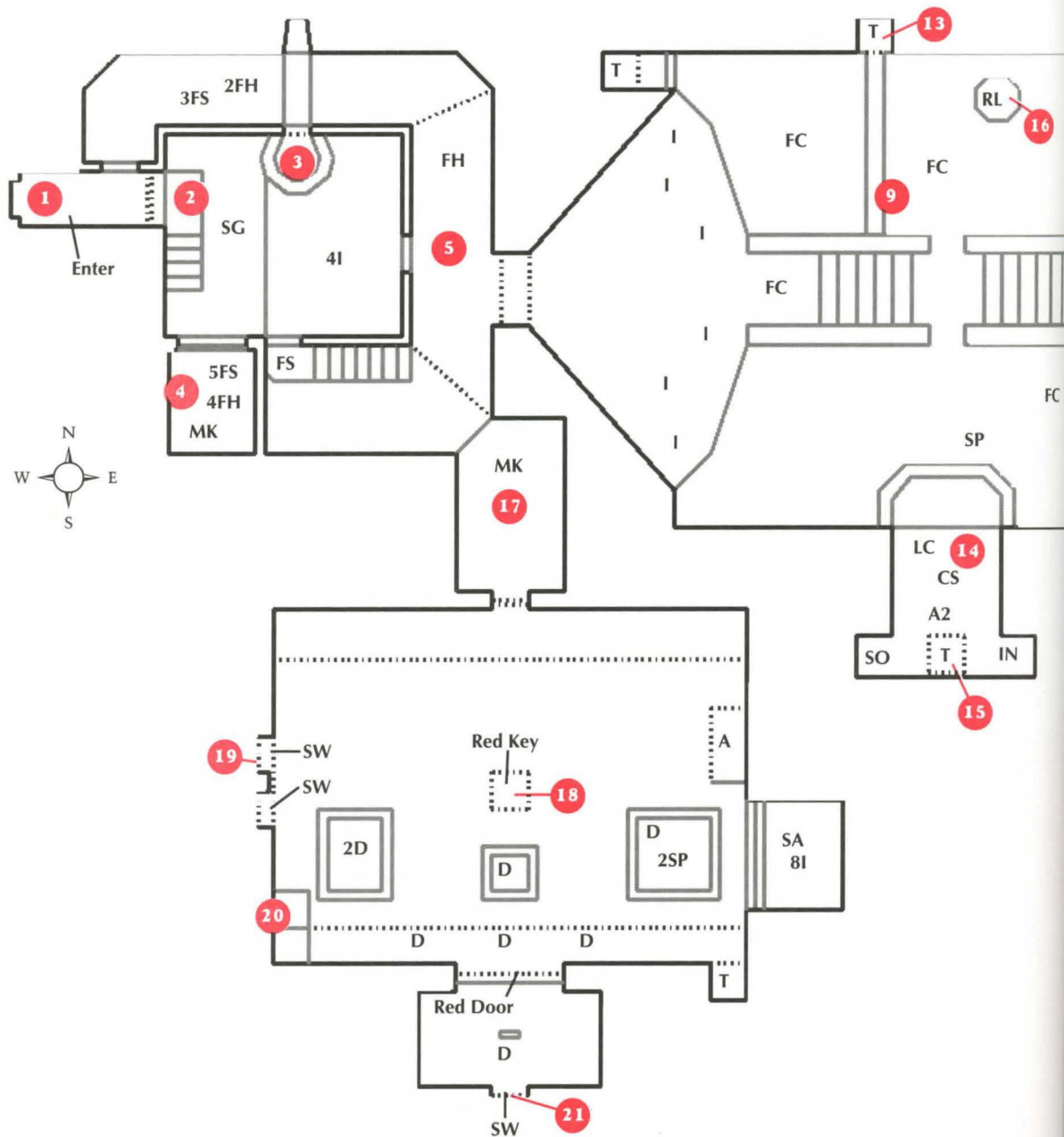
Bullet attacks are fair game for all enemies. As such, stirring up a Former Commando or two in a heavily populated room can thin the remainder of the population quickly. Just keep moving so you spread their fire around and prevent them from drawing a bead on you.

Clawing and biting attacks are difficult to misdirect, but it can happen in close quarters. When it does, Demons, Spectres, and Lost Souls will all go after one another until there is only one left standing. With all these conditions in mind, let's return to the discussion of this level.

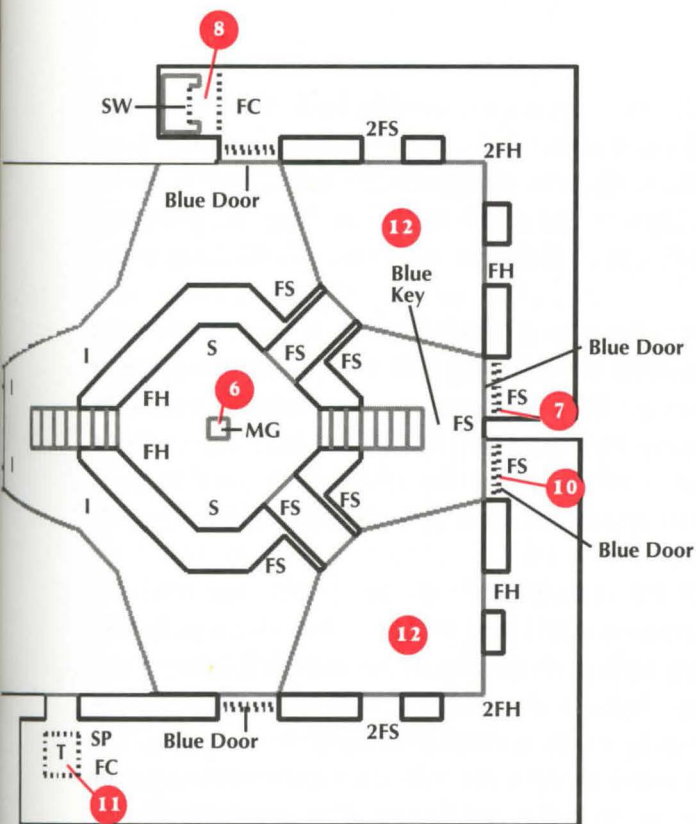


When you are ready to fight, go through the door for the last time and drop off the platform to the yard. While facing southeast and laying down

## MISSION 3: THE GANTLET







## Waypoints

- 1 Start
- 2 Shotgun
- 3 Blue armour
- 4 Secret door opens when you grab (3), releasing Former Humans
- 5 Platform with medikit
- 6 Chaingun and Blue Key
- 7 Blue Door
- 8 Switch raises (9)
- 9 Hidden platform
- 10 Blue Door
- 11 Transporter
- 12 Medikit and bullets
- 13 Transporter
- 14 Large cell, blue armour, invisibility, soul sphere
- 15 Transporter
- 16 Transporter (15) takes you here
- 17 Transporter (13) takes you here
- 18 Red Key
- 19 Switch lowers (20)
- 20 Lift platform
- 21 Exit

## The Bestiary

- D** Demon  
**FH** Former Human  
**FC** Former Human Commando  
**FS** Former Human Sergeant  
**I** Imp  
**S** Spectre

## Locations

- SW** switch  
**T** transporter

## Special Items

- A2** blue armour

**IN** invisibility sphere

**LC** large energy cell

**MK** medikit

**SO** soul sphere

**SA** spiritual armour

**SP** stimpack

## Weapons & Ammo

**A** box of ammo

**CS** chainsaw

**MG** machine gun (chain gun)

**RL** rocket launcher

**SG** shotgun

fire at any remaining survivors in the room, quickly back into the north-west corner to pick up a box of shotgun shells. Once you have the box, head directly for the recessed stairway in the south wall. Don't dawdle, because there are snipers high on the north wall. Don't try to fight them from the courtyard—you'll get to them in a minute. Continue up the stairs.

At the top of the stairs, there is a platform to your right with two medikits visible. This is actually the opening that leads to the final room in the level, but you cannot get there yet, nor can you grab the medikits. Turn left at the top of the stairs and clear any opposition from the corridor to the north. There is a platform with another medikit on your right. It lowers automatically as you approach. Don't take this ride just yet—you have more work to do first.

Continue to the end of the corridor and turn left again. You are now pointed back to the west and must kill four more Former Humans in this corridor, two of whom are hiding in an alcove to your left (where the blue stream crosses the hallway that overlooks the courtyard). When these are dispatched, you will pick up a set of blue armour.

When you grab the armour, a secret door in the southwest corner of the courtyard opens, allowing several more Former Humans to pour out. Drop off the ledge and waste them, then go into the room they came out of. Pick up the medikit and go back upstairs to the platform that lowered automatically before. It will do so again. Step on, grab the medikit there (you should be in fairly decent shape now), take a deep breath, and get ready to run (hold down the **Shift** key).

When the platform rises, everybody and their brother will be shooting at you. **DO NOT ATTEMPT TO HOLD YOUR GROUND AND RETURN FIRE!** Instead, run due east as far and as fast as you can. The only time you should shoot during this process is if something blocks your direct path. You will go down, then up two sets of staircases, picking up a chain-gun on the way. At the top of the second staircase is the blue key and two blue doors. Immediately go in the door on the left, but don't stop to catch your breath just yet. There are five Former Humans in this L-shaped corridor, including one commando. Kill them all as you proceed north, then west around the corner of the L. Run to the switch on the western end and

## Chapter 6 Intelligence Briefings

trip it. This raises a narrow bridge from the northern wall of the first staircase in the room to a teleport high on the outside north wall.

While you were making this mad dash, bullets were flying everywhere in the central area that you just ran through. At least some of the opposition out there will be dead, but there will be plenty left. You will notice that the room you are in has a number of windows overlooking the central area. Ease up to the edge of these windows and peek in all directions. Look for any signs of life in the area below and trash them. You're the sniper now, Marine. Use each window in this room in this manner and you should clear a good portion of the northern side of the area.

Come back out the blue door you entered, turn left immediately, and go in the blue door next to it. This is almost a mirror image of the L-shaped room you just left, with the same level of opposition, but at the end there is a medikit and a teleport. Don't go into this teleport. Use all the windows in this room as sniper vantage points as well and you will have cleared out much of the southern side of the main area.

When the area appears secure, drop to the water below out of the window next to the inside junction of the L-shaped room. There is a medikit and a box of bullets here. Wade toward the tunnel to the northwest. At the end of that tunnel is a central water pit (where you breezed through and grabbed the chaingun earlier in the level). There should be a number of dead bodies here, but two live Spectres as well. Sweep the room with the chaingun until you see blood splatter, then stay on it until the bullets begin to hit the wall behind. With that one down, find the second one by repeating the process.

Collect all the weapons and ammo in the water pit, then go out the tunnel to the northeast. Pick up another medikit and box of bullets there. Go back into the pit the same way and start up the stairs to the west. As you get to the top, you may see some Imp fireballs approaching from the far western platform. Return fire and back down the stairs quickly so they don't hit you. Repeat this tactic until all the Imps are dead.

Go back to the west across all the stairs you came over on the way into the area. When you get to the western platform, turn around and walk out the top of the north wall that borders the stairs. The walkway

you raised earlier with the switch branches off to the north near the end. Turn onto this walkway and go all the way to the north, without entering the teleport that is in a recessed alcove just yet. Turn around to face south and line yourself up along the ledge. Hold down the **[Shift]** key and run forward as fast as you can. You will jump across the stairs, hit the narrow ledge on the other side, then jump again to a small circular ledge on the other side of the toxic pit.

Grunting as you hit the wall with all that momentum, you turn left and drop into a water-filled pit. Here you will find a bulk energy cell, blue armour, a soul sphere, and a globe of partial invisibility. Pick them up in that order, then enter the teleport in the room. You are now on a circular platform in the middle of the northern toxic pit. Face south, then jump off and swim to the stairs in front of you. Turn right and go up the western set of stairs. Return to the narrow walkway with the teleport on the north wall. This time, go into the teleport.

You will be in the room that leads to the final area in the level. Pick up the two medikits you couldn't reach before and rush to the door on the south wall. You should still be enjoying the benefit of your partial invisibility if you've been moving fast. When you go through the door, you will be on a high ledge. Jump off to the rectangular room below. Grab the red skull key from the central platform. There will now be four Demons and two Spectres in the room with you. If you're feeling studly, waste them. If you're low on ammo (which you should not be), use the remaining invisibility time to get out of Dodge.

To get out of the room, go to the west wall. There are two switches there. The one on the right briefly lowers a platform in the southwest corner of the room. This is where you want to go to get out. Leave the switch on the left alone. It opens a secret room on the east end of the area you are in, releasing eight Imps (there are also seven armour bonuses in the room, but it is a poor trade-off for having to fight them).

After you throw the right switch, ride the platform to the top. Turn left. Go halfway down the ledge to a door on your right. This is the exit room. Open the door, kill the Demon waiting behind it, and throw the switch to say good-bye to this demonic level forever.

## Chapter 6 Intelligence Briefings

### MISSION 4: THE FOCUS

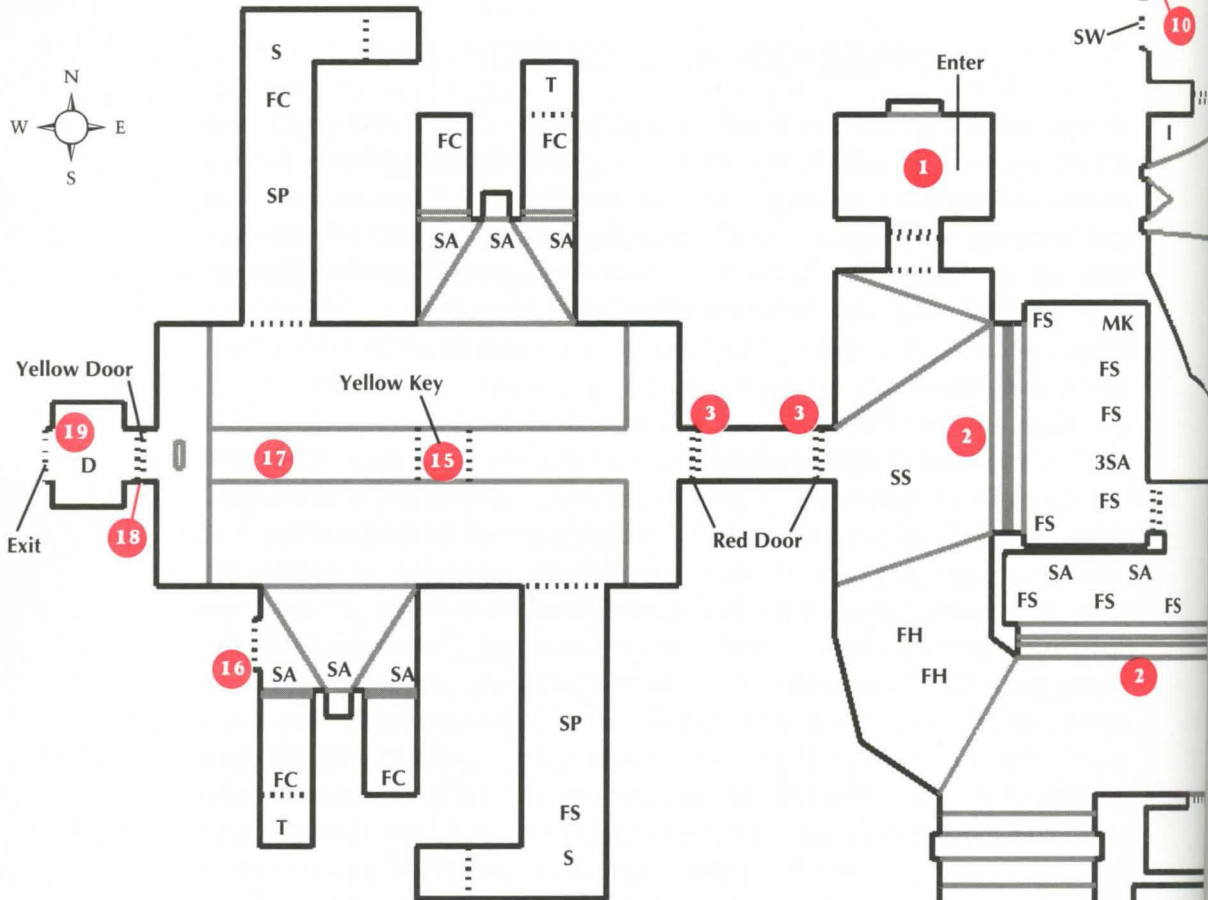
As you enter, you are in a small room. Open the door in the south wall where you will see two Former Humans in the hall running south. From a room beyond them, you will see two Sergeants and two commandos coming your way. Move in and out of the doorway, firing at them until they are all dead. You will also see a long window in the east wall of the hall with five Sergeants behind it shooting at you. There will be a steel shutter opening and closing. Use the same procedure on them. Proceed down the hall.

Across from the window in the west wall is a red door. At the end of the hall is another hall going east and a set of stairs climbing to the south. Turn the corner to the east and in the north wall will be another window with a shutter like the first, with five more Sergeants behind it. After you wipe them out, go up the stairs. Be careful, the south and east walls are made of grating and there are bad guys behind them. There are also two Former Humans in the northwest corner whom you must kill. Grab the shotgun shells in the middle of the room and hit the switch in the southeast corner. Now go back down the stairs and follow the hall to the east.

At the end of the north wall on the left of the light is a secret door leading to the rooms behind the shutters—go in and grab the booty. Go back and through the door at the end. You will see a blue door on your left and a hall going south on your right. Follow the hall south—if you did a good job from the room with the grate walls, everything here should be dead except for one Spectre. He will be in a pool of toxic waste on the right of the hall. He can't get out, so ignore him. Follow the hall to the end where you will find seven helmets and the blue key—the switch you hit earlier lowered the platform the key is on.

Follow the hall back toward the blue door. When you get to the pool the Spectre is in, be careful. A panel will have opened in the south wall with three Imps and two stimpacks behind it. Continue to the blue door. When you open it you will be facing north into a hallway that curves to the west. In the hall are three Imps and a commando. Using the doorway for cover, mow them down. Through a window in the hall, you can see

# MISSION 4: THE FOCUS



### The Bestiary

- D** Demon
- FH** Former Human
- FC** Former Human Commando
- FS** Former Human Sergeant
- I** Imp
- S** Spectre

### Locations

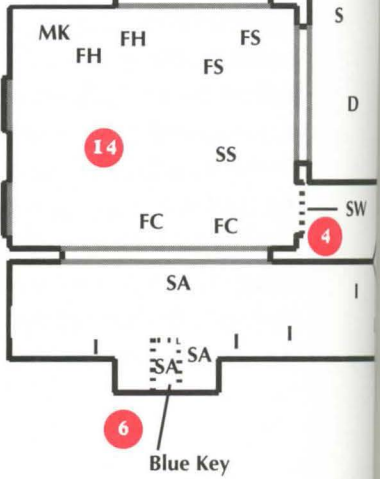
- SW** switch
- T** transporter

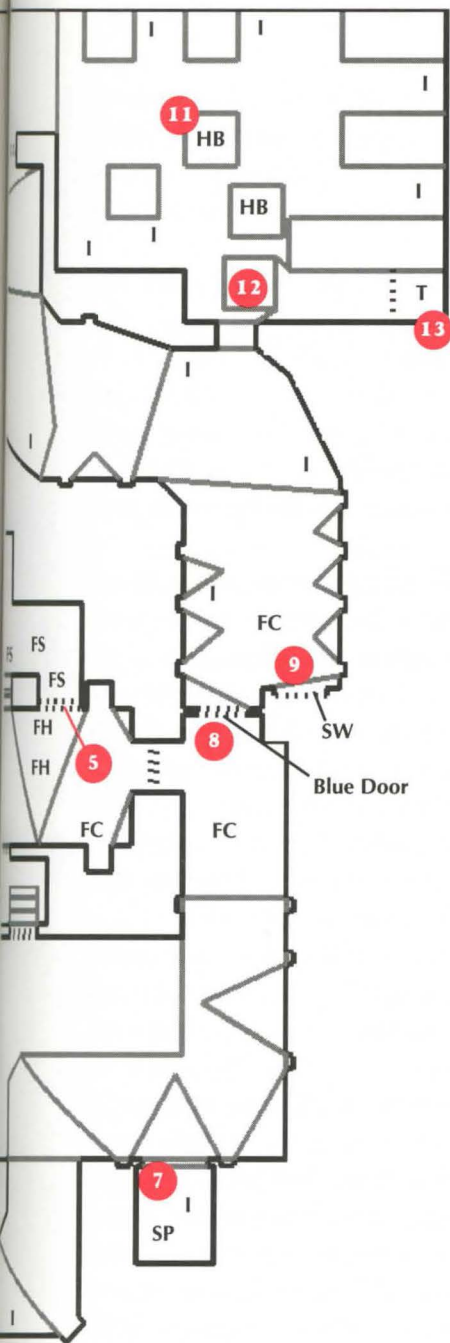
### Special Items

- HB** health bonus (vials)
- MK** medikit
- SA** spiritual armour
- SP** stimpack

### Weapons & Ammo

- SS** shotgun shells (4)





## Waypoints

- 1 Start
- 2 Window with opening and closing shutter
- 3 Red Door
- 4 Switch lowers platform with (6) on it
- 5 Secret door leading to room behind shutters
- 6 Blue Key
- 7 Secret door to room with 3 Imps, 2 stimpaks
- 8 Blue Door
- 9 Light switch
- 10 Box, when stepped on lowers (11)
- 11 Box, lowered by (10)
- 12 Red key
- 13 Transporter
- 14 Where (13) takes you
- 15 Yellow Key
- 16 Switch which raises (17)
- 17 Secret platform
- 18 Yellow Door
- 19 Exit

the red key. The hall is dark, but there is a light switch on the east side of the door. Follow the hall to the end, where you will encounter two more Imps just before you reach the door—kill them and open it. In front of you will be three health bonus vials sitting around a small box, and a switch in the west wall.

There is a small chamber off the room to the east. In the room are several boxes, and on top of two of them you can see health vials. Hidden among the boxes are six Imps, so move through and clear them out. Go back to the box by the switch and stand on it. You will notice one of the crates with the health vials on it lower to the floor, so get on it and ride up. Two crates away to the south is the red key. Grab it, and pick up the health vials on the way. Jump off the crate on the east side and enter the transporter.

You will find yourself back in the room with the grate walls. Go down the stairs and follow the hall north till you get to the red door in the west wall. Open it and you will see another red door to open. You will be in the center of a platform one story above the floor running north/south. Extending west from this is a walkway into the center of the room, with the yellow key at the end, and across from this is the currently inaccessible yellow door. You will see two doorways on the level below, one in the south end of the east wall and one in the west end of the north wall. On your level are two alcoves, one in the east end of the north wall and the other in the west end of the south wall. Ignore the key for now.

Drop off the platform into the northeast corner of the room and move to the opening in the west end of the north wall. Kill the commando and the Spectre inside without breaking the plane of the doorway. Once they are dead, run in and grab the three stimpacks in the hall. Turn around and go back to the opening. You will see that two doors have opened in the alcove in the south wall, releasing two commandos—the same thing has happened in the alcove in the north wall. Kill the first two commandos, move out into the room, and turn and kill the commandos in the north alcove. Now move to the opening in the southeast corner. Kill the Sergeant and the Spectre in this hall. Go down the hall, picking up the three stimpacks as you go, and enter the transporter at the end of the hall. This will deposit you in the alcove in the south wall. Hit the switch in the west wall, pick up the miniguns, and enter the transporter. You will see



## Chapter 6 Intelligence Briefings

through the opening on the west side of the south wall—hitting the switch extends the platform that the key is on all the way to the door. You will be deposited in the same place you were when you entered. Get the key, open the door, blast the Demon behind it, and hit the switch to exit.

### MISSION 5: THE WASTE TUNNELS

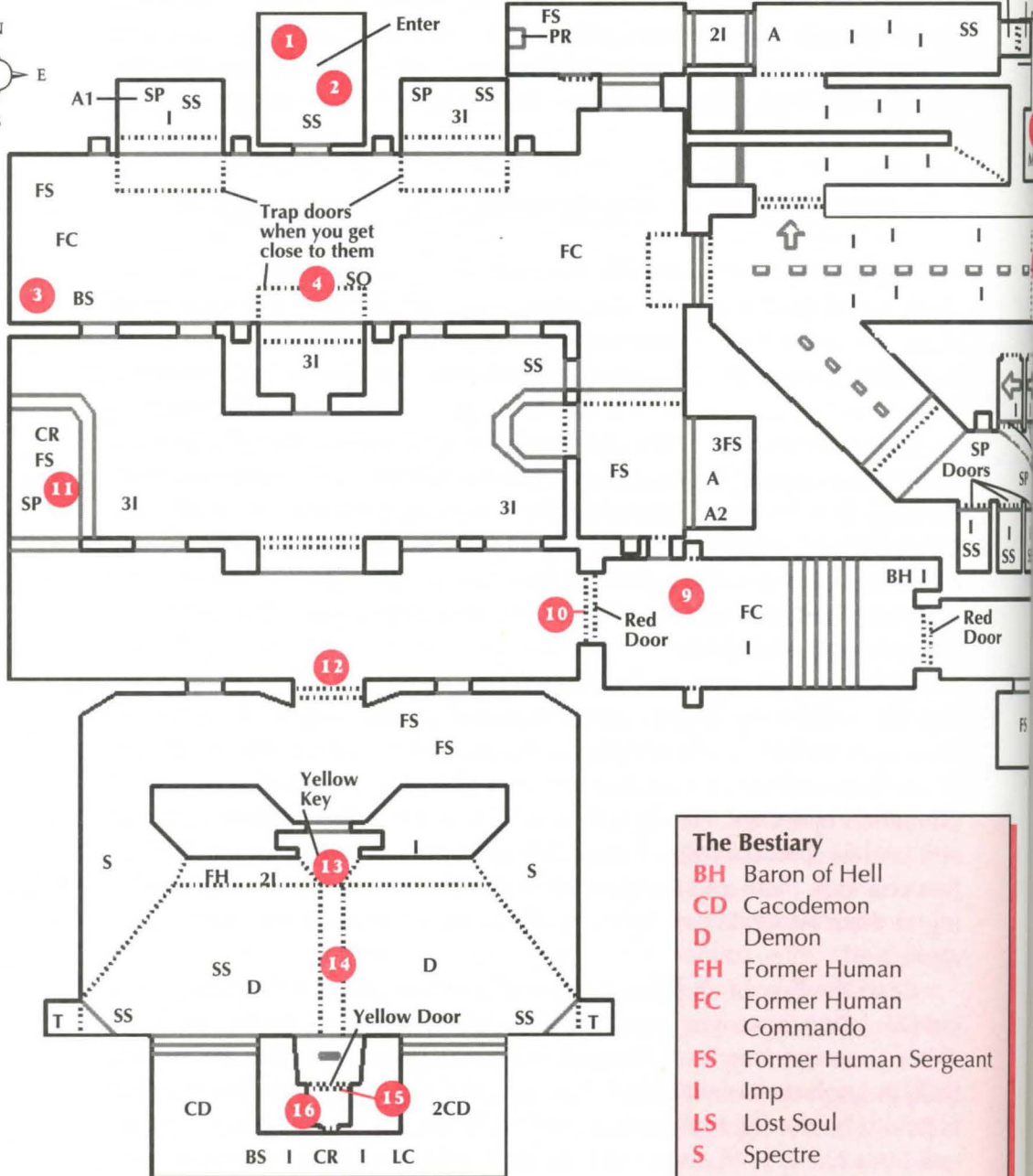
You begin in a small room with the super shotgun directly in front of you. Grab it and go through the door. You are in a hallway that runs east to west. There are two Former Sergeants and two commandos in the same hall. Back up into the doorway you just came through and let them come to you. As they cross in front of the doorway, send them back to hell.

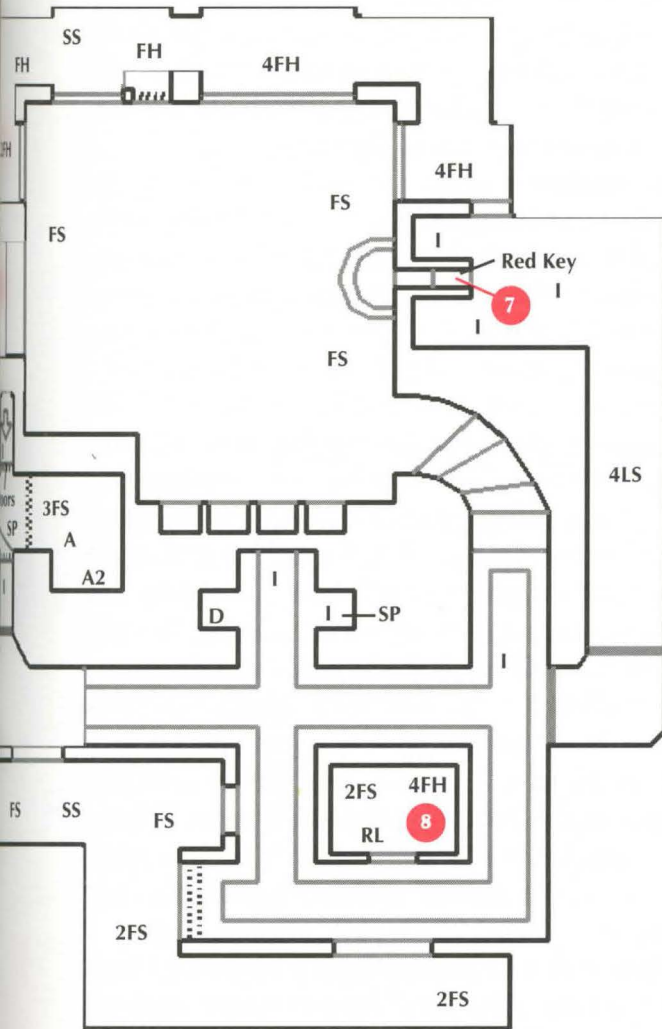
Step back into the hall and turn west to grab the shotgun shells. Turn back to the east and haul butt for the doorway. Pick up the soul sphere on the way. Stay in the middle of the hall, as there are traps on either side. The hall splits, straight and to the right. There are six Imps directly ahead. Kill them. At the east end of the hall is a raised platform where three Sergeants and two commandos will be shooting at you. Kill them and advance on the platform.

When you get there, a section will lower. Hop on and ride it to the top. You will be entering a new room from the west wall. Inside the room there are four barred openings and two doors, one in the southeast corner of the east wall and one in the center of the north wall between two of the barred openings. The other two openings are in the north ends of the east and west walls, respectively. The openings allow you to see the hall that connects them and it is jam-packed with Former Humans. Start sniping at them ASAP. When they are all down, go through the door in the north wall.

Grab the box of shotgun shells and turn left. Around the corner is a medikit. Grab it, retrace your steps, and go to the other end of the hall. There is an opening here, through which you can see water. Poke your head through the hole and withdraw quickly. This will attract the Imp that is lurking to the right of the hole. When he shows his ugly mug, redecorate it for him. Go through the hole. The red key is in the second alcove to your right. Paste the Imp in the third alcove while you're at it.

## MISSION 5: THE WASTE TUNNELS





### Waypoints

- 1 Start
- 2 Super shotgun
- 3 Box of shells
- 4 Soul sphere
- 5 Lift platform
- 6 Medikit
- 7 Red Key
- 8 Rocket launcher
- 9 Blue Key
- 10 Red Door
- 11 Stimpak, case of rockets
- 12 Blue Door
- 13 Yellow Key
- 14 Secret platform that raises when you get (13)
- 15 Yellow Door
- 16 Exit

### Locations

**T** transporter

### Special Items

**A1** green armour

**A2** blue armour

**B** berserker pack

**IN** invisibility sphere

**LC** large energy cell

**MK** medikit

**SO** soul sphere

**SP** stimpack

### Weapons & Ammo

**A** box of ammo

**BS** box of shells

**CR** case of rockets

**PR** plasma rifle

**RL** rocket launcher

**SS** shotgun shells (4)

Turn left (east) and follow the hall until it turns to the south. There are six Lost Souls floating there. Give them peace and continue to the south. At the end of the hall there is an eight-foot drop to a small chamber with a hall running out of it toward the west. There is another hall running north to south creating a T at the opening of this chamber.

When you exit this chamber, there will be a short drop and two Imps waiting for you at the end of it, one to the north, the other to the south. Waste them and follow the hall south. It quickly turns west, where you will see the opening to a room on the north wall and a barred window across from it on the south wall. Kill the guys on the other side of the bars and everyone in the room. Enter the room and grab the rocket launcher.

Exit the room and go west. Turn right at the first hall to the north. Kill the Imp ahead of you, then peer out the window he was standing near. From this vantage point, you ought to be able to snipe away and clear out some of the enemies below, thereby making your task later on a bit easier.

Continue north and turn west at the first hall. Go to the end of the hall and open the door. On the other side there will be a commando and an Imp at the top of a flight of stairs. Go in with guns blazing to make short work of them. The blue key will be at the top of the stairs where they were standing, as will a red door in the west wall. (Note: Watch out for sniper fire from the window in the north wall.)

Go through the red door and you will be in a long hallway with four commandos and a blue door in the middle of the south wall. Kill the commandos and move to the west end of the hall, where it corners to the north. You will find a stimpack and a case of rockets there. Grab these and go back to the blue door.

When you get on the other side, you will be in an east/west hallway that curves to the south at either end. There will be a Sergeant on either side when you first step into the hall. Kill both of them and head west around the bend to the south. Be alert for the Spectre waiting for you there and trash it. Here, the hall overlooks a pit with water in it. The opposite wall has three openings, two large and one small. To the left, there is a catwalk with five Imps that must be cleared.

As soon as the Imps are dead, you will see the yellow key beside the bodies. Walk down the catwalk, grab the key, and turn to face the three openings just mentioned. By grabbing the key, you set off a trap that

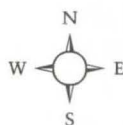
## Chapter 6 Intelligence Briefings

causes these openings to release three Cacodemons, one from the door on the right and two from the larger openings on your left. At the same time, it also raises a narrow catwalk across to the smaller opening, which you can now see is a yellow-keyed Exit door. Don't wait for the catwalk to come all the way up before you start to move, as this will expose you to fire from the three Cacodemons for too long. Instead, as soon as you see the catwalk begin to come out of the water, jump to it and begin running for the door. By the time you get to the end of the catwalk, it should be fully elevated. Jump through the door and slam that switch home to get out of Dodge.

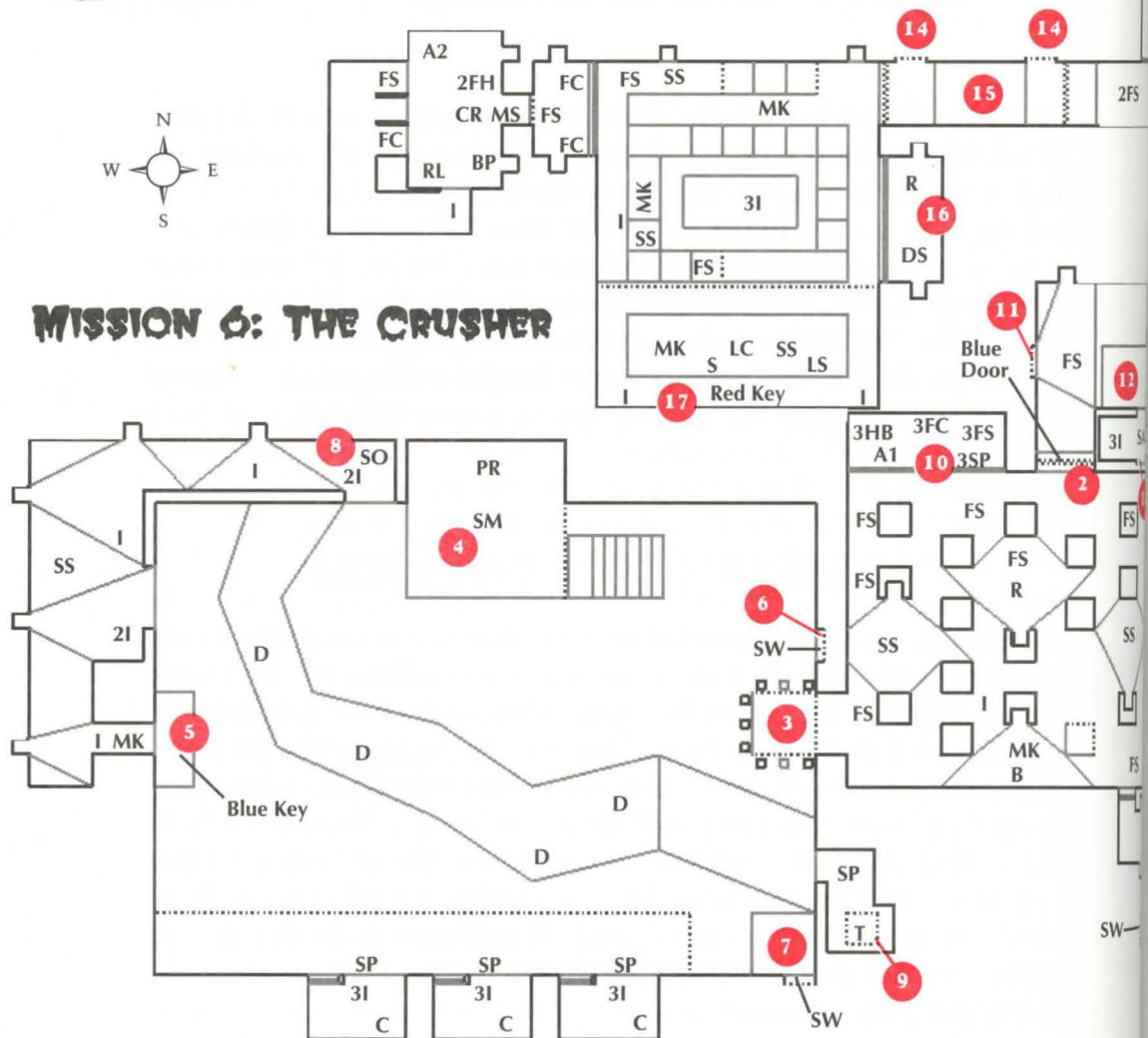
### MISSION 6: THE CRUSHER

You enter in a small room facing an open doorway to the west. Beyond the doorway you can see a darkened room full of pillars. You must move through this room to a lift on the southern end of the west wall. Between you and the wall, hiding behind pillars, are six Sergeants, two Imps, and a Revenant. Use the pillars for cover and move through the room, exorcising their souls with some well-placed ordinance. You will notice a blue door in the north wall. Stay on your toes so the enemies don't flank you. When they are dead, head for the lift. You will see that it has posts instead of walls and that it leads three stories down into a room with a stream of toxic waste running through it from northwest to southeast. In this stream are four Demons.

When you step onto the lift it will start to lower. As you descend, you will notice a raised platform in the center of the north wall protruding into the room. On it is a Spider Mastermind. The lift is in the center of the east wall, and in the west wall is a similar lift with no posts. On this lift you can see the blue key and some Imps. Along the south wall you can see a square platform in the southeast corner with a switch at the top. About 10 feet east is a lower platform that runs to the west wall. Along this platform are three stimpacks in front of three barred openings in the south wall with Imps lurking behind them. When the lift reaches the bottom, there will be a switch on the east wall right beside the lift. Get off, hit the switch—which causes a large structure over the Spider



## MISSION 6: THE CRUSHER



### The Bestiary

- D** Demon  
**FH** Former Human  
**FC** Former Human  
 Commando  
**FS** Former Human  
 Sergeant  
**I** Imp  
**HK** Hell Knight  
**LS** Lost Soul

- R** Revenant  
**S** Spectre  
**SM** Spider Mastermind

### Locations

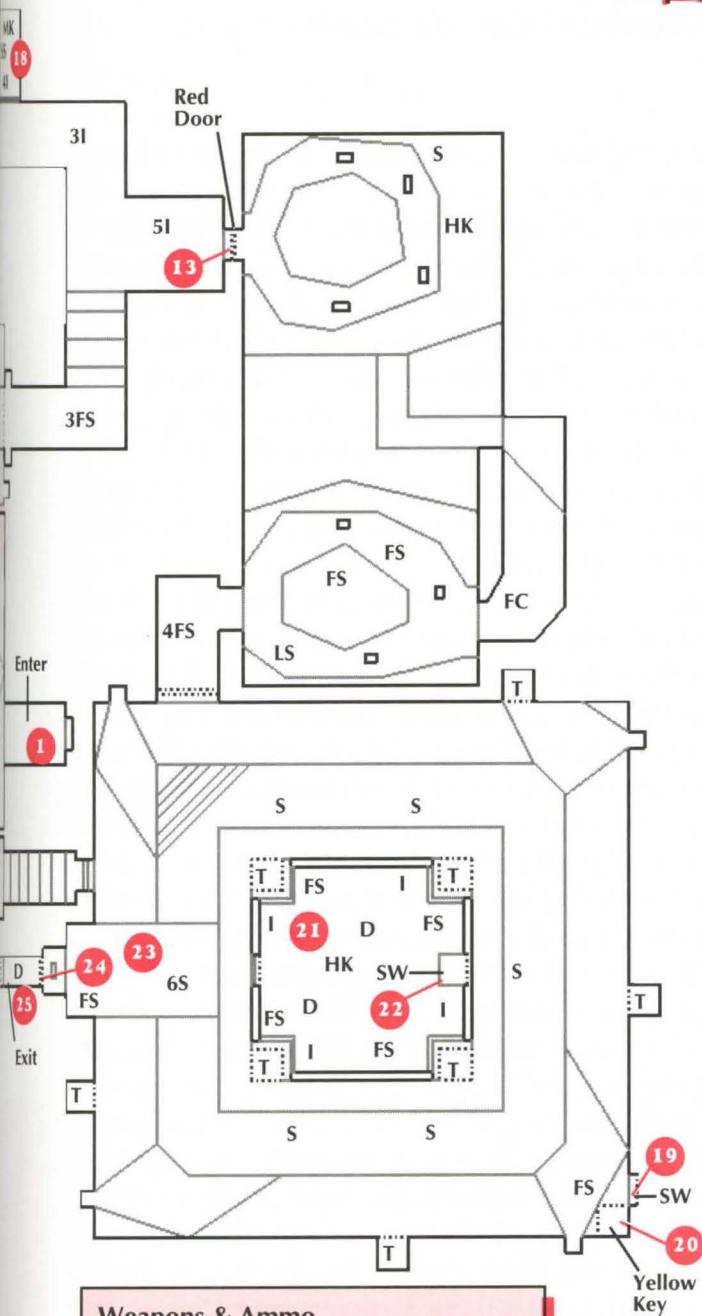
- SW** switch  
**T** transporter

### Locations

- SW** switch  
**T** transporter

### Special Items

- A1** green armour  
**A2** blue armour  
**B** berserker pack  
**C** energy cell  
**HB** health bonus  
**LC** large energy cell  
**MK** medikit  
**MS** megasphere  
**SO** soul sphere  
**SA** spiritual armour  
**SP** stimpack



### Weapons & Ammo

- CR** case of rockets
- DS** combat shotgun (super shotgun)
- PR** plasma rifle
- RL** rocket launcher
- SS** shotgun shells (4)

### Waypoints

- 1 Start
- 2 Blue Door
- 3 Lift platform
- 4 Platform with Spider Mastermind
- 5 Blue Key, platform lowered by (7)
- 6 Switch activates crushing ceiling above (4) to kill Spider
- 7 Switch lowers platform with (5)
- 8 Soul Sphere
- 9 Transporter takes you to (4)
- 10 Secret room with 3 stimpaks, 3 health bonuses and green armour
- 11 Switch lowers (12)
- 12 Raised platform
- 13 Red Door
- 14 Switch activates (15)
- 15 Platform raises and lowers quickly when activated by (14)
- 16 Hidden room opens when approached, losing 2 Revenants
- 17 Red Key
- 18 Secret room opens when approached, unleashing 4 Imps
- 19 Switch lowers (20) and opens walls behind teleport in (21)
- 20 Platform with Yellow Key
- 21 Room where walls behind teleports open when (19) is activated
- 22 Switch raises (23)
- 23 Secret platform
- 24 Yellow Door
- 25 Exit

Mastermind to slowly descend and crush him—then get back on the lift before it goes up.

Put your back against the posts on the north side and face the second post from the wall on the south side. When the lift reaches the top, you will notice the post you're facing is shorter than the others, creating an opening. Run and jump through it onto the square platform in the southwest corner. When you land, hit the switch as fast as possible. Turn to face the lift in the west wall with the blue key on it and run straight to it. You will probably have to cross part of the platform to the west of the platform with the switch, but don't stop to get the stimpacks—it'll slow you down. When you reach the lift, grab the key and ride it up. Be ready, there may be Imps at the top. Kill them.

Through the doorway, you see a hallway running north/south. Enter it and turn north. A short way down the hall you will see four or five Imps—kill them and continue to the north. The hallway will turn east, and at the end of the hall will be a soul sphere and an opening in the south wall. Grab the sphere and jump through the opening. You will land on the north side of the room with the toxic waste stream. Head for the southeast corner where the stream runs into the wall. Jump into the stream and enter the opening. Be quick, the Demons in the stream will be right behind you. Inside the opening are two stimpacks and a transporter, which will deposit you on the platform where the Spider Mastermind was. Grab the plasma rifle against the north wall and run down the stairs on the east side. At the bottom, go to the lift you entered on. Press **[Spacebar]** and the lift will lower. Ride it back up and reenter the room with the pillars.

Move to the north wall carefully. While you were gone, a panel opened in the north wall, releasing three commandos and three Sergeants. Mop them up and collect the goodies from the room they were in—three stimpacks, five health bonuses, and green armour. Go to the blue door and open it. On the other side will be a Sergeant in a hallway that goes north, then turns east and dead-ends. Kill the Sergeant and hit the switch in the west wall. This will cause the inside corner of the hall to lower. When you step on the platform, you will see an opening in the southeast corner. Through it is a room with three Imps and nine helmets. Enter quickly before the lift goes back up, kill the Imps, and get the helmets.



## Chapter 6 Intelligence Briefings

A switch on the south wall lowers the lift again. Get on and face east. When you reach the top, there will be a hall running east and then north. In the hall are three Sergeants—wipe them out and move to the turn in the hall. Face north, where there will be a set of stairs going down. At the bottom will be three Imps, quickly joined by two Sergeants. Kill them, then move to the bottom of the stairs in front of the opening in the east wall, and quickly retreat back up the stairs. This will draw out the five Imps lying in wait in the opening you just ran in front of. After killing the Imps, go back down the stairs.

In the alcove where the Imps were is a red door in the east wall—remember it, you'll be back. Continue north down the hall. It will turn west, and at the end you will see a door. Open it, and as soon as you go through the door you will see a dead-end section of hall with a switch in the north wall. Hit the switch and the last  $\frac{3}{4}$  of the hall will lower. At the bottom is a door in the west wall with a switch in the north wall beside the door. The switch will lower the platform again. When you open the door, you will see a hallway running west with a stairway beside it going up to the west. There is also a hall running south.

The inside walls of these halls do not reach the roof. On the stairs will be a Sergeant. Kill him and head up the short set of stairs with a walkway at the top. As soon as you step into the walkway, a panel in the west wall will open with two commandos and a Sergeant behind it. Kill them and continue down the walkway. When it reaches the west wall it turns south—here there will be an Imp on the walkway and another on top of the wall at the end. Proceed down the hall to the end where it turns east. There will be another short flight of steps leading up to a walkway continuing east.

There is a Sergeant on the steps. The inside wall of the walkway ends at this turn, allowing you to see a platform to the north of the walkway surrounded by toxic waste with three Imps on it. Kill all four bad guys using the end of the wall for cover. Wield a heavy weapon and head up the stairs. When you reach the platform, a panel in the east wall will open with three Revenants behind it. Retreat to the bottom of the stairs and let 'em have it, again using the wall for cover. Continue back up the stairs and down the walkway to the east, which will turn into a staircase climbing north, then east, then south. Go to the top.

To the east you will see a platform that is level with the top of the stairs. The center of this platform is hidden out of sight. Jump to the platform and get the red key in the center of the south wall. As soon as you land on the platform, it will start to lower. You can now see that in the middle are a Lost Soul, three Spectres, a large cell, four shells, and a medikit. At the northeast corner of the platform is a hall running north. Enter this, go down it about 10 feet, turn around, and kill the nasties as they come after you, then go get the goodies.

Return to the hall and follow it to the door. Open the door, go through, hit the switch on the north wall which will lower the platform, and ride it up. Open the door in front of you. Ahead in the north wall you will see an opening. Run past it and then turn around. This will draw out the four Imps inside so you can kill them. Once they are dead, enter the room they were in and get the items. Go back down the hall to the east. It will turn south, and on your left is the red door again.

Wield a heavy weapon and open the door. On the other side is a Baron of Hell. Kill him from the doorway using the walls as cover, then switch to a lighter weapon. You will see the Baron at one end of a room divided by a pool of toxic waste. There will be an L-shaped hallway running from the middle of this end into the east wall. A commando is heading your way along the walkway. Kill him and enter the room. Across the toxic waste to the south, on the other end of the room, will be two Sergeants and a Lost Soul. After dispatching them, follow the walkway to the east wall. Go through the opening and follow the hallway south.

At the end of the hallway there is an opening to the west. You will see a similar opening across from you in the west wall with three Sergeants coming out of it. Kill them, go out of the hall, grab the medikit on your left and cross to the opening in the west wall. When you enter, turn south and kill the Sergeant standing there. Go through the door in the south wall of this room. You will see a closed room in the center of this one on a raised platform. There will be a transporter on the outside of each corner of this room, and a closed door in the west wall. The platform forms a walkway around the room. Around the platform is a moat of toxic waste and around this is the platform you are standing on. In the southeast corner of this platform is a small raised section with the yellow key on it. Beside the key are a switch and a Sergeant.

## Chapter 6 Intelligence Briefings

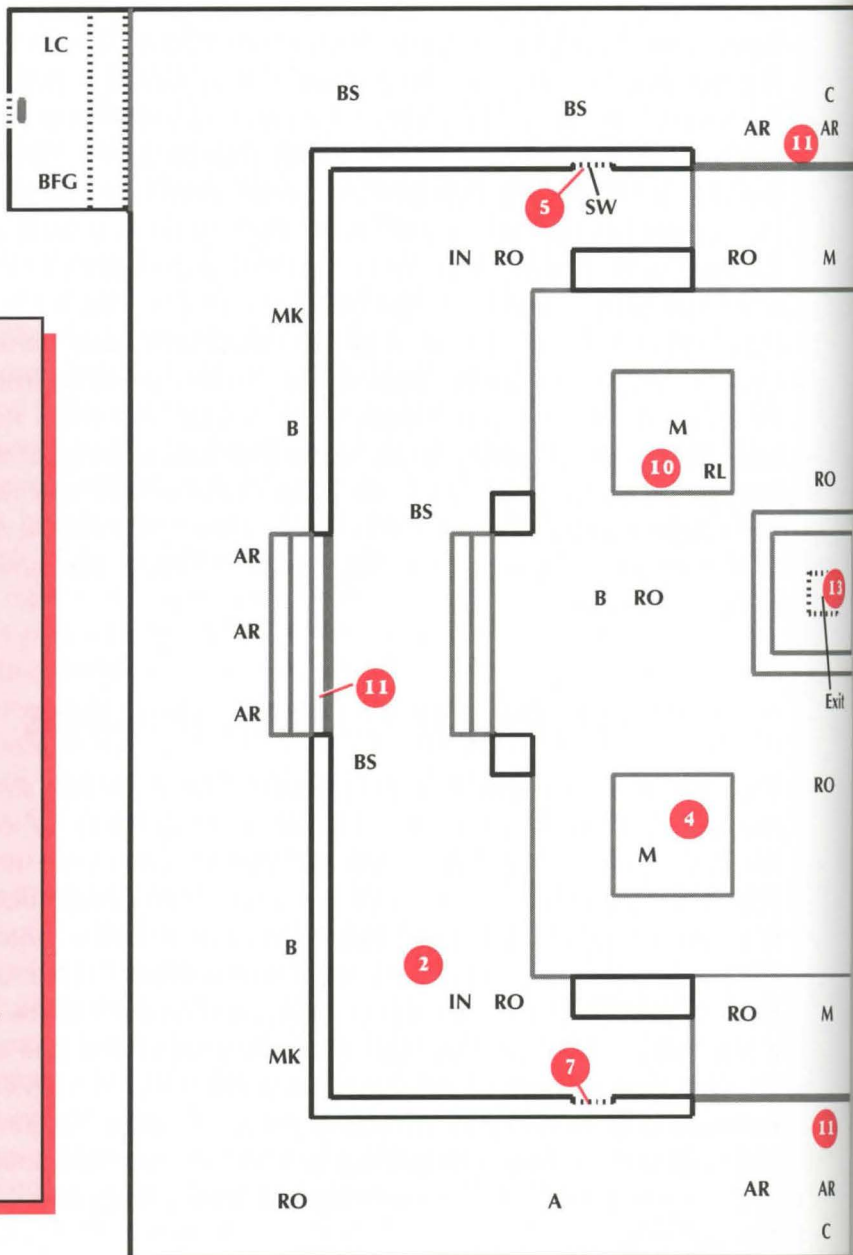
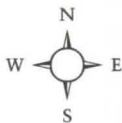
In front of you a set of stairs leads into the moat. The platform you are on is divided along the east wall by a section of the moat, and there are transporters in each wall. Go to the southeast corner where the switch is, kill the Sergeant, get your BFG ready, and activate the switch. Grab the key when it lowers and run down the platform to the west wall. Go west and stand in front of the transporter with your back to it. You will see that the wall separating the inside of the center room from the transporters in the corners has opened, as well as the door in the west wall, and the bad guys are using this to get to the transporters in the walls of the outer platform. Fire several bursts into the building and along the walkway to your right. When you see that most of the inhabitants have transported out, back up into the transporter behind you. Now you will be inside the center room. If there are any monsters left inside, blast them quickly, then head for the switch in the center of the east wall and trigger it. The missing section on the west side of the outer walkway will now rise, and you can jump to it through the door in the west wall. The yellow door will be in front of you. Open it, kill the Demon on the other side, and hit the exit switch behind him.

### MISSION 7: DEAD SIMPLE

You will be in a small room facing west. The walls will start to lower, revealing a supershotgun and a backpack. Grab these. When the walls are down you will be able to see that you are on a wide walkway that goes around a field. The walkway has a roof but the field doesn't. In the field are five raised platforms—one in the center with a switch on it you can't reach, and one in each corner. There is about 10 feet between the platforms in the corners and the walkway, and on each of the platforms is a Mancubus. Another Mancubus is on the ground and one each hovers between the platforms on the north and south sides. At each corner of the walkway you are on is an invisibility sphere. Scattered around the walkway and in the field are several rockets. In the north and south walls are two switches each. These switches will lower the platforms with the Mancubuses.

The best way to deal with this is to stay on the walkway, running

## MISSION 7: DEAD SIMPLE

**The Bestiary**

AR Arachnotron

M Mancubus

**Locations**

SW switch

**Special Items**

B berserker pack

C energy cell

IN invisibility sphere

IV invulnerability sphere

LC large energy cell

MK medikit

MS megasphere

**Weapons & Ammo**

A box of ammo

BFG BFG 9000

BP backpack

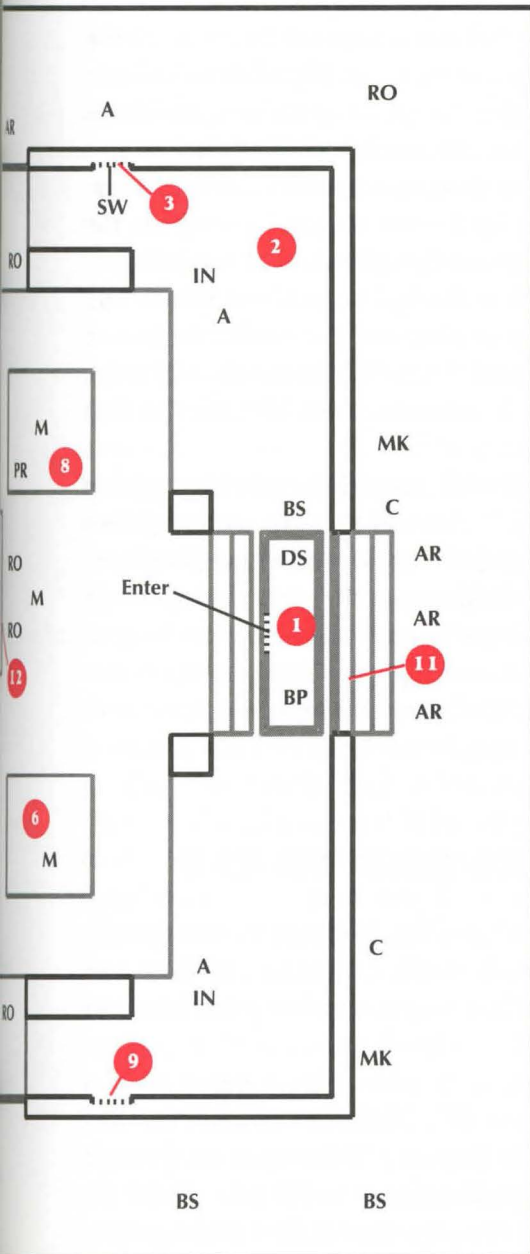
BS box of shells

DS combat shotgun (super shotgun)

RO rocket

PR plasma rifle

RL rocket launcher



### Walkthrough

- 1 Start
- 2 Invisibility sphere
- 3 Switch lowers (4)
- 4 Platform with Mancubus and megasphere
- 5 Switch lowers (6)
- 6 Platform with Mancubus and chaingun
- 7 Switch lowers (8)
- 8 Platform with Mancubus and plasma rifle
- 9 Switch lowers (10)
- 10 Platform with Mancubus and rocket launcher
- 11 Doors that automatically lift when all Mancubi are dead
- 12 Stairs which rise when all Arachnotrons are dead
- 13 Exit

around it and trying to grab one of the invisibility spheres. There are eight roof supports along the inside of the walkway. Keep running around the walkway, while periodically stopping behind a support to snipe at the Mancubuses. Do not stop too long or you'll be meat. If you don't kill one each time, at least you can slowly weaken them. Keep moving and sniping till there is only one left. Now run around and hit all the switches.

As the platforms lower, you will see they also contain the following: the northeast has a plasma rifle, the northwest a rocket launcher, the southeast a chaingun, and the southwest a megasphere. Grab an invisibility sphere, then the megasphere, and kill the last Mancubus. When you kill the last one and move near the center platform, the center section of each of the outside walls will lower and three Arachnotrons will enter from each side. Stand still for about 2 seconds, then bolt for the first opening you see to get outside.

On the outside you will see another wall around the complex, giving you a lane about 20 feet wide around it. Around this are scattered four cells, four medikits, some ammo boxes, shell boxes, and clips. Keep running around this lane, firing at the Arachnotrons through the openings where they entered. As before, don't linger in any one place too long or they will home in on you. When you have killed the last one, stairs rise around the center platform in the field. Grab any extra gear lying around, then go up the stairs and hit the switch to exit.

## **MISSION 8: TRICKS AND TRAPS**

In this level you can easily go astray and die. You begin in an octagonally shaped water pit. There are doors on every wall. All but two of them can be entered without keys. The door that is due east requires a red key, and the one in the northeast corner requires a yellow key.

Go to the southern door. You are about to enter a room with a Cyberdemon and 18 . . . yes, count 'em folks, 18 Barons of Hell. Get out your rocket launcher and prepare to stir them up. When you go through the door, you will be on a wide raised platform next to the pit with all the bad guys. On the forward right edge near the center is a soul sphere. Farther on, you can see an invulnerability powerup. Don't worry about

## Chapter 6 Intelligence Briefings

that for now. Grab the soul sphere and haul butt back to the door you came in. On your way out, lob a rocket round into the midst of the Barons, just to piss them off.

Go back out the door and change to the BFG 9000 quickly. At least one Baron will make it out with you, sometimes two. Give them a BFG enema and kick back for a little while. If you go to your overhead map, you can watch the remaining Barons duke it out with the Cyberdemon in the room you just left. Wait until the Cyberdemon is the only thing left moving in the room. He will always be the last one, but by the time the Barons finish with him, he is a shadow of his former self.

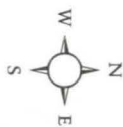
Reenter the room and toast the Cyberdemon with a final BFG 9000 round. Grab the box of rockets on the steps leading down to the pit, then get the yellow key from the alcove in the west wall. Go back up the stairs and get the invulnerability power up you didn't retrieve before. Immediately turn and run from the room. Once again, time is of the essence.

Go through the water pit to the yellow-key door. Open it and pick up as many of the six stimpacks in the alcove as you need. Run forward to the two gaps between the "columns" (you will understand the quotes in a minute) on the north wall. Grab an energy cell between each one. Switch to your plasma rifle and turn south. Run to the alcove where the red key is visible, but turn around and face north again before you pick it up.

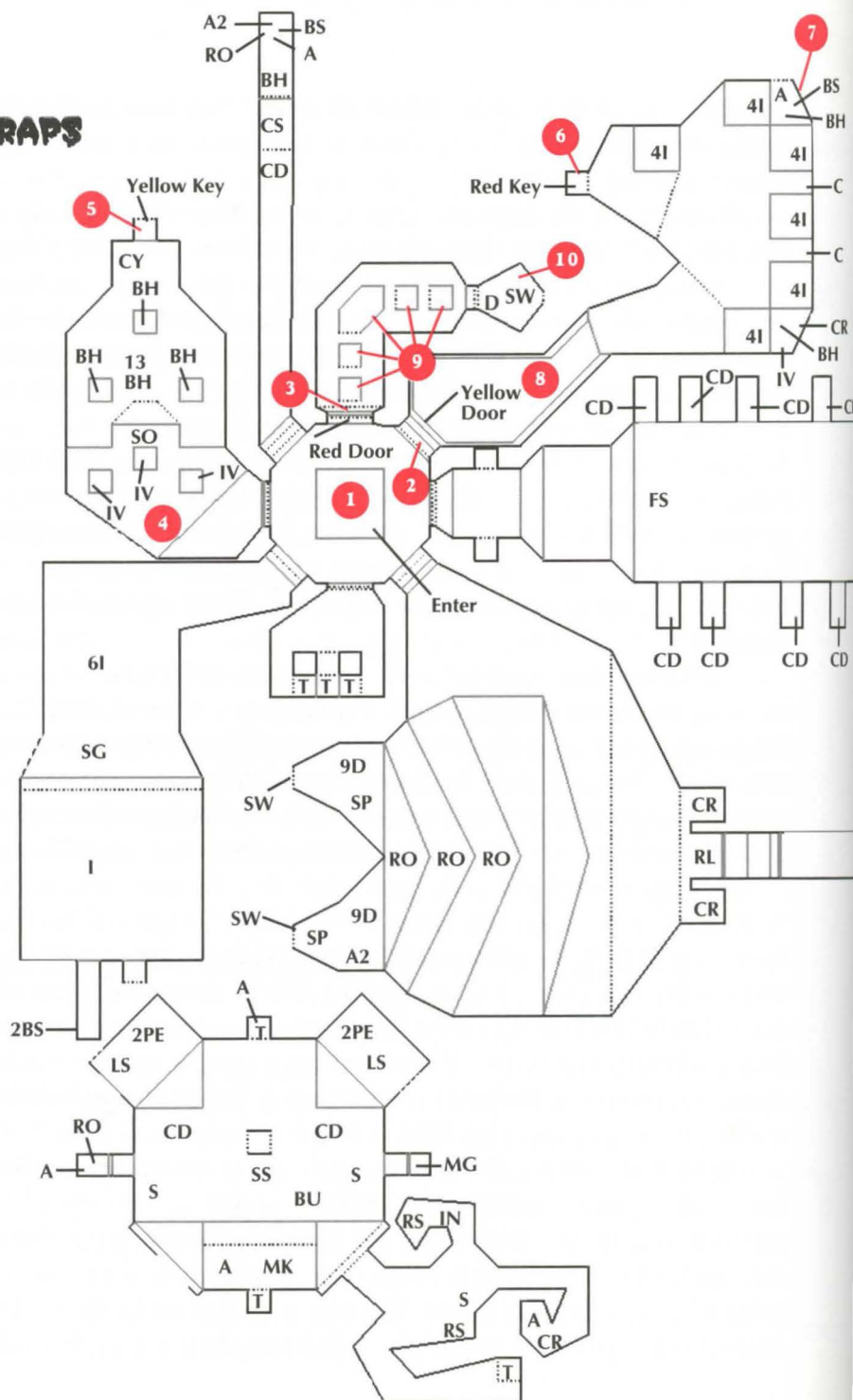
Back up into the alcove to retrieve the key. As soon as you do, all the "columns" in the room will lower, unleashing 25 Imps and two Barons of Hell. You only have a few precious seconds of invulnerability left so make every one count. Use the plasma rifle to sweep the room and mow them down. When things quiet down, your power up will be exhausted. Peer cautiously out of the alcove and mop up any stragglers. Go to the northwest corner of the room, picking up a box of shotgun shells and a medikit in the process, and throw the switch there.

Head east to the other corner, grab the powerup sphere there and turn south to return to the water pit. You can pick up any remaining stimpacks as you do so. When you get to the water pit, go to the red-key door. Behind it is an L-shaped room that curves to the right (north) with a series of descending platforms. The exit is in a room at the end of these platforms, but you must quickly leap from one to the next (Indiana Jones-

## MISSION 5: TRICKS AND TRAPS



Note: This map has been rotated 90° east





**The Bestiary**

- BH** Baron of Hell  
**CD** Cacodemon  
**CY** Cyberdemon  
**D** Demon  
**FS** Former Human Sergeant  
**I** Imp  
**LS** Lost Soul  
**PE** Pain Elemental  
**S** Spectre

**Locations**

- SD** secret door  
**SW** switch  
**T** transporter

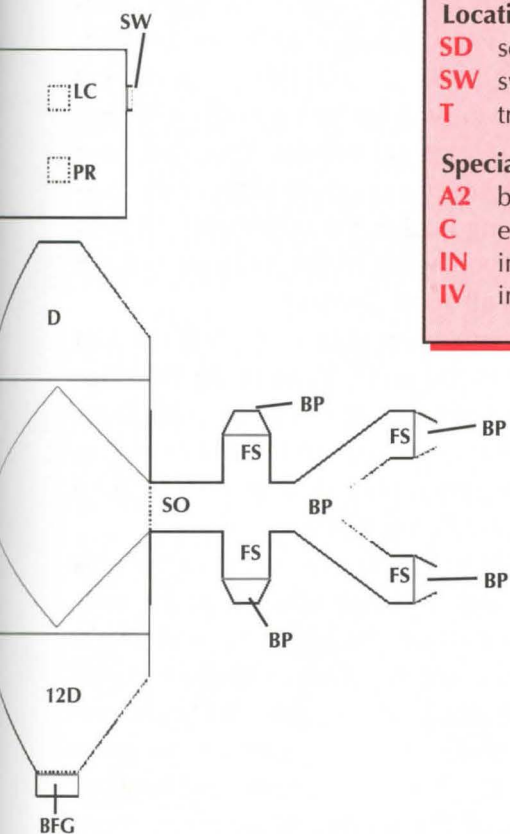
**Special Items**

- A2** blue armour  
**C** energy cell  
**IN** invisibility sphere  
**IV** invulnerability sphere

- LC** large energy cell  
**MK** medikit  
**RS** radiation suit  
**SO** soul sphere  
**SP** stimpack

**Weapons & Ammo**

- A** box of ammo  
**BFG** BFG 9000  
**BP** backpack  
**BS** box of shells  
**BU** bullets (10)  
**CR** case of rockets  
**CS** chain saw  
**MG** machine gun (chain gun)  
**RO** rocket  
**PR** plasma rifle  
**RL** rocket launcher  
**SG** shotgun  
**SS** shotgun shells (4)

**Walkthrough**

- 1 Start
- 2 Yellow Door
- 3 Red Door
- 4 Soul sphere and invulnerability
- 5 Yellow Key
- 6 Red Key
- 7 Switch lifts (8) back into place
- 8 Platform lowers after you cross into room, (7) raises it again
- 9 Platforms lower as soon as you step on them
- 10 Exit

style) to avoid sinking into the radioactive pit below. When you get to the door, open it and toast the Demon behind it. Flip the switch on the back wall, and it's Miller time!

## **MISSION 9: THE PIT**

You begin the level on a cross-shaped platform in the middle of a poisonous pit. There are four elevator platforms, one on each of the walls. Turn left and swim to the southwest corner. Press **[Spacebar]** to lower the platform. (Make sure your chaingun is ready.) Hop on and ride it up, turning to your right in the process. At the top, you will be facing north with one Imp, two Former Humans and a Pain Elemental nearby. You also have enemies sniping at you from other platforms on opposite sides of the poisonous pit. Don't stand still. Start spraying lead at the opponents on your platform and move north into the relative shelter of the hallway, but not all the way to the end, for reasons you will soon discover.

Turn and clear out the remaining enemies on your own platform. Get out your rocket launcher and turn back to the north. Walk up to the ledge at the northern end of the hallway, hugging the right wall as you do so. Let fly with one rocket round at the Baron of Hell in the room below, then back up immediately to avoid the green plasma balls he will send back at you. Repeat this five times and the Baron will be dead.

Turn back to the south. Hug the right wall until you come to the area that widens out from the hallway you are in. Point yourself at the platform ahead and to the left of you. Hold down the **[Shift]** key and take a running leap to that platform. Kill the Imp and two Former Humans. Grab the medikit and ammo on the platform. Back up into the southwest corner and take a running jump at the platform to the east in the same manner. Kill the Imps and Humans there, grab more ammo and healing, then back up into the southeast corner of that room and do it one more time, jumping to the north platform and continuing into the corner that is directly in front of you.

This next part is a little tricky, but just be patient. You essentially have three threats as you continue north: a group of eight Sergeants on the

## Chapter 6 Intelligence Briefings

other side of the wall you are hiding behind, another group of five Imps on a raised platform behind them, and a third group of Imps in the distance, slightly to the northeast once you step out into the north/south portion of the room you are in. Using the wall as cover, keep slipping out for a brief moment, wasting whoever is in sight, and sliding back behind the wall before their return fire can hit home. Repeat as necessary.

Once they are all cleaned out, go north to the second Imp platform. Just before you get to it, turn right and follow that wall to a switch on your right. Activate it, and a platform will raise to block the way you came in. Don't worry about it. Go to the west end of the platform where the Imp carcasses are strewn about and press **[Spacebar]**. When the platform lowers, hop on and ride it up. Press the switch on the west wall, and the back wall of the platform falls away, revealing a box of shotgun shells, a medikit, and a berserker powerup. Back into the northeast corner of this room and take a running jump to the new platform you just raised. Follow it to the east and step across to the platform with the stimpack on it.

You are about to embark on a perilous journey, so be swift on your feet. What you are about to do is stir up another hornet's nest. Turn east and hug the outside wall as you move forward. As you cross the threshold into the large open area, you should be running at full speed using your **[Shift]** key. Follow the outside wall and run around the entire perimeter of this area at least three times, inciting a riot as you do so. The room contains two Barons of Hell, two Mancubuses, four Cacodemons, and 16 Imps and Former Humans (not to mention the 15 monsters inside the center structure of this courtyard—but you don't have to go there unless you have somehow missed a BFG 9000 up till now). Work them all into a frenzy, then bail back out the door you came in.

Crossing this threshold for the second time releases a room with four Imps and a Spectre to the north of the platform you are on. Destroy them, scoot into the room they came out of, then hit the switch on the east wall. This opens another wall to the south, releasing eight more Imps and two Pain Elementals. God, is it getting hot in here?

Once they are down, go west into the newly opened room. Turn right and go to the switch at the north end. Activate it, and the left wall drops away. You are close to the first platform where you killed the Baron of Hell

**The Bestiary**

- BH** Baron of Hell  
**CD** Cacodemon  
**CY** Cyberdemon  
**D** Demon  
**FH** Former Human  
**FC** Former Human Commando  
**FS** Former Human Sergeant  
**I** Imp  
**HK** Hell Knight  
**LS** Lost Soul  
**M** Mancubus  
**PE** Pain Elemental

**Locations**

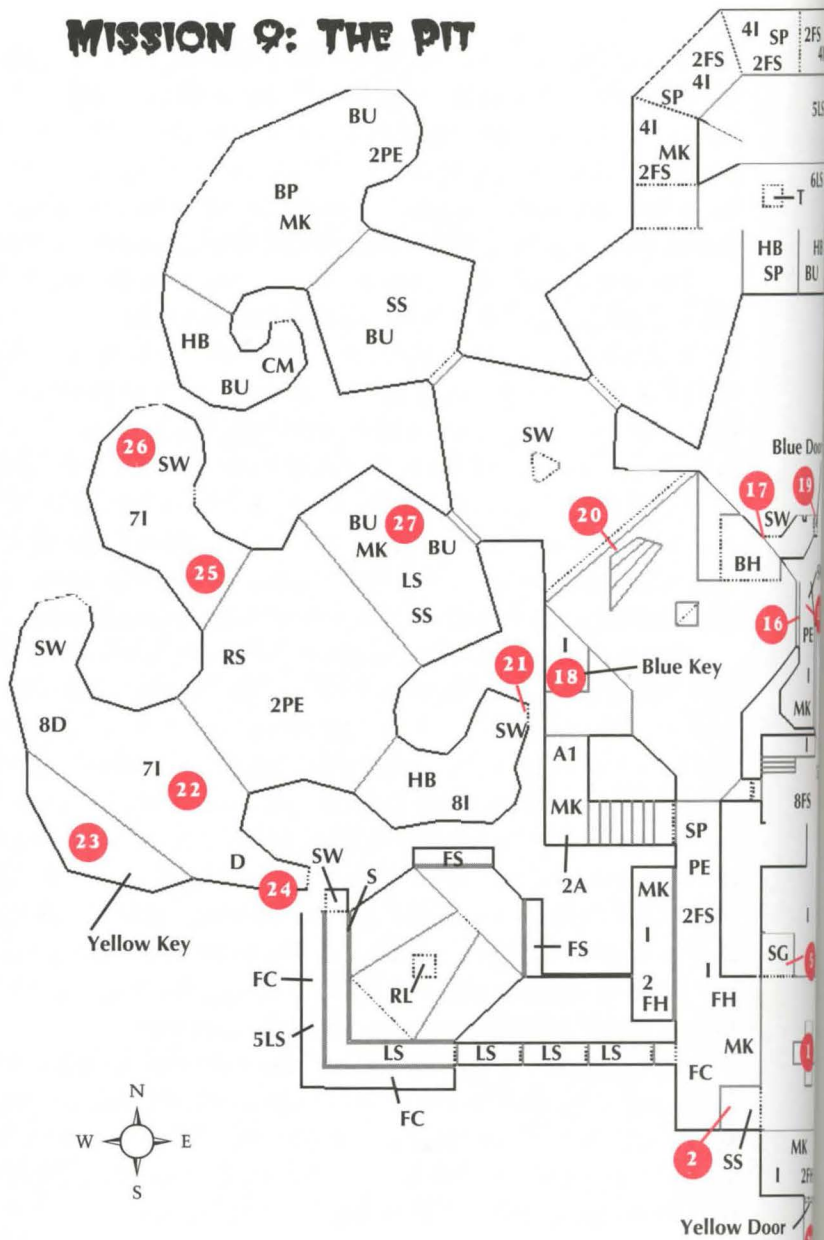
- CM** computer map  
**SW** switch  
**T** transporter

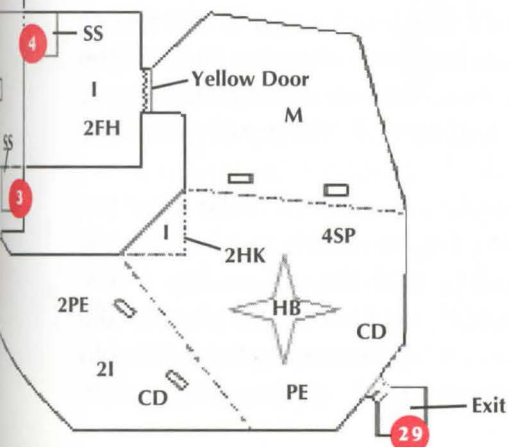
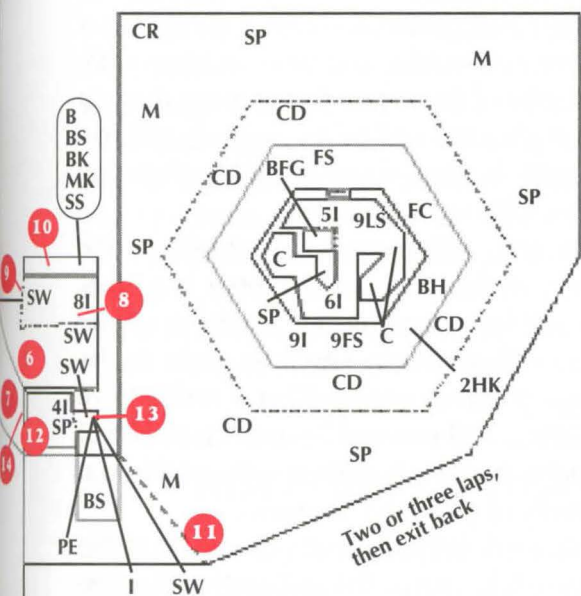
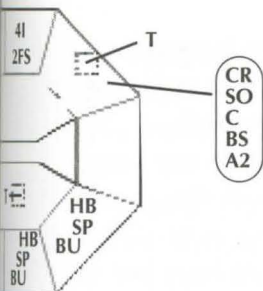
**Special Items**

- A1** green armour  
**A2** blue armour  
**B** berserker pack  
**C** energy cell  
**HB** health bonus (vials)  
**LC** large energy cell  
**MK** medikit  
**RS** radiation suit  
**SO** soul sphere  
**SP** stimpack

**Weapons & Ammo**

- A** box of ammo  
**BFG** BFG 9000  
**BP** backpack  
**BS** box of shells  
**BU** bullets (10)  
**CR** case of rockets  
**SG** shotgun  
**SS** shotgun shells (4)

**MISSION 9: THE PIT**



## Waypoints

- 1 Start
- 2 Elevator platform
- 3 Elevator platform
- 4 Elevator platform
- 5 Elevator platform
- 6 Switch raises (7)
- 7 Secret platform
- 8 Lift platform
- 9 Switch opens (10)
- 10 Secret room
- 11 Trigger which opens (12)
- 12 Secret room
- 13 Switch lowers (14)
- 14 False wall that drops away
- 15 Switch lowers (16)
- 16 False wall that drops away
- 17 Switch lowers platform with (18) on it
- 18 Blue Key
- 19 Blue Door with switch opens (20)
- 20 Secret Door
- 21 Switch lowers (22)
- 22 Platform
- 23 Yellow Key
- 24 Switch lowers (25)
- 25 Platform
- 26 Switch lowers (27)
- 27 Platform
- 28 Yellow Door
- 29 Exit

with rockets. Back away a little bit, take a run, and jump to the platform. When you land, hit the switch on your right and quickly turn around, running west to the blue key, which is on a platform you just lowered.

Kill the Imps if necessary, grab the key, and run out of the room through the door in the southeast corner. Retrace your steps in this area to get back to the Baron of Hell platform. This time, when you jump down, go to the back of the chamber behind the platform. Use the blue key to open the door there and trip the switch behind it. Turn quickly and run across the room up the flight of stairs that previously butted up against a brick wall. (*Note:* If these stairs are not visible, you have inadvertently crossed the blue pedestal in the center of the room. Just step on it again to bring the stairs back up again.) A platform will have lowered, and you can now enter the northwest wall. This is another one of the tough timing puzzles, but you can get it if you are willing to persist.

You are now in an odd-shaped room with three doors off of it: to the northeast, northwest, and southwest. In the center of the room is a triangular pedestal with a switch on each face. Use the one on the opposite side of the door you want and you will get there. Open the door to the southwest. You are now on a high platform overlooking a radioactive pond. Three other platforms are visible, and you will have to visit each of them eventually. As such, you should strafe each of them now to thin out the opposition (which consists entirely of Imps and Demons).

Once things have quieted a bit, back into the northern corner of the platform you are on and take a flying leap across the radioactive pond to the eastern chamber of the area you are in. Kill any remaining Imps, if necessary. Go to the back right corner of this room and trip the switch there. This lowers the platform on the southwestern chamber to the same level as the pond. Do this a couple of times to lure some of the opponents in that area down to your level and trash them. It will make life easier later on.

When you are comfortable that the coast is clear to make your run across the pond to the southwest platform, hit the switch and haul butt in that direction. Ride the platform to the top, grab the yellow key in the center of the room, and polish off any remaining Demons (a plasma rifle works well here). Go to the switch in the northern corner of the room. Hit it and haul butt, hugging the left wall on your way out. You should slide

## Chapter 6 Intelligence Briefings

around through the pit in time to catch the final platform to the top. Ride it up, kill any remaining Imps, and go for the switch in the back corner of this room. You have to repeat the same process you just completed to catch the platform you came in on and ride it back up. If you miss it, grab the rad suit that is waiting by the left corner, because you are going to have to repeat all three platform/switch combinations again to try it over.

At the top of the platform, take a deep breath. You are on the home stretch now. Exit to the northeast, then turn southeast and go to the wall. Activate the secret door by again pressing **[Spacebar]**. You are now back in the room where you collected the blue key. Go to the southeast corner, go through that door, and turn south toward the poison pit you started in. Dive in and go to the south elevator. Ride it to the top and go through the yellow-key door on this platform. Hug the right wall and run as fast as you can through this area. Everything from Imps to Mancubuses want to kill you before you can get out (be especially alert for Spectres lurking in the dark pit by the exit). Follow this wall, first south, then east to get to the exit in the southeast corner of the entire map. Go inside the door and throw the switch. It's over for now.

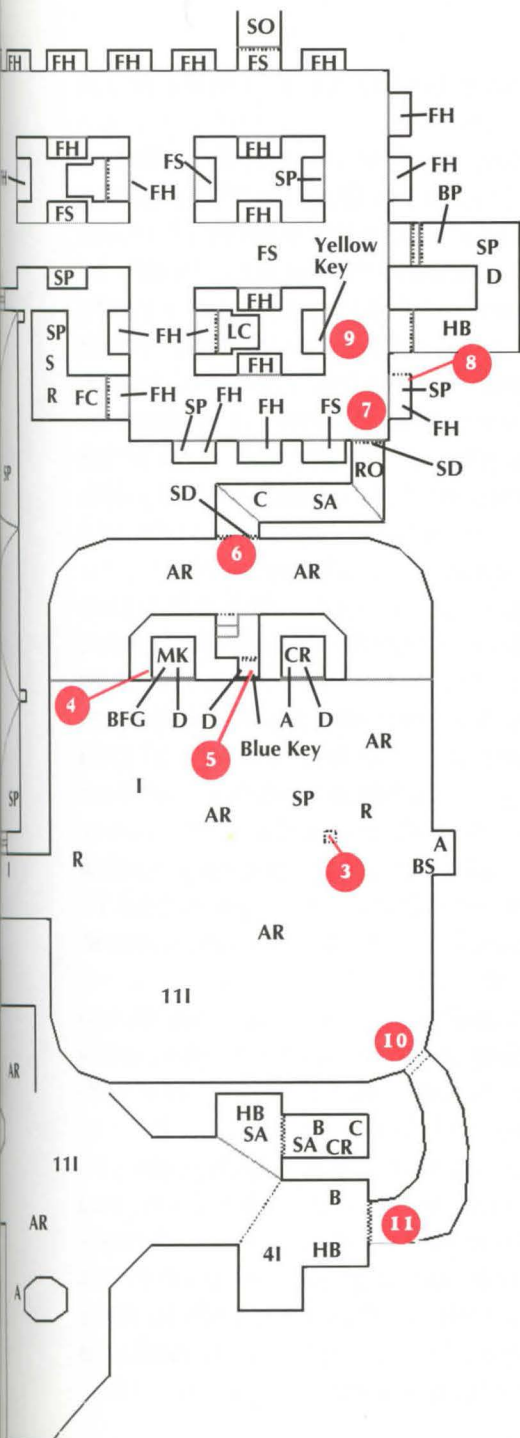
### MISSION 10: REFUELING BASE

You are in a hall facing east. In front of you is a set of stairs going down. At the top of the stairs on the right is a secret door. Open it and go down the hall that immediately turns east. A small room at the end of the hall contains a shotgun and some other goodies. Grab them and make your exit. When you come back through the secret door, turn east. Run as fast as you can down the steps, grabbing the box of shells on the run. There will be other stuff there, but don't stop to get it or you will be a target.

You will see a doorway in the east wall. Run through it. As soon as you clear that doorway, head for the doorway in the southeast corner of the room. You will have to run through many opponents, but don't stop. If you have to shoot, do it on the run. Once through the doorway, you will enter a hallway running north to south. Turn south and there will be four Former Humans and a doorway in the west wall, which will disgorge more baddies if you hang around. If you have taken damage, there is a







### The Bestiary

- AR** Arachnotron
- D** Demon
- FH** Former Human
- FC** Former Human Commando
- FS** Former Human Sergeant
- I** Imp
- HK** Hell Knight
- LS** Lost Soul
- PE** Pain Elemental
- R** Revenant
- S** Spectre

### Locations

- SD** secret door
- SW** switch
- T** transporter

### Special Items

- A1** green armour
- B** berserker pack
- C** energy cell
- HB** health bonus (vials)
- IV** invulnerability sphere
- LC** large energy cell
- MK** medikit
- RS** radiation suit
- SA** spiritual armour
- SP** stimpack

### Weapons & Ammo

- A** box of ammo
- BFG** BFG 9000
- BP** backpack
- BS** box of shells
- BU** bullets (10)
- CR** case of rockets
- CS** chain saw
- RO** rocket
- PR** plasma rifle
- RL** rocket launcher
- SG** shotgun
- SS** shotgun shells (4)

## DOOM II Hell on Earth

stimpack in the hall. You can scoop it up as you run by. Run to the end of the hall and open the door.

Don't even stop to take a breath. Keep running and you will enter an alcove, the other opening of which lets out into a large room containing two Revenants, two Arachnotrons, and a mixture of Former Humans, Sergeants and Imps. Move through the alcove into the room (east). As soon as you enter the room turn right and run along the wall going south. It curves to the east, straightens out, then curves back to the north. When you get to the second curve, turn northwest. You will see a stimpack. Head for it. On the north end of the room you will see two openings, one on each end of the north wall. As you pick up the stimpack, two secret doors open in the north wall and a Demon runs out of each. At this point, your best bet is to make tracks for the western opening in the north wall (all of the monsters should be gleefully dispatching one another).

Once you are through the opening, you will be in a hall that curves to the east. The next few steps must be performed precisely. Run down the hall, and you will see two Arachnotrons. Slip by the first one and go up the stairs in the south wall. As you are going up, a panel will open ahead of you to the left, behind which is the blue key. Run in and grab the key, then quickly turn around facing north. You will see a secret door that opened as you were going up the stairs. Jump off the platform you are on and go through the door. You will be in a hall that runs north a few feet and then turns east. Here you will find an energy cell and 18 spirit armour helmets. Collect these and take a breather—you deserve it. More importantly, you're going to need it!

The hall you are in will turn north and lead to a secret door. When you open this, you will see a hall running north and another one running west. Directly between them to the northwest, you will see a room with alcoves in the walls. In fact, all of the walls have alcoves and most of them are occupied. In the alcove on the east wall of the room is the yellow key. You must, as soon as the door opens, run out, grab the key, and return. Once again, shoot only on the run and don't waste time on anything that is not in your way. If you take too long and the door closes behind you, there is a switch on the north wall of the southern most alcove in the eastern corner (next to the secret door) which can reopen the door (provided you live long enough to activate it).

## Chapter 6 Intelligence Briefings

Once you are safely behind the door again, take a break and listen. If you don't hear the Arachnotrons, go back through the south door of the hall. Run! Follow the hallway west. It curves to the south and, as soon as you enter the room at the end of it, turn east. In the first alcove in the north wall will be the BFG 9000. Grab the gun, get out of the alcove, and take the path of least resistance to the southeast corner of the room. There you will find a secret door. Go through it.

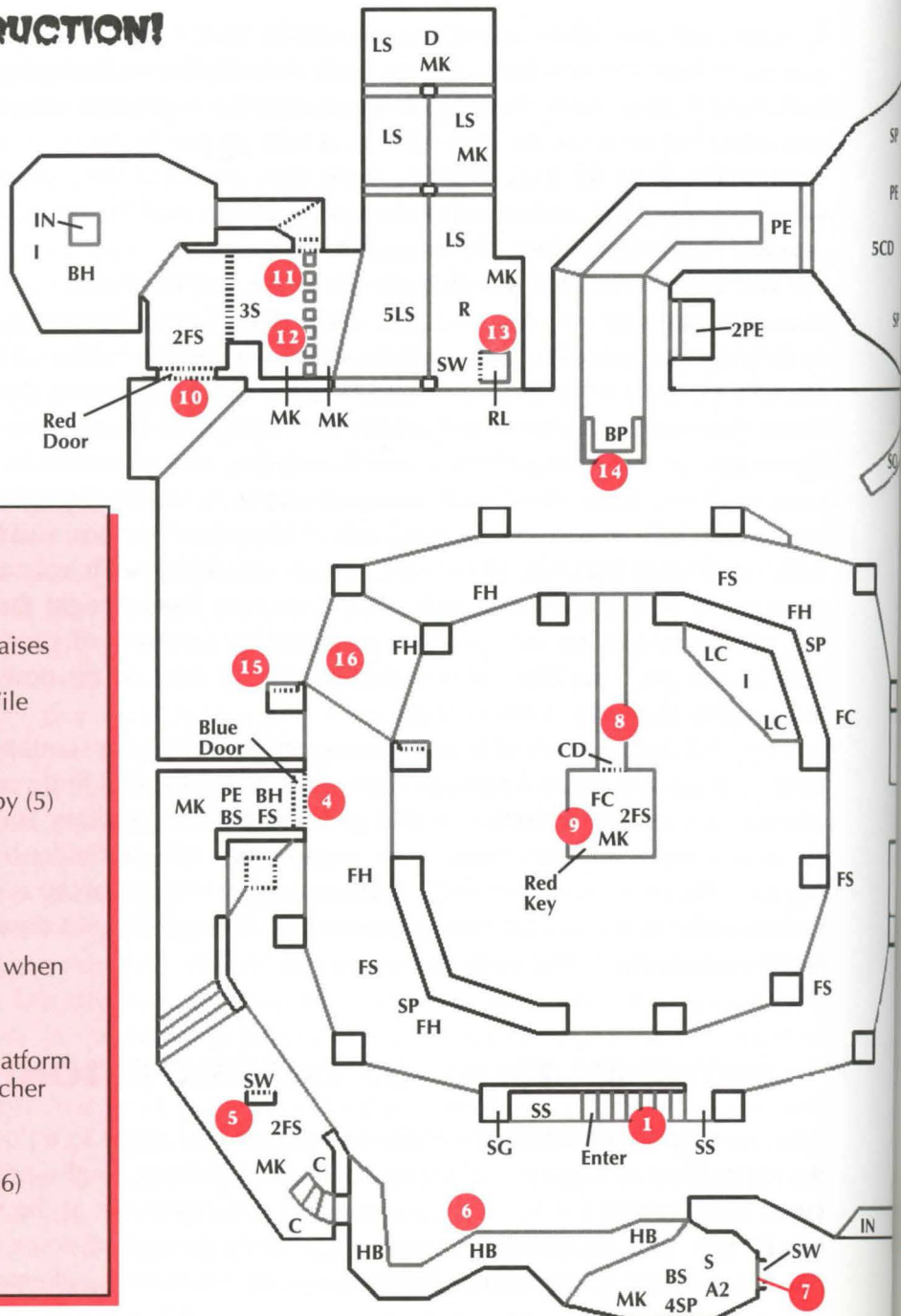
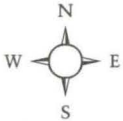
You will be in a hallway that curves to the southwest and ends at a door. You can pick up a stimpack and a pair of light amplification goggles in this hallway as well. Go through the door. On the other side is a room full of Imps and two Arachnotrons. Now is the time to whip out the BFG 9000. Fortunately, the Imps and Spiders are facing west (away from you). Open the door and run like the devil, avoiding any monsters in your path, until you reach the door in the west end of the room. Open it, and you find that the next room is chock full of Imps and Demons. Cut loose with one round from the BFG 9000, which should be sufficient to thin them out a little and clear a path. At a dead run, head straight through this room and out the yellow door, avoiding the survivors of your snap shot in the process. Now, if you thought it was bad up till now, rest assured that the worst is yet to come.

Any hesitation from this point forward guarantees instantaneous death. As soon as you are through the yellow door, you will find yourself in a small room. Turn northwest and go through the blue door. You will be in another small room running north and south, with a divider bisecting it on the same axis. Turn left (south) and go to the end of the divider. Go around it and head north at a flat run. Go through the exit door and hit the switch. Sayonara, baby, this one is over!

### **MISSION 11: 'O' OF DESTRUCTION!**

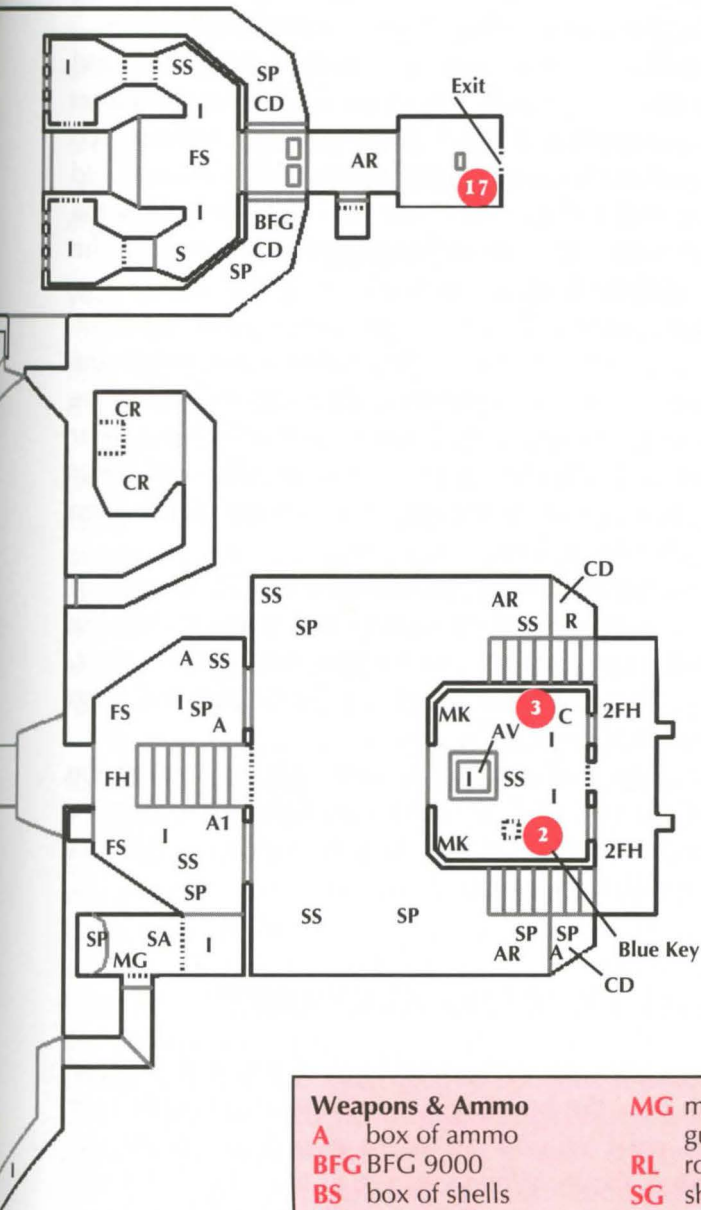
Enter, turn right, and follow the hall/platform until you come to a door on the right. Enter that room and go up the stairs. Continue south until you come to two sets of stairs. Both are guarded and come out at the same location, so you need only use one side both to go up and come back down. Go up the stairs to the platform above, then turn east and enter the

## MISSION 11: 'O' OF DESTRUCTION!



### Waypoints

- 1 Start
- 2 Blue Key
- 3 Column which raises when you enter, releasing Arch-Vile
- 4 Blue Door
- 5 Switch lifts (6)
- 6 Walkway lifted by (5)
- 7 Switch lifts (8)
- 8 Platform
- 9 Red Key
- 10 Red Door
- 11 Barricade opens when approached
- 12 Secret Door
- 13 Switch lowers platform with rocket launcher and (14)
- 14 Barricade
- 15 Switch lowers (16)
- 16 Platform
- 17 Exit



### The Bestiary

- AR** Arachnotron
- AV** Arch-Vile
- BH** Baron of Hell
- CD** Cacodemon
- D** Demon
- FH** Former Human
- FC** Former Human Commando
- FS** Former Human Sergeant
- I** Imp
- LS** Lost Soul
- PE** Pain Elemental
- R** Revenant
- S** Spectre

### Locations

- SW** switch

### Special Items

- A1** green armour
- A2** blue armour
- BP** backpack
- C** energy cell
- HB** health bonus (vials)
- IN** invisibility sphere
- LC** large energy cell
- MK** medikit
- SA** spiritual armour
- SO** soul sphere
- SP** stimpack

### Weapons & Ammo

- |                           |                                   |
|---------------------------|-----------------------------------|
| <b>A</b> box of ammo      | <b>MG</b> machine gun (chain gun) |
| <b>BFG</b> BFG 9000       | <b>RL</b> rocket launcher         |
| <b>BS</b> box of shells   | <b>SG</b> shotgun                 |
| <b>BU</b> bullets (10)    | <b>SS</b> shotgun shells (4)      |
| <b>CR</b> case of rockets |                                   |

door on that wall. Grab the blue key. Exit down the same stairs you came up. Continue straight until you leave the room, then turn left and follow the walkway to the west side. Use your newfound key to enter the blue door.

Proceed down the hall until you come to a switch. Activate it and continue on. Exit up the stairs at the end of the hall. You will come out on a walkway. Follow it to the room at the end. There you will find a switch on the east wall. Hit it and run back out of the room quickly. You should see a new stairway. Jump to it and go to the top. Turn right and follow the hall around to the north side. Take the walkway to the platform in the center. Get the red key, walk back across the walkway, and turn left.

Across from you in the northeast corner, you will see the red door. Jump down, run over, and enter it. Follow the hallway around to the right. A partition will open as you get close to it. Pass this and go up the stairs to the left. Follow that hall to the end, where you will find a pillar with a switch imbedded on it. Flip the switch, and the pillar will lower into the floor, revealing a rocket launcher and radiation suit. Grab them and jump off the ledge, continuing west.

You will soon see another switch on the wall to your left. Activate it, and a platform will lower. Jump on and ride it back to the top. Follow the hall to the northeast until you come to another walkway on your right. Go out on the walkway a few feet, then turn north. Take a run and jump to the platform in front of you.

Follow this corridor to the end and take a running jump through the opening in the center of the east wall. Go down the hole in the floor. At the end there will be another partition in front of you, which will open as you approach it. The exit is right in front of you.

## **MISSION 12: THE FACTORY**

As soon as you enter, grab the shotgun in front of you and proceed directly west. Once you pass the building, continue west but slide over against the left-hand wall as you do so to avoid fire from the Arachnotrons on the ledge above. When you get to the end, turn south but stay against the same wall. At the end of this wall, turn east and go up the stairs on your left.

## Chapter 6 Intelligence Briefings

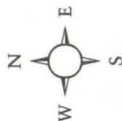
At the top of the stairs, follow the walkway to the north— here you will run into an Arachnotron. Kill it, ignore the one behind it since it is farther away, and enter the first door on the right. Go past the blue door and take the hallway to the south. In the east wall is a Mancubus. Kill him. At the end of the hallway turn right and go to the end to retrieve the blue key. Beware the Arachnotron on a platform above the key. Turn around and go back east down the hall. Turn north at the first left and enter the blue door.

As you go down this hall, sections will drop down (hopefully behind you). When you get to the end, turn around and kill the Sergeants in the room below you and jump off. In the southeast corner you will see a teleport pad, in the northeast corner is a backpack, and slightly in front of it is an alcove with a switch. Activate the switch, then enter the teleporter.

You will now be outside on a rooftop with a Mancubus. Watch out for Arachnotrons on the walkway below. Go to the southwest corner and jump down the hole—here you will run into six Lost Souls and a berserker pack. Follow the hallway to the end, then turn east and go into the door to your immediate left. Turn east and go to the southeast corner, where a secret door will reveal a Mancubus and the red key. Kill the Mancubus, hit the switch behind him, grab the key, and exit the main room the same way you came in.

Follow the hallway to the east, and at the end turn south—there will be six Mancubuses here, and a room in the southeast corner. Enter this room through the red door on the south side. Kill the commandos inside and grab the yellow key. Exit the room and turn west. Go down the hall until you come to the first cutoff. Go north and enter the blue door on your left. Drop down off the ledge and go to the teleporter in the southeast corner.

You will find yourself on the rooftop again. Jump off and go north. Enter the building on your left through the door on the east side. Open the yellow door and enter. You will be in a room with nine alcoves arranged around it. Each alcove contains a platform that goes up and down automatically, and on each platform is a Cacodemon and an energy cell. Activate the switches in each corner and the one in the left cubicle on the west wall. Exit the room through the door in the northeast corner. Follow that hall and enter the teleporter. You will come out in a room with a large hole and a walkway around it. Jump in the hole.



Note: This map has been rotated 90° west

**The Bestiary**

- AR** Arachnotron
- BH** Baron of Hell
- CD** Cacodemon
- FC** Former Human Commando
- FS** Former Human Sergeant
- I** Imp
- LS** Lost Soul
- M** Mancubus

**Locations**

- SW** switch
- T** transporter

**Special Items**

- A1** green armour
- B** berserker pack
- C** energy cell
- IN** invisibility sphere
- LC** large energy cell
- MK** medikit
- RS** radiation suit
- SP** stimpack

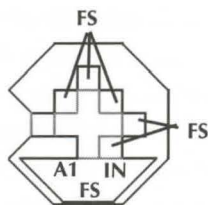
**Weapons & Ammo**

- A** box of ammo
- BFG** BFG 9000
- BS** box of shells
- BU** bullets (10)
- DS** combat shotgun (super shotgun)
- MG** machine gun (chain gun)
- SG** shotgun
- SS** shotgun shells (4)

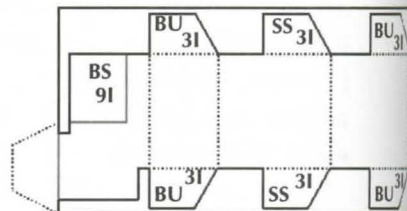
**MISSION 12: THE FACTORY**

1 Enter  
SG

2

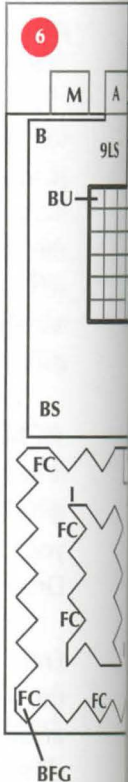
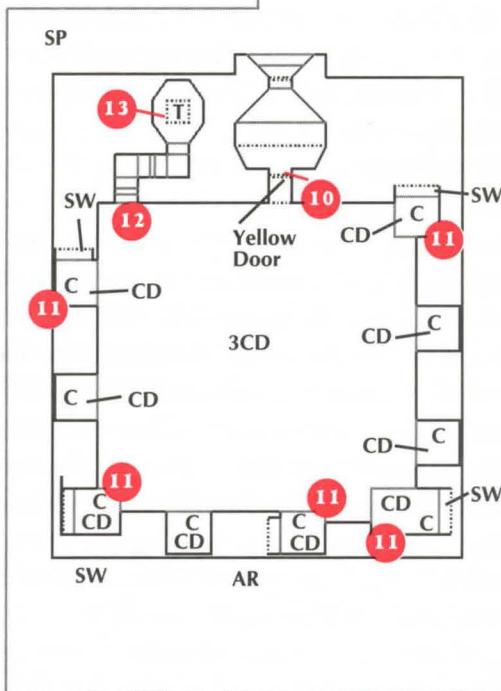


MK



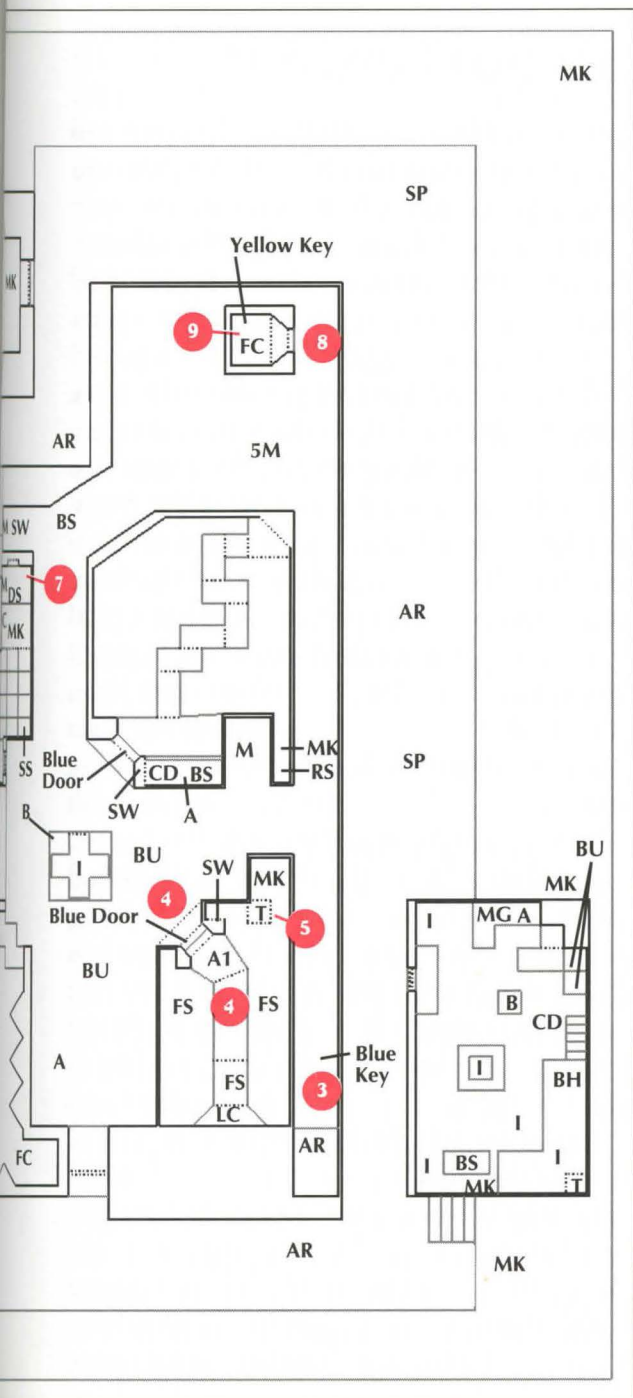
6

BS



MK





## Waypoints

- 1 Start
- 2 Shotgun
- 3 Blue Key
- 4 Walkway, drops away as you cross it
- 5 Transporter
- 6 Where (5) takes you
- 7 Red Key
- 8 Red Door
- 9 Yellow Key
- 10 Yellow Door
- 11 Switches (5 total, all must be triggered to open (12))
- 12 Secret corridor
- 13 Exit

## **MISSION 13: DOWNTOWN**

You will find yourself between two walls with a street running north and buildings along each side, with more streets between them. Anytime you are outside in this maze, move quickly or you will be subjected to heavy fire from all sides. Turn northwest, go around that wall, and turn southwest. You will see a large arrow with three health bonuses and one clip scattered around it. Grab them and follow the arrow to a set of stairs in the southwest corner. Go up the stairs, grab the four shotgun shells at the top, and go through the door on the right. You will step onto a platform with three health bonuses, overlooking a room with crates stacked up on it. Be careful, as there are six Imps and two Demons hiding among the boxes. You will also find a shotgun, shells, health bonuses, and stimpacks in this room. Proceed to the northeast corner where you will find a hole—jump into it.

You are now in a hallway that curves north. Be careful, halfway through you will encounter a Cacodemon. At the end of the hall is a platform. When activated it will lower and you can ride it to the top. You will now be in a room with three Imps. Kill these as well as a fourth one in an alcove in the southwest corner. Straight in front of you is a secret door behind which is a box of shells. Jump down the hole in the center of the north wall beside the transporter.

You will be in another hallway, this time running west, then north. West of you is a Demon. After killing it, go to the end of the hall and open the door on your right. To the east is a set of stairs climbing north/south, leading up to a platform. At the base of the platform are two health bonuses and a clip. To the northeast is a Mancubus. Fire at him and slip back into the hall repeatedly until he is dead. In the northwest corner of the room are two transporter platforms with the blue key in front of them. Grab the blue key but be careful not to step on the transporters. Did you hear what I said Mister! **DON'T STEP ON THESE TELEPORTS!** Turn around and go up the stairs.

At the top will be a door to your left and a transporter to the right. The top of this platform is a pool of toxic waste, so move quickly to the transporter. You will now be inside the second structure from the west on the north end of the compound. The room is shaped like a horseshoe with the ends facing south. There will be two Cacodemons in the room.

## Chapter 6 Intelligence Briefings

Kill them and collect all the boxes of shotgun shells on the west side, and the boxes of ammo on the east side. Face the interior wall on either side and hit `[Spacebar]`. The walls will rise, revealing another Cacodemon and the exit. Avoid the Demon and head out the door. Head west to the last structure on your left. It will have four corner posts and no walls. In the middle will be four transporter pads surrounded by spirit armour, energy cells, health bonuses, shells, and a couple of rockets. Grab all you can and jump on the transporter pads.

You will reappear on a walkway around the top of the building that is second from the west in the third row from the north. There are four Imps scattered around this walkway. Move forward about 10 feet, turn around, and take a running jump to the building to the south. You will land on a platform that is about 5 feet off the ground and runs all the way around the building. Follow this to the west side and enter the blue door. Inside are crates stacked around. There will be four commandos and a Lost Soul hiding among them. In front of you there will be an invulnerability orb resting on a crate. There is one crate between you and it. Jump to the first crate, then the second, grab the orb, and head for the transporter in the northwest corner.

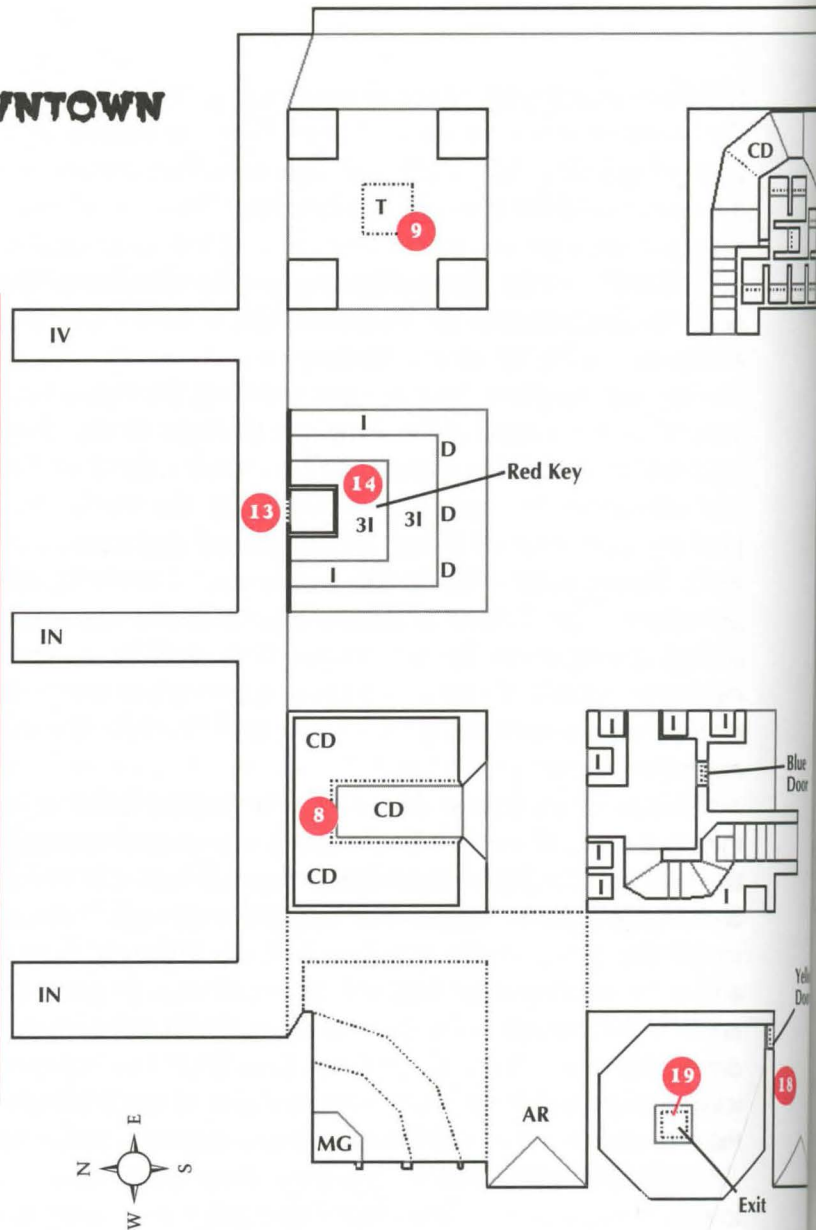
This will take you to the roof of the second building from the east on the north end. There will be three Imps, a case of rockets, a medikit, and the red key. Kill the Imps and grab the stuff before jumping off. Go to the building in the southeast corner of the compound. There will be a partial invisibility sphere on the way—grab it. Open the red door in the west wall and back up. Two Spectres will come at you. In the room on both the north and south walls there are platforms with three levels on top of each other getting smaller as they go up. Each level has Imps on it. Reenter the room and go to the northwest corner, shooting south till you have killed all the Imps on the south side, then reverse the operation for the north side.

Against the east wall is a platform. As you approach it, it will begin to lower. Don't stay too close, but if you get too far away it will stop moving. As it lowers, kill the three Imps on it and get on. You will find a berserker pack. When the platform reaches the top you will see the yellow key on the top level against the north wall. Jump to it. You will now be able to see supplies on the levels where the Imps were. Grab them as you jump down and exit the room.

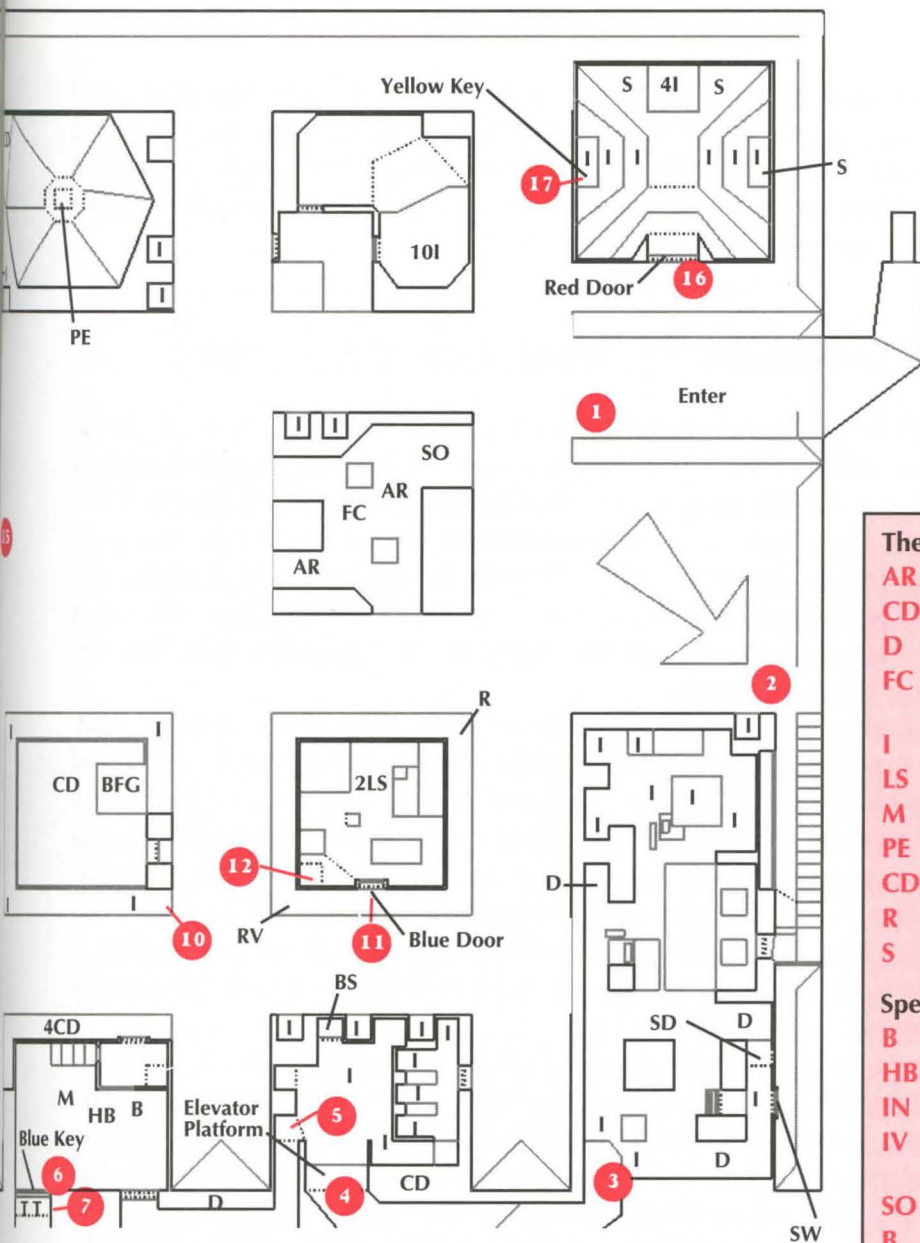
## MISSION 13: DOWNTOWN

## Waypoints

- 1 Start
- 2 Stairway
- 3 Hole in floor leading to sunken hall
- 4 Lift platform
- 5 Hole in floor leading to another sunken hall
- 6 Blue Key
- 7 Transporter
- 8 Where (7) takes you
- 9 Transporter
- 10 Where (9) takes you
- 11 Blue Door
- 12 Transporter
- 13 Where (12) takes you
- 14 Red Key
- 15 Invisibility sphere
- 16 Red Door
- 17 Yellow Key
- 18 Yellow Door
- 19 Exit



Note: This map has been rotated 90° west



### The Bestiary

- AR** Arachnotron
- CD** Cacodemon
- D** Demon
- FC** Former Human Commando
- I** Imp
- LS** Lost Souls
- M** Mancubus
- PE** Pain Elemental
- CD** Cacodemon
- R** Revenant
- S** Spectre

### Special Items

- B** berserker pack
- HB** health bonus
- IN** invisibility sphere
- IV** invulnerability sphere
- SO** soul sphere
- B** berserker pack

### Locations

- SD** secret door
- SW** switch
- T** transporter

### Weapons & Ammo

- BFG** BFG 9000
- BS** box of shells
- MG** machine gun

There will be a wall in front of you. Turn north, then west at the end of the wall. Turn right at the last street running north, cross one street and at the next you will see the yellow door in the building in the northwest corner. Enter here, where you will see a large hole in the center of the room. Jump in to exit.

### **MISSION 14: THE INMOST DENS**

You will be facing east, standing on a walkway running north/south, looking at a wall with windows. Turn south and in front of you will be a box of shells, and in the southwest corner will be a stairway. At this point the walkway turns east—kill the two Former Humans in front of you. Turn around and go down the stairs. As soon as you enter the stairway, the outside wall opens and the stairway curves to the left. You will see a commando on a raised platform in the southwest corner. Kill him and continue down the stairs.

In front of you are two Sergeants standing in a walkway running east. Along the right wall is a red door and a catwalk running south with a red barrier blocking it. Go to the east end of the walkway and turn north where there is another walkway going north. In the middle of this is a walkway going east with a door about six feet away. There are platforms on either side of the door with a commando on each. Turn down the walkway after killing the commandos. The door will open, releasing a Revenant, and as many as five Lost Souls will come up over the sides of the catwalk. Waste all the bad guys.

There will be another door in front of you, which will also open as you approach. Ahead is a black building. The walkway runs up to the building, then runs around it on both sides. There will be four Imps in front of you and more shooting at you from windows in the building. Kill the Imps, follow the walkway around to the south side of the building, and enter through the door. Pray that all four of the Imps inside are dead.

There is a chaingun in the middle of the room. Through a window in the north wall a walkway extends out of a wall across from you. Kill the Imp and three commandos standing on it, then take a run and jump to it. You will pass through a wall. Turn right and kill the two Sergeants on the

## Chapter 6 Intelligence Briefings

platform to the east. Continue north where you will see an opening into a hallway running east/west. Run in and back out—this will attract the Former Humans and Sergeants on both sides to the opening where you can gun them down.

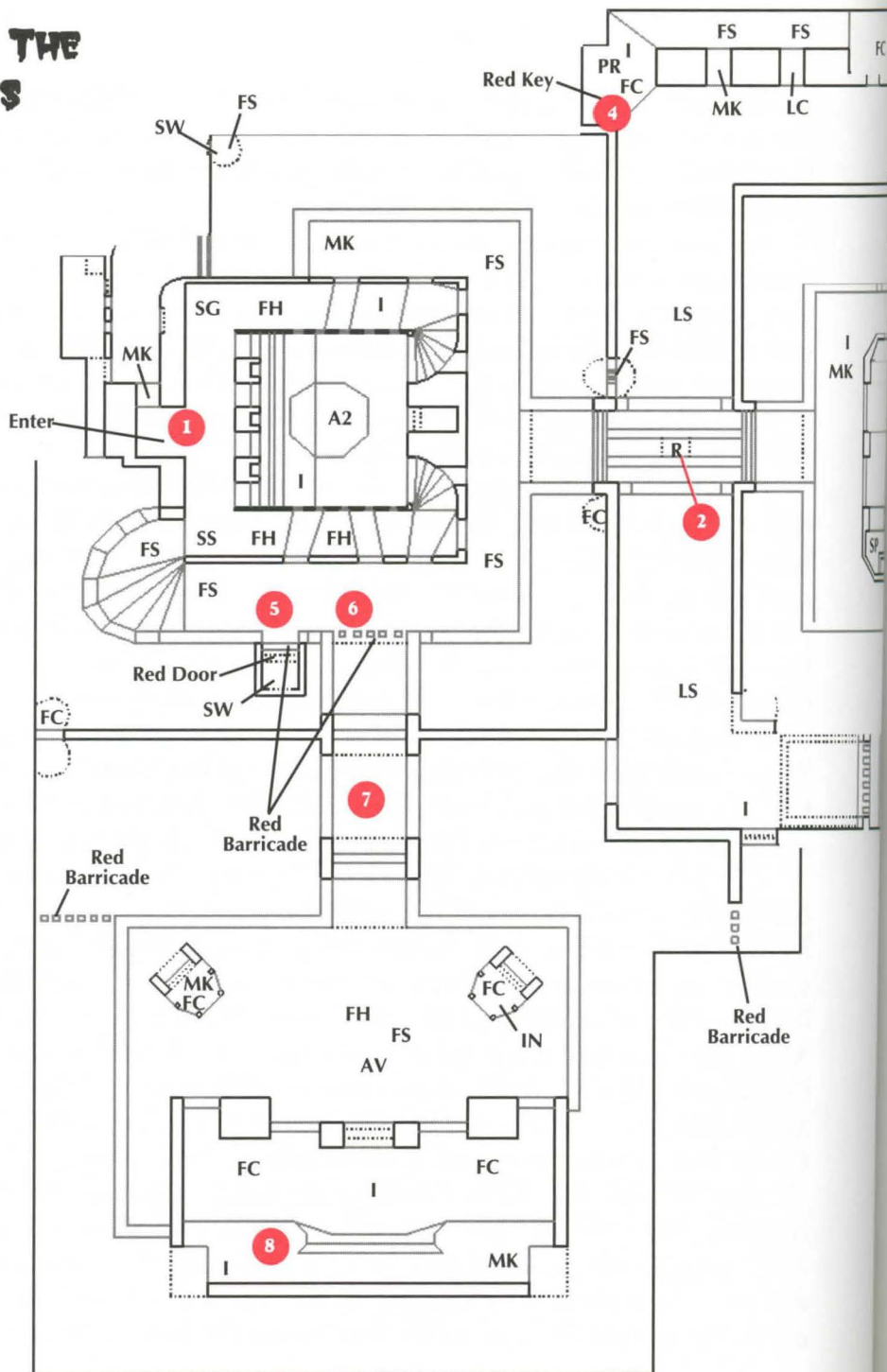
Go back into the hall and head west. At the end of the hall you will find the red key and a plasma rifle. Now head back down the hall to the east. Along the right wall are two alcoves, one with a medikit and one with a large cell. Continue east to the walkway where you entered. Turn down that walkway, run to the end, and jump to the walkway across from it. You will be facing a building, and the walkway will run east/west. Follow it west to the end and then south.

On your right will be the walkway with the doors where the Revenant was. Go back across this. At the end turn left and then right. You will be back at the red barricade, and to the right of it is the red door. Open the door, run in, and flip the switch. This will lower the barricade and allow you to cross the catwalk. This one is set up the same as the one with the Revenant between the doors, but the space between the doors is empty. Grab your BFG. When the second door opens, start firing—an Arch-Vile, three Sergeants, and seven Former Humans are lurking behind this portal. Three rounds from your BFG should take them all out. However, on each side is a small guard shack with a commando inside. Switch back to a smaller weapon and kill them now so you don't get caught in a crossfire.

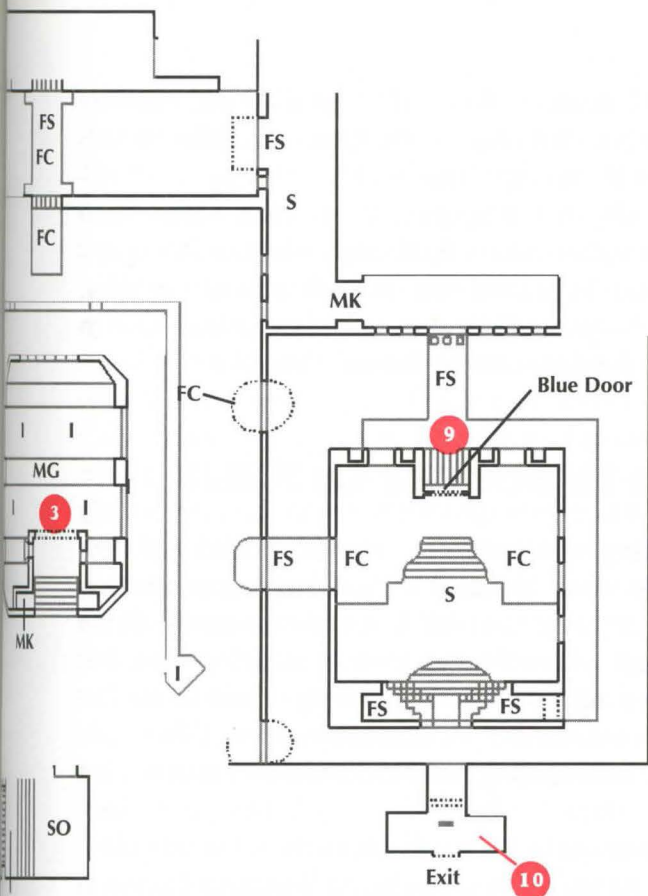
On the back side of these towers are lifts with a door at the top. The one on the west side contains two medikits, and the one on the east has an invisibility orb in it. Grab the orb and go through the door in the wall south of you. There are four Imps and four commandos in here. The BFG may have taken out some of the commandos, but the rest is up to you. Along the south wall is a ledge accessible by a set of stairs in the center. On the east end is a medikit, and on the west is the blue key. Get the key and retrace your steps to the catwalk where you killed the Revenant. Cross it and go to the south wall of the building in front of you.

Enter the door, run across the room, and jump to the catwalk you see out the window, just like you did last time. When you go through the first wall, jump off into the water on your right and head for the platform due east. When you get to it, hit `[Spacebar]` to lower part of it so you can ride it up. At the top get off, turn south, and follow the hall, which will turn

# MISSION 14: THE INMOST DENS







### Waypoints

- 1 Start
- 2 Catwalk with doors on each end which open on approach
- 3 Chain gun
- 4 Red Key
- 5 Red Door hiding switch which opens (6)
- 6 Red barricade
- 7 Catwalk with doors on each end which open on approach
- 8 Blue Key
- 9 Blue Door
- 10 Exit

### The Bestiary

- AR** Arachnotron  
**AV** Arch-Vile  
**FH** Former Human  
**FC** Former Human Commando  
**FS** Former Human Sergeant  
**I** Imp  
**LS** Lost Soul  
**R** Revenant  
**S** Spectre

### Locations

- SW** switch

### Special Items

- A2** blue armour  
**C** energy cell  
**IN** invisibility sphere  
**MK** medikit  
**SO** soul sphere  
**SP** stimpack

### Weapons & Ammo

- MG** machine gun (chain gun)  
**PR** plasma rifle  
**SG** shotgun  
**SS** shotgun shells (4)

east. Continue down the hall, grabbing the medikit on the floor. Halfway to the end of this hall is a catwalk to the south. Cross this, kill the two Sergeants on the other side, and enter the blue door.

Down the stairs in front of you is a Spectre. Waste him. Across from you, you will see a door. On either side of it, through window like openings, you will see two Former Sergeants, one on each side of the door. Kill them and run to the door—you will have to run because you have to cross a small drop-off. Open the door and hit the switch to exit.

### **MISSION 15: INDUSTRIAL ZONE**

You are in a small room facing south with four medikits in front of you. Turn east and go through the door. You will be standing in an elevator. Hit the switch, move to the center of the platform, and face south. At the bottom you will see the street with a Former Human standing in it. Kill him and move into the street. Turn west and follow the street to the last building. Watch your back—there are guards everywhere. When you come to the far corner at the last building, ease around it and take out the two guards.

From here you will see a tower to the south. Head for it but stay alert, there are enemies closing in on you. When you get to the tower there will be a metal plate building beside you to the east. In the southwest corner of this building is a stairway. You will see that the outside wall is open. The staircase goes around the building, climbing one floor per side all the way to the top. At each corner is a landing with bad guys sniping at you. The first landing, which you can see as you are running for the stairs, has a Sergeant and a commando on it. The second has a Sergeant. On the top floor you will find a rocket launcher, a case of rockets, and two stimpacks. Don't grab them just yet. You will see two Imps, one on the tower you just passed and one on a building to the north. You will also see a Sergeant on a building to the northeast. Kill all three, then collect the goodies.

Next take a running jump to the tower the Imp was on. There is a transporter on it, and as soon as you land you will appear on a ledge on the building to the northwest of the one you just jumped from. In front of

## Chapter 6 Intelligence Briefings

you will be the Sergeant you shot from the last building. As you proceed down the ledge to the east you will see a window in the wall to your left. On the other side is a Sergeant—kill him. When you get to the end of the ledge you will see an opening in the south west corner of the building to the east one floor below. Back up and take a running jump to it.

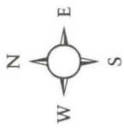
When you land, there will be a switch right in front of you. Activate it, turn north, and drop into the room and get to the southeast corner ASAP. Enter the transporter. There will be a couple of medikits beside it, which you should grab if you can. Don't take too long as there is a Cacodemon on your butt. When you step off the transporter, you will be on top of a building in a small room with three stimpacks around you. Grab them and reenter the transporter. You will be back in the room with the Cacodemon, but you will be standing on some boxes looking at the red key on another stack of boxes in front of you. Grab the key and head for the northwest corner of the room. Step onto the platform. It will lower you into an alcove leading to the street.

At the opening go east, keeping on the lookout for patrols. Follow the street to the next intersection and turn south. Ahead of you will be a building with men patrolling a ledge on the third floor—watch out for them. You need to get to the southeast corner of the building on your left. Here you will find a switch and a lift. Activate the switch and the lift will lower. Get on and ride it up. You will be in front of a red door. Open it and back off the platform. There will be several Imps on the other side of the door. Once back on the ground activate the switch, and the lift will bring down a load of Imps for you to kill. Repeat this procedure till the lift comes down empty, then ride it up. There may still be an Imp or two at the top, so watch out.

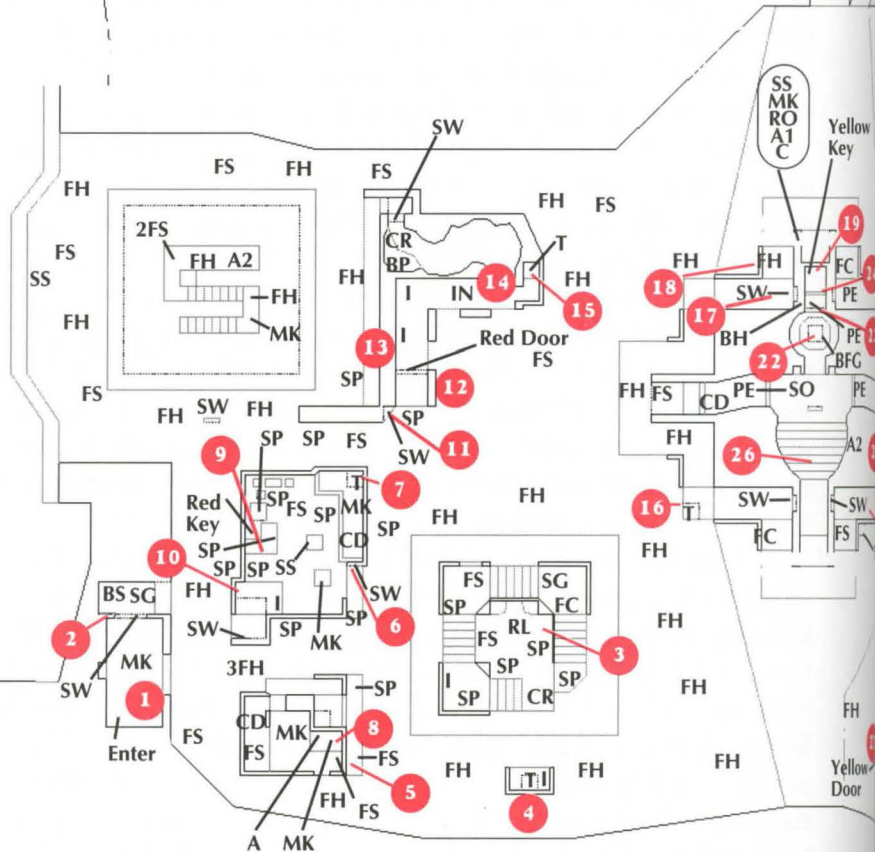
You will see a hallway that goes east, then south. Follow this, but be careful when you turn south—there will probably be an Imp standing there. There will also be a stimpack in the corner for you. At the end of the hall running south there will be an invisibility artifact—grab it and turn left. Take the teleport that appears.

You will be on the third-story ledge where you saw the patrols before. Go east, following the ledge around the building. You will pass a large door with a skull and a pentagram on it. Keep going. At the end of the hall

## MISSION 15: INDUSTRIAL ZONE



Note: This map has been rotated 90° west



### The Bestiary

<b>AR</b>	Arachnotron
<b>BH</b>	Baron of Hell
<b>CD</b>	Cacodemon
<b>FH</b>	Former Human
<b>FC</b>	Former Human Commando
<b>FS</b>	Former Human Sergeant
<b>HK</b>	Hell Knight
<b>I</b>	Imp

<b>LS</b>	Lost Soul
<b>PE</b>	Pain Elemental
<b>R</b>	Revenant
<b>S</b>	Spectre

### Locations

<b>CM</b>	computer map
<b>SW</b>	switch
<b>T</b>	transporter

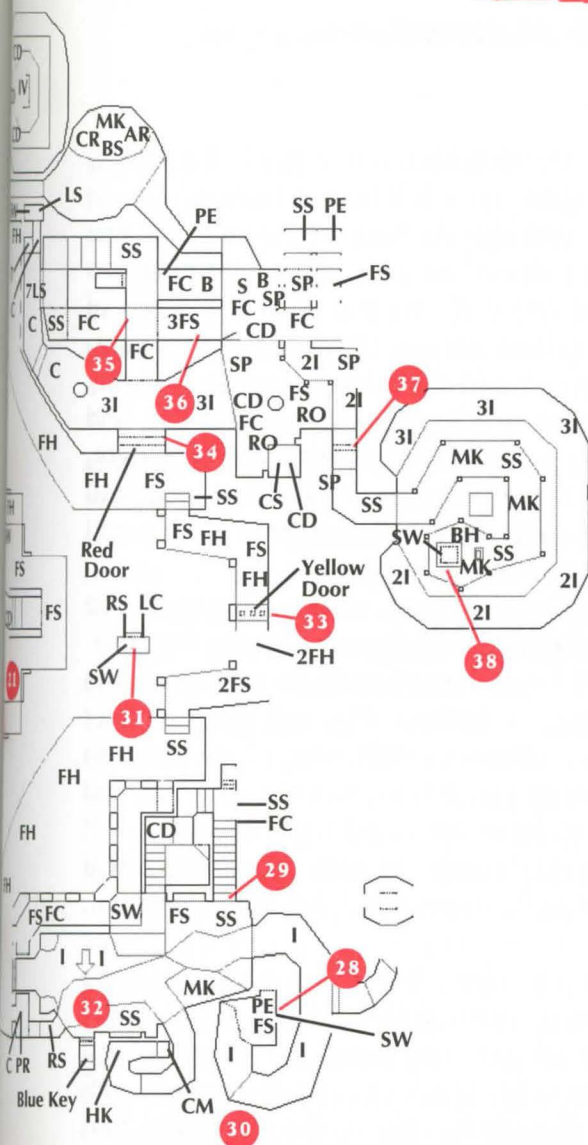
### Special Items

<b>A1</b>	green armour
-----------	--------------

<b>A2</b>	blue armour
<b>B</b>	berserker pack
<b>C</b>	energy cell
<b>IN</b>	invisibility sphere
<b>IV</b>	invulnerability sphere
<b>LC</b>	large energy cell
<b>MK</b>	medikit
<b>RS</b>	radiation suit
<b>SO</b>	soul sphere
<b>SP</b>	stimpack

### Weapons & Ammo

<b>A</b>	box of ammo
<b>BFG</b>	BFG 9000
<b>BP</b>	backpack
<b>BS</b>	box of shells
<b>CR</b>	case of rockets
<b>MG</b>	machine gun (chain gun)
<b>RO</b>	rocket
<b>SG</b>	shotgun
<b>SS</b>	shotgun shells (4)



### Waypoints

- 1 Start
- 2 Switch and platform
- 3 Rocket launcher and other goodies
- 4 Transporter
- 5 Where (4) takes you
- 6 Switch
- 7 Transporter

- 8 Where (7) takes you, step in other teleport in same room
- 9 Where (8) takes you
- 10 Platform which lowers you to the ground
- 11 Switch lowers (12)
- 12 Lift platform
- 13 Red Door
- 14 Invisibility Artifact
- 15 Transporter
- 16 Where (15) takes you
- 17 Switch lowers (18)
- 18 Lift platform
- 19 Cache of supplies
- 20 Switch lowers (21)
- 21 Lift platform
- 22 BFG 9000
- 23 Secret door, behind which is Baron of Hell
- 24 Secret door, behind which is Pain Elemental & Yellow Key, entering also raises (25) from the floor
- 25 Switch which raises (26)
- 26 Secret stairway
- 27 Yellow Door
- 28 Switch opens (29)
- 29 Secret door leading to stairs
- 30 Switch lowers lift it is on
- 31 Switch reveals (32)
- 32 Secret door, behind which is the Blue Key
- 33 Yellow barricade
- 34 Red Door
- 35 Secret door, opens on approach
- 36 Secret door, opens on approach
- 37 Blue Door
- 38 Exit

you will see a switch in front of you and a lift on the left. Hit the switch, and the lift will lower with a commando on it. Kill him and get on.

At the top continue following the ledge. As soon as you make the first right there will be a guard and an alcove on your right containing two medikits, one 100 percent armour, one cell, one rocket, and one box of shells. Grab the goodies and continue around the ledge to the right. There will be another lift. Cross over it and drop down through the hole. You will drop one story and be next to a Former Human. Kill him and move on, following the ledge. You will pass another door on your right, but ignore it also and continue down the ledge. At the end, you will come to another switch and lift. Activate the switch, and the lift will lower with a Sergeant on it. Kill him and ride it to the top.

Still following the ledge, at the first right there will be what looks like a hallway. At the end is a drop-off into an empty room with the BFG visible in a small room at the west end. Grab your heaviest weapon (not the rocket launcher), jump down and grab the BFG. This will open a secret door in the west wall, releasing a Baron of Hell. Mash him and turn around quickly. Through the doorway you will see two Cacodemons and two Pain Elementals that seem to have appeared from nowhere. Kill them, then turn back around and go through the secret door. There will be another secret door in the west wall behind which is a Pain Elemental, the yellow key, and a medikit.

Turn around and head west. You will see a box with a switch. Opening the second secret door brought this up from the floor. Hit the switch and a set of stairs will rise from the floor, allowing you to exit the same way you came in. Once you are back on the ledge, turn south and retrace your path till you come to a lift, then jump through the hole on the other side. Turn right. Off the south end of the building you will see a moat of toxic waste. On the south west corner is dry land. Take a running jump to it.

Go to the northeast corner of this area and open the yellow door in the south wall. Watch out for snipers. The room on the other side is inhabited by four Imps and two Sergeants. Through the middle flows a stream of toxic sludge leading into three tunnels. Head into the one on the northeast wall, where you will find a rad suit. Follow the sludge back through the room and into the tunnel in the south wall. This passage is

## Chapter 6 Intelligence Briefings

guarded by two Imps and winds around to a platform guarded by a Pain Elemental and a Sergeant. On the platform are some shotgun shells and a switch. Activate the switch and exit the tunnel.

Be careful as you reenter the main room. There will be a commando in it now and a set of stairs in the south east corner. Follow these stairs to the top. Halfway up you will encounter a Cacodemon. At the top will be a switch on your right. It will lower a lift, which you can ride to the top. You will be on a parapet running north and west. You must go to each end, watching out for guards, and activate the switches you find there. Return to the lift and step off the south end. You will now be back on the stairs. Follow them back down to the main room. You will now see, beside the tunnel in the northeast corner, a recess in the wall. This is a secret door. Open it and get the blue key.

Exit the room through the door in the north wall. Go to the southeast corner of this section, where you will find an enclosed walkway that crosses the sludge moat. Go through it. Watch out for guards. In the middle is a yellow barricade. Open it and continue on. When you come out, you will be in front of a red door. Open it and step to the side. Inside are three Cacodemons, two commandos, three Sergeants, and several Imps. Keep opening the door and shooting them till they are all dead.

Directly across from the door in the east wall is an alcove. When you enter it the east wall will open, revealing a hall. Follow this hall. It will lead to a set of stairs going up in three short flights that wind to the left with a landing between each. Be careful at every turn as there are bad guys lurking around the corners. At the top is a hallway with a wall at the end. It will raise as you approach, revealing three Sergeants and two commandos. Kill them and move on. The raised wall opens onto a platform with a secret door directly across from you in the south wall. There will be a stimpack on the platform, but be careful. As you come to the platform you will see on your right, one floor higher, a barred wall with Imps behind it. Kill all of them that you can see. It may save your life later.

Go through the secret door. You will enter a stairway like the first. (Remember, be careful at the landings.) The stairway will open onto a hallway that leads to a blue door. Open this door, pick up the two stimpacks on the other side, and go to the corner. Looking around the corner

to the south you will see a barred wall in the south end and a Baron of Hell on the other side. This would be a good time to use all the rockets you found. As you open fire you will notice there is another Baron to the right of the first. Kill him also. Now haul butt through this hall. It will wind around in a circle. There is another hall on the outside of this one with Imps in it firing at you, so don't slow down. At the end is a small pool of what looks like sludge. Jump in.

**(icon)Note:** There is one secret mission accessible through mission 15, and another supersecret level off of that one. For details on how to access these missions, go to Mission 31 at the end of this chapter.

## **MISSION 16: SUBURBS**

If you are fleet of foot and your god is with you, it may be possible for you to live through this. You will start in a small room facing south. In the west end of the room is a set of stairs going up to a platform above you. On this platform are several Imps. At the foot of the stairs is an alcove in the south wall. In this alcove is a door in the east wall. Run for the door. When you open it you will see a Revenant in front of you. To the south is another building and there is a wall around both buildings. Run to the right of the Revenant toward the east side of the building onto the south. Run to the south end of this building where you will see a doorway in the southern end of the other wall. Go through the doorway and head west.

In the southwest corner will be a pool of toxic waste. In the southeast corner of the pool is a tower with a stairway winding around the outside to the top. There are Imps on the stairs and at the top of the tower. Charge at the tower, firing on the Imps as you run. All hell will break loose to the north, and monsters will start pouring out from everywhere. Remain calm. Run up the stairs to the top of the tower. Grab the cases of rockets and the blue key, which you will find here.

Jump off the tower and run east. Fire on anything in your way, but don't slow down. You will pass the door in the wall around the two buildings you just came through. Do not go through the door, but follow



## Chapter 6 Intelligence Briefings

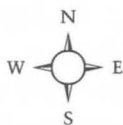
the wall as it turns north. At the north end the wall turns west. Here you will encounter a set of steps running up in to a building to the north. On the steps will be a Revenant. It's a good thing you picked up all those cells on the last level. Warm up your BFG and let him have it.

Charge up the stairs and through the doorway in the north wall of the landing at the top. This room will have no walls on the north and east sides. Turn left and blast the three Demons standing in front of the door in the west wall. Go through the door and unleash the BFG again. This should take out at least two of the three Revenants standing here. Give them another touch if necessary. To the southwest you will see the blue door. Go through the door and kill the two Spectres inside. The red key will be sitting in a window in the south wall. Go back out the blue door to the main room and exit through the same door you came in.

Once through the door, run to the east wall and jump off. In the northeast corner you will see what appears to be a series of stacked cubes. They will form a corner, with one stack protruding into the corner. Activate these and they will lower to the ground, releasing two Revenants and two Imps who were hiding in open areas on the north and east sides of the cubes that lowered. Back off and let them clear out. **KEEP MOVING OR YOU ARE DEAD MEAT.** Once these guys have moved out, activate the stack of cubes again and move into the opening to the north. Turn east and activate this stack of cubes. It will lower to the ground, allowing you to climb on top and ride it up. At the top you will see a walkway below you to the north and west with a wall behind it. Jump down to the walkway and turn around to face the cubes you just rode up. Activate them and ride the stack back down, stepping off into the same opening you were in before. This will have caused the wall behind the walkway to rise, releasing 21 Imps. The Imps will now be on the edge of the walkway embroiled in combat with all the monsters who have congregated around the cubes.

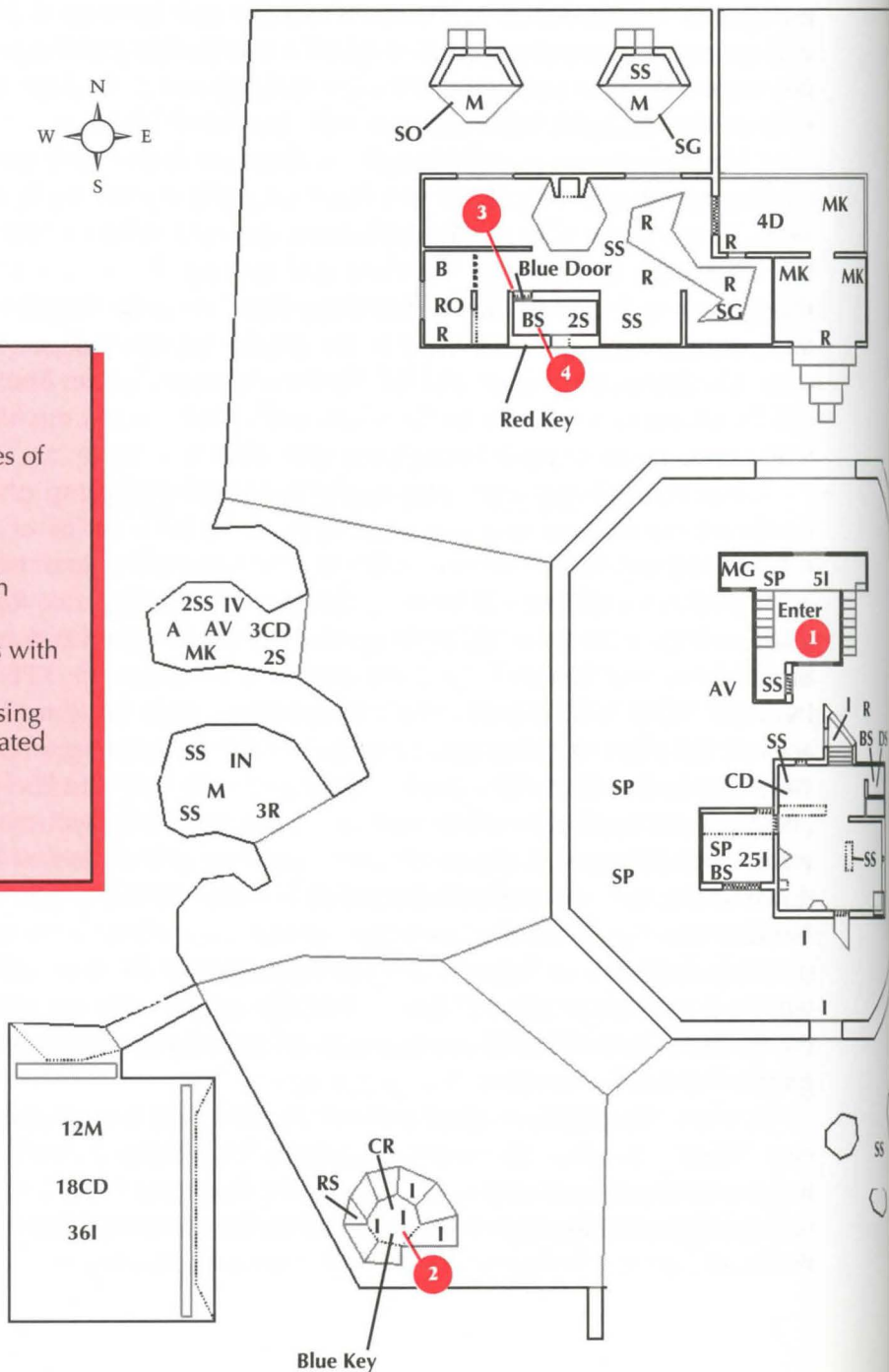
Activate the platform again and get on. As it lifts you up, face northeast. When you clear the walkway, blast a hole through any Imps that happen to be in front of you and run to the northeast corner where you will see the red door. Open the door and hit the switch behind it. Whew, this level's over.

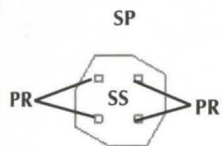
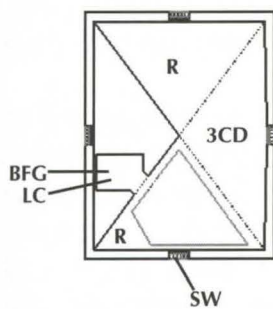
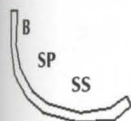
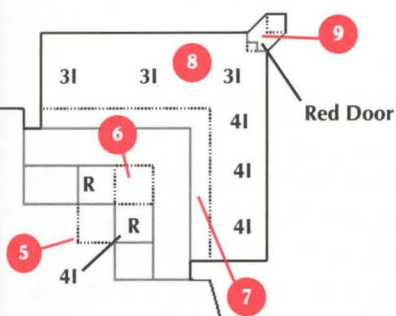
## MISSION 16: SUBURBS



## Waypoints

- 1 Start
- 2 Blue Key and 4 cases of rockets
- 3 Blue Door
- 4 Red Key
- 5 Platform lowers with spacebar
- 6 Lift platform, lowers with spacebar
- 7 Wall that lifts, releasing Imps when (6) activated from top
- 8 Red Door
- 9 Exit





SP

### The Bestiary

- AV** Arch-Vile
- CD** Cacodemon
- D** Demon
- I** Imp
- M** Mancubus
- R** Revenant
- S** Spectre

### Locations

- SD** secret door
- SW** switch
- T** transporter

### Special Items

- B** berserker pack
- IN** invisibility sphere
- IV** invulnerability sphere
- LC** large energy cell
- MK** medikit
- RS** radiation suit
- SO** soul sphere
- SP** stimpack

### Weapons & Ammo

- A** box of ammo
- BFG** BFG 9000
- BS** box of shells
- CR** case of rockets
- DS** combat shotgun (super shotgun)
- MG** machine gun (chain gun)
- RO** rocket
- PR** plasma rifle
- SG** shotgun
- SS** shotgun shells (4)

## **MISSION 17: TENEMENTS**

At the entrance you will be in an alcove with a walkway in front of you going north through a pool of toxic waste. There will be roughly 12 rounds of shotgun shells in the alcove with you. As you cross the walkway you will notice it is in the middle of a large room. You will also notice that high up on the north end of both the east and west walls doors will be rising, revealing bars constraining a group of malicious Imps, obviously plotting your imminent demise. Ignore them for now, but keep moving.

The walkway empties into a room with a door in the north wall. Two halls also lead off, one to the east and one to the west, and two sets of stairs lead up beside each hall. When you walk through the door, turn right and shoot the two Sergeants and the Former Human at the end of the hall. Turn back toward the room with the toxic waste. From the doorway, kill all of the Imps behind the two sets of bars—first one side, then the other. Turn west and go down the hallway.

At the end you will see a crooked walkway running from the end of the hall to an alcove in the east wall containing the red key, three medikits, and a box of shells. The walkway is about two stairs above a pool of toxic waste, so do this right. Line yourself up in the middle of the walkway facing the center of the end of the walkway. Run straight to the end and grab the key, then turn around and go back out. Do not touch the right-hand wall on the way to the walkway, or the door at the end of the hall you were in will close and temporarily trap you in this room. Hit the left side of the doorway as you go through. This will cause a door to drop down and temporarily seal the room.

Running down the walkway triggered secret doors that opened, releasing six Cacodemons. As soon as you get through the door, go up the stairs on the west side of the room and enter the red door at the top. When you go through, there will be five Spectres on your right. Mow them down and hit the switch in the southeast corner of the room. This room also contains medikits, green body armor, a box of shells, and three health bonuses. Scoop these up on the way back out.

When you get to the bottom of the stairs, go up the other set of stairs in front of you. This room will contain four helmets, eight shotgun shells, a

## Chapter 6 Intelligence Briefings

shotgun, and a medikit. Grab these and go to the southeast corner of the room. There will be a lift pad with a box of shells on it, and a switch on the wall. Activate the switch and ride the lift down. You will be in a small room with five Spectres and a berserker pack. Along the west wall is a walkway with a Hell Knight pacing back and forth on it. Kill all of the Demons, then grab the berserker pack. If you have to grab it before they are all dead, have no fear—there are three medikits on the walkway with the Knight.

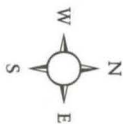
Follow the walkway to the end and activate the switch. This will open the section of wall to the east, revealing a lift. Ride it to the top. You will find yourself in a room with a barred wall to the west and Imp carcasses loitering the floor, provided you've done your part up until now, that is. Go to the south wall and activate the switch. Now go through the opening in the north wall. Hit the switch on your left, and the panel it is on will open. Below you is the room you were looking into when you started. Jump to the doorway in the north wall. The Cacodemons are likely to be loose by now, so move quickly.

When you land, go through the north doorway, and through the door in the north wall which is now open. You will be in a room with no roof that is flooded with toxic waste. There are four platforms raised about a foot above the sludge: the one you are on; one in the center, which has a pillar about 20 feet tall with a soul sphere on it; one in the center of the west wall with a blue door; and one in the center of the north wall with a yellow barricade in the doorway and a wooden column on the south side of it. There is also a stairway leading up from the center of the east wall.

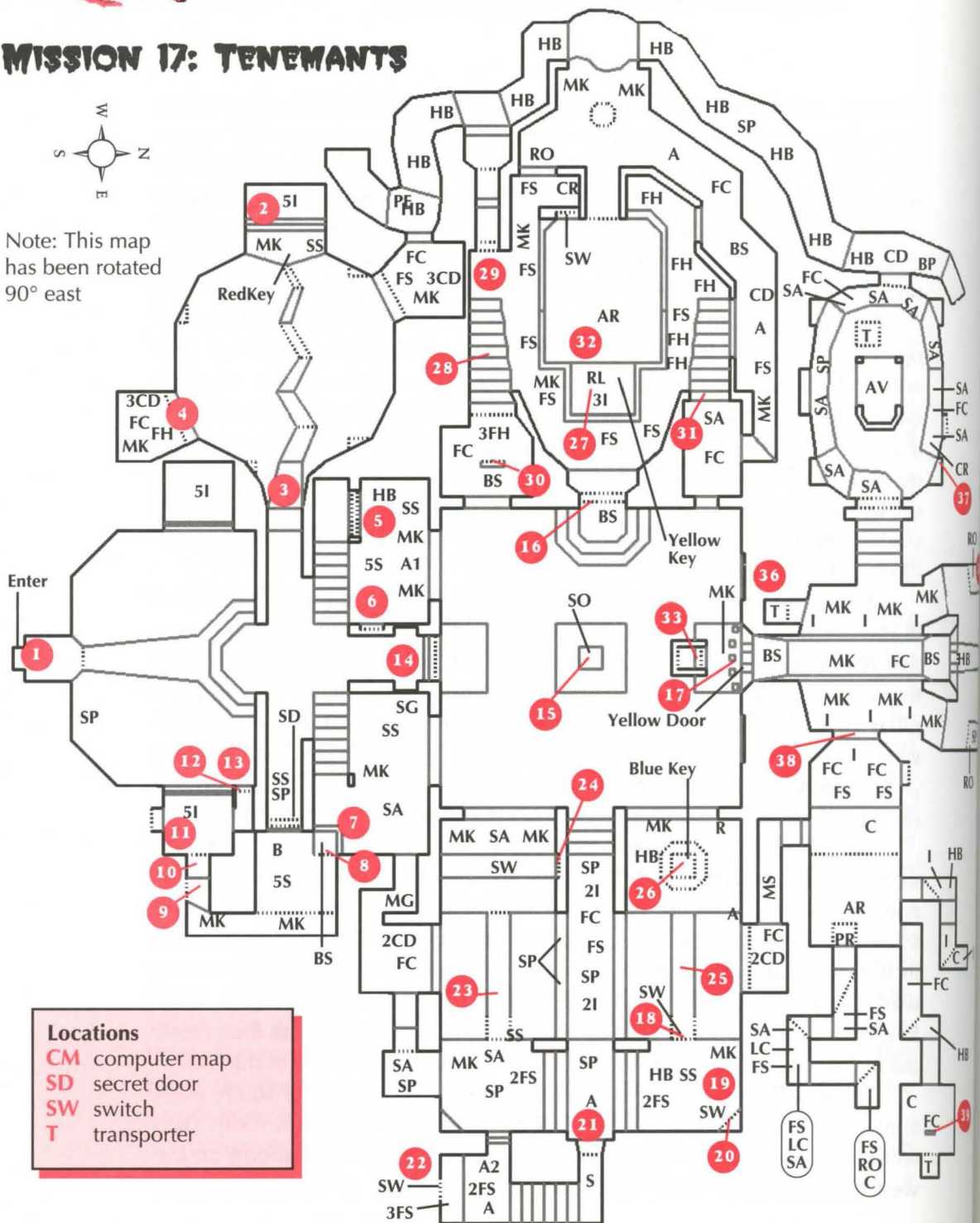
You will see a Cacodemon and four Imps. This would be a good time for the rocket launcher. Kill the Imps, then grab the green armor on the north side of the column. Now turn and face south. Time to take care of those pesky Cacodemons—make sure you kill all of them. Go up the stairs in the east wall. At the top you will see a hall running east with barred walls. Turn to face the north wall and slide to the east. You will see a Revenant on a platform on the other side of the wall. Shoot him, then move out of the way—repeat this till he's dead. Continue to the end of the hall.

There will be two rooms, one to the north and one to the south, each containing two Sergeants. Kill all four and go into the north room. You will be on a raised platform on the east end with another platform on the west end and toxic waste in between. Move to the center of the edge,

## MISSION 17: TENEMANTS



Note: This map has been rotated 90° east



## Locations

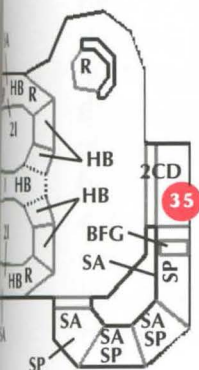
- CM computer map
- SD secret door
- SW switch
- T transporter

**The Bestiary**

- AR** Arachnotron
- AV** Arch-Vile
- CD** Cacodemon
- FH** Former Human
- FC** Former Human Commando
- FS** Former Human Sergeant
- I** Imp
- PE** Pain Elemental
- R** Revenant
- S** Spectre

**Special Items**

- A1** green armour
- A2** blue armour
- B** berserker pack
- C** energy cell
- HB** health bonus (vials)
- LC** large energy cell
- MK** medikit
- MS** megasphere
- RS** radiation suit
- SO** soul sphere
- SA** spiritual armour
- SP** stimpack

**Weapons & Ammo**

- A** box of ammo
- BFG** BFG 9000
- BP** backpack
- BS** box of shells
- CR** case of rockets
- MG** machine gun (chain gun)
- RO** rocket
- PR** plasma rifle
- RL** rocket launcher
- SG** shotgun
- SS** shotgun shells (4)

**Waypoints**

- 1 Start
- 2 Red Key
- 3 Hitting corner of north wall causes door to lower
- 4 Secret doors with Cacodemons triggered by movement on the walkway
- 5 Red Door
- 6 Switch reveals (7)
- 7 Lift pad
- 8 Switch lowers (7)
- 9 Switch opens (10)
- 10 Lift Secret door
- 11 Switch that opens (14)
- 12 Secret door
- 13 Position after jumping through (12)
- 14 Door opened by (11)
- 15 Soul sphere on top of tower
- 16 Blue Door
- 17 Yellow barricade
- 18 Switch lowers (19)
- 19 Platform
- 20 Switch raises (21)
- 21 Walkway
- 22 Switch raises floor of trench and (23)
- 23 Walkway
- 24 Switch
- 25 Walkway
- 26 Blue Key and goodies
- 27 Yellow key, behind it is switch which lowers (15)
- 28 Stairs, activates (29)
- 29 Secret door, behind which is soul sphere. Moving through the door raises (28)
- 30 Switch
- 31 Door opened by (30)
- 32 Lift platform
- 33 Yellow Door
- 34 Crossing this area opens (35)
- 35 Secret door with Cacodemons
- 36 Transporter to (15)
- 37 Switch lowers (38)
- 38 Platform
- 39 Exit

turn around, and drop into the toxic waste. There will be a switch in front of you that lowers the platform. Quickly get on and go to the northeast corner where you will see another switch. Activate it as you ride up. This will open a panel at the end of the hall between the two rooms. Quickly go through this before it closes, or you have to do the switch thing again.

In front of you will be a Spectre. Kill him. On the other side of the Spectre will be a barrel at the foot of a set of stairs running up to the south. Shoot the barrel to cause a chain reaction that will kill most of the Sergeants at the top of the stairs. Go up the stairs and finish off the few who are left. There will be a switch in the south wall. Activate it, grab the case of ammo and the blue armor, and exit through the opening in the west wall.

You will now be in the room on the other side of the hall from the one where you did the switch trick. This room is laid out the same, but you will see a walkway rising out of the toxic waste, connecting the platforms at each end. Cross the walkway, and you will see a trench running north/south dividing the platform on the west end. Jump into the trench on the north side. You will be standing in toxic waste—quickly activate the switch in the north wall and the floor will start to rise. Turn south and kill the Pain Elemental in the trench with you. As the floor of the trench reaches the top, a section near the top of the south wall will open. There is a commando standing there, and two Cacodemons will be loose. Kill all three and go back across the walkway after collecting the four helmets and one medikit on the platform.

At the end of the platform, turn north where you will see that a similar panel has opened in the room across the hall. Kill the two Cacodemons across the hall, as well as the commando. There will now be a walkway connecting the two platforms in this room. Cross it and grab the blue key, the medikit, and four health bonuses. Go back across the walkway and into the hall to your right. Go west and back down the stairs. Cross the pool of toxic waste and open the blue door. You will be facing east.

In front of you is a wall with three Imps on it, and the red key. A commando is stationed in front of the wall. On each side of the wall is a hall with several Former Humans and Sergeants. Open fire but don't go through the door. Use the wall that the door is in for cover. Once the way



## Chapter 6 Intelligence Briefings

is clear, enter the room and go down the hall on the right. Clear it and come back to the door.

Start down the left hall. Here you will find a medikit with a Sergeant beside it and a Former Human at the far end of the hall by another medikit. Kill them both. Along the left wall is a stairway starting at the east end and going up to the west toward you. Turn around and back up down the hall toward the foot of the stairs, aiming at the top. There will be three commandos, three Former Humans, and a box of shells. Go up the stairs, grab the goodies, and go back down the stairs.

As you descend the stairs, a panel in the wall at the bottom will open. Inside is a soul sphere. Behind it is a wall about four feet tall. On the other side is an invisibility sphere and a couple of health vials. You can't cross the wall, so grab the soul sphere and exit the alcove. The two halls you have already been down go around an arena like a pit, at the bottom of which is an Arachnotron and toxic waste. You will now see that a switch has appeared at the top of the stairs. Activate it and come back down. Move around the pit to the hall on the north side, and go up the stairs along the north wall. The switch you activated at the top of the last set opened the door at the top of this one. At the top will be a commando and 14 helmets. Grab the goods and go through the opening in the north wall.

This hall is dark—immediately turn west and follow the hall. Along the way you will find a medikit, a box of shells, and two boxes of ammo. This hall opens into a small room containing a Cacodemon, a commando, and two medikits. Along the west wall is a tunnel with water in it running north/south. Follow it to the north. Along the tunnel you will find nine health bonuses, a stimpack, and at the end, a Pain Elemental and backpack. Kill the Elemental, grab the goodies, and return to the previous room.

At the east side of the room is a short hall that opens over the west end of the pit containing the Arachnotron. You will see that the center of the east wall of the pit is different from the rest of the walls. Take a running jump into the pit and head for the east wall, avoiding the Arachnotron. The middle of the east wall will lower. On this platform will be the yellow key and a rocket launcher. Ride this platform up. If you miss it, there is a switch in the southwest corner of the pit that will lower it again. Grab the rocket launcher and the key, and jump off the platform to the east and go out the blue door.

Head northeast for the yellow barricade. There will be a commando and an Imp on the other side. Kill them, then turn facing south and enter the yellow door in the tower. Inside there will be a switch, and activating it will lower the barricade. Pass the barricade into the room to the north. There is a descending hallway between the east and west sides to the room. Go to the middle of this hallway, put your back against one side, and kill everything on the side you are facing. Repeat for the other side. Go to the north end of the hall. You will see that it leads onto a walkway, above a pool of toxic waste. After about 20 feet it splits and each side curves back toward one side of the room or the other, but stops short of touching it. On each end are two Imps and beside the left fork is a tower with a Revenant in it. Move in and out of the opening till you have killed the Imps and the Revenant, then move out and take the left fork. At the end, jump to the room. This will open a door in the wall on the north end of the chamber you were in, releasing two Cacodemons and a Pain Elemental. Turn and kill them. Go to the south end of the room and enter the transporter.

You will be on top of the tower with the soul sphere that you saw earlier. Jump off to the north, and reenter past the yellow barrier, repeating the steps to get to the area where the transporter was. After you land, grab the three medikits. Head up the stairs in the east wall. Open the door. You will be in an oval room with a tower in the center surrounded by toxic waste, and a walkway starting at the door and running around the room to a switch. On your right you will see a commando. Kill him and start down the walkway. You will now see a commando that was hidden by the tower—shoot him. This reveals an Arch-Vile inside the tower. Shoot him and pull back repeatedly, till he's dead.

Follow the walkway to the end and activate the switch, then go back to the door and down the stairs. Across from you will be a door that opened when you activated the last switch. Coming out of it are three Imps, two Sergeants, and two commandos. Kill them. Back up the stairs to the door and take a running jump toward the new door. Go through it, and in the north wall activate the switch, which lowers a platform on the east wall. Get on the platform, pick up the three energy cells, and ride it up. On the way up, grab your plasma rifle and face east.

## Chapter 6 Intelligence Briefings

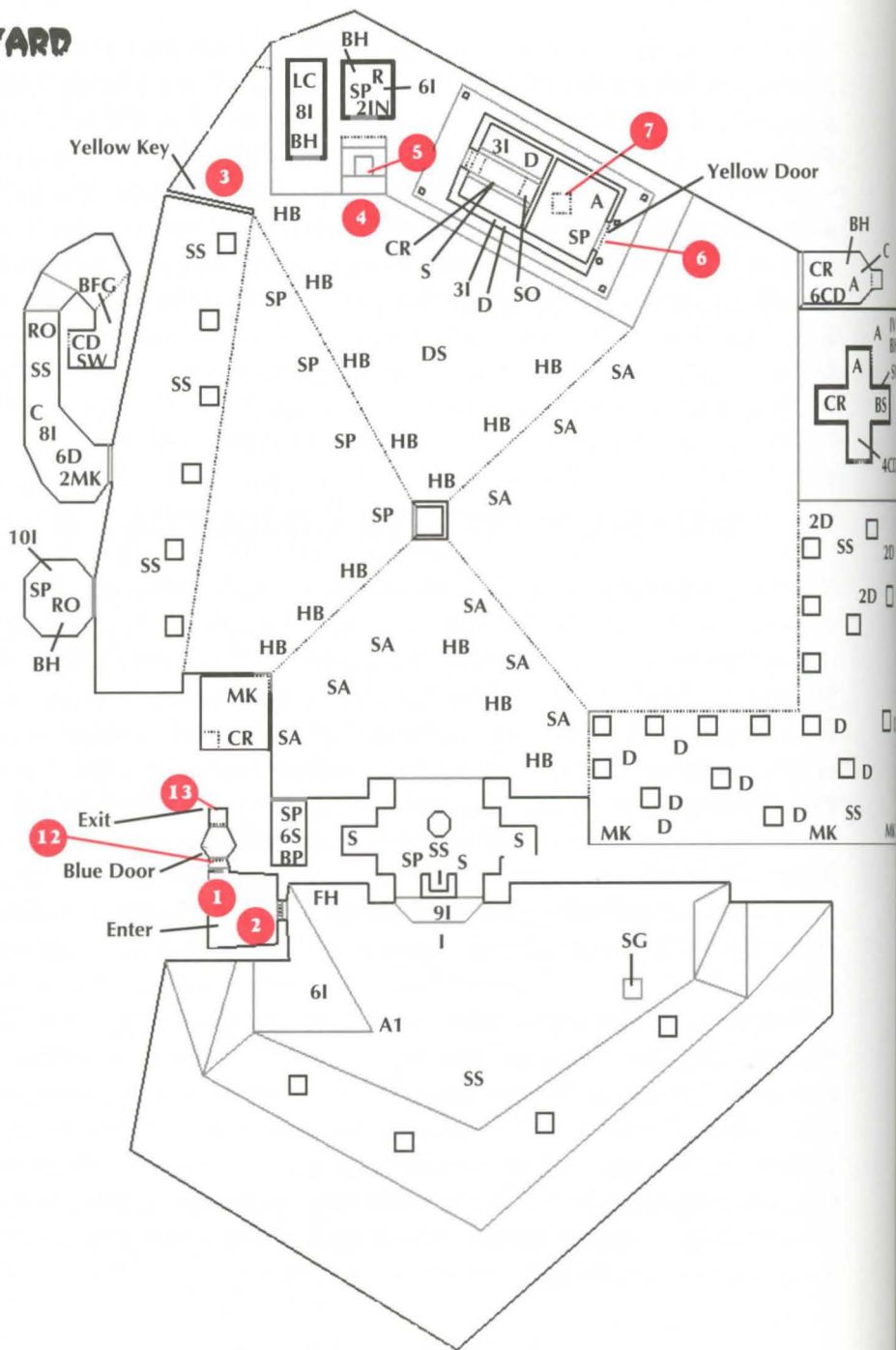
At the top there will be an Arachnotron in a room to the east. Kill him and snatch the plasma rifle against the east wall. This will trigger open a passage in the north wall with an Imp in it. Kill the Imp. Go to the end of the passage and return to the main room. You will now see a passage in the east wall with a Sergeant in it. Toast him, go to the end of the passage, and return to the main room. This will open a new section in the first passage. Go to the end of this section, which will open a new section of the second passage. Go through it, and this will open a new passage in the northeast corner of the main room. Go down the new passage. Go back to the second, then back to the third. At the end of the third, finally, is a small room with three commandos and the exit.

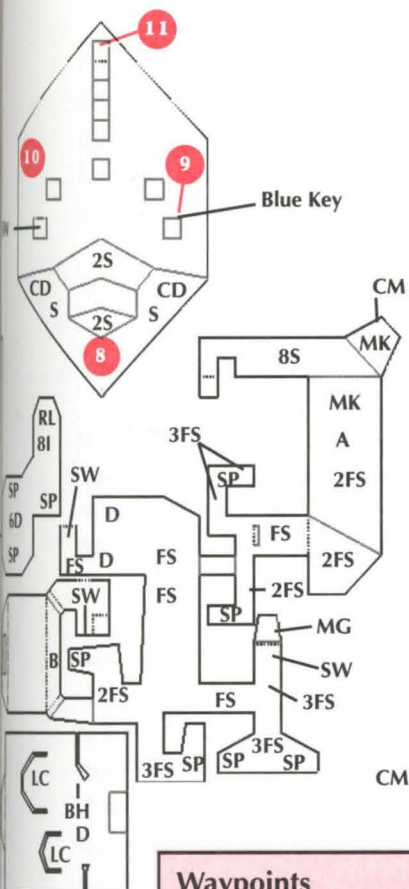
### MISSION 18: THE COURTYARD

First piece of advice: Haul! You do not walk on this level, you run. Shoot the door to the east, and it will open. Go through it. A passel of Imps present themselves for your shooting pleasure. Blow a hole through the Imps to get through the door in the north wall. There will be four health bonuses and four spirit armors, one line of each running from the center of the courtyard to the northwest, northeast, southwest, and southeast. Don't take the time to get them all, just grab what you can on the way. Go through this room into the courtyard and proceed directly to the northwest corner. Grab the yellow key. When you come out of the corner, go east and then up a stairway leading north. At the top turn east again. You will see a building. Enter it through the yellow door on the east end.

Go into the transporter, which will take you to a hexagonal building that is segregated from the rest of the level. Inside, you will see five columns. There will also be a friendly welcoming party of six Cacodemons. Use the BFG and keep moving. The floor will be littered with health bonuses, which should help. Go to the north side of the far right column and get the blue key. On the north side of the column on the far left is a switch. Activate it and go to the teleport that pops up in the north end of the room.

# MISSION 18: THE COURTYARD





### Waypoints

- 1 Start
- 2 Shoot door to open
- 3 Yellow key
- 4 Movement here opens (5)
- 5 Secret door
- 6 Yellow door
- 7 Transporter
- 8 Where (7) takes you
- 9 Blue key
- 10 Switch raises stairs to (11)
- 11 Transporter, takes you back to (8)
- 12 Blue door
- 13 Exit

### The Bestiary

- BH** Baron of Hell
- CD** Cacodemon
- D** Demon
- FH** Former Human
- FS** Former Human Sergeant
- I** Imp
- R** Revenant
- S** Spectre

### Locations

- CM** computer map
- SW** switch

### Special Items

- A1** green armour
- B** berserker pack
- C** energy cell
- HB** health bonus (vials)
- IN** invisibility sphere
- IV** invulnerability sphere
- LC** large energy cell
- MK** medikit
- SO** soul sphere
- SA** spiritual armour
- SP** stimpack

### Weapons & Ammo

- A** box of ammo
- BFG** BFG 9000
- BP** backpack
- BS** box of shells
- CR** case of rockets
- DS** combat shotgun (super shotgun)
- MG** machine gun (chain gun)
- RO** rocket
- RL** rocket launcher
- SG** shotgun
- SS** shotgun shells (4)

This takes you back to the previous room. Exit through the door on the east wall and head south through the courtyard. Again, grab all the health you can. Go back through the south exit that you came through earlier in the level. Turn right and go through the door to the west, and you will be in the same room you started the level in. Open the blue door in the northwest corner and exit.

### **MISSION 19: THE CITADEL**

You will be standing outside looking at a door to the north. Behind you is a small building. Turn around and move to the east side of this building. There is an Arachnotron moving toward you from the west. Use the building for cover and kill him. While you are shooting at the Arachnotron, the door you were facing will open and a Sergeant will come out. Dispatch him also. Once they are both dead, go through the door.

On the other side is a small room with two Sergeants in it. You will see an opening in the south end of the west wall and a door in the middle of the east wall. There is also a door in the north wall. Go through the opening in the west wall. Inside the door are two stimpacks. Around the corner to the right are seven Imps and 20 shotgun shells. Pick up the loot, exit this room and go through the door in the east wall. Inside you will find seven Imps, two stimpacks, four shotgun shells, and a switch in the southeast corner. Hit the switch and exit the room.

When you are back in the main room, go through the door in the north wall. In front of you a bridge leads across a stream to another door. On each side of the door, on the second floor, are windows with Imps behind them, so move quickly. Cross the bridge and open the door. Inside are two Lost Souls and a Cacodemon. Kill them from the doorway, then enter and grab the six helmets and the box of shells by the door. Watch out, the windows you saw beside the door outside have a matching pair in this room. The room you are in has a lower section, which you are on, and two sets of stairs, one along the east wall and one along the west leading to an upper level to the north. Move quickly up the stairs along the west wall. At the top is a door on your left—go through it.

You will be in a large room with two doors, one in the west end of

## Chapter 6 Intelligence Briefings

the south wall and one in the west end of the north wall. In the south end of the west wall is an opening about eight feet above the floor. There will be several Imps shooting at you through this opening. There will also be a switch in the center of the room, and a box of ammo to the east of the switch. Kill the Imps in the opening, grab the ammo, and hit the switch. This will open both doors. Go through the one in the south wall. You will be at the end of a hall running east, and at the east end is a door. Select your minigun and open the door. As soon as it goes up, open fire and kill the four Imps on the other side.

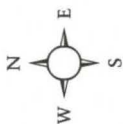
The hall continues east to a small room. In this room is a box of ammo and two switches. Activate the switch on the north wall. The wall will open to the left of the switch, revealing a transporter. Enter, and you will find yourself in a room that is empty except for 10 health bonus vials. You will see a doorway in the southeast corner. Move to the south wall facing the opening and you will see several Demons who have now seen you and are headed your way. Mow them down and collect the health bonuses.

When you exit the room you will see two hallways, one running east and one running south. Head east. There will be a small room at the beginning of this hall. It will appear that the hallway is inaccessible because it is raised. Move to the mouth of the hall and stand there. The section of floor you are standing on will lift you up to the hall. Move down the hallway until you come to another raised section. You will pass an opening on your right. On this raised section will be Demons. Kill all that you can see. Then return to the opening and go to the end.

Through this opening you can see that you are above a courtyard with a square building in the center. The building has a medikit at each of the four corners. In the south wall of the courtyard is an alcove on the second story with an Arachnotron and a Cacodemon—kill both. It is a long shot and you will have to do it quickly, so use rockets or the BFG. Return to the hall and go back to the west.

When you get back to the doorway of the room you transported into, take the hall running south. Along the way you will pick up a berserker pack. Oh, what a rush. From here on, you can shoot the bad guys, but you can also just duke it out. A little more dicey perhaps, but one helluva lot of fun! You will also pass an opening on your right with a box of ammo in

## MISSION 19: THE CITADEL



Note: This map has been rotated 90° west

### The Bestiary

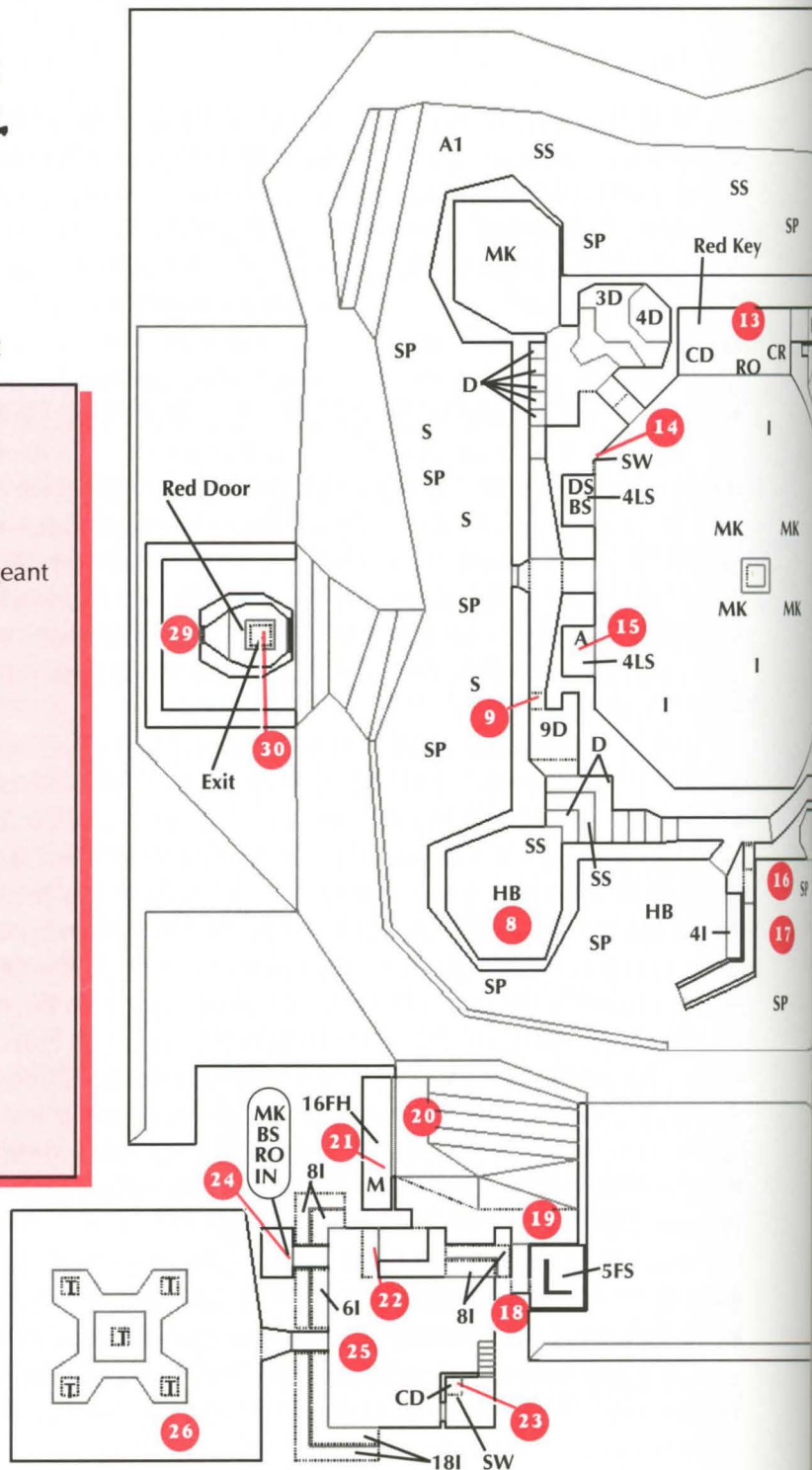
- AR** Arachnotron
- CD** Cacodemon
- CY** Cyberdemon
- D** Demon
- FS** Former Human Sergeant
- I** Imp
- LS** Lost Soul
- S** Spectre

### Locations

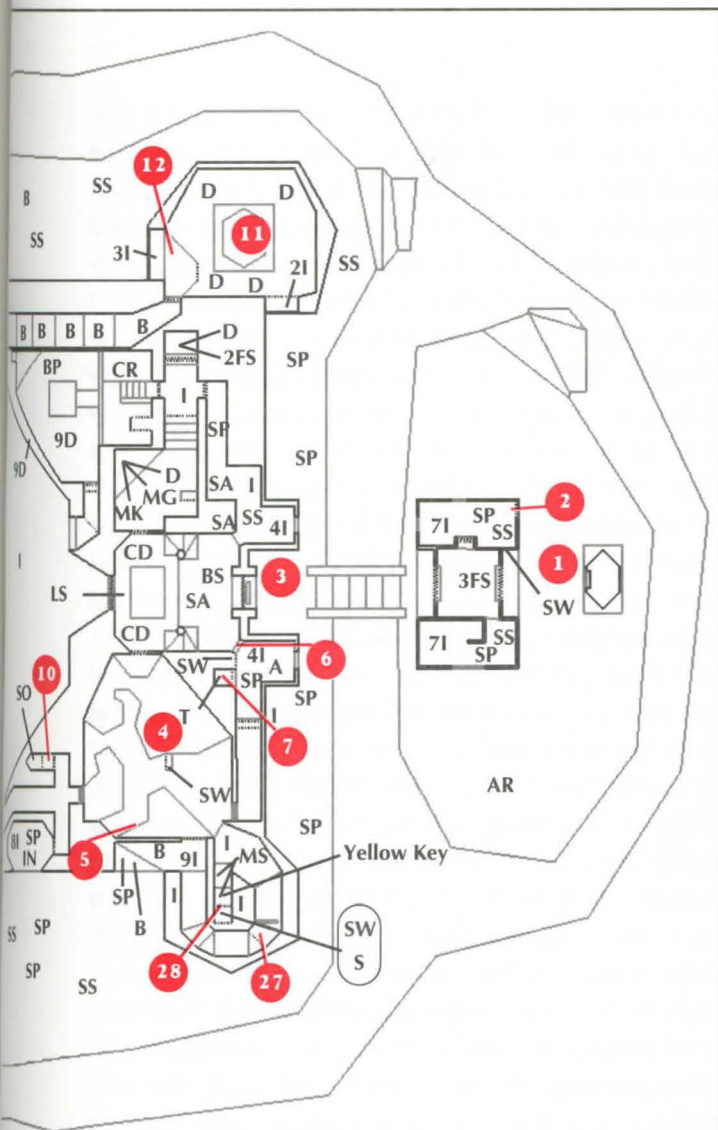
- SW** switch
- T** transporter

### Special Items

- A1** green armour
- B** berserker pack
- HB** health bonus (vials)
- IN** invisibility sphere
- MK** medikit
- MS** megasphere
- SO** soul sphere
- SA** spiritual armour
- SP** stimpack







### Waypoints

- 1 Start
- 2 Switch lowers (3)
- 3 Barricade
- 4 Switch opens (5)
- 5 Locked door
- 6 Switch opens secret door, behind which is (7)
- 7 Transporter
- 8 Where (7) takes you
- 9 Lift platform
- 10 Secret Transporter
- 11 Where (10) takes you
- 12 Platform raises when all Imps are dead
- 13 Red Key and rockets
- 14 Switch lowers (15)
- 15 Platform with goodies
- 16 Secret door
- 17 Lift
- 18 Switch opens (19)
- 19 Locked door
- 20 Section of wall lowers when you exit (19)
- 21 Computer area map
- 22 Crushing ceiling
- 23 Switch opens (24) & (25)
- 24 Cache of goodies
- 25 Secret door
- 26 Transporter
- 27 Where (26) takes you
- 28 Yellow Key
- 29 Door requiring Red Key plus either the Blue or Yellow keys
- 30 Exit

### Weapons & Ammo

- |  |                                   |
|--|-----------------------------------|
| <b>A</b> box of ammo                     | <b>MG</b> machine gun (chain gun) |
| <b>BP</b> backpack                       | <b>RO</b> rocket                  |
| <b>BS</b> box of shells                  | <b>SS</b> shotgun shells (4)      |
| <b>CR</b> case of rockets                |                                   |
| <b>DS</b> combat shotgun (super shotgun) |                                   |

it. Grab the ammo and continue south. At the end of the hall is a door that won't open, and two short halls. One hall goes east and one west—take the hall to the east and open the door at the end. Inside you will see a soul sphere. You won't get it, but what you will get is transported onto a raised platform in the middle of the room. You will be looking at a barred window in the north wall with three Imps behind it. Kill them and turn toward the east wall, where you will see another barred opening with two more Imps behind it. Kill them also. When you transported in, you probably noticed that there was a door in the north end of the east wall at the same height as the platform you are on. When you have killed the last Imp, a platform will rise from the floor to the bottom of the door. Jump to this platform. Don't fall—there are four Demons on the floor below.

Open the door and follow the hall to the north. At the end you will see a Cacodemon in an alcove that opens onto the courtyard. This is the same alcove where you killed the Cacodemon and Arachnotron. This alcove also contains the red key, two individual rockets, and a case of rockets. You will also see two Cacodemons and six Lost Souls heading toward you from alcoves in the north wall of the courtyard. Grab the key and the rockets and open fire on the bad guys. When they are dead, jump down into the courtyard and head for the building in the center. Three more Lost Souls will come at you from the alcoves in the north wall. And a door in the south wall of the courtyard will open and two Imps will enter from there. After they are dead, grab the medikits, move to the north wall, and hit the switch on the east end.

This will lower the two platforms in the north wall. One will have a supershotgun and a box of shells and the other will have two boxes of ammo. Grab this stuff and go through the door in the south wall. You will be back on the upper level of the very first room you entered. Go through the door in the southeast corner again. Follow the hall down to the transporter and go in again. You will again be in the room where you got all the health vials. Exit the room and take the hall to the south.

As soon as you pass the opening on your right, where you picked up the ammo before, you will see three vertical metal stripes in the west wall. Move against the wall between the first two and hit **[Spacebar]**. This section of wall will lift, revealing a short hall. Move down the hall, picking up the green armor, to the end. Hit **[Spacebar]** again, and another section of hall

## Chapter 6 Intelligence Briefings

will lower. Step on to it, and it will rise, revealing even more hall (remember this, you will be doing it again). Follow the hall till it turns northwest. At this point you will be able to see outside. The end of the tunnel is open and one story above the ground. Run to the end and jump. You must clear the walkway around this building and its perimeter wall.

You will land in the moat that surrounds the building and be facing a smaller building with a wide stairway leading up to the front. Go up the stairs, and you will see two doorways in the east wall. Go through the one on the left. Watch your back—Imps are firing at you from the building you just left. Inside the doorway is a short hall running west with a door at the end of the south wall and a switch across from it on the north. Hitting the switch will open the door. The door opens into a small room with a wall in front of you running about eight feet to the south. Between you and the wall is a Sergeant, and heading around the wall from the north end is another. Kill both of them and head around the wall to the east.

At the end of the wall you will be able to see the rest of the room, which contains three Sergeants, one rocket, and a case of ammo. Waste these guys and collect the loot. Now head back out of the room and back down the hall. At the opening of the hall you will see that a section of wall on the north side of the stairway has opened, releasing 16 Former Humans. Take these guys out and go to the opening they came out of. In the west end of this opening you will find a computerized area map. Pick it up and go back up the stairs and enter the doorway on the right. Once through the doorway you will be in a short corridor that runs north. This corridor opens into another going west. Be careful, at the end of the corridor you are in is a large thick section of the ceiling going up and down. If you get caught under it, you will become a Marine crêpe.

Time it right and run under it. Keep running because this corridor leads into a room two stories high with alcoves along the walls, and the second story is filled with Imps. In the southwest corner of this room is a stairway leading up to a small room. Head to it since this is your only cover. If you have enough cells left to fire your BFG into the room, do so as soon as you reach the top of the stairs. If not, go through the door, turn to face north east, and open up on the Cacodemon sitting on the switch box there. Activate the switch. This will have two effects: It will open portions behind the Imps in the alcoves, and it will open two doorways in the room below.

Now it is time to make Imp-burger. Open fire on the Imps in the alcoves. The rocket launcher does a good job. Once you've gotten all of them, go back down the stairs, where you will see the two new doorways in the north wall. Go through the doorway into a small room that contains an invulnerability sphere, two rockets, two medikits, and a box of shells. Collect the goodies and exit the room. Now go through the other new opening.

You will be in a short hall that opens above a large room with water in it. In the center of the room is a platform with five teleporters on it: one in the center and one in each corner. Take the transporter in the southeast corner. You will now be in a winding stairway going up. Start climbing. You will run into a barricade that will lower when you get to it. Get ready—on the other side is an Imp. Kill him and move on. At the top of the stairs is a small room with two Spectres in it. After killing them, turn back toward the stairway and kill the Imp coming up. In the northeast corner of this room is a small hallway with the yellow key and a switch in it. Grab the key, hit the switch, and head back out of the hall.

In the northeast corner of this room is an opening that drops back into the first room you entered. Go through the opening and drop into the room. Go back through the door in the southwest corner and retrace the path you used to get to the room with the five teleporters, but instead of jumping across the moat, drop to the ground around the building and haul butt north.

At the corner of the building you will see a building to the northeast. Head for that. The front of the other building is open and through it you can see a room. Go into the building to the north side of the room. There will be a barred opening requiring the red key and either the blue or yellow key, which you have, to open enough of it for you to pass. Cross over the pool of toxic waste in the center and you are done.

## **MISSION 20: GOTCHA!**

You are facing north, looking at the back of a Sergeant who is facing a door. Kill him and turn around. To the south you will see a tower rising out of a lake of toxic waste. In the tower is a window, and you will see an

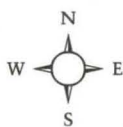
## Chapter 6 Intelligence Briefings

Imp and a Sergeant pacing in front of it. Kill both of them, then jump off the platform you are standing on toward the tower. When you land, a walkway surrounding the tower will start to rise, with you on it. Follow the walkway to the south side of the tower and hit the switch in the wall. The door will lower. Stand on it facing northwest. As it rises you will see a platform near the roof with a commando on it. Kill him and jump to the platform. Collect the loot he was guarding: two health vials, two medikits, green armor, and stuff on the floor below. Exit the tower and go back to where you started.

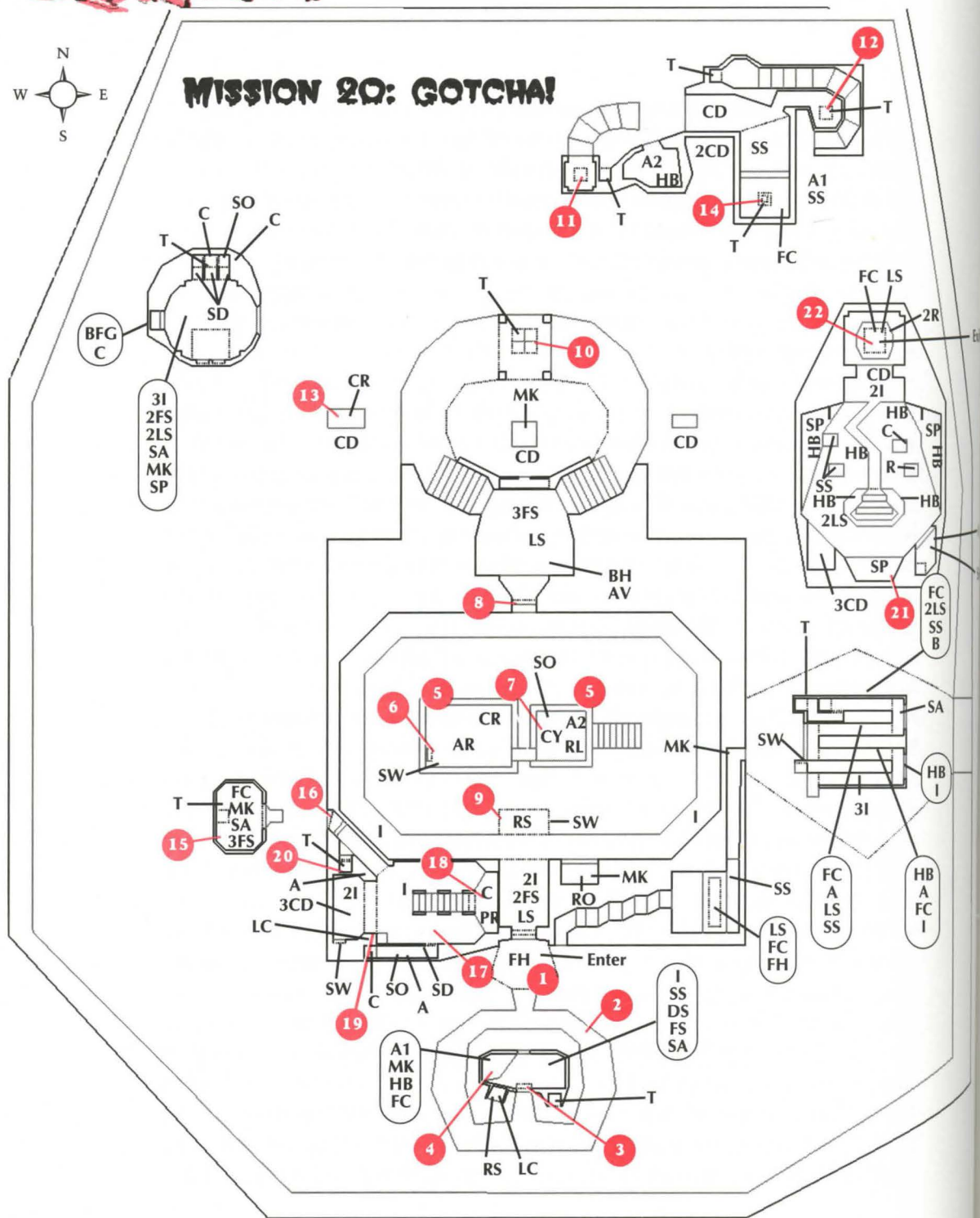
Open the door and start firing to kill the commando, Sergeant, and two Imps on the other side. There is a wide hallway in front of you going north. Stay where you are until two Imps enter the hall from the opening. Kill them, then go to the end of the hall. This opens into a large oval room in the middle of which is a large platform with two towers on it. You will be standing on a walkway that goes around the walls of the room. In front of you is a lift that will take you down to the floor one story below you. You will notice that the two towers are lowering into the platform. Move to the southwest corner of the walkway. As the towers lower you will see a Spider Mastermind on the west one and a Cyberdemon on the east.

As the platform lowers you will see a section of wall emerge on the west tower. Place yourself so that it is between you and the Spider Mastermind, while exposing as little of yourself as possible to the Cyberdemon. The two will begin to fight. Your job is to take out whichever one lives. Your best tactic for this is to jump down to the floor and stay close to the walls of the center platform. Move out, take a shot, and return to cover. Repeat till the monster is dead.

Next, move to the north side of the platform. In the center is an alcove containing a soul sphere. Grab it and head to the east end where you will find a set of stairs. Go up them and head for the section of wall you saw on the west end. Hit the switch you will find here. This opens the door on the north side of the walkway. Through this door you will be able to see a Baron of Hell, a Lost Soul, and an Arch-Vile. Send some heavy fire their way till they are all dead. Now jump to the floor and go back to the lift on the south side. It will lift you back up to the walkway. Walk around the walkway to the door in the north wall. Through this is a



# MISSION 20: GOTCHA!



### The Bestiary

- AR** Arachnotron
- CD** Cacodemon
- FH** Former Human
- FC** Former Human Commando
- FS** Former Human Sergeant
- I** Imp
- LS** Lost Soul
- R** Revenant

### Locations

- SD** secret door
- SW** switch
- T** transporter

### Special Items

- A1** green armour
- A2** blue armour
- B** berserker pack
- C** energy cell
- HB** health bonus (vials)
- MK** medikit
- RS** radiation suit
- SO** soul sphere
- SA** spiritual armour
- SP** stimpack

### Weapons & Ammo

- A** box of ammo
- BFG** BFG 9000
- CR** case of rockets
- DS** combat shotgun  
(super shotgun)
- PR** plasma rifle
- RO** rocket
- SG** shotgun
- SS** shotgun shells (4)

### Waypoints

- 1** Start
- 2** Walkway which raises when you jump to it
- 3** Door/Lift platform
- 4** Cache of goodies
- 5** Platform which lowers with Cyberdemon and Spider Mastermind
- 6** Switch on small section of wall opens (8)
- 7** Soul sphere
- 8** Locked door
- 9** Lift platform
- 10** Transporter
- 11** Where (10) takes you, also a Megasphere here
- 12** Transporter
- 13** Where (12) takes you
- 14** Transporter
- 15** Where (14) takes you
- 16** Secret door
- 17** Secret door
- 18** Plasma rifle and cell, picking up triggers (19)
- 19** Secret door with lots of monsters behind it
- 20** Transporter
- 21** Where (20) takes you
- 22** Exit

room containing four cases of rockets and three Sergeants, who may or may not have been killed along with the others. Collect the rockets.

There will be two doors leading out of this room, one in each end of the north wall. Go down the right-hand one. You will be on a descending stairway leading to a walkway. The walkway forms a U connecting to the set of stairs below the other door. On your right you will see a Cacodemon. Back up the stairs, firing as you go. When he is dead, go back down the stairs and there will be a Pain Elemental on your left. Repeat the previous procedure and go back down the stairs. Follow the walkway around to the transporter in the middle. Get on, and you will find yourself in a small room with a descending stairway coming out of it.

Take the stairway, and you will be outside. It winds to the right. You will see an alcove on the wall to your right with Cacodemon in it. In front of you the stairway ends, and across from it is an opening with another Pain Elemental in it. Kill both of these guys and jump to the opening where the Elemental was. This hall leads to a room with eight shotgun shells and green armor. As you move to grab these goodies, the wall behind them will rise revealing four commandos and a transporter. Mow down the commandos. To the northeast is an opening—go through this into the hall. Grab the two cases of rockets by the transporter at the end of the hallway and then enter the transporter.

You will be deposited on top of a tower. To the east and down about 30 feet you can see the U-shaped walkway with the transporter on it. Grab the megasphere in front of you and jump to the walkway. Go back to the transporter and follow the route you took to get to the room where the four commandos were. This time you take the transporter in the room the commandos were in. You will materialize in a lift shaft going down. When you reach the bottom, you will be in a small room. Three Sergeants and a commando will be firing at you. Wipe them out. There will be four helmets and a medikit here—pick up the goodies.

In the east wall is an opening. Move out to the ledge, and a section of wall across from you will lower. Run due east and jump through the opening. You will be in a hallway. Follow the hall to the end. It opens into a room with a stairway in the center going up to the east. Kill the Imp on the stairs. Move to the south wall. In the middle of this wall will be a secret door, behind which is a case of ammo and a soul sphere. Grab



## Chapter 6 Intelligence Briefings

these and go up the stairs. At the top there is a platform with a plasma rifle and a cell. When you grab these, the west wall of the room will open, releasing several bad guys. Quickly jump off the platform as soon as you get the cell, and exit the room through the hall you came in by. Near the end you will see a transporter that appeared when you went up the stairs—enter it.

You will be in an alcove in the south end of a long room running north/south. In front of you, also running north/south, is a stairway leading up to a crooked hallway. You will immediately be set upon by three Lost Souls, a Cacodemon, and two Imps. Get your plasma rifle ready and charge up the stairs, down the walkway, and jump in the hole at the end. Don't bother to shoot anything that is not obstructing your path on the way out.

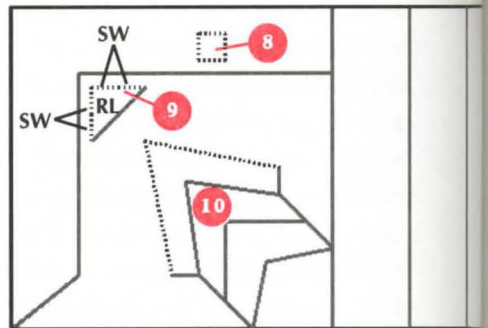
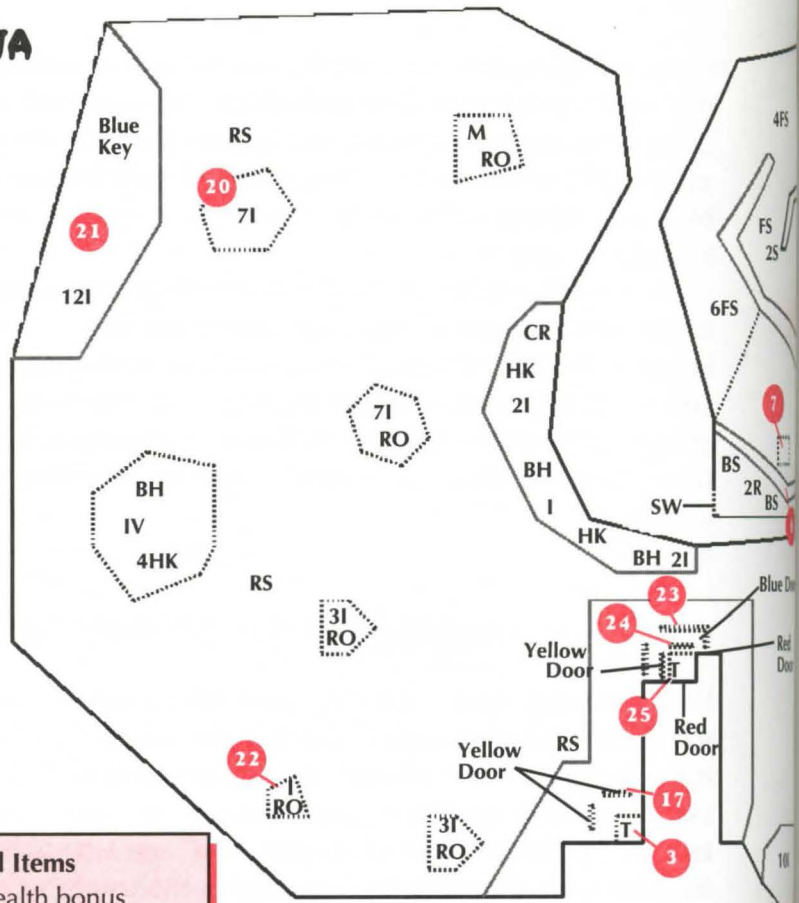
### MISSION 21: NIRVANA

You are facing north, standing on a large platform in the middle of a room that is slightly raised. On this platform are 12 health bonuses, a supershotgun, and 20 medikits. In front of you three Imps are facing away from you. In the northeast part of the room are two transporters. Kill the Imps and pick up any medikits you need. Enter the transporter closest to the west wall. You will be deposited in the southeast corner of a huge room.

You will be standing on a platform below which you can see that the floor is covered in toxic waste. You will be blocked by two yellow panels. Scattered around the floor are several towers whose tops are at the same level as the platform you are on. On these towers are Imps, Barons of Hell, and a Mancubus. From the spaces around the yellow barricades, open fire on the bad guys. When you see incoming fire, step back on the transporter, and you will be back in the room with the medikits. Wait a few seconds and go back. Repeat until you have killed as many as possible—usually all but the Mancubus on the north end. Transport back to the room with the medikits and hop on the other transporter.

You will materialize outside. Stand in the middle of a U-shaped wall facing south. You will be able to see that there is another wall outside this

# MISSION 21: NIRVANA



### The Bestiary

- BH** Baron of Hell
- FC** Former Human Commando
- FS** Former Human Sergeant
- HK** Hell Knight
- I** Imp
- M** Mancubus
- PE** Pain Elemental
- R** Revenant
- S** Spectre

### Locations

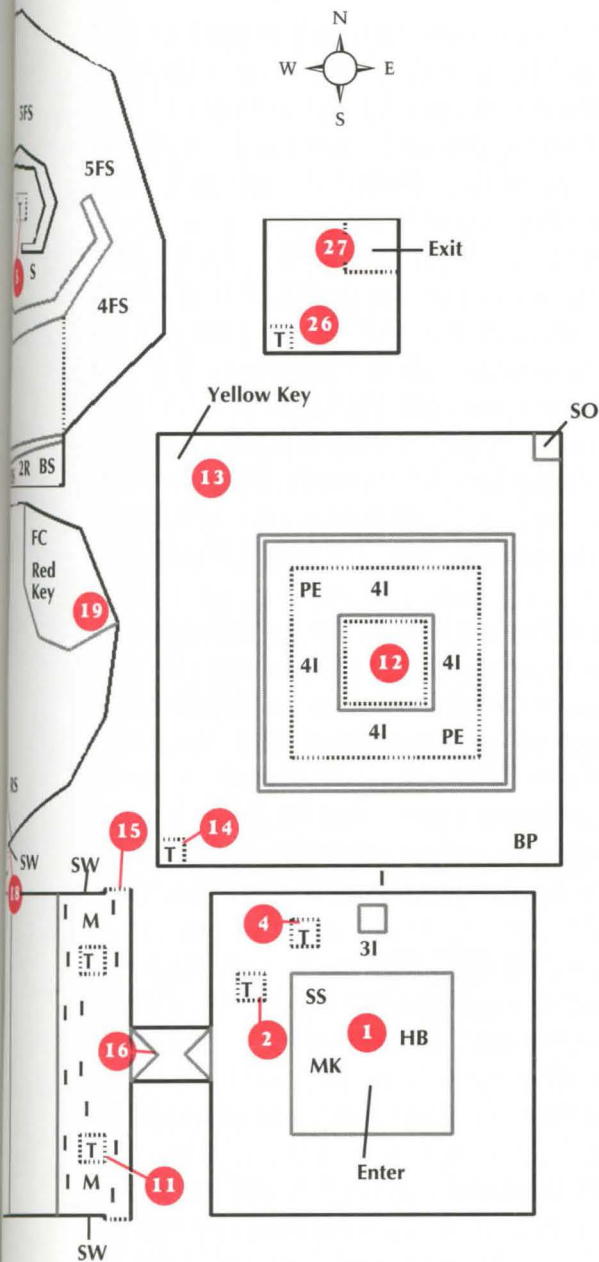
- SW** switch
- T** transporter

### Special Items

- HB** health bonus (vials)
- IV** invulnerability sphere
- MK** medikit
- RS** radiation suit

### Weapons & Ammo

- BP** backpack
- BS** box of shells
- CR** case of rockets
- RO** rocket
- PR** plasma rifle
- RL** rocket launcher
- SS** shotgun shells (4)



## Waypoints

- 1 Start
- 2 Transporter
- 3 Where (2) takes you
- 4 Transporter
- 5 Where (4) takes you
- 6 Secret door opens on approach, multiple enemies emerge
- 7 Transporter
- 8 Where (7) takes you
- 9 Small platform with 4 switches, hit all to raise (10)
- 10 Secret stairway
- 11 Transporter
- 12 Where (11) takes you
- 13 Yellow Key
- 14 Transporter takes you back to (11)
- 15 Switch opens (16)
- 16 Secret door
- 17 Yellow barricade
- 18 Switch lowers platform with (19) on it
- 19 Red Key
- 20 Lift platform
- 21 Blue Key
- 22 Lift platform
- 23 Blue barricade
- 24 Yellow barricade
- 25 Transporter
- 26 Where (25) takes you
- 27 Exit

one. Go to the opening and turn west. Here you will encounter two Spectres and several Sergeants. Kill them and follow the outside wall. This wall forms a U also, around the first opening to the north. Follow this to the opening, go around the end of the wall on your left, and head south. There will be another wall around this entire area—follow it. Blast anything that gets in your way and jump on the transporter.

You will now be in the west end of a large room with a divider running north/south in the middle. In front of you is a triangular platform with two switches on the north side, and two on the west side. Flip all four. This will cause sections of the floor to rise and form steps. The one closest to you will be too high, so run up to it and hit **[Spacebar]**. This section will lower. Get on and ride it up. Follow the stairway over the room divider. On the other side you will see two Mancubuses and nine Imps standing around two transporters; one in the northeast corner and one in the southeast corner. Beside each transporter is a switch. Kill these guys, and activate both switches.

The middle of the east wall will open, which leads back into the room with the medikits. Go get what you need, then come back and take the transporter in the southeast corner. You will now be in a small room. Be careful, some of the Imps you were just shooting at may have gone through the transporter to wait for you. After you have secured the room, grab your plasma rifle, face the northwest corner, and hit **[Spacebar]**. The wall will lower and you will see that you are surrounded by 14 Imps and two Pain Elementals. There will be another wall around them. Blast your way through, still facing northwest.

When you reach the next wall, hit **[Spacebar]** again. This wall will lower, and in the northwest corner you will see the yellow key. Grab it and head east along the wall. In the northeast corner you will see a megasphere on a raised platform. Ignore it—to stop is to die. Turn and follow the wall south, grab the backpack in the corner, and head for the transporter in the southeast corner.

You will be standing on the transporter you used to get to the last room. Go through the doorway in the east wall and grab what medikits you need, then take the transporter by the east wall. You will again be behind the yellow barricades. Open the one to the north and follow the walkway. You will come to a corner leading east. Here you will find two

## Chapter 6 Intelligence Briefings

blue barricades inside of which are two red ones. When you go around the corner you will see that the walkway goes around the blue barriers and turns south. Across from this corner to the east is a platform, on top of which are six commandos and the red key. Wipe them out, then go around the corner. The walkway ends about 40 feet ahead. Beside the end of it is a platform with 11 Imps and a switch. Kill these guys and jump to the platform with the red key on it. It won't stay down long so you have to move fast. Hit the switch and drop off the platform beside it.

You should land on a rad suit. Now run to the platform with the key. Get it, as well as the dead commandos' miniguns. Jump off the platform and head west. When you pass the wall where the blue barricade is, head northwest. If the Mancubus on the tower in the northeast corner is still alive, kill him now. In the northwest corner is a platform with a tower in front of it. Go to the tower and press **[Spacebar]**. The tower will lower. Ride it back up and jump to the platform. Grab the blue key and jump back off. Grab the rad suit at the base of the platform and head south.

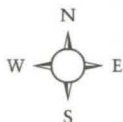
In the southeast corner is a tower. Hit **[Spacebar]** and it will lower. Ride it up and jump to the walkway. Go to the blue barricade, open it and the red one, and get on the transporter. This will take you to an empty room with a hole in the northeast corner—drop into the hole to finish the level.

## MISSION 22: THE CATACOMBS

As you enter this level, you will find yourself in a room lined with torches and columns. Go to the south wall and snipe between the torches until you kill the four Former Human commandos in this room. Go to the center torch on the south wall and press **[Spacebar]**. This trips a switch. Go to the southwest corner of the room. A platform will have lowered. Follow it into the room on the other side of the south wall and collect all the chainguns from your recent kills. You will see a teleporter on the east end of this room. Take it, and you will be delivered to a raised platform above a pit of toxic waste.

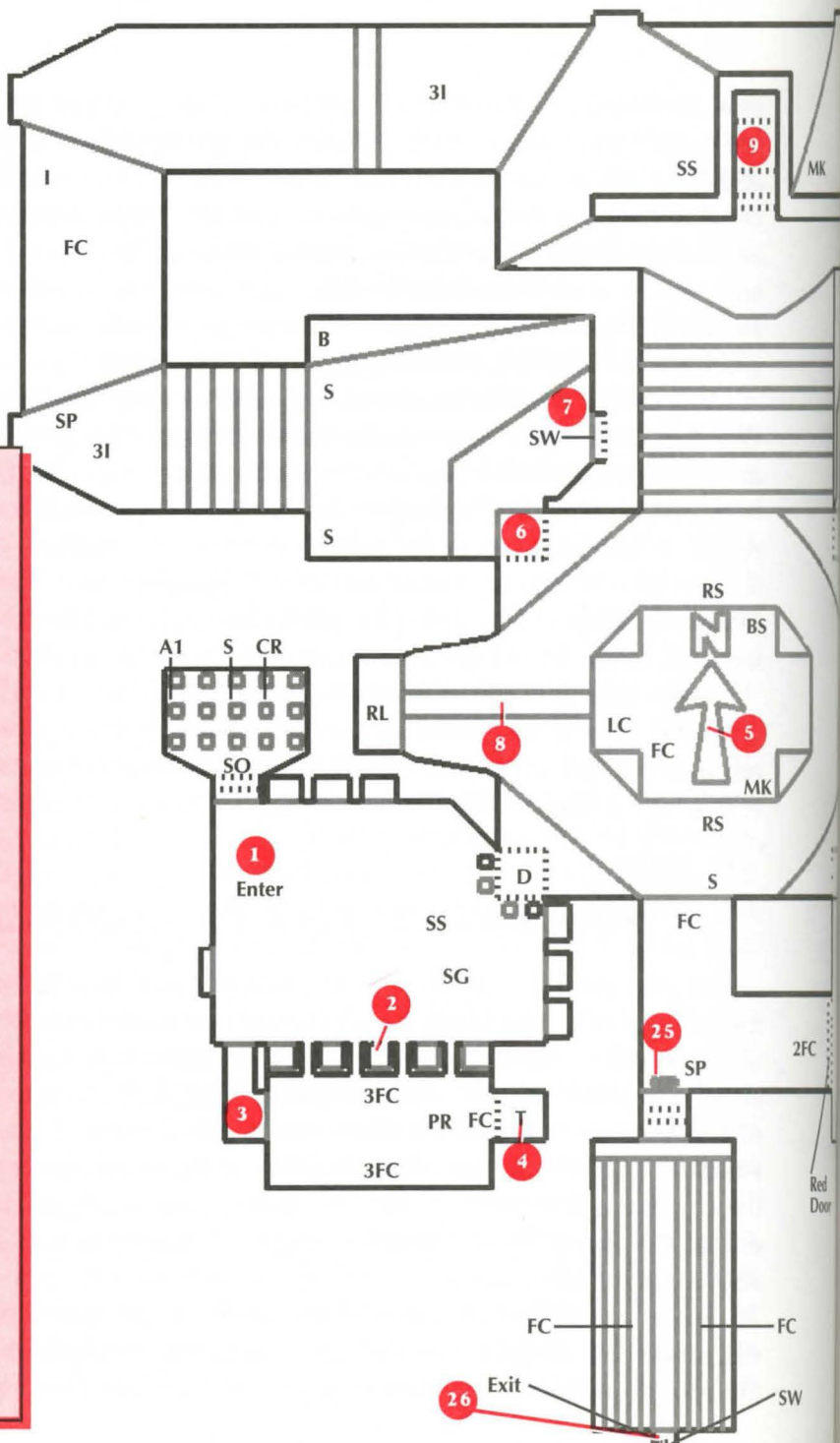
There are alcoves in each of the cardinal directions: north, south, east, and west. To get to any of them, you can go to any of the corners of the room—northeast, southeast, northwest, and southwest—by going

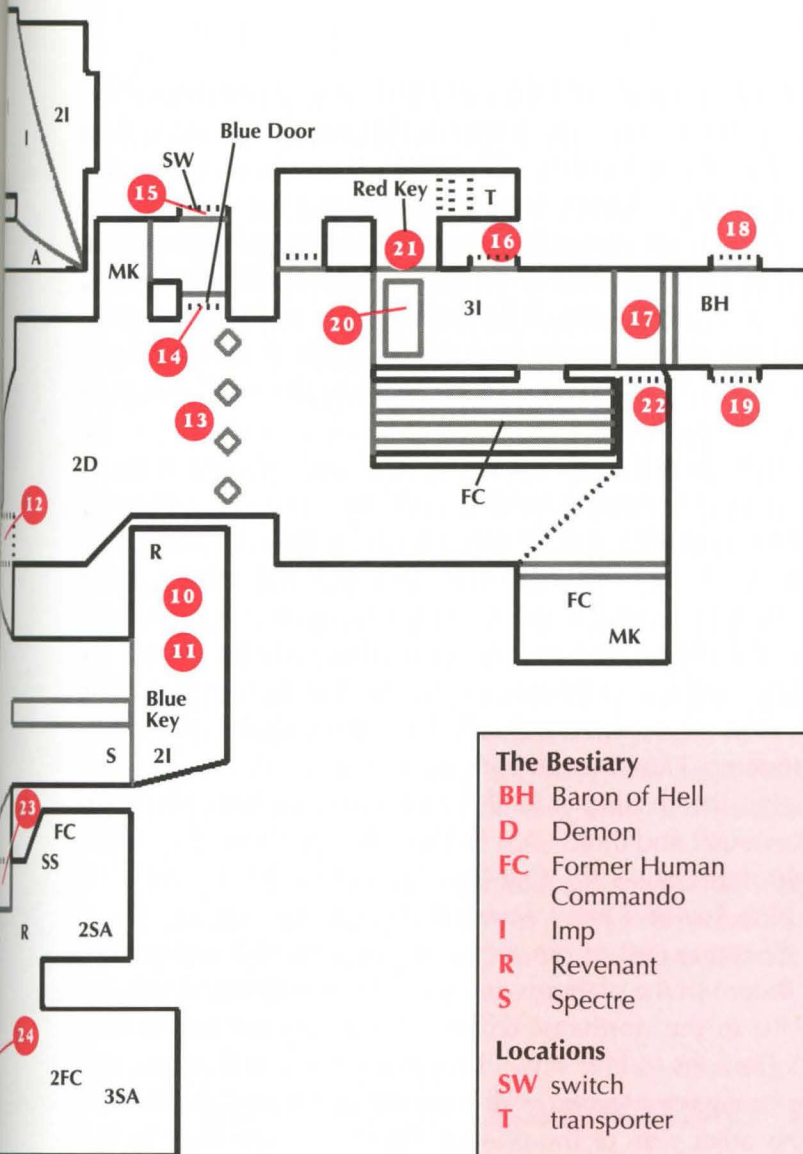
## MISSION 22: THE CATACOMBS



### Waypoints

- 1 Start
- 2 Switch activates (3)
- 3 Platform (lowers)
- 4 Transporter
- 5 Where (4) takes you
- 6 Lift platform
- 7 Switch raises (8)
- 8 Walkway
- 9 Transporter
- 10 Where (9) takes you
- 11 Blue Key
- 12 Lift platform
- 13 Barricade
- 14 Blue Door
- 15 Switch raises (13)
- 16 Switch opens (17)
- 17 Locked door
- 18 Switch also opens (17)
- 19 Switch lowers (20)
- 20 Platform
- 21 Red Key
- 22 Switch raises (13)
- 23 Lift platform
- 24 Red Door
- 25 Exit Door
- 26 Exit





### The Bestiary

- BH** Baron of Hell  
**D** Demon  
**FC** Former Human  
 Commando  
**I** Imp  
**R** Revenant  
**S** Spectre

### Locations

- SW** switch  
**T** transporter

### Special Items

- A1** green armour  
**B** berserker pack

- LC** large energy cell  
**MK** medikit  
**RS** radiation suit  
**SO** soul sphere  
**SA** spiritual armour  
**SP** stimpack

### Weapons & Ammo

- A** box of ammo  
**BS** box of shells  
**CR** case of rockets  
**PR** plasma rifle  
**RL** rocket launcher  
**SG** shotgun  
**SS** shotgun shells (4)

through the radioactive pit and hitting the “face” switch on the side of the platform. Before you do any of that, however, you must first kill the four commandos on the platform with you. Oh, and by the way, there are also enemies in each of the four alcoves, so you had better move fast.

Jump off the platform on the north side, grabbing the radiation suit as you land. Proceed to the northwest corner and activate the lift platform as discussed. When you reach the top, kill the three Imps and two Spectres, but don't jump off the ledge you are on just yet. Turn right and activate the switch on the east wall. Then jump off the ledge to the north and grab the berserker pack.

Head up the stairs to the west. Follow the hall and, when it turns to the north, you will run into two commandos and one Imp. After they are dispatched, continue down the hall. When it turns back to the east, there will be three more Imps. Once you are past them, you will enter a room with a T-shaped partition, with the top running east to west and the bottom going north. As soon as you enter the room, there will be an Imp on your right. Kill him and go to the right (south), then immediately left (east). There will be a door halfway down the north wall (on your left). Open it and kill the Imp. Enter the teleporter.

You will emerge in the alcove to the east of the central platform. There will be a Revenant and three Imps (if they are still alive—they often die in the firefight that ensues the first time you cross the central platform). Grab the blue key and head across the walkway, jumping to the center platform. Continue east to the alcove in the east wall and get the rocket launcher. Return to the platform and jump off the northeast side.

Activate the lift in the northeast corner. When you get to the top, there will be two Demons to kill. When they are gone, you find yourself in a large room running west to east with a divider in the middle. Kill the commando on the other side of the divider. Open the blue door in the north wall and flip the switch that is there. This will lower the divider.

There will be two halls running east. Enter the one on the left. You will find a doorway on the left near the end of the hall. Enter it. You fall into a hall with three Imps. Kill them. At the east end of the hall is a door, and at the west end, a raised platform. There is a switch on the south wall. Activating it will open the door on the east end and release a Baron of Hell. Good luck!



## Chapter 6 Intelligence Briefings

When the Baron is dead, flip the switch again and enter the room he came out of in the first place. Inside the room, the door will close behind you and you will find two switches, one each on the north and south walls. Hit the south switch to open the door again, then the north switch to lower the platform on the opposite end of the hall, in rapid succession. Run to the platform before it raises and ride it to the top.

Enter the hall in front of you and get the red key. Follow the hall to the door and open it. You are back in the room with the divider. Go straight to the south wall, then turn east and go down the hall. Just before you turn left, a door at the east end of the south wall will open, releasing three commandos. Kill them and follow the hall to the north. You will see a switch. When you activate it, it will again lower the divider in the previous room. As soon as you hit the switch, you must run back to the other side of the divider before it raises again. This may take some practice, but you are not in any danger while you are trying to get there, so don't get frustrated.

Once you are on the other side of the divider, activate the lift in the southwest corner. When you get to the top, jump off of it and run to the southeast corner of the new location, activating a new lift once you get there. When you ride this one up, there may be a Revenant and three commandos to deal with (again, if they are still alive). Enter the red door in the west wall.

There will be at least two commandos alive in this room, if not more. Go through the exit in the southwest corner of the hall. There will be two commandos in this room as well. Kill them, then activate the switch, and you've got another level under your belt.

### **MISSION 23: BARRELS O' FUN**

You will start on the north end of a long hall facing north. The hall is full of barrels of explosive toxic waste. In the middle of the hall in front of you is a small room, which you cannot get around. Turn to the south, try to pick out the easiest way through the barrels to the south end of the room, and run for it.

Your movement to the south will trigger the room in the north end to open, releasing a Mancubus. He will begin firing at you. The barrels will

## MISSION 23: BARRELS 'O' FUN

### The Bestiary

- AR** Arachnotron  
**AV** Arch-Vile  
**D** Demon  
**FC** Former Human Commando  
**HK** Hell Knight  
**I** Imp  
**M** Mancubus  
**PE** Pain Elemental  
**R** Revenant  
**SM** Spider Mastermind

### Locations

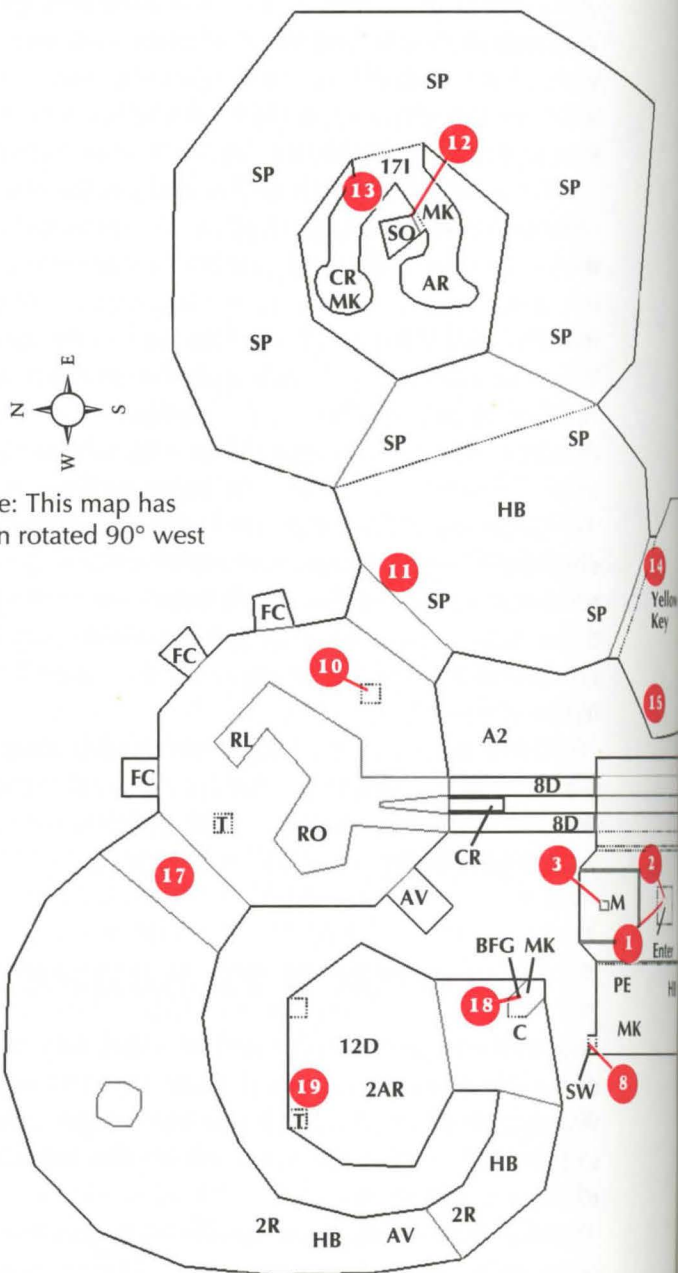
- CM** computer map  
**SW** switch  
**T** transporter

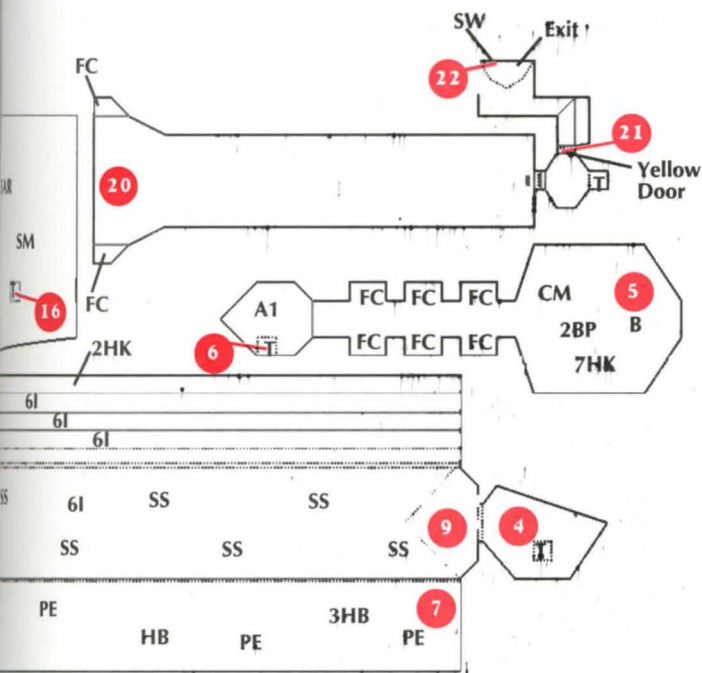
### Special Items

- A1** green armour  
**A2** blue armour  
**B** berserker pack  
**C** energy cell  
**HB** health bonus (vials)  
**MK** medikit  
**SO** soul sphere  
**SP** stimpack

### Weapons & Ammo

- BFG** BFG 9000  
**BP** backpack  
**SW** switch  
**CR** case of rockets  
**RO** rocket  
**RL** rocket launcher  
**SS** shotgun shells (4)





## Waypoints

- 1 Start
- 2 Leaving this area opens (3)
- 3 Room with Mancubus
- 4 Transporter
- 5 Where (4) takes you
- 6 Transporter
- 7 Where (6) takes you
- 8 Switch raises (9)
- 9 Lift platform
- 10 Transporter
- 11 Where (10) takes you
- 12 Secret door, behind it is soul sphere
- 13 Room with tons of rockets, UUURAH!
- 14 Wall that opens when you enter (13)
- 15 Yellow Key
- 16 Transporter
- 17 Where (16) takes you
- 18 BFG 9000
- 19 Transporter
- 20 Where (19) takes you
- 21 Yellow Door
- 22 Exit

block the shots, but they will also set off a chain reaction of explosions heading your way. If you stop to enjoy the cinematic glory of this advancing wall of death, you will be toast. Move it, move it, MOVE IT! Got it Jarhead? Open the door in the south wall and go through it. This will be a small room, empty except for a transporter. Enter the transporter, and you will find yourself in a room full of barrels, facing north.

You will be surrounded by six Hell Knights—not an enviable tactical position, but you don't have a choice, I'm afraid. They are all facing away from you, so you are safe for the moment. To the north you will see a hall running north with barrels lining both sides. Slide to the right of the barrel in front of you, line yourself up with the end of the hall, and run for it. The Hell Knights will now notice you and open fire. Once again the barrels will get hit and set off a chain reaction.

As you move down the hall, you will notice three alcoves on each side with two commandos in each. Ignore them, the exploding barrels will take care of them. At the end of the hall is a small room containing only a transporter. Turn back to the south. You will be able to fire back down the hall, mopping up any of the Hell Knights who may have survived. When they are all dead, go back down the hall and pick up the loot. The hall will have 12 miniguns in it, and the room with the Hell Knights will have a berserker pack, two backpacks, and a computer area map.

Go back to the room at the north end of the hall and enter the transporter. You will exit in another long hall with more barrels in it, though not so many. There will also be six Pain Elementals in the hall. You will be at the south end facing north. Run to the north end, avoiding the Pain Elementals. You will see, in the northwest corner, a switch with a medikit in front of it. Grab the medikit and hit the switch. Your movement toward the switch will trigger the entire east wall to rise. You will be able to see that there is a hallway below the one you are in and another the same height as the one you are in across from you with its west wall open. After flipping the switch, turn right and jump through the opening where the wall was. You will find yourself back in the hall you started in.

Run back to the south end. Here you will find that the door is blocked by a triangular platform that was triggered when you hit the switch. Move up to it and hit **[Spacebar]**. The platform will now lower and you can ride it up. Get off on the left side.

You will see that this hall is laid out like a long set of steps descend-

## Chapter 6 Intelligence Briefings

ing to the east. Head north as fast as you can. There are several Imps, Demons, and two Hell Knights. Blast anything that gets in your way, but keep moving. When you get to the north end, there will be two doorways. Go through the one on the right, and at the end you will see a platform below you in the middle of a lake of toxic waste. Jump to the platform, then quickly drop off the southeast side.

You will land beside a transporter. Get on it. You will now be in a large room with an opening in the northwest corner overlooking the room you just transported out of. Around the walls of the room you will see several stimpacks. You will also see openings in the northeast and southeast corners. Pick up the stimpacks and head through either opening. You will be in a U-shaped hallway that ends at the other opening in the previous wall. In the middle of the hall, in the inside wall, several Imps pour out of an opening. Waste the Imps and enter the opening, where you will find two short corridors leading off from it. At the end of the one on the right are seven cases of rockets, and at the end of the one on the left are six more and a switch. Hit the switch, which will open, revealing a soul sphere. Grab the soul sphere, then go back through the U-shaped hall to the main room.

Here you will see that a section of wall in the southwest corner has opened, releasing five Arachnotrons and a Spider Mastermind. Do not engage them—instead run around them into the room they came out of. Get the yellow key you find here and jump on the transporter.

You will now be in a large room, the east end of which is open and looks out over the area with the pool of toxic waste in it. Move away from the opening. There is an Arch-Vile out there just waiting to do you ugly. You will see this room curves around to the west. Head that way, moving as fast as you can. Two Revenants and an Arch-Vile appear in front of you. Don't stop. You are faster and can outrun them.

Continue around the hall—you will pass two more Revenants—till you see a small raised platform with a cell beside it and a BFG 9000 sitting on it. Move to the platform, activate it, grab the BFG, and turn to your left. You will see a room full of Demons. Give them a quick blast with the BFG and head into the room. The blast will clear out enough of them for you to see the two transporters on the back wall and the two Arachnotrons on the left side of the room.

Charge for the transporter on the left and enter it. You will now find

yourself facing north looking at yet another long hall with barrels in it. Don't stop to think—head for the door in the north end at a dead run. When you entered there was a commando on each side of you who will now be firing at you. They will be the cause of their own demise, as this will set off a chain reaction with the barrels. You will be safely through the door and in a small room. Open the yellow door in the east wall and go through it. Here you will find three barrels along the north wall and another blocking a doorway to the south. Back out of the room and shoot one of the barrels on the north wall. This will cause all four of the barrels to explode, clearing the doorway to the south. Go through it. On the other side you will see another small room with a hole in the floor. Drop through the hole and you have completed another level.

### **MISSION 24: THE CHASM**

You will be in a small room facing north. There is no north wall so you can see that there is a walkway running east to west just outside this room. On the other side of the walkway is a drop-off with a lake of toxic waste at the bottom. In the middle of the lake is a large tower. There is another walkway running from the one outside the room you are in to the tower.

Step out of the room. You will see that the walkway you are on runs east along a wall and disappears around the wall to the east. To the west it continues about 30 feet along the wall, then turns north and runs along another wall, ending at a platform in the northwest corner. In the middle of the west wall is a blue door with a Cacodemon guarding it. Toast him and take the walkway out to the tower.

Where the walkway meets the tower there is a small ledge with a door in the middle of it. Open the door. There will be five Imps on the other side. Kill these guys, using the doorway for cover. Across from the door you will see a wall. Enter the room and turn west. Follow the wall till you come to a short hall running north. Go down this hall. At the end it will turn west, and you will run into an Imp. Kill him and move on. The hall will now turn north again, and you will encounter another Imp. Waste this guy also and get the blue key that is behind him. Exit the tower the way you came in.

## Chapter 6 Intelligence Briefings

Once you are back outside, head for the blue door. When you go through this door you will be on a ledge running north to south. The floor below is covered with toxic waste, and there are a series of partitions coming up from the floor, the tops of which are even with the ledge you are on. You can walk, with difficulty, on the tops of these partitions.

One of the partitions runs up to the ledge you are on. Get your plasma rifle or chaingun ready and walk out on it, heading west, till it intersects with another partition running north to south. Follow this one to the north. It will turn west, then intersect with one running north. Go north, but be ready, a Cacodemon will rise up from the floor behind you. After you kill him, continue north.

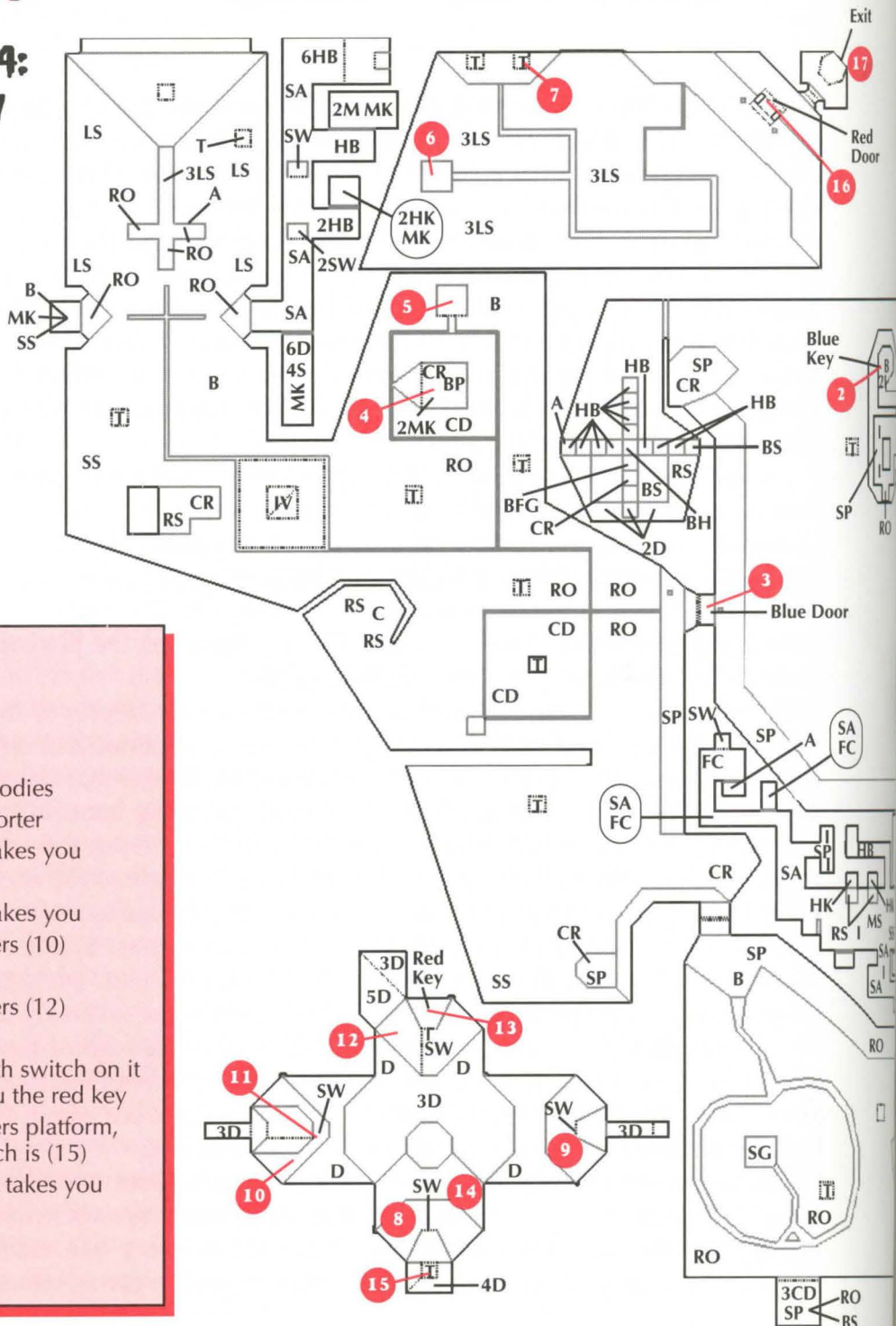
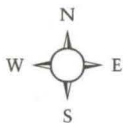
Ahead you can see that the partition you are on connects with others, forming a square around a platform. On the platform are two medikits, a backpack, and a box of rockets. To the north of this platform is another with nothing on it. Work your way around the partitions to the west side of the first platform where it meets one of the partitions. Get on the platform and grab the stuff. This will cause the floor between the platform and the partitions to rise, bringing up a Cacodemon.

After dispatching the Cacodemon, move on to the platform to the north. When you step onto this one you will be transported out and deposited on another platform in a different area. The floor will, like the last, be covered with toxic waste and have partitions rising from it. You will immediately be attacked from all sides by Lost Souls. Once they are dead, you will notice a platform in the northeast corner with a red door on it. There is also a platform on the north wall with two transporters on it. Walk along the top of the partitions to the transporters. Scattered around them you will find two medikits, two rockets, a clip, and four shotgun shells. Grab this stuff and enter the silver transporter on the right.

The first thing you will see are six Demons charging toward you. Mow these guys down, then take a look around. You will be in the south arm of an X-shaped room facing north. In each of the arms is a switch on a platform. The only switch you can reach is in the east arm.

Move out into the center of the room. This will cause two more Demons to attack you, one from the east and one from the west. Make fast work of them and move to the switch in the east arm of the room. Flipping the switch causes the platform in the west arm to lower, releas-

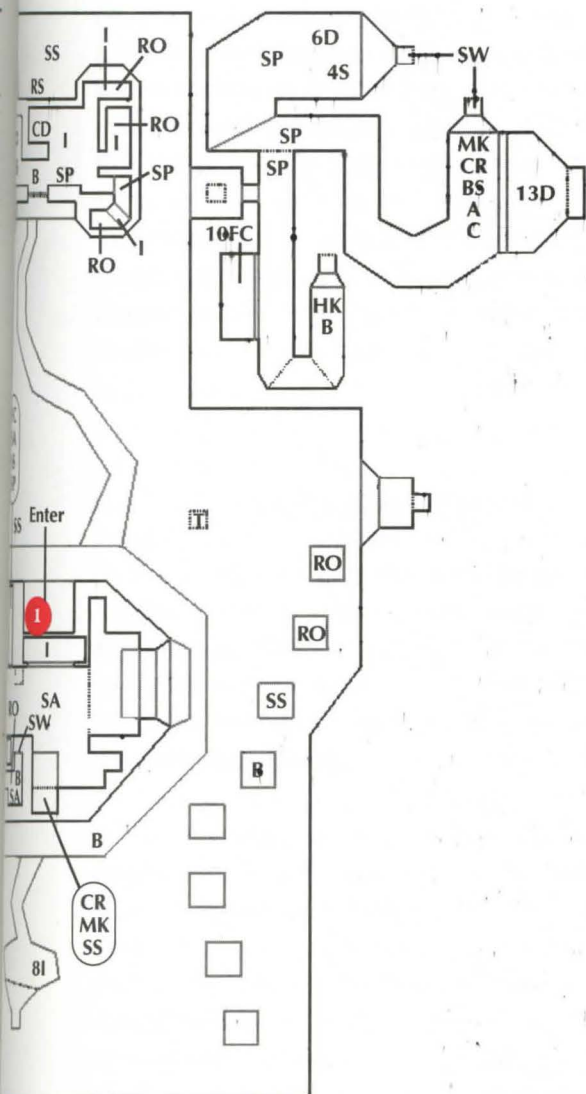
# MISSION 24: THE CHASM



## Waypoints

- 1 Start
- 2 Blue key
- 3 Blue door
- 4 Cache of goodies
- 5 Secret teleporter
- 6 Where (5) takes you
- 7 Transporter
- 8 Where (7) takes you
- 9 Switch lowers (10)
- 10 Platform
- 11 Switch lowers (12)
- 12 Platform
- 13 Platform with switch on it that gets you the red key
- 14 Switch lowers platform, behind which is (15)
- 15 Transporter, takes you back to (7)
- 16 Red door
- 17 Exit





### The Bestiary

- BH** Baron of Hell
- CD** Cacodemon
- D** Demon
- FC** Former Human Commando
- I** Imp
- HK** Hell Knight
- LS** Lost Soul
- M** Mancubus
- S** Spectre

### Locations

- SW** switch
- T** transporter

### Special Items

- B** berserker pack
- C** energy cell
- HB** health bonus (vials)
- IV** invulnerability sphere
- MK** medikit
- MS** megasphere
- RS** radiation suit
- SA** spiritual armour
- SP** stimpack

### Weapons & Ammo

- A** box of ammo
- BFG** BFG 9000
- BP** backpack
- BS** box of shells
- CR** case of rockets
- RO** rocket
- SG** shotgun
- SS** shotgun shells (4)

ing three Demons. By the time you have killed them the platform will have risen, so hit the switch again, run over to the lowered platform, and ride it up. Hit the switch at the top. This will cause the platform in the north arm to lower, releasing 12 more Demons. Once again, by the time you have turned these guys to fodder, the platform will have risen, so do the switch thing again.

Run over to the platform and ride it up. Hit the switch at the top of this platform, and the section the switch is in will lower, revealing the red key. Go back to the south arm of the room and hit the switch there. As soon as you do, start backing up. The switch will lower the platform, releasing four more Demons and revealing a transporter. Blast the Demons and hop on the transporter.

You will be back on the transporter that took you to the last room. Follow the tops of the partitions to the door in the northeast corner and open it. Go through the door on the other side, and you will see a small room with an Exit door in it. Go through the Exit door into another small room and drop through the hole in the floor.

## **MISSION 25: BLOODFALLS**

You start in a large room with a stream of blood running from the north to the south. In the center of this, running off to the east, is another stream of blood. Both of these streams run into openings in the walls. Make no mistake, this is evil blood and will do damage to you if you stand in it or walk through it. Unfortunately, it will not be possible for you to completely avoid it on this level, so when you have to move through it, do so quickly.

In front of you is the super shotgun. Pick it up and quickly cross the stream in front of you. Follow beside the stream running east till you are about six feet from the wall. Step into the stream and run toward the east wall. When you go through the opening you will fall down a bloodfall and land in front of a transporter in a hall through which another stream of blood flows. There will be two Sergeants in front of you and a bloodfall in the middle of the wall to the right. Kill the Sergeants and charge through the bloodfall with your gun blazing. On the other side will be a

## Chapter 6 Intelligence Briefings

hall with some Former Humans, Sergeants, and stimpacks in it. Blast the bad guys, but watch out for the barrels in the middle of the hallway.

Continue to the end of the hall, where you will find green body armor and another stimpack. Go back to the beginning of the hall, step back into the stream, and head east.

At the end of the hall is a doorway and dry land. Through the doorway you can see a Revenant on a tower in the middle of a room. Around the tower are four Sergeants. At the top of the walls in this room is a walkway with a barred wall along the inside. Patrolling around this walkway are several Sergeants, commandos, and Imps. From the doorway, kill the Revenant and the Sergeants around the tower. Then head through the room to the east wall and hit `[Spacebar]` when you are in the center of it. This section of wall will lower, allowing you to cross it and enter a tunnel on the other side or ride it up to the walkway. Enter the tunnel and follow it as it curves to the north, picking up the cells you will find along the way.

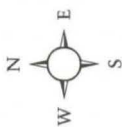
You come to a large chamber where you will encounter a Hell Knight with several Sergeants and a commando around him. Wipe them all out and go through the opening on the north side of the chamber. Here you will encounter three more Sergeants. There will be corridors to the left and right. Take the corridor to the left. At the end another Sergeant is standing beside a transporter. Kill him and get on the transporter.

You will now find yourself at the south end of a very short hall facing north. In front of you, at the end of the hall, you can see two Lost Souls facing away from you. In front of the Lost Souls is a stream of blood flowing from west to east through the opening in the northeast corner of the hall. Kill the Lost Souls, grab the blue key that is in front of them, and jump through the opening.

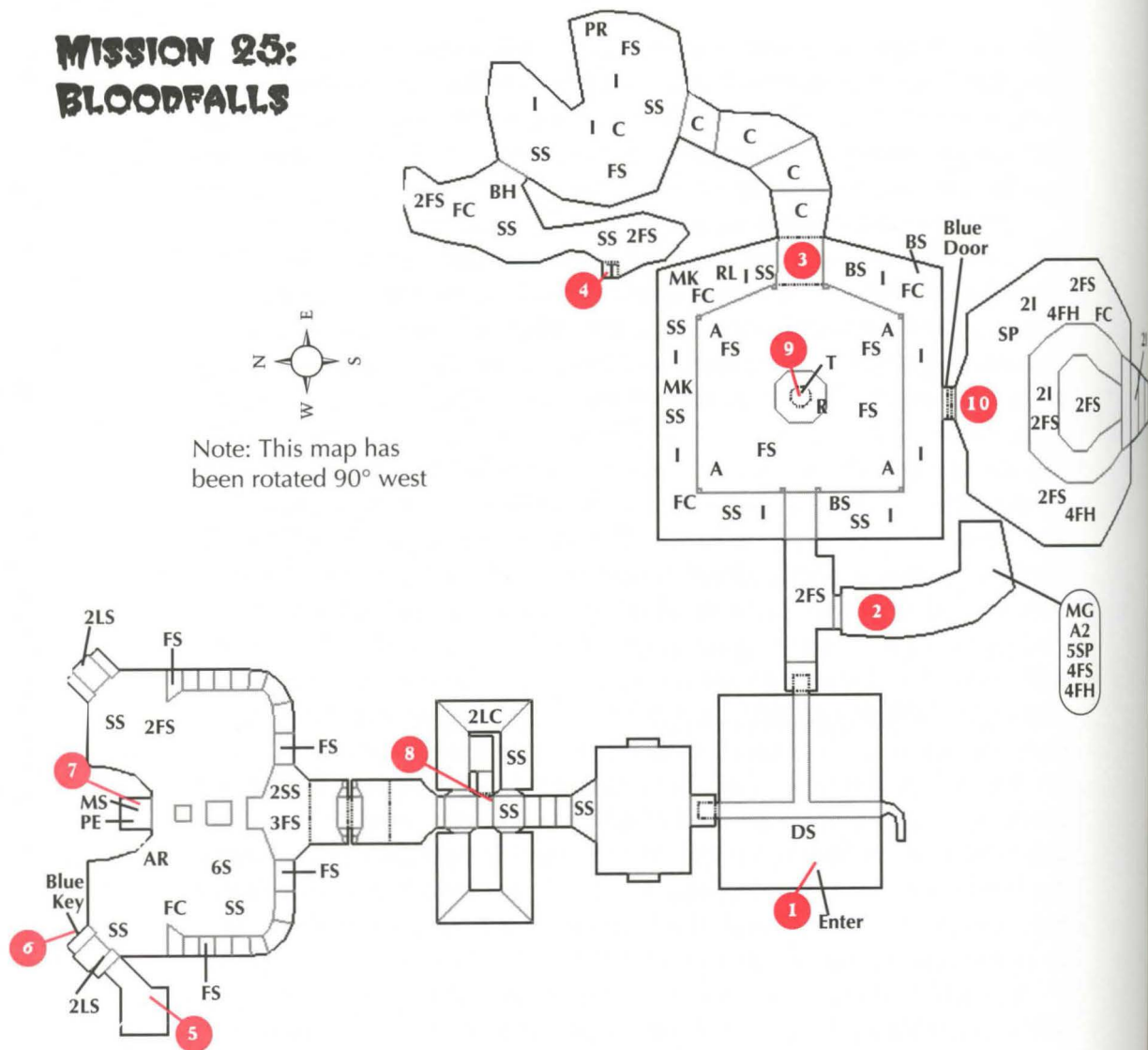
You will be in the north end of a large room with stairways going up to the south along the east and west walls. The floor is a lake of blood, and there are Spectres running around in it. Head for the stairs along the west wall and go up them, killing the Sergeants who will be in your way. You will hear an Arachnotron moving around on the floor, so get to the top of the steps ASAP.

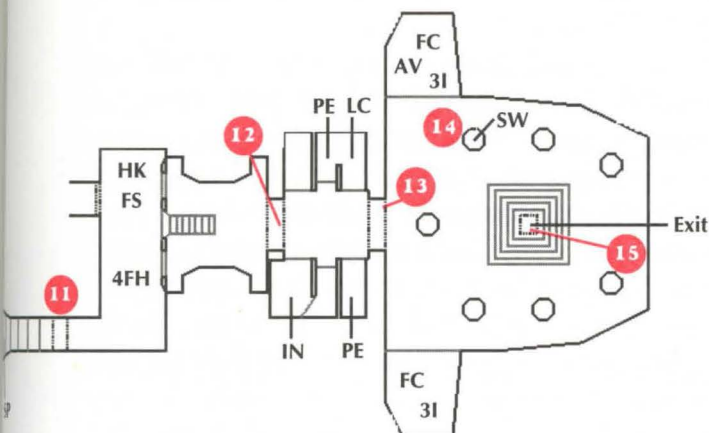
At the top of the stairs is a door and in front of it, running to the north, is a series of towers. Run across these and jump into an alcove in the north wall. Grab the megasphere in the alcove, jump down from the

## MISSION 25: BLOODFALLS



Note: This map has been rotated 90° west





### The Bestiary

- AR** Arachnotron  
**AV** Arch-Vile  
**BH** Baron of Hell  
**FH** Former Human  
**FC** Former Human Commando  
**FS** Former Human Sergeant  
**I** Imp  
**HK** Hell Knight  
**LS** Lost Soul  
**PE** Pain Elemental  
**R** Revenant

### Locations

- SW** switch  
**T** transporter

### Special Items

- A1** green armour

- A2** blue armour  
**C** energy cell  
**IN** invisibility sphere  
**LC** large energy cell  
**MK** medikit  
**MS** megasphere  
**SP** stimpack

### Weapons & Ammo

- A** box of ammo  
**BP** backpack  
**BS** box of shells  
**DS** combat shotgun (super shotgun)  
**MG** machine gun (chain gun)  
**RO** rocket  
**PR** plasma rifle  
**RL** rocket launcher  
**SS** shotgun shells (4)

### Waypoints

- 1 Start, with super shotgun in front of you
- 2 Secret passage behind "bloodfall"
- 3 Lift platform
- 4 Transporter
- 5 Where (4) takes you
- 6 Blue key
- 7 Megasphere
- 8 Secret door
- 9 Transporter, takes you back to (1)
- 10 Blue door
- 11 Lift platform
- 12 Lift platform
- 13 Lift platform
- 14 Switch activates stairs around (15)
- 15 Exit

alcove to the east, and head up the east stairs, blasting anything that gets in your way. Go through the door, and you will be in a stairway going down to the south.

On both sides of the stairs are two windows. Face the wall between the windows in the east wall and hit **[Spacebar]**. A secret door opens. Go through it, and you will come to the U-shaped room the windows are in. In the bottom of the U are two large cells. Get them and exit the room.

Continue down the stairs till you come to a small room with a floor covered in blood. Across from you, in front of a bloodfall, is a transporter. Run over and jump on it. You will be back where you first started. Retrace your path to the room with the walkway around the top. Watch your back—there are still bad guys on the walkway. Go to the east wall and activate the platform again. This time, instead of crossing to the tunnel, ride it up and get off on the walkway. Run around it and kill everything that is still alive. Once the monsters are dead, start picking up all the stuff laying around. There will be medikits, ammo, shotgun shells, a rocket launcher, plus all the stuff the bad guys had.

Go to the south wall and open the blue door. Inside will be several Imps, Sergeants, and Former Humans. Use the doorway for cover and kill everything inside. Enter the room and go to the south end. Here you will find a set of stairs going down. At the bottom is a platform, on top of which are a few Sergeants and a Hell Knight. Wipe out everything on the platform and go down the stairs. Hit **[Spacebar]**, and the platform will lower, and you can ride it to the top.

At the top there is a set of stairs running down to the south into a small room with a lift in the south wall. Step on the lift, and you will be lowered into another small room with a cage in each corner. There are two short halls, one on the west side between the two cages on that side and another on the east side between the other two cages. In each of these halls is a Pain Elemental. Kill both of them and get the goodies out of the cages. The one in the southeast corner has two large cells in it, and the one in the northwest corner has an invisibility sphere in it.

There is a lift on the south wall of this room also. Get on it, and it will lift you up to a room in the middle of which is a square room with no doors. Around the center room are seven pillars. In the north end of both the east and west walls are rooms, each with a handful of Imps and two

## Chapter 6 Intelligence Briefings

commandos. The room on the east wall also contains an Arch-Vile. Run into the main room on the west side and circle around the center room till you are close to the opening in the east wall. Watch your back—the bad guys are after you. By this opening is a pillar with a switch on the west side. Hit the switch and start firing into the opening in the west wall while you are backing toward the room in the center. The switch will cause the walls of the center room to lower, revealing stairs on each side that lead up to what looks like a transporter. Head up the stairs, and at the top the level is over.

### MISSION 26: THE ABANDONED MINES

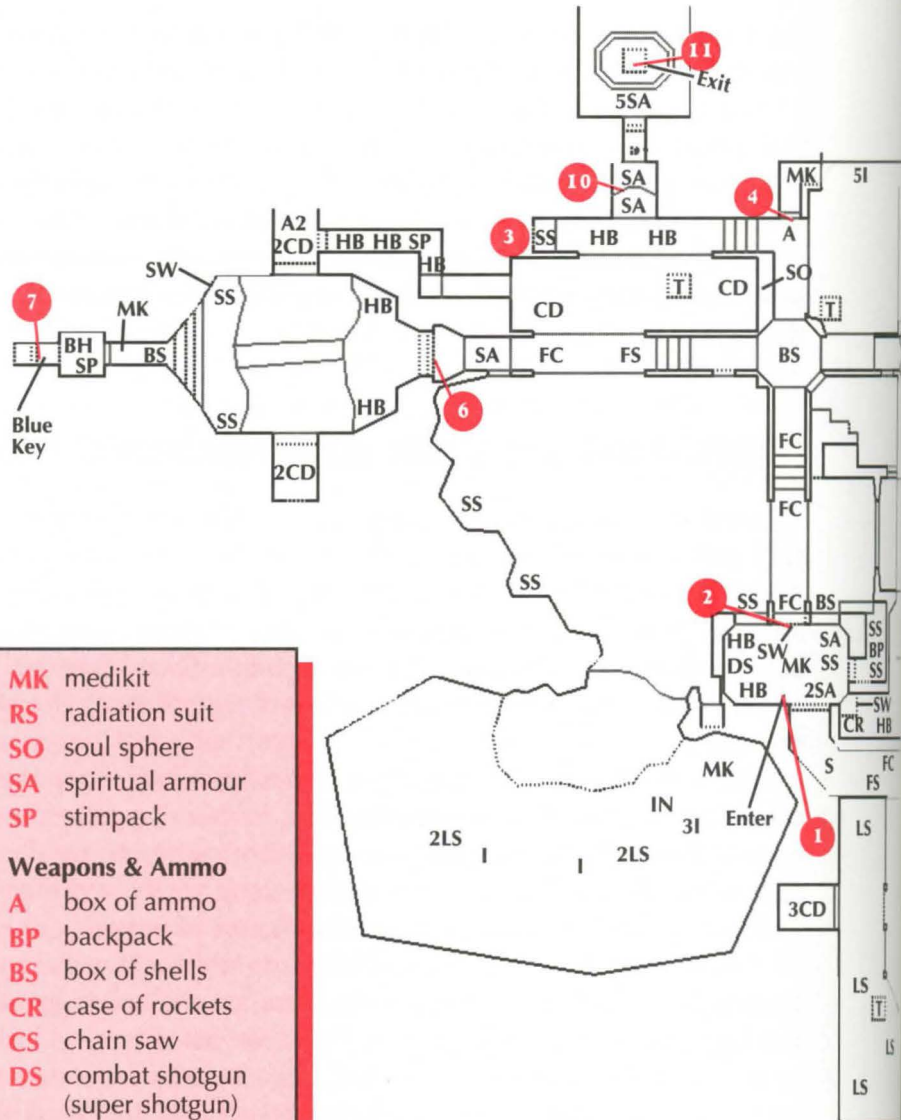
You will be in a small room facing north. In front of you is a switch. On each side of the switch are barred windows. Scattered around you on the floor you will find, three spirit armors, two medikits, three health bonuses, four shotgun rounds, and a super shotgun. Grab the stuff and activate the switch. The floor will lower one story, and there will be a hall in front of you with two commandos in it. Kill them and follow the hall to the north.

All of the halls in this level have barred openings along the walls, so watch out for snipers. You will come to a set of stairs going down, with a commando at the bottom. Kill him and continue north past an intersection, where you will pick up a box of shotgun shells, and then on to the end of this hall, where you will find three cases of ammo.

There will be a set of stairs going up to the east with two Cacodemons at the top. Dispatch the Cacodemons and trigger the switch behind them. In the north wall you will see an alcove with the yellow door in it. Remember this for later. Go back down the stairs, and at the bottom you will see that the switch opened a secret door leading north.

Go through into a small hall that turns east. At the turn you can see into a room with a walkway running from the end of the hall you are in along the north wall, then along the east wall. Below, the floor is covered with toxic waste. Along the walkway are several Imps. Blast these guys and move down the walkway. At the corner of the north and east walls you will find the red key. Along the east wall you will find four medikits

## MISSION 26: THE ABANDONED MINES

**The Bestiary**

- BH** Baron of Hell  
**CD** Cacodemon  
**FC** Former Human Commando  
**FS** Former Human Sergeant  
**I** Imp  
**LS** Lost Soul  
**M** Mancubus

**Locations**

- SW** switch  
**T** transporter

**Special Items**

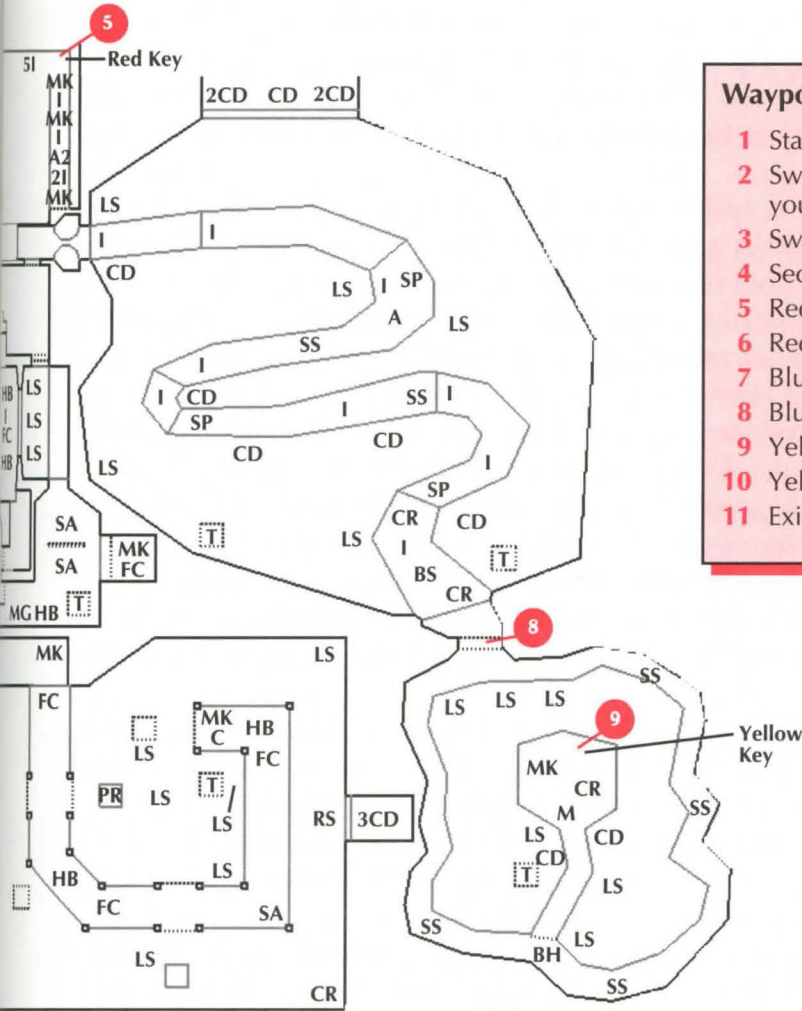
- A2** blue armour  
**C** energy cell  
**HB** health bonus (vials)  
**IN** invisibility sphere

- MK** medikit  
**RS** radiation suit  
**SO** soul sphere  
**SA** spiritual armour  
**SP** stimpack

**Weapons & Ammo**

- A** box of ammo  
**BP** backpack  
**BS** box of shells  
**CR** case of rockets  
**CS** chain saw  
**DS** combat shotgun (super shotgun)  
**MG** machine gun (chain gun)  
**RO** rocket  
**PR** plasma rifle  
**SS** shotgun shells (4)





### Waypoints

- 1 Start
- 2 Switch lowers floor of the room you are in
- 3 Switch opens (4)
- 4 Secret door
- 5 Red key and goodies
- 6 Red door
- 7 Blue key
- 8 Blue door
- 9 Yellow key and goodies
- 10 Yellow door
- 11 Exit

and green body armor. Exit this room and go back through the secret door.

Follow the hall to the south till you reach the intersection, then turn west. You will come to a stairway going down to the west with two commandos, a Sergeant, and a helmet at the bottom. At the end of this hall is a red door. Open the door, and you will be looking at a lake of toxic waste. On the west end of the room is a set of stairs going up. Run across to the stairs and go to the top. Here you will find two medikits and a box of shells.

To the west you will see an alcove with the blue key in it. Between you and the alcove is a pit in the floor. When you moved up the stairs you triggered the floor of the pit to rise, bringing a Baron of Hell up with it. Banish him back to the Abyss, then cross to the alcove and get the blue key. Turn around and go back to the top of the stairs.

Coming out of openings at the top of the north and south walls you will see four Cacodemons. Waste these guys, using the stairs for cover, then run back to the door you came in. Go to the east end of this hall, and you will be looking into a large cavern. There is a raised walkway winding toward the southeast corner, where you will see the blue door. Along the walkway will be several Imps, and rising from the floor will be Lost Souls and five Cacodemons. Kill them all from the doorway, then follow the walkway—picking up the loot you will find on the way—to the blue door.

Open the door, and you will see a cavern with a walkway all the way around it and the floor several feet below. In the middle of the cavern is a raised platform with a Mancubus on top of it. There will also be a Baron of Hell on the walkway by the south wall. Five Lost Souls and two Cacodemons will rise from the floor. Use the doorway for cover and hammer these guys.

Follow the walkway around to the south side, take the walkway to the center platforms, and grab the stuff you find here. There will be the blue key, two cases of rockets, and two medikits. Go back to the blue door. Looking back into the room with the winding walkway, you will be able to see that five Cacodemons have entered this chamber. Kill them from the doorway and go back across the walkway and back into the hall.

Head west down this hall to the intersection and turn north. Follow this to the end, go up the stairs on your left, and enter the blue door in the

## Chapter 6 Intelligence Briefings

alcove on your right. You will be in a small room with a hole in the floor. Around the hole are five helmets. Pick these up and jump in the hole.

### MISSION 27: MONSTER CONDO

You will be facing north into an L-shaped room running north and east. In the west end of the north wall is a pool of toxic waste. The majority of the pool is in this room, but it extends north into the corridor on the north side of the north wall. There is a stairway running up from the southeast corner of the pool to the center.

Go up the stairs. As you climb the stairs you will find eight shotgun shells, a stimpack, a clip, and a rocket launcher at the top. As you reach the top you will notice that a section of wall in the northeast corner is opening, and seven Spectres are coming into the room. Stay on top of the stairs and kill them. You will see a chaingun by the east wall. Go back down the stairs and through the opening the Spectres came out of. Here you will find eight health vials, a stimpack, a backpack, an invulnerability sphere, light amplification goggles, two cases of ammo, and a case of rockets. Grab all this and exit this room.

Follow the edge of the pool to the east, avoiding the chaingun by the east wall. At the east end of the hall you will see a door in the east wall. Go through the wall, and you will be in a small library with a rocket in the southeast corner. When you get the rocket, the south and east walls will lower, revealing an even bigger library with a few Sergeants, an Imp, and a Commando inside. Kill these guys without leaving the section of floor you are on.

To the south you will see a bookshelf about 10 feet long, running east to west in the middle of the room. To the east of this you will see a second 10-foot bookshelf with a switch on it running from the south wall north into the room. To the east of this another bookshelf with a switch at the end is coming off the south wall, and it is joined by yet another bookshelf coming off the east wall and blocking off the corner of the room.

Move east into the room. You will be attacked by Spectres from behind the bookshelf running east to west and Demons from behind the bookshelf coming off the north wall. This bookshelf will lower and on

## MISSION 27: MONSTER CONDO

### The Bestiary

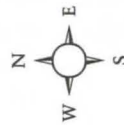
- AR** Arachnotron
- AV** Arch-Vile
- BH** Baron of Hell
- D** Demon
- FB** Final Boss
- FH** Former Human
- FC** Former Human Commando
- FS** Former Human Sergeant
- I** Imp
- HK** Hell Knight
- LS** Lost Soul
- M** Mancubus
- R** Revenant
- S** Spectre
- SM** Spider Mastermind

### Special Items

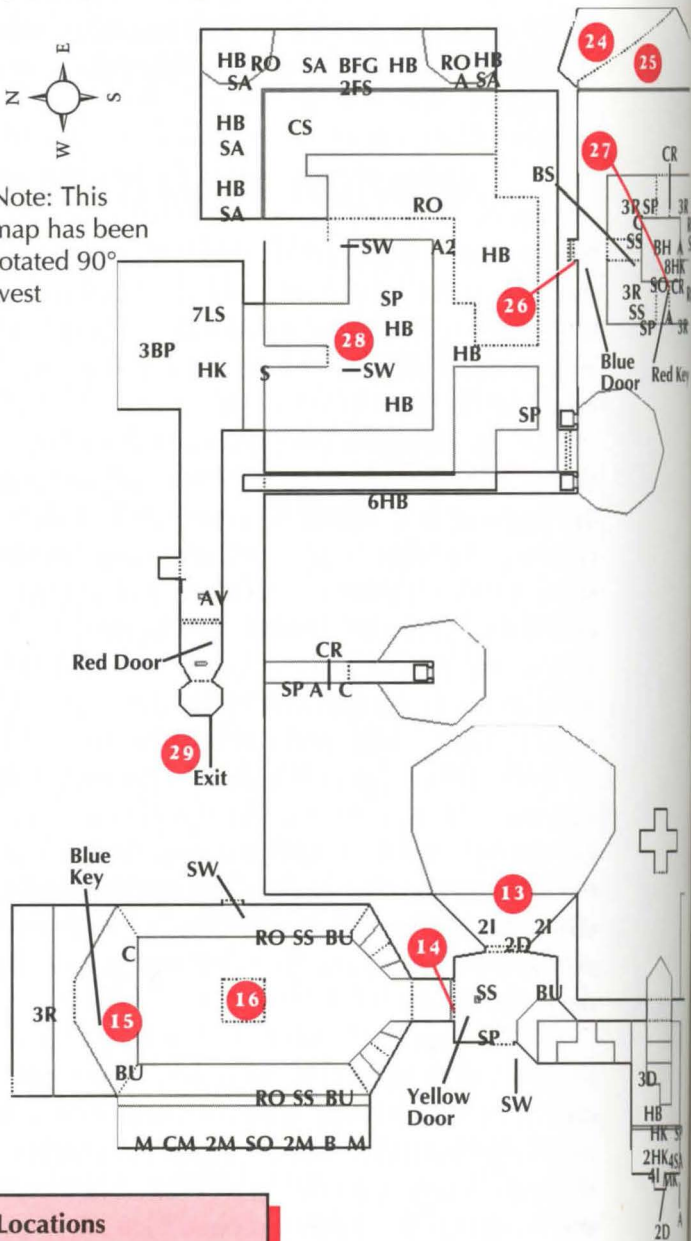
- A1** green armour
- B** berserker pack
- C** energy cell
- HB** health bonus (vials)
- IN** invisibility sphere
- IV** invulnerability sphere
- LC** large energy cell
- LG** light goggles
- MK** medikit
- SO** soul sphere
- SA** spiritual armour
- SP** stimpack

### Weapons & Ammo

- A** box of ammo
- BFG** BFG 9000
- BP** backpack
- BS** box of shells
- BU** bullets (10)
- CR** case of rockets
- CS** chain saw
- DS** combat shotgun  
(super shotgun)
- MG** machine gun (chain gun)
- RO** rocket
- RL** rocket launcher
- SS** shotgun shells (4)

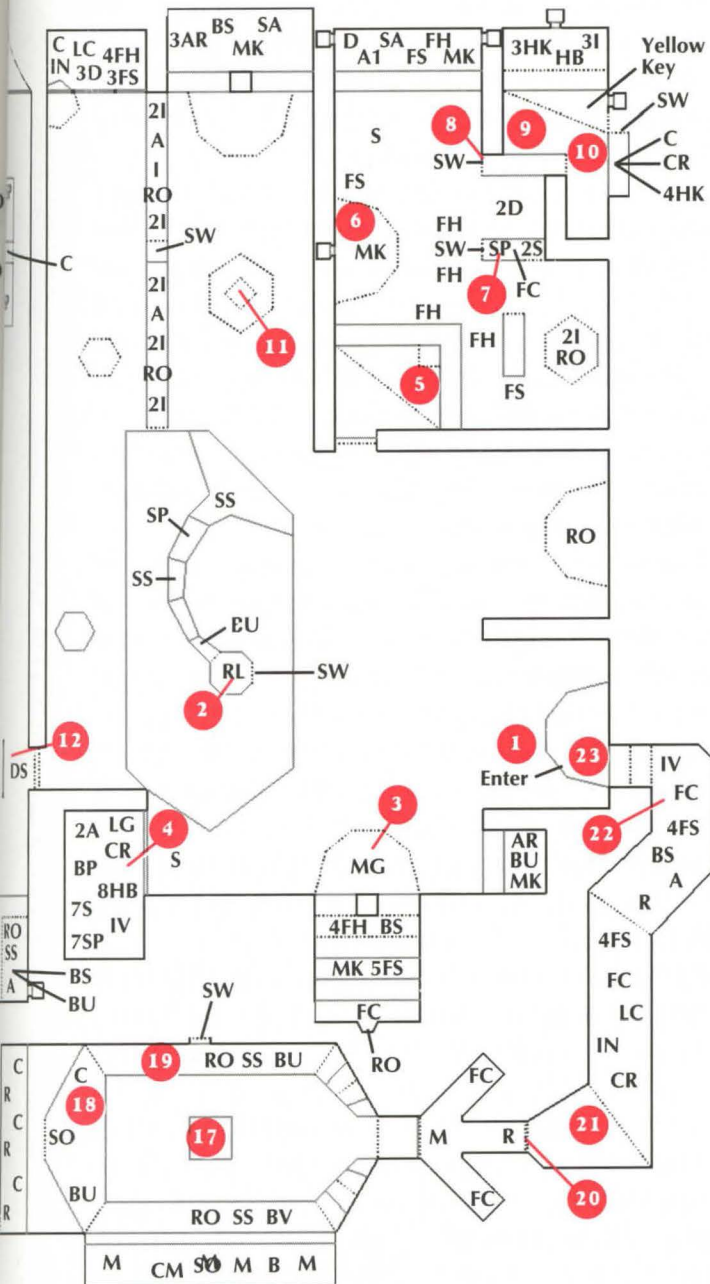


Note: This map has been rotated 90° west



### Locations

- CM** computer map
- SW** switch
- T** transporter



## Waypoints

- 1 Start
- 2 Rocket launcher
- 3 Chaingun
- 4 Invulnerability & lots of other goodies
- 5 Picking up rocket lowers south and east walls
- 6 Moving through this area lowers bookcase
- 7 Switch lowers bookcase it is on
- 8 Switch lowers bookcase behind it
- 9 Room contains Yellow Key and other goodies
- 10 Switches in north and south walls
- 11 Moving close to skulls lowers north wall
- 12 Super shotgun
- 13 Switch lowers section of floor
- 14 Yellow Door
- 15 Blue Key
- 16 Secret teleporter
- 17 Where (16) takes you
- 18 Soul sphere
- 19 Switch opens west wall
- 20 Secret door
- 21 Wall lowers to reveal hallway
- 22 Box of ammo and invulnerability sphere
- 23 Secret teleporter
- 24 Where (23) takes you
- 25 Wall opens when you hit spacebar
- 26 Blue Door, behind which is a switch
- 27 Red Key
- 28 Switch lowers section of floor
- 29 Exit

top, you will see a commando and an Imp. After you kill all these monsters the bookshelf will have gone back up. Hit the switch on it, and the bookcase that runs east to west will drop, releasing a Hell Knight and Revenant that are on top of it. Blast these guys and grab the invisibility sphere and stimpack that are also on top of the bookshelf.

Move to the east end of the room and hit the switch in the south wall. The section of wall behind the switch will open, releasing an Arch-Vile and four Hell Knights. Blast these puppies and enter the room they came out of. You will be in a small room. In here you will find a plasma rifle, a case of rockets, an invulnerability sphere, and the yellow key. Grab the key last. When you do, the east wall will rise, releasing three Hell Knights. Kill these guys while you are still invulnerable and grab the three health vials and two cells from the alcove the Hell Knights came out of.

On the south wall of this room is a switch—activate it and turn around. In front of you will be another switch—activate this one also. A section of the south wall will lower behind you, releasing another Hell Knight. Quickly, while you are still invulnerable, get the case of rockets and the cell on top of the lowered section of wall. This will also have revealed a switch which, when activated, will raise the section of wall you entered and allow you back into the rest of the library.

Exit the library, turn north, and go around the corner to the east. In the middle of this part of the room will be what looks like a reddish-yellow floating table with two skulls on it. Brush against this, and the north wall will lower in two sections with Imps on top of each. Blow a hole through the Imps and cross the wall. The wall will rise back up, trapping the Imps on the other side.

You will be in a long hallway running west. It will be very dark except for rays of light coming in from the roof. Follow the north wall west to the end, where you will find a door leading north. Open this door and go through.

This is another large room running to the north and east. In front of the door is a super shotgun. On the other side of the shotgun is a partition with an arrow cut out of it pointing west. In the east end of the room you will see a large square room. From the middle of the north wall running south is a bookshelf. There is an X-shaped bookshelf behind the arrow and to the west.

## Chapter 6 Intelligence Briefings

In the north wall of the east end of the room are two doors. One is a blue door and one is a normal door. In the east wall you will see a switch. Go activate it. This will cause a large section of floor around where you are standing to lower. Stay facing west and back up. When the floor gets to the bottom you will see a door in front of which are four Imps and two Demons. Waste these guys and go through the door.

On the other side of the door is a small room with a yellow door in the north wall, a switch in the west wall, and a hall going to the south. Go through the yellow door, and you will be in a large room with a stairway on each side of the doorway leading up to a walkway that goes around the whole room. In the middle of the east wall you will see a switch that you can reach from the walkway. You will also see the blue key on the walkway in the north end of the room. Go up either set of stairs and around the walkway collecting the goodies—rockets, shells, cells, and clips. In the middle of the room is a platform.

Walk across the platform, and you will be transported to another room exactly like the one you were just in, except instead of a blue key in the north end there is a soul sphere. Collect the stuff off the walkway in this room, then go to the switch in the east wall. When you trigger this the east wall will open, revealing six Mancubuses. Turn and shoot the north wall, which will cause it to rise, releasing three Revenants. Run past them into the room they were hiding in and hit the switch in the north-west corner. The Revenants and Mancubuses should be hammering at each other. Jump off the walkway onto the floor and head for the door in the south wall. There will be another Mancubus and two commandos in your way. Blast them and move through the door. In front of the door are three hallways whose floors are covered with toxic waste. Head down the middle hall and at the end hit **Spacebar**, and the wall will rise.

You will be in a triangular room with a gray wall to your left. Hit **Spacebar** again and the wall will lower, revealing a section of hall going east with five Sergeants and a commando in it. At the end of this hall is a raised section of the hall continuing east, with three commandos, two Sergeants, and a Revenant. Kill everything on the lower level and grab the case of rockets, the large cell, and the invisibility sphere.

The section of hall you are in will lift you up till you are level with the other section of hall. Wipe out all the bad guys on the upper level

and pick up the box of ammo and the invulnerability sphere. Go to the panel in the northeast corner and activate it. The panel will lower, leading through the north wall to the exact place you started this level.

When you move through the opening you will be transported to a small empty room. Activate the east wall and it will open. You will be in the east end of the room in which you saw the arrow cut out of the partition. The walls of the room you saw here earlier will have lowered, leaving only a large pillar from floor to ceiling surrounded by 12 Revenants. Move down the north wall, open the blue door, and activate the switch behind it. This will cause the pillar to lower, releasing the seven Hell Knights and a Baron of Hell that are on top. Back away to the east and let these guys mix it up a bit.

Run back to where the pillar lowered and get the red key. Head west again and enter the regular door in the north wall. You will be in a room with many of your former comrades-in-arms hanging from the ceiling. Running south from the north wall are two partitions about eight feet long, with a switch at the end of each. Go to the one on the left and hit the switch. A large section of floor around you will start to lower. When you get to the bottom you will be able to see a small room on the north with five Lost Souls, a Hell Knight, and a soul sphere inside. Run in, grab the soul sphere, and run into the hall in the west wall. There will be an Arch-Vile here. Pass him and go through the red door in the north wall at the end of the hall. On the other side is a small room with a hole in the floor across from the door. Jump in.

## **MISSION 28: THE SPIRIT WORLD**

You will start in an oval room facing north with a chainsaw on the floor in front of you. Man, I love it when when that happens. There will be a red door in the east wall. You will see openings in the northeast and northwest. Grab the chainsaw and exit through the northwest opening.

You will find yourself in a corridor that widens as it curves to the south. Run through this, staying against the right side wall. You will pass three Imps, two Demons, and three Pain Elementals. The corridor ends with a wide opening overlooking the floor a few feet below. Through the



## Chapter 6 Intelligence Briefings

floor will be streams of what look like lava. Jump to the floor and head southeast.

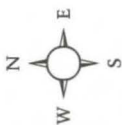
Ahead of you is a column with openings on each side. Head for the opening on the left. There will be one place where the opening is higher. Jump through this. You will land in a hall that has lava covering the floor. The hall runs south, then west. Follow it to the end. Here you will be on a raised platform running out into a lake of lava. To the southeast you will see a pillar in front of a narrow section of wall at the end of the platform. Run to the pillar and get the invulnerability sphere on the southeast side. In the lake to the northeast you will see many Arachnotrons. Jump off the east side of the platform into the lake and head northeast. Work your way around the Arachnotrons and help yourself to the seven large cells you will find against the northeast wall. Turn back to the southeast again, working past the Arachnotrons. Here you will find a Spider Mastermind and two more invulnerability spheres. Grab another sphere and follow the lake around till you see a set of stairs on the left side.

Run up the stairs. At the end you will enter the northeast corner of a room. In the middle of the room is a platform that is raised to the ceiling. There will also be four columns around the platform. The west end of the room is slightly raised, and on it will be what looks like a large red chair surrounded by four rockets. Run up into the chair. This will cause the platform in the middle of the room to lower. Run over, get on the platform, and ride it up. At the top you will see two switches, one to the north and one to the south. Activate the switch to the north and jump off the platform. You will see that a doorway has opened in the northwest corner. In the middle of this doorway is the red key. Grab the key, then exit this room the way you came in.

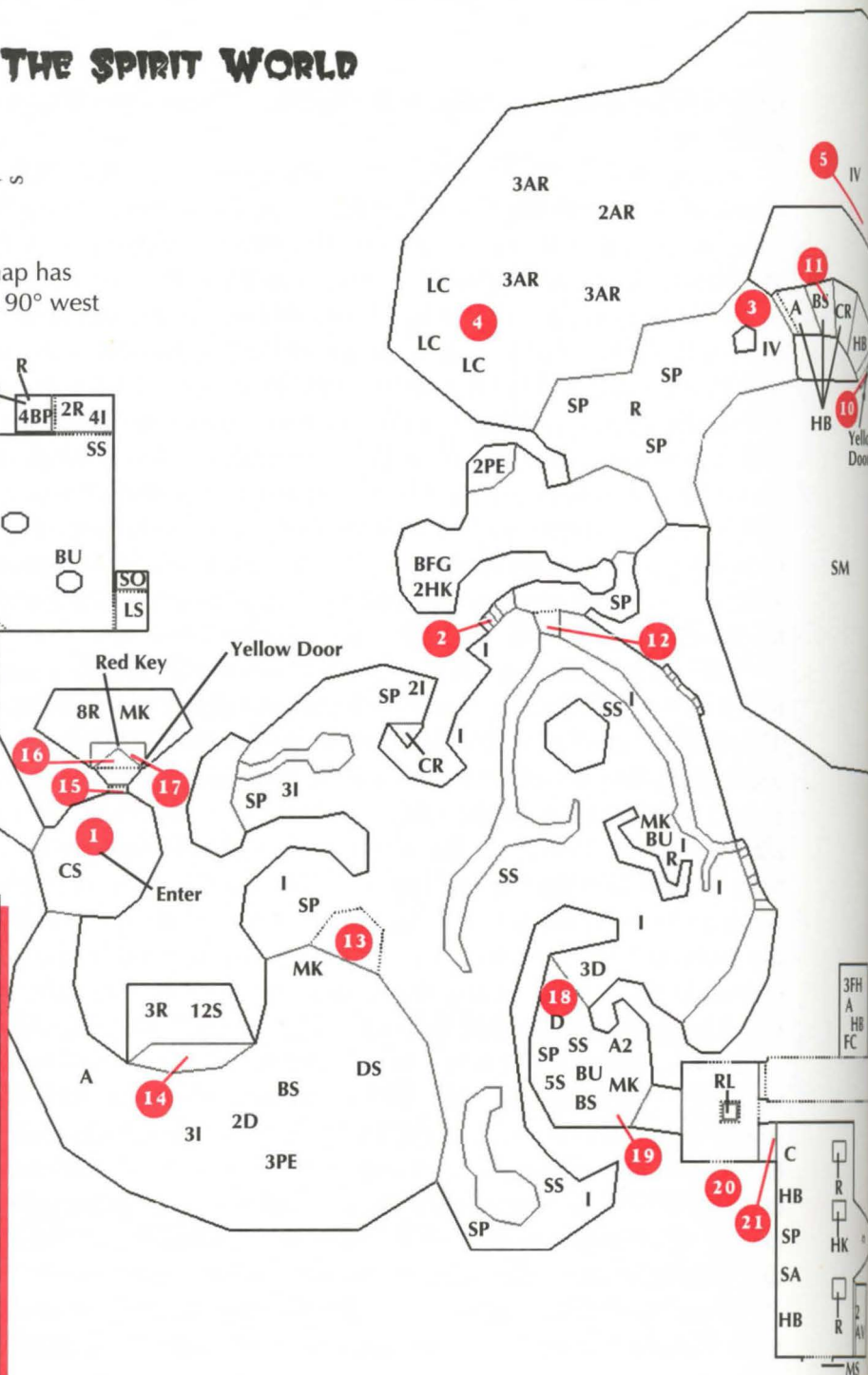
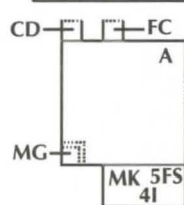
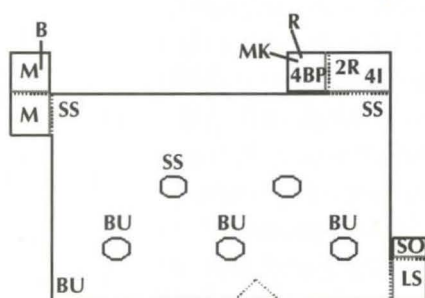
Run back down the stairs. In the lake ahead of you will be an invulnerability sphere to the right and a yellow door to the left. Avoid the Arachnotrons that are still running around, grab the sphere, and head for the yellow door. Open the door and go through. On the other side is a set of stairs going up. Follow them to the top, picking up the goodies you find lying on them. At the top is a wall. Hit `[Spacebar]` and it will lift. You will now be back on the platform that runs out into the lake.

Head northwest, back to the hallway you used to get here the first time. Follow the hall till you come to a lavafall on the left. Face the

## MISSION 25: THE SPIRIT WORLD



Note: This map has been rotated 90° west



## Special Items

- A2** blue armour
- B** berserker pack
- C** energy cell
- HB** health bonus (vials)
- IV** invulnerability sphere
- LC** large energy cell
- MK** medikit
- MS** megasphere
- SO** soul sphere
- SA** spiritual armour
- SP** stimpack

**The Bestiary**

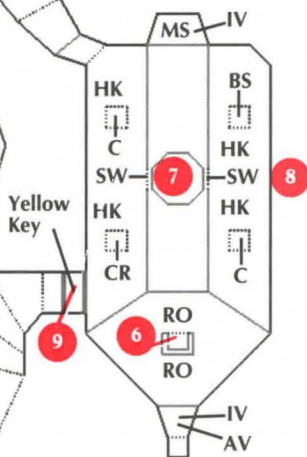
**AR** Arachnotron  
**AV** Arch-Vile  
**CD** Cacodemon  
**CY** Cyberdemon  
**D** Demon  
**FH** Former Human

**FC** Former Human  
 Commando  
**FS** Former Human  
 Sergeant  
**I** Imp  
**HK** Hell Knight  
**LS** Lost Soul  
**M** Mancubus

**PE** Pain Elemental  
**R** Revenant  
**S** Spectre  
**SM** Spider  
 Mastermind

**Locations**

**SW** switch

**Waypoints**

- 1 Start, with chainsaw in front of you
- 2 Opening in wall
- 3 Invulnerability
- 4 7 Large energy cells
- 5 2 Invulnerability spheres
- 6 Large chair activates (7)
- 7 Lift platform
- 8 Switch opens (9)
- 9 Secret door, Yellow Key
- 10 Yellow Door
- 11 Cache of goodies
- 12 Lift platform (looks like "bloodfall")
- 13 Lift platform
- 14 Secret door which opened while you were gone
- 15 Yellow Door
- 16 Red Key
- 17 Walls raise when you get (16)
- 18 False wall
- 19 Cache of goodies
- 20 Shoot panel to open it
- 21 Secret door
- 22 Red Door
- 23 Exit

**Weapons & Ammo**

**A** box of ammo  
**BFG** BFG 9000  
**BP** backpack  
**BS** box of shells  
**BU** bullets (10)  
**CR** case of rockets  
**CS** chain saw  
**DS** combat shotgun  
 (super shotgun)  
**MG** machine gun  
 (chain gun)  
**RO** rocket  
**PR** plasma rifle  
**RL** rocket launcher  
**SS** shotgun shells (4)

lavafall and hit `[Spacebar]`. The lavafall will lower, and you will see a bunch of bad guys above you. Get on the lift and ride up. (You should still be invulnerable so don't shoot anything unless it is blocking your path, and keep running.)

Head northwest to the corridor where you entered this room. You will now see a platform coming off the ledge at the end of the corridor. Kill anything that may be on it and activate it. It will lower and you can ride it up. Once at the top run north up the corridor.

You will now notice a large opening in the right wall. As you run past this, three Revenants and several Spectres will run out. **KEEP MOVING!** Return to the room you started in and open the red door. Inside you will see the red key. As fast as you can run in, grab the key and back out. Grabbing the key will cause the west wall of this room to release enough Revenants to make a horror movie. Head south back down the corridor you just came through, with your gun blazing a path. At the south end of the corridor jump back to the floor below. By this time the room will be full of all sorts of nasties, so be careful and run like a scalded dog.

There will be a wall in front of you to the south. Follow this wall as it goes east, then south till you come to an alcove on the right. Enter the alcove and blast a hole through the three Demons you will find here. Though the back wall of the alcove looks solid, it isn't. Run through the wall and continue down the corridor till you come to a small room. In the middle of this room is a column. Shoot it and it will rise, revealing a rocket launcher. Grab the launcher. The east wall is composed of three panels. Shoot the center one, and a door will open in the east end of the south wall. Run through the opening into the room on the other side.

You will see a red door in the south wall. You will also see an Arch-Vile in an alcove to the right of the door. Get through the red door as fast as you can. On the other side will be a small room with a hole in the floor. Jump through the hole.

## **LEVEL 29: THE LIVING END**

You will be in a small room facing north. The room will have no doors. On the north end you will see a chaingun and a medikit. As you move to

## Chapter 6 Intelligence Briefings

pick them up, the north end of the room will begin to lower. When you get to the bottom you will see a commando, two Sergeants, one Imp, and a Spectre. All of you will be standing in an alcove in the south end of a large room several feet above the floor, which is covered with toxic waste. To the north you will see a large alcove with several tiers leading up to it. Be careful—you will not be able to see them, but there are bad guys up there, and they will fire at you if you give them a clear shot.

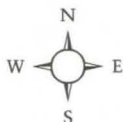
To the northwest you will see a small section of walkway around the northwest wall. On this walkway will be two Sergeants and a commando. Kill them now—it may save your life later. The alcove you are standing in contains a medikit and a switch in the southeast corner. Grab the medikit and hit the switch. This will cause a small platform to rise from the floor and connect with the northeast corner of this alcove. On this platform will be a Sergeant and green body armor.

You can walk out on this platform and go around the west wall and into a larger alcove to the west. Here you will encounter six Imps and two commandos, but you will also find a box of shells and a berserker pack. There will be a partition in the middle of the west end of this alcove. Go around the partition and kill the three commandos on the other side. To the northwest you will see a corner formed by two metal walls. In the corner will be a box of shells. Picking up the shells will cause a small section of the partition to open, revealing a switch. Go to the partition and hit the switch. This will cause the metal walls to open, releasing three Cacodemons and a Pain Elemental. The room they are in has a doorway in the northeast corner. Blast a hole through the monsters and go through the doorway.

You will find yourself on the walkway you saw earlier with the two Sergeants and commando on it. This walkway follows around the wall to the north, then curves west. Move quickly so the bad guys don't catch you. At the end of this walkway will be a transporter with an Imp and a backpack in front of it. Kill the Imp, grab the pack, and enter the transporter.

You are now in a small room facing north. In this room you will find a box of shells, two stimpacks, one medikit, a box of ammo, three health vials, and three helmets. Through the opening in the north wall you see a stairway winding along the wall to the north. To the right of the stairs you

## MISSION 29: THE LIVING END



## The Bestiary

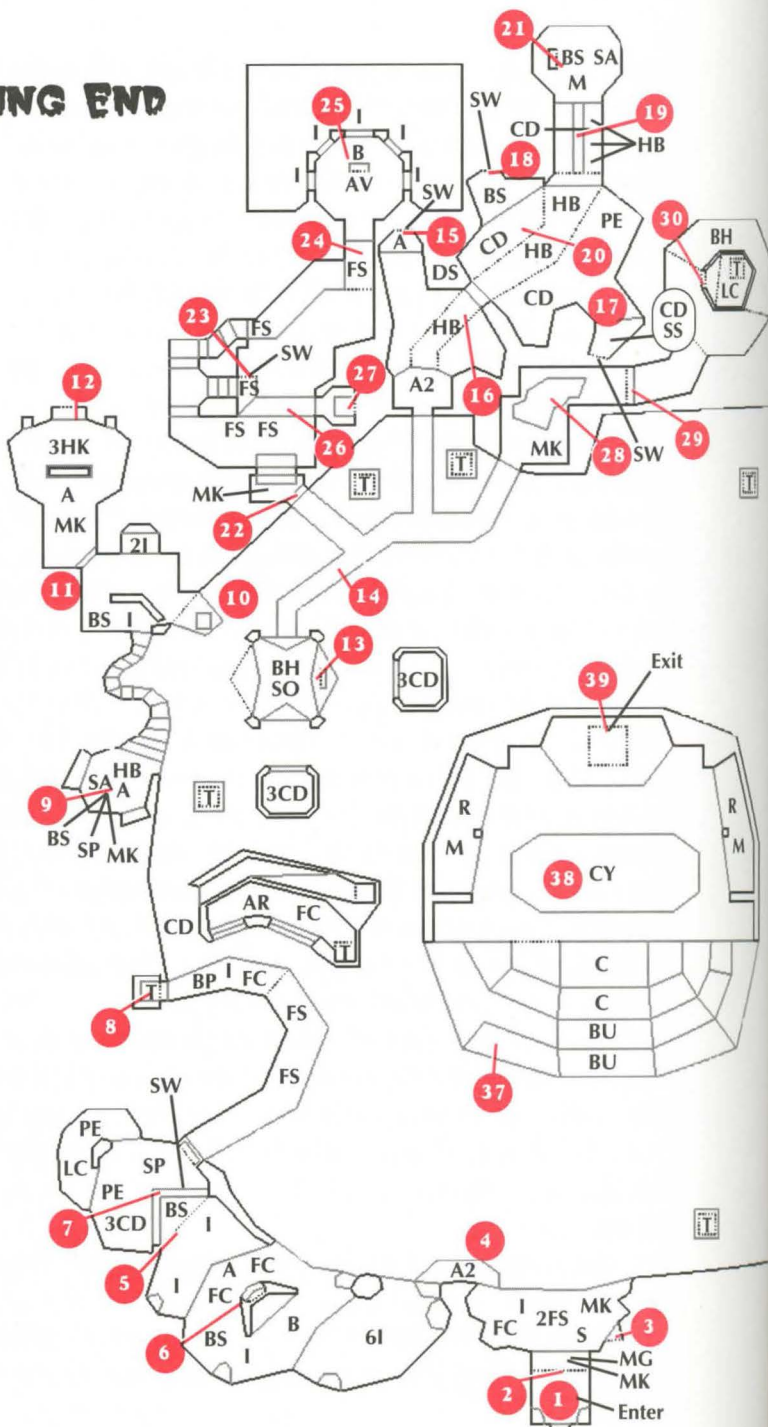
- AR** Arachnotron
- AV** Arch-Vile
- BH** Baron of Hell
- CD** Cacodemon
- CY** Cyberdemon
- FH** Former Human
- FS** Former Human Sergeant
- I** Imp
- HK** Hell Knight
- M** Mancubus
- PE** Pain Elemental
- R** Revenant
- S** Spectre

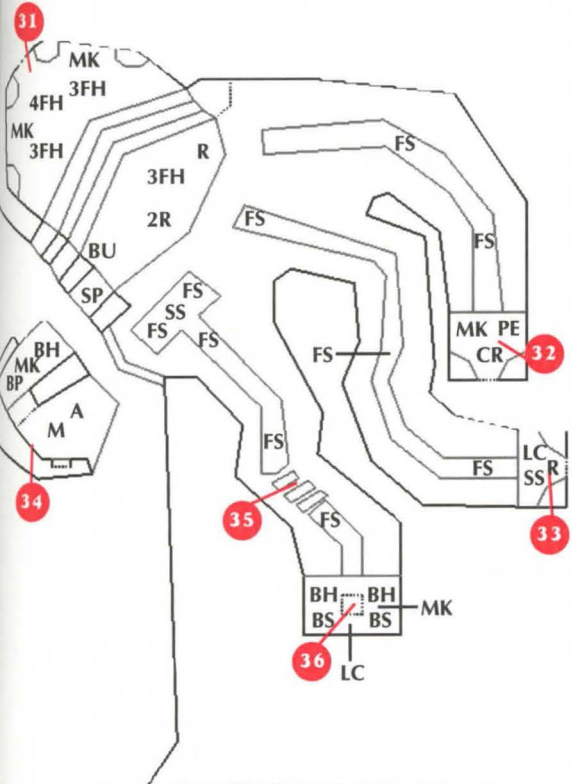
## Locations

- SW** switch
- T** transporter

## Special Items

- A2** blue armour
- B** berserker pack
- C** energy cell
- HB** health bonus (vials)
- LC** large energy cell
- MK** medikit
- SO** soul sphere
- SA** spiritual armour
- SP** stimpack





### Weapons & Ammo

- A** box of ammo
- BP** backpack
- BS** box of shells
- BU** bullets (10)
- CR** case of rockets
- DS** combat shotgun (super shotgun)
- MG** machine gun (chain gun)
- SS** shotgun shells (4)

### Waypoints

- 1 Start
- 2 Lift platform with chaingun and medikit
- 3 Switch raises (4)
- 4 Platform with green armor
- 5 Picking up rocket opens (6)
- 6 Alcove with switch that lowers (7)
- 7 Partition wall
- 8 Transporter
- 9 Where (8) takes you, lots of goodies
- 10 Box on ledge, movement here opens (11)
- 11 Secret door
- 12 Switch lowers (10)
- 13 Switch activates (14)
- 14 Walkway raises
- 15 Switch raises (16)
- 16 Walkway
- 17 Switch raises (19)
- 18 Switch raises (20)
- 19 Walkway
- 20 Walkway
- 21 Cache of goodies and switch which opens (22)
- 22 Locked door
- 23 Switch activates (24)
- 24 Lift platform
- 25 Switch raises (26)
- 26 Walkway
- 27 Switch lowers (28)
- 28 Barrier
- 29 Secret door
- 30 Secret door with teleporter and goodies
- 31 Where (30) takes you
- 32 Switch lowers section of (35)
- 33 Switch lowers section of (35)
- 34 Switch lowers section of (35)
- 35 Barricade
- 36 Teleport
- 37 Where (36) takes you
- 38 Pit with Cyberdemon, bottom raises when you get to the top of the stairs
- 39 Exit

will see a platform with an Imp on it. To the northeast you will see a tower with a Hell Knight on it. Kill both of these guys. Stay sharp—a Cacodemon will try to sneak around the east wall. Kill him and go up the stairs.

At the top of the stairs you will enter a short hallway going west. In this hall will be an Imp. Kill him and move to the end of the hall, staying close to the north wall. On the other side of the wall the hall goes back to the east. Move west, past the end of the wall but not into the hall running east. Here you will see in the north wall a barred opening behind which are two Imps. Kill these guys and slide into the hall running east. In front of you will be another Imp and a Revenant. Using the wall between the halls for cover, kill both of these guys.

At the end of the east hall you will see a doorway onto a small ledge overlooking the tower the Hell Knight was standing on. On the ledge, blocking your ability to jump to the tower, is a square block. Go back into the hall and you will see that a doorway has opened in the northeast corner. On the other side of this doorway will be a room that is wider at the north end. In the middle of the north end is a free-standing partition running east to west. Run into the room past the partition and then back up to the doorway. This will cause the three Hell Knights behind the partition to come after you. Use the doorway for cover and annihilate them. If all three do not come out, repeat the procedure till all are dead.

Now move to the other side of the partition where you will find a switch in the north wall. Hit the switch, then return to the hall. Looking east you will see that the block on the ledge has lowered into the floor. On top of the tower are a soul sphere and a switch. Get your BFG ready. Jump to the tower, grab the sphere, hit the switch, and drop off the middle of the north end of the tower.

You will land on a walkway, activated by the switch, which is slowly rising to meet the top of the tower. Turn around toward the tower. A swarm of Cacodemons is advancing toward you. Unleash the BFG and give them a taste of what human technology can do. When they are all dead, take a look around. You will see that the walkway you are on, which will now be fully raised, runs from the tower to a doorway to the northeast. Two other walkways run off between the tower and this doorway. One leads to a doorway in the northwest wall and another to a



## Chapter 6 Intelligence Briefings

doorway in the north wall. Take the walkway to the northeast wall where you will find a door with a medikit in front of it. Get the medikit and take the walkway to the door in the north wall.

Through the doorway you will be on a platform—with blue armor on it—in the south end of a small cavern. The floor of the cavern is covered in toxic waste. Move to the edge of the platform. To the north you will see a doorway above the floor and a Cacodemon in the southeast corner. Blast him, jump to the floor, and grab the rad suit behind him. In the northwest corner of the cavern is a small platform on which is a switch and a box of ammo. The switch will cause a walkway to rise from the middle of the cavern floor, running between the north doorway and the south doorway. Once it has risen you will be able to lower it with the `Spacebar` and ride it up.

Move to the doorway at the north end. On the other side you will see another doorway in the north wall. You will also see a Pain Elemental and three Cacodemons. Kill these guys and drop to the floor, which is also covered with toxic waste. There will be switches in both the northwest and southeast corners of this cavern. Activate the one in the southeast corner, then the one in the northwest. A walkway will rise from the floor of this room like the last. Move along the north wall of the northwest alcove, activate the walkway, and ride it up.

Move to the doorway at the north end. Through this doorway is a short hall. There is only a narrow walkway through this hall, and on both sides are pools of toxic waste. At the other end of the hall is a small room with a Mancubus, a switch, a box of shells, and some helmets. Kill the Mancubus from this side of the hall, enter the room, get the goods, and hit the switch.

Exit the caverns the way you came in and go back to the walkway outside and return to the doorway in the northeast wall. You will find the door here is now open, and inside you will see several Sergeants and an Imp. Kill all of them, then enter the room. Move to the southeast corner of the room and go up the stairs. There will be a landing on the second step with another stairway running up to the east. Pass this and continue up the stairs you are on. At the top a walkway runs east. It ends at the edge of the north wall, but you can look around the corner to the north and see a small room containing an Arch-Vile and a switch. Get the vil-

lain's attention and jump off the end of the walkway to the floor below. Turn to face north and fire on the Arch-Vile, moving to the left and using the wall for cover. When he is dead, turn east.

You will see a switch in the east wall. Triggering it will raise a platform from the floor, which will connect the walkway at the top of the stairs with the room the Arch-Vile was in. Go to the base of the platform and activate it. It will lower, and you can ride it up. At the top run into the room, hit the switch, and back out onto the platform.

Inside the room you could see Imps looking in through windows. One of the effects of hitting the switch is that a section of the floor below has risen, separating the north end of the room from the south. Take the walkway to the top of the stairs and go down. When you get to the landing, go up the other stairs. At the top you will see a walkway that was formed by the section of floor rising. At the end of this is a switch. Activate the switch and exit the room to the walkway outside.

Follow the walkway to the doorway in the northeast wall. This will open into a small room from which a hall runs to the east. This hall empties into an octagonal room with a large octagonal column in the center. Moving around the column will be a Baron of Hell, which will disappear and reappear in other parts of the room. Fire at the Baron of Hell, then move to the east side of the column, where you will see scratches, and hit `[Spacebar]`. The wall here will rise. Inside is a large cell, a medikit, and a transporter. Quickly grab the stuff and get on the transporter.

You are deposited in the northwest end of a new room. To the southeast will be a wide stairway leading up to another section of the room. This room is full of Former Humans and two Revenants. Southeast from the section at the top of the stairs is a lake of toxic waste with three walkways, each a few feet from and lower than the floor of the room, running to the southeast. Each of these walkways is separated from the others by walls. Blast a hole through the bad guys, run up the stairs, and jump to the walkway on the left. Move down this walkway, killing the two Sergeants in your way. At the end you will see an alcove containing a Pain Elemental, a medikit, a case of rockets, and a switch. After killing the Pain Elemental, get the stuff and hit the switch.

## Chapter 6 Intelligence Briefings

Go back along the walkway to the end. If there is anything still alive at the top of the stairs, kill it. You cannot jump back to the area at the top of the stairs, but you can see a small platform to your right. Jump to this, and you can step back onto the stairs. Go to the top and jump to the middle walkway. Go down it, killing the three Sergeants in your way. At the end you will see an alcove containing a Revenant, a large cell, and a switch. Kill the Revenant, grab the cell, and hit the switch.

Go back to the end of the walkway. You will have to jump off the walkway to the northeast and run to the platform onto which you jumped from the last walkway. Hit `[Spacebar]` and the platform will lower, allowing you to ride up. Go back to the top of the stairs and jump to the walkway on the right. On this end of the walkway will be a small platform. Turn right and through an opening in the east wall you will see a platform a few feet on the other side of the wall. On top of it are a Mancubus and a switch. Kill the Mancubus from the platform you are standing on, then jump to the one he is on. Hit the switch and jump back. You will make it back through the wall but not to the platform.

Run to the lift platform you used before. Go back to the top of the stairs and jump to the walkway on the right again. Head down the walkway. You will see that there is a gap halfway down the walkway. You will also see that there are three Barons of Hell in the alcove at the end. Kill these guys and jump the gap. In the alcove you will find a transporter, a large cell, two boxes of shells, and a medikit. Collect the stuff and get on the transporter.

You will find yourself standing on the bottom of the tiers you saw when you started this level. The tiers are actually stairs that climb east, turn back west, back to the east, and west again, where they finally reach the top. At the top is an amphitheater with a large oval pit in the center of the floor. Above the floor in the east and west walls are barred openings with a Mancubus behind each one. At the bottom of the pit is a Cyberdemon. The bottom of the pit will start to rise as soon as you step on the floor at the top of the stairs. When you get to the top, run to the north end of the room where you will find a hole in the floor. Jump into the hole.

### **MISSION 30: ICON OF SIN**

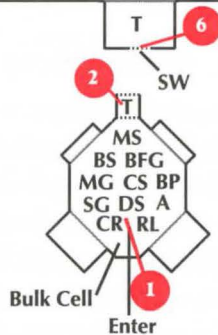
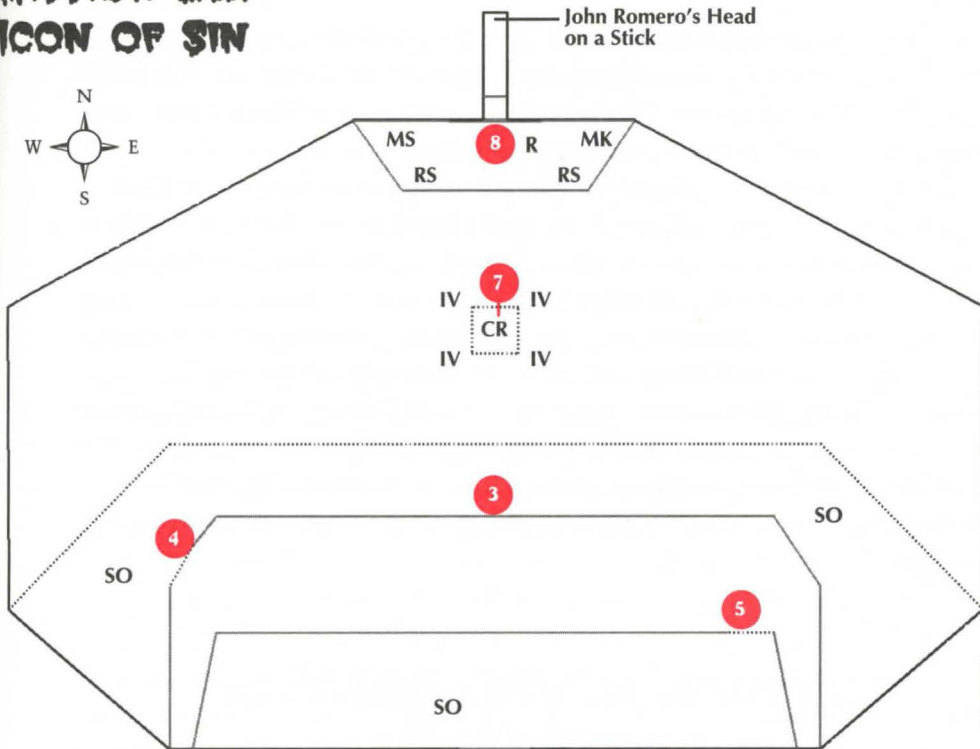
You will be facing north in a small octagonal room. In front of you will be the following: one chainsaw, one shotgun, one super shotgun, one chain-gun, one plasma rifle, one BFG 9000, one rocket launcher, one large cell, one box of shells, one box of ammo, one case of rockets, and one megasphere. Grab what you can carry and hop into the transporter in the north end of the room.

You will now find yourself standing on a ledge facing north in a large room. Across from you, two stories above the floor, is an alcove. In this alcove are two radiation suits, a berserker pack, a megasphere, and a Revenant. On the north wall you will see a huge likeness of a goat's skull with a red hole in the middle of its forehead. Small squares with skulls on each side are being fired out of the hole. When these squares hit, they turn into bad guys—anything from a Demon to an Arch-Vile. This is the Final Boss.

The floor is covered with toxic waste. On the floor between you and the north wall you will see a short platform with a case of rockets on it. As soon as you appear, turn east and run as fast as you can to the end of the ledge. Here you will find a panel in the wall to your left with a goat's skull and a pentagram on it. Activate the panel and the wall will lower. Get on and run to the west end as it is rising. Here you will find a similar panel. Activate it and this wall will lower. Get on this one and head for the opening in the center of the south wall. By the time you get there the wall will be all the way up, and you can walk into the opening.

On the back wall is a bizarre picture of a skull. Go to the center of the picture and hit **[Spacebar]**. This will cause the platform you saw on the floor to rise. Be careful—with every cube that skull pumps out you have another monster to contend with. Try to avoid them. Jump off the walls to the ledge you started on. When the platform is all the way up, jump to the floor and activate it. The platform will lower. Get on and get your rocket launcher ready. Face the center of the skull as the platform begins to rise. Watch the end of your rocket launcher. When the top of it is even with the bottom of the Final Boss's chin, fire! Your rocket will enter the opening in the Final Boss's forehead.

# MISSION 30: ICON OF SIN



## Waypoints

- 1 Start
- 2 Transporter
- 3 Where (2) takes you
- 4 Switch briefly lowers section it is on
- 5 Same as above
- 6 Switch raises (7)
- 7 Lift platform
- 8 Final boss with Revenant, rad suits, berserker pack and Megasphere

## The Bestiary

- R** Revenant  
**S** Spectre

## Locations

- SW** switch  
**T** transporter

## Special Items

- IV** invulnerability sphere  
**MK** medikit  
**MS** megasphere  
**RS** radiation suit  
**SO** soul sphere

## Weapons & Ammo

- BFG** BFG 9000  
**BP** backpack  
**BS** box of shells  
**CR** case of rockets  
**CS** chain saw  
**DS** super shotgun  
**MG** machine gun (chain gun)  
**SG** shotgun  
**SS** shotgun shells (4)

Jump from the platform to the alcove the Final Boss is in. Grab a rad suit and the megasphere and jump back to the floor. Reactivate the tower and repeat the procedure. The second rocket you put through the Boss's forehead will do him in, and you will have won.

(Note: If you turn clipping off with the cheat code provided in Appendix A, you can go behind the goat's head to a hidden room. There is no other way to access this room. Inside, in true Monty Python tradition, you will find John Romero's head on a stick. If you are playing cooperatively on a network, one player can stay in this room while the other "kills" the Final Boss. What happens is similar to the Star Wars sequence on the Destruction of the Death Star. When the rocket goes in the goat's head, it passes down a tube and strikes John Romero on the head. After the first round he screams; the second round finishes him off. Don't feel bad about that. John is definitely more happy than you are to be finished.

## **MISSION 31: WOLFENSTEIN (SECRET LEVEL)**

### **Access to the Secret Level from Level 15**

We will pick up in the room in the southwest corner of the map with the stream of toxic waste flowing through it. You have followed the stream of toxic waste through the south wall and activated the stairway in the main room. Go up the stairs to the top as before and activate the platform. At the top, after killing the guards up here, stand in the middle of the platform and face east. There will be a walkway running east and at the end turning south. Run down the walkway to the east but don't turn south—instead jump between the two crenelations in the wall. You will land on a tower in the lake of waste. On top of the tower will be a switch and a radiation suit. Grab the suit, hit the switch, and drop off the edge into the lake. Run through the lake northeast toward the wall enclosing this whole compound. At the east wall you will find an opening into a tunnel. Follow it to the end where you will find three Cacodemons and an invul-

## Chapter 6 Intelligence Briefings

nerability sphere. Kill the bad guys, grab the goods, and run back out to the lake. Run around the south side of the building in the middle of the lake to its southeast side. Here you will find a transporter, which will take you inside the building to the room where you found the BFG and the yellow key. Exit this room up the stairs to the west. You will again be on the walkway around the outside of the building. Run and jump from the walkway across the lake to the land in the southwest corner. Go back through the yellow door and follow the stream of toxic waste running through the south wall. Along this tunnel you will find a new tunnel running off to the south. Follow this tunnel to the end where you will find a transporter. This transporter will take you to the secret level.

You may remember this mission from the game *Wolfenstein*. You will be facing east in a small room. Head through the door in the east wall. You will be in a hall running north to south. There are five doors in this hall—one at the north end, two in the east wall, and two in the west wall.

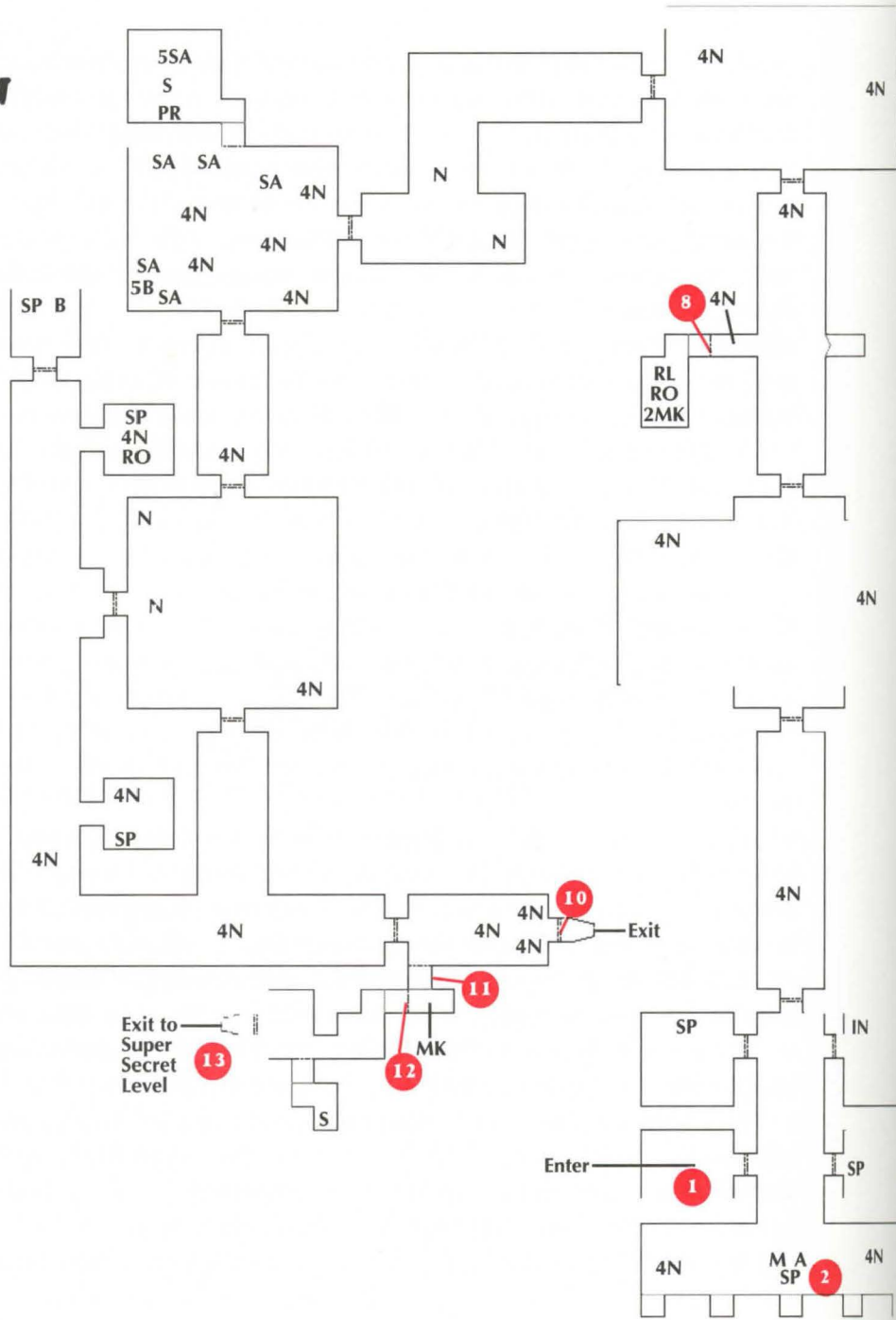
You have just walked out of the southern door in the west wall. Go to the south end of the hall. Here it will intersect with another hall running east to west. In the middle of the south wall is a chaingun. Run down, grab the chaingun, and back up. You will be set upon by two patrols composed of four Nazis each, one from the east hall and one from the west. Waste these dirt bags, then go through the door in the north end of the hall.

On the other side is a long hall with another four-man patrol. Continue north through the door at the other end of the hall. You will enter a large room. There will be two more four-man patrols, one in the northwest corner and one in the southeast corner. Kill both patrols.

You will see a door in the north wall and one in the east wall. Open the door in the east wall. On the other side four Demons are standing in a hallway running east. In the middle of this hall will be another hall running south. The Demons charge you—mow them down.

Next you see four more Nazis coming out of the hallway to the south. Blast these pukes and head down the hall to the south. At the end of this hall will be a door to the east. When you open this door you will be set upon by 10 Demons. After you have dispatched these nasties you will see that on the other side of the door is a short hall going east. There will

# MISSION 31: WOLFENSTEIN





SG  
4N  
6SS

### The Bestiary

**D** Demon  
**N** Nazi  
**M** Mancubus  
**S** Spectre

### Locations

**SW** switch  
**T** transporter

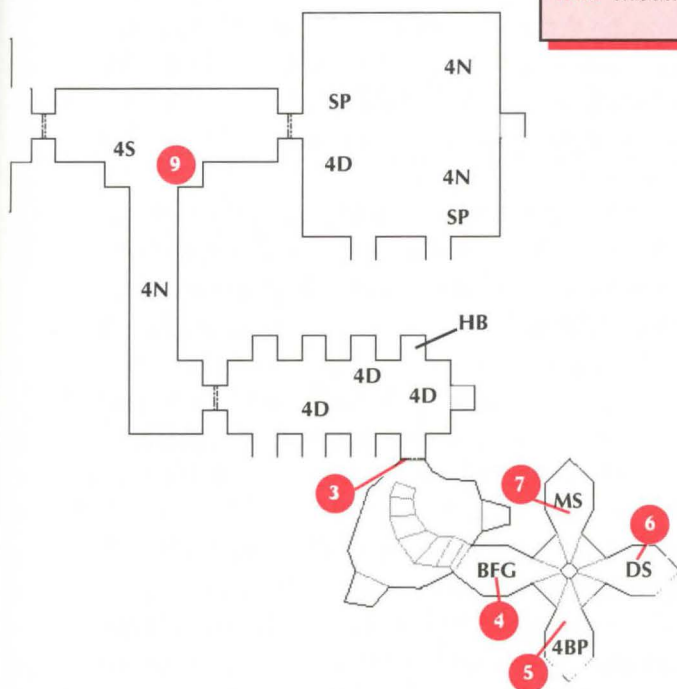
### Special Items

**B** berserker pack  
**HB** health bonus (vials)  
**IN** invisibility sphere  
**MK** medikit

**MS** megasphere  
**SA** spiritual armour  
**SP** stimpack

### Weapons & Ammo

**A** box of ammo  
**BFG** BFG 9000  
**BP** backpack  
**DS** combat shotgun (super shotgun)  
**RO** rocket  
**RL** rocket launcher  
**SG** shotgun  
**SS** shotgun shells (4)



### Waypoints

- 1 Start
- 2 Chaingun
- 3 Secret door
- 4 BFG 9000
- 5 4 Backpacks
- 6 Super shotgun
- 7 Megasphere
- 8 Secret door with goodies
- 9 16 Shotgun shells
- 10 Exit to level 17
- 11 Secret door
- 12 Secret door with soul sphere
- 13 Exit to super secret level 32

be four alcoves in the south wall and four in the north wall. Move to the easternmost alcove in the south wall. There will be a stake in front of it with five skulls on it. Go to the back of the alcove. Here you will find a secret door. When you open the door, you will see a stairway winding southeast.

Go up the stairs. At the top will be a short hall with a BFG 9000 in it. Move through this hall and out the door in the other end. In front of you will be a column surrounded by four doors. There is the door you entered from, and one each to the north, south, and east. Behind each door is a small room. The room to the north contains a megasphere, the one to the south has four backpacks, and in the one to the east is a super shotgun. Collect all these and go back down the stairs.

Reenter the hall with the alcoves and go back out the door to the west. Follow this hall north and go through the west door at the end. You will now be back in the large room where the two patrols attacked you. Go through the door in the center of the north wall. You will be in another long hall running north. At the end of the hall will be four more Nazis. Put these guys out of their misery.

You will see two alcoves in this hall, one each in the middle of the east and west walls. The alcove in the west wall conceals four more Nazis. Kill these four and go to the back of the alcove. The back wall is a secret door behind which are two medikits, a rocket launcher, and two rockets.

Go back to the hall and through the door in the north wall. You will enter another large room with two more four-man patrols. One patrol is in front of you and the other is in the southeast corner. After killing all these guys go to the door in the east wall. Behind this will be a small room housing a four-man patrol and 24 shotgun shells. Get these, go back to the last room, and go through the door in the west wall.

You will now be in a hall to the east. At the end it will turn south. Here you will run into another four-man patrol. Kill these guys and move south to the end of this room, where you will enter a room with yet another four-man patrol. Take these guys out also and exit the room through the door in the west wall.

You will be in another large room with five more patrols. One is in the center of the room and another in each of the four corners. Blast your

## Chapter 6 Intelligence Briefings

way through to the door in the south wall. Here you will find a hall running south with four Nazis at the other end. Kill these guys and move through the door in the south wall. You will be in another large room with three patrols in it. Two of the patrols will be along the east wall and the last in the northwest corner. Run through this room to the door in the south wall.

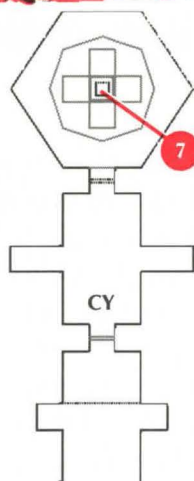
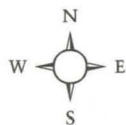
You will be in another hall running south with four Nazis at the end. Kill these guys and move to the end of the hall. At the end of this hall is another hall running east to west. Follow it to the door in the east end. Open the door and start firing. Inside is a hallway with three four-man patrols in it. In the east wall is the Exit door. Open it and find the switch behind it. Hit the switch and you are done.

### **MISSION 32: GROSSE (SUPERSECRET LEVEL)**

To get to this level you must have made it to the secret level. At the end of the secret level, in the room with the three patrols and the Exit door, go to the west end of the south wall. Here you will find a secret door. Behind it is a short hall running south, then east, with a medikit at the end. Go to the south end of the west wall. Here is another secret door. Behind this is a hall that winds around to the west, where you will see an Exit door. Open the Exit door and hit the switch on the west wall. You will now be on your way to super secret level 32.

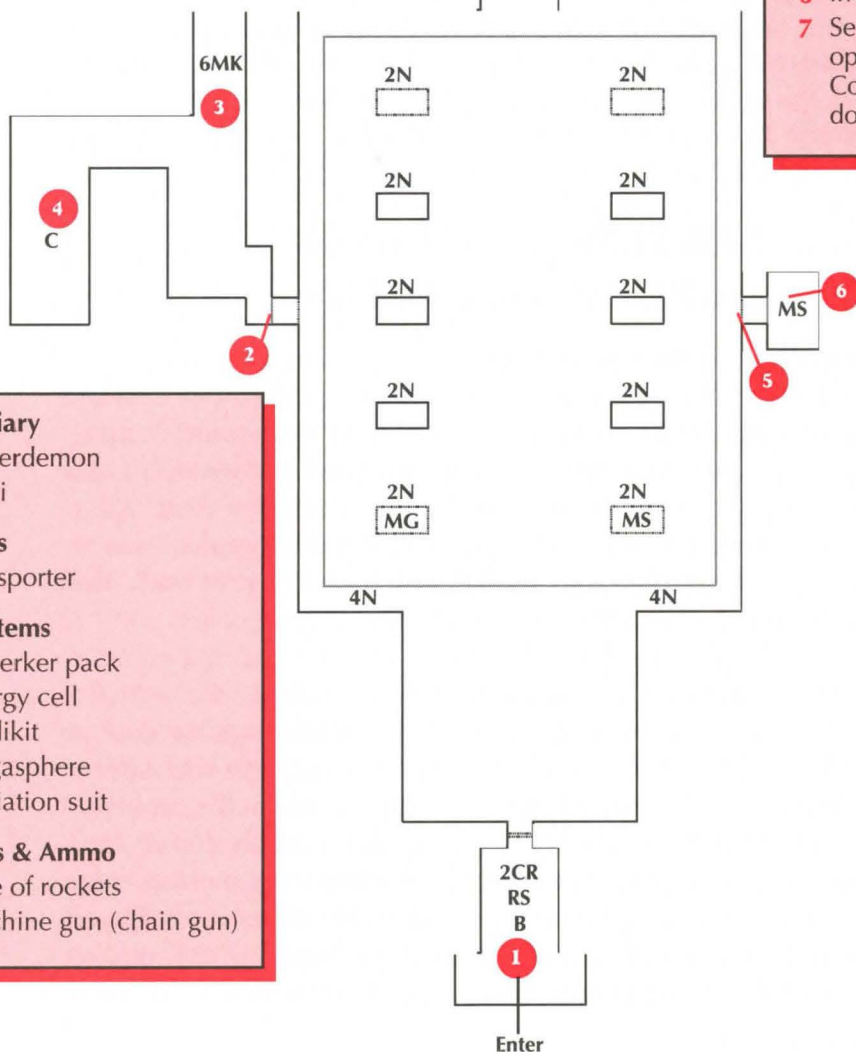
You will start in a small room facing north. In front of you is a berserker pack, a rocket launcher, and two cases of rockets. Go through the door in the north wall. You will be in a large entryway heading north into a larger room. You will see five large rectangular columns on each side of the room. Unseen by you, there are Nazis hiding on the north side of each column. Run into the room and between the second and third columns on the left. Go to the west side of the third column. Here on the west wall you will see a wreath. This is hiding a secret door. Go through the door, and you will be in a hall running north with six medikits at the end.

## MISSION 32: GROSSE



## Waypoints

- 1 Start, with rocket launcher and rockets
- 2 Secret Door
- 3 6 Medikits
- 4 Plasma rifle and 25 cells
- 5 Secret door
- 6 Invulnerability
- 7 Secret compartment opens when all Commander Keen dolls are dead. Exit



## The Bestiary

**CY** Cyberdemon

**N** Nazi

## Locations

**T** transporter

## Special Items

**B** berserker pack

**C** energy cell

**MK** medikit

**MS** megasphere

**RS** radiation suit

## Weapons &amp; Ammo

**CR** case of rockets

**MG** machine gun (chain gun)

## Chapter 6 Intelligence Briefings

In the middle of the west wall there will be a hall running to the east, at the end of which is a room containing a plasma rifle and 25 cells. Take all you can and go back through the secret door into the room with the columns. Blast the few Nazis who are left and make your way to the column in the southeast corner. Hit **[Spacebar]** and the column will lift, revealing three mini guns.

Move over to the column in the southeast corner and activate it. This one will lift, revealing a megasphere. Grab the megasphere and head for the door in the north end of this room. When you get about 10 feet from the door, it will start to rise. Immediately start backing up. Behind the door is a Cyberdemon. Move to either the east or west wall. Hide behind the columns and lure him to the south end. When he gets to the south end of the room, run for the door in the north wall using the columns for cover.

Run through the door. You will be in a short hall with a door in the north end. Run through this door. In front of you will be an octagonal hole. Suspended from the ceiling will be an X-shaped platform. *Commander Keen* hangs from each arm of the platform. Shoot all four of them till they fall, and the inside of the platform will rise. Now move to the north end of the room. You will see a switch on the north side of the platform. You will now be able to jump onto the platform and trigger the switch, which ends the level.



## CHAPTER

# 7

## MULTIPLAYER NETWORK NOTES

A large part of the *Doom* and *DOOM II* phenomena has been the interest in multiplayer mode. Gaming has been a social activity throughout history, and it has only been recently, since the introduction of home computers, that it has skewed away from its roots to become a more solitary pursuit. Modem, and now network, play have reintroduced the social roots of gaming. This is a healthy phenomenon that players are responding to, because if we are to thrive in our new electronic universe, as opposed to becoming lost in the digital ether, our base must remain in human interaction. The *Doom* games provide that much-needed grounding, hence their popularity.

## **COOPERATIVE PLAY VS. DEATHMATCH**

Expanding on the concept of human interaction, you must also realize that it comes in two flavors: positive and negative. Positive interaction centers on working together to achieve a greater objective. The whole is greater than the sum of its parts, if you will. *DOOM II* supports this need through the Cooperative Play option. Groups of players can come together and form a fire team, develop a plan, support one another, and rid the world of evil. It kind of gives you a warm fuzzy feeling deep down inside, doesn't it?

And then there are the rest of us, those who relish the darker side of human nature. We understand competition more than cooperation. And though we may or may not gloat over it, we want you to clearly understand that "you are OK, but I am better." *Doom II* also supports these human needs with its Deathmatch option. Each of the two multiplayer modes has its differences, which we will now explore.

This appendix explores the differences between the two multiplayer modes.

### **Watch My Back**

In Cooperative Play, the entire fire team enters a level at the same location. They can stick together or split up if they wish from that point forward, but unit integrity is maintained at the outset. Weapons and keys are inexhaustible items in this mode of play. If one player picks them up, they are immediately replaced so that other players can access them. Other items are *not* inexhaustible, so the fire team leader must determine who in the squad needs the item most.

In Cooperative Play, the Automap always shows the location of all players. Each arrow on the map is color coded to match the uniform of that player, either brown, indigo, green, or red. You can also switch to the first-person view of other players by cycling through with the **[F12]** key. While in this view, you will not see the other player's status bar, just your



## Chapter 7 Multiplayer Network Notes

own. Further, if the screen flashes red while your thoughts are elsewhere, it is because *you* are being hit, not them. To switch back to your own view and deal with the threat, hit any other key.

At the end of the level, each player's statistics screen will show only his own achievements, just as in single player mode. There are several new twists on the options available during play, however.

### Chat Controls

During Cooperative Play, you can chat online with other members of the fire team. To do so, you can either address one member directly by prefacing the message with the color of his uniform (**b** for brown, **i** for indigo, **g** for green, or **r** for red), or you can broadcast a message to everyone at once by pressing **[T]**, then typing your message. Although anyone can access this function, in practice, broadcast mode should be reserved for the fire team leader's use. This exclusion is to keep the comm channel from becoming cluttered at critical moments.

In addition to your own unique messages, the program also features a number of pregenerated "macros," which may be sent to others. This is a nice feature, but it doesn't really fulfill the human interaction theory. Get original. Use your imagination. Have fun with the Chat feature.

### Game Controls in Multiplayer Mode

The manner in which certain game controls function is different in multiplayer mode. For example, any player can pause the game normally from his keyboard, and all players will be affected. At the same time, however, any other player can start the action moving again by hitting the **[Pause]** key on his terminal.

Anyone can save the game for everybody at any time. Because of the limited number of game slots, however, it is a good idea to decide ahead of time who will be doing this for the fire team. Saved games cannot be restored unless everyone on the team quits the current game and returns to the Setup menu.

## **I'm Gonna Frag You!**

Deathmatch play has its own anomalies also. When you start a game in this mode, each player begins the level at a random location on the map. You cannot "spy" on others by switching to their view, as in Cooperative Play, and they will not appear on the overhead Automap either. Every player begins the level with all of the needed keys, so it is possible to access any area from the outset.

Weapons are replenished after a player grabs them, but the player can only grab that object one time. It returns simply for the use of other passing players. This precludes one player from sitting on top of a plasma rifle, for example, and having an inexhaustible supply of ammunition.

The chat and game controls are the same as in Cooperative Play. All cheat codes are disabled for both multiplayer modes. In Deathmatch, the ARMS section of your status bar is replaced with FRAG, a word whose originating stems from the Vietnam War era. Fraging someone means maiming or killing a person on your side of the conflict, generally with a fragmentation grenade. As such, this field on your status bar reflects the number of kills you have inflicted on your "brothers in arms."

Unlike their real-world counterparts, however, these victims can respawn (come back to life) in another random location several seconds after their demise. When they return, they will be stripped of any special weapons or ammo they have accumulated up to that point and must start over with only the pistol. At the end of the level, each player's statistics screen shows his death count against each of the other players.

## **Deathmatch Specific Strategies**

Speed is life. The first thing players will notice in multiplayer mode is that other humans move a helluva lot faster than their demonic counterparts. Everyone must take advantage of that speed to stay out of everyone else's field of fire. If you stand still for long, you're a goner. This means practicing fire and movement strategies, like those discussed in Chapter 5, until they are fluid and natural. Bottom line: The more experienced you are in single-player mode, the more effective you will be in Deathmatch mode.

The same statement also holds true with regard to terrain. If you are

## Chapter 7 Multiplayer Network Notes

familiar with a level from having played it extensively in single-player mode, you will know where to find the good weapon upgrades, ammunition caches, and other valuable powerups. It is very difficult to explore at the same time you are worried about three other cunning enemies crawling into your knickers unexpectedly.

Use all your senses. Listen for doors opening and closing. Try to pinpoint where gunfire is coming from and anticipate your opponent's approach. Be opportunistic. If two other players are focused on one another, snipe at both of them. Create distractions, such as opening doors or wasting a couple of ranged rounds, to make the other players think something interesting is going on, then lie in wait for them. Above all else—especially if you are playing against the same people all the time—try to avoid developing a pattern they can exploit. Be unpredictable and you will live longer.

### HOW TO PLAY ON A NETWORK

*DOOM II* supports the IPX (Novell Netware) protocol. Using this network support, the game can be played in a work environment, provided of course that your boss doesn't object. If he does, try to get him or her involved in at least one game after hours or at lunch. This tactic generally eliminates the problem.

To start network mode, launch from the SETUP program by going to the directory in which you installed the game, typing SETUP, and pressing **Enter**. Unlike single player mode, multiplayer mode must be run either from the SETUP program or by using the command line parameters. The SETUP program allows you to configure the information that is necessary for the multiplayer game and is self-explanatory. Launching from the command line is slightly more cumbersome, but it also allows you to input additional instructions that will govern the session.

- LOADGAME allows you to start *DOOM II* from a specified saved game. Instead of using the saved game name, simply enter the number (0 through 5) that corresponds to the slot you saved the game to on the SAVE GAME screen.

## DOOM II Hell on Earth

- DEATHMATCH starts *DOOM II* as a Deathmatch game. If you don't enter DEATHMATCH as a command line parameter, *DOOM II* will default to Cooperative Play mode.
- SKILL sets the skill level (1 through 5).
- CONFIG allows you to use your configuration file from any directory you choose.
- NOMONSTERS allows you to start Deathmatch without having to worry about anything except the other human opponents.
- RESPAWN tells *DOOM II* that you want all the monsters to respawn eight seconds after you kill them. The Nightmare skill level already does this.
- FAST uses fast monsters, as in Nightmare level.

If you are using an IPX network, go to the directory that contains the *DOOM II* program and type **ipxsetup**, plus any of the aforementioned command line parameters you wish to include. You must also include the **nodes** command line followed by a number from **1** to **4**, which corresponds to the number of players. The default is two players.

## CHAPTER



## INTERVIEW

John Romero's name is writ big across the world of programming right now. A scant few years ago John and the programming team he is a part of, id Software, were virtually unknown to the mainstream programming elite. If people knew them at all it was as "those shareware guys." But then they got this idea for a good 3D engine, and decided to slap it on this old game called *Wolfenstein*, and, obviously, the rest is history.

Catching up with John isn't an easy task. What with *DOOM II* and getting ready for the next Id production, *Quake*, he is more than a little busy. And, of course, there's the movie thing. Universal has started putting together the cast for the *DOOM II* movie, with Arnold Schwarzenegger in the lead if id's luck holds. But here is a transcript of a few minutes out of the busy day of the man who made the monsters, John Romero, as he talks about Id, shareware, programming, *DOOM II*, and the *Night of the Living Dead* movies.

A large, horizontal, red splatter graphic that starts as a dense, textured mass on the left and tapers off into a thin, horizontal line on the right. It is positioned at the top of the page, partially overlapping the page number and the title.

## DOOM II Hell on Earth

**Ed Dille:** *Doom* is notoriously hacker-friendly. How is that aspect of it going to fare now that the game is pay-to-play?

**John Romero:** *DOOM II* is the same. It keeps people interested in the game, and when people play all of *DOOM II* and they want more, but there isn't any more because we haven't made any more, then they can create more themselves. Plus when people play the game and think they have a neat idea, they can go ahead and create those things. *Star Wars* is the coolest [hack]. It's really cool now, and they're working on new graphics. Someone did a Mickey Mouse one. Disney is really pissed at the people who did that, too. People can create with our game—they get to have fun. They get to feel kind of like they're game designers. Which is cool for them.

**ED:** You've created a mega-popular hit with *Doom* as shareware; now you're going to put the second version through traditional distribution. Why the switch?

**JR:** We've done that with all of our products. Since id started, we've done a shareware product and then we've done a commercial version of it. Like the *Commander Keen* series. We did *Commander Keen*, which was shareware. Then we did a version that was retail-only, *Aliens Ate my Babysitter*. We did *Wolfenstein*, which was shareware. Then we did *Spear of Destiny*, which was retail-only. There is nothing new about it; people just don't seem to notice it. They associate us with shareware, which is good.

**ED:** How do you feel about shareware in general?

**JR:** Shareware is great. We get to make a game, give it away, everybody beta-tests it for us. They download it and tell us about any problems with it. Basically the shareware market is a great beta-testing market for us. We get all the bugs out, then we release a bug-free commercial product.

**ED:** Do people really register shareware?

**JR:** Yeah.

**ED:** Do you have a good registration rate on it?

**JR:** No. The ratio of the unregistered users to the registered users is like

## Chapter 8 Interview

5%. There are 100,000 registered users and like a million people playing. 100,000 is big, but it should be at least 30 percent. It's because we're giving something away for free and we're not marketing the game heavily like we should. We don't bug you in *Doom* to be registering the game. When you quit, there's a screen telling you that you should really register the game and blah blah blah, but we don't inhibit the game experience like some games do—like when you start the game and a shareware screen comes up saying, "You should register this." There's none of that stuff where you finish a level and you get the tally screen and it says, "Guess what, you need to register!" We make the player enjoy an entire game experience and we don't screw up the flow of the game by throwing up shareware messages.

**ED:** What's the first game you ever did?

**JR:** I did a game called *Dangerous Dave*, and John [Carmack] did a game called *Catacombs*, but they weren't 3D. Then we did a game called *Slordax*, then *Shadow Knights* and *Rescue Rover*. We've done lots of games—like 20 games people don't even know about. That's working together. And before we even got together, I made tons of games back in the Apple II world and John did that too. I've been doing this for 15 years.

**ED:** What is your development process?

**JR:** Totally loose. We don't ever have a design spec for a game. We all get together and say, "So what kind of game do we want to make?" We already have the technology and vision for the next game, so we know what the technology is going to be that will blow away the game we just did. Then we need to think of a setting and decide what kind of graphics we'll use. We try to get the graphics to go with the technology: What would be the best type of graphics and setting to go with this kind of technology so everything is as good as it can get? Then we think, "We have this kind of theme," so the artists start drawing what they think would look good. Then they start creating some monsters and we start creating some levels. And, of course, I have to start writing the utilities: the utility to create the world and that stuff. So we create some things and we get better with using that technology. We rework our tech from the ground up every time, just like *Ultima*. Our whole plan of doing things

has been just like *Origin's*. When they did each *Ultima* they threw everything away and rewrote it. That's why each *Ultima* was cooler than the last one. That's what we do. We don't use anything we've used before. There was one utility I used that had been used in 33 different games, but that's kind of a rare thing. In most of our games we'll write something and just throw it away, because we've got better ideas of the way we want our file structures or whatever. Like *Quake*, our next game, has nothing to do with the way the *Doom* worlds are. The data and technology are totally different. So the *Doom* editor is useless to us; our licensees use that.

*Quake* will require a totally new editor. That's going to take a long time to do. With *Quake*, there isn't even a premise yet. There's just kind of a feel for the thing. There isn't any story. . . . Well, there is kind of a vague story, but there isn't anything solid because halfway through the development of the game we'll probably have to throw it out and redo it. Because we'll have learned so much about the technology and the way the engine works and what's cool that what we did before will suck. So we'll do a lot of development for the game, then probably throw it out about halfway through. That way, when a game comes out, its great. That's how we learn and make cool games. We don't ever have a design spec where in Month Three we have to have the first three levels done, like milestones, and by the time the product's done a year later the first levels you did really suck, but you have to keep them because they're in the milestone. We never do that. We will not release a game unless it's cool. The first level of *Doom* was redone two weeks before it was released because the old one sucked. So for instance you saw the pre-beta of *Doom*, the first *Doom*, the alpha that got out on the net, and there's just a huge amount of difference between that and the final. There's so much that changed even in the last month of *Doom's* development. That's the way we design stuff. We don't stick to a design spec; there isn't any. It's just what is cool.

**ED:** You mentioned licensees. So you sell your old tools?

**JR:** Yeah, we do that. We have someone like Capstone call us and say they really want to use the *Wolfenstein* engine. We say, "Okay, fine, this is how much it costs"—say \$50,000. Then we do a \$50,000 XCOPY onto a SyQuest cartridge [a large removable storage media] and send it to



## Chapter 8 Interview

them. That's the joke around here: "It's time to do another \$50,000 XCOPY." Go ahead, have fun, here are the tools we used and everything. Basically, we give them *Wolfenstein* and they rip everything out of it and put in new stuff. So when Capstone did *Corridor 7*, they took the final *Wolfenstein* project and just tore it apart and rebuilt it. *Blake Stone*: same thing. Here's *Wolfenstein*, take it apart. It took 2 years for them to do *Blake Stone* and it took us 6 months to write *Wolfenstein*.

**ED:** Two years. What's wrong with the industry today?

**JR:** I don't know. One of the problems is that there are a lot of programmers right now and, of course, programmers are young guys and they want to get into video games. So you have a lot of these people with no history. They haven't been around the early '80s and they haven't played every game that's been out and they haven't soaked in all the ideas from the games they've played. We've played hundreds, thousands of games and we know what sucks. After playing games for two decades you figure out what is fun and what isn't. When they were playing video games they never really thought about it. We've done it for so long that we know what's cool—what we'd like to play that's not out there. We really wish we could have played a *Doom* game when we were kids, in an arcade or on a PC.

Also, the people who are out there haven't experimented with game ideas and had them fail. What they do, their experiments, get on the shelf. Back in the early '80s, all my experiments went into magazines, which didn't hurt anybody because they didn't have to type it in.

**ED:** A lot of people are making *Doom*-style games now. How do you feel about people copying your concepts and execution modes?

**JR:** We wish they would do a better job of taking our ideas. We'd really like to see some cool games based on our stuff. One of the reasons that *Doom* is cool, and a lot of people don't pay much attention to it, is the mechanics of the game. That is to say, the person who's playing the game has to have a lot of control, and it's got to feel good. A lot of people throw all these 3D engines and graphics together and don't concentrate on the input, and that's really important. That's the way the player plays the game. And a lot of games don't feel good. You move the mouse to

turn and it doesn't feel good—it doesn't feel the way you would want it to feel. We pay attention to all those little details. We spend so much time on just the movement of the character: the way he feels, going up and down, moving correctly, and feeling like you're really there. A lot of games just don't do that.

And people try on purpose to be different from *Doom* because they don't want to copy it and they come up with ideas that are just plain bad. One of the worst ideas we think you can put in a game is like in *Ultima Underworld*, where you have a cursor that moves at the top of the screen; it moves around and you point at things with it. We are all for direct control with the mouse. When you move the mouse it should move your character, not a cursor on the screen. That's one of the kinds of things that can be wrong with some games out there.

**ED:** Networks. You've popularized network games in one fell swoop. Did you know that was going to take off?

**JR:** Oh, yeah. When we were talking about it and doing it we were saying, "This is going to be the hottest game on the planet with this network." We were saying, "This is going to be the greatest network game since the history of the world." There is no game that is as cool. We knew that the network was going to be it. We play games at work all the time, and we know that people play games at work, and there are tons of networks out there. Universities—when kids are at universities they play games. But mostly, we like to play games and we thought it would be awesome at our network.

**ED:** Where did you get the par times? They seem awfully short.

**JR:** You start the level and you flip the switch as fast as you can. You don't even need to shoot anybody. You just run. The first-level par time on *Doom I* is 30 seconds and I can do it in about 12 seconds. You just run. On *DOOM II*, I did it in 8 seconds. You just run and get to the exit.

**ED:** How is id improving its game design as time goes on?

**JR:** We're trying to move our design along. *Wolfenstein* was our first 3D engine that was a big hit. We did a game called *Catacombs 3D* that was

## Chapter 8 Interview

in EGA format and it had the second 3D engine we did. The first was in a game called *Hovertank*. It was a basic filled-polygon wall. The first *Catacombs* was the first texture-mapped game we ever did, and that was in EGA. An EGA texture-mapped game! Actually, *Wolfenstein* was in EGA for a while—I had a beta of it—but we just had to drop the EGA. Anyway, *Wolfenstein* was the first game in which we had a cool 3D engine, so we tried to figure out what would be a good thing to do in it. We figured that the old *Wolfenstein* would be great, and in the first *Wolfenstein* you killed Nazis, so we took that up and did the game. And it was great. So it was really great just mowing down Nazis by the dozens. I remember rolling on the ground laughing when I first heard the Gatling Gun sound effect in the game. I'd never heard that in a game.

So when we did *Doom*, we figured, "Let's do another 3D engine—we've got better ideas for cool 3D engines. And let's make it with demons. Let's make it darker, 'cause we've got darkness and light and all that crap, and still blast stuff and find the keys and get to the exits, but this time there will be a little bit more that's involved with puzzles. With the switches, the up and down elevators, and all that kind of stuff. So there's more puzzly stuff in there. It's still a get-the-key-and-go-to-the-door kind of thing, but there's more that's involved with puzzles. Also, there's figuring out to use 3D terrain, because you've got heights now instead of just the flat *Wolfenstein* floor. So the environment has evolved and the gameplay has evolved a little bit. The main evolution was depth.

With *Quake*, we're going to move the design along further. The 3D engine has gotten to the point where it's going to be almost as much fun to experience the environment as it is to actually play the game. You should be walking around in *Quake* just in awe, looking around and going, "This looks awesome!"

And there won't be background music. In every game we've done there have always been background music and sound effects, right? The soundtrack is always there while you're playing. There will be no soundtrack. We're really going to make you feel like you're in a real world. There will be bugs and birds flying around. You'll be looking around, going, "This is great! Hey, I wonder what's over there." So you start walk-

ing over toward some forest. There will be a lot more cinematic things in the game. Of course, we'll never stop the game just for a cinematic. We never do that. What we will do, like this: Say you're walking into a forest, which looks just awesome, and all of the sounds are different, and it's dark, and to the right you see this dark cave or something. As soon as you look at that cave, something is going to happen. You'll hear some kind of low, evil kind of sound, and something will trigger, even just from your looking at this area. Maybe some red eyes will start glowing in there and maybe a growl or something. So you can take off or you can charge in there, whatever you want to do.

Of course, you'll still be able to pulverize stuff. That's just something to do and it's a lot of fun. I mean, when you play DeathMatch, it's just great blowing people away. It is just totally fun. And we think that's still really important. You get lots of feedback from it. It's a fun thing that you can't do in real life unless you want to go to jail, and it's a guy thing. So you're still gonna kill things in *Quake*, but not like in *DOOM II*. In *DOOM II*, you mow down things by the dozen. In *Quake* you'll fight, say, three monsters at the max. Probably you'll fight three guys, but it's going to be like a virtual fighter. There will be more skill involved in the fighting. You won't be holding the gun in front of you. In the games you've played before, you're still kind of distanced from the death. You're pointing the shotgun at something, you're pulling the trigger, and it shoots and the thing is dead. All you had to do was press the button—you move the mouse and press the button—and it's as easy as that. In *Quake*, you'll have to really kill things. You won't just press the trigger and hit it, you'll have to really beat the living shit out of the thing until it's dead. So you'll have this huge hammer and you'll pound it into blood paste on the floor, and you're going to have to take a while, too. You're going to have to work on it. You won't just have this arrow point-and-click kind of thing.

**ED:** Why don't we see any of your games in the arcades?

**JR:** None of the big guys have expressed enough interest in doing it, because they're working with these great post-Virtual-Fighter engines that they think are going to give them some really great games. So we're still talking to some people, but they aren't moving like they should. It would

## Chapter 8 Interview

be great, though. Like the virtual worlds, the Battletech centers—if *Doom* was in there it would just totally kill. *Quake* will be the ultimate. You are not going to believe *Quake*. *Quake* is going to be an industry when it comes out.

**ED:** [*Grunt of disbelief.*]

**JR:** It will! We're going to encourage people to start businesses based on *Quake*. We'll upload the server software for *Quake* onto the net, which means that anyone can take the *Quake* game and create a whole new game off it, a totally different game off the server software. Like a location-based center. We're going to allow people to go location-based *Quake* as much as they want. No fees. We upload the server software and if you want to start a location-based *Quake* center, do it. The only way we make money is that you have to buy the client. So let's say someone wants to start a location-based *Quake* center and they think this SGI is an awesome powerhouse server that can supply 10 nodes with no problem. So they buy this awesome SGI machine, they recompile *Quake* on the machine because we've supplied all the source code, and then the PCs are hooked to the SGIs for the playing of the game. The client—the code that runs on the PCs—the guy has to buy from us. So we just sold 10 copies of the game to this guy; that's it. We sold 10 copies of the game and we're happy. And the guy got himself a business where people come in and pay him to let them play *Quake*. It's gonna be great, we're going to let people create new games.

The game industry will really have kind of a tough time with it, because we're going to give away the ultimate game engine for free and let people create whatever they want. There won't be any licensing-the-technology thing. It will just be "Buy the client from us." There's gonna be kind of a mini-shakedown-type thing about who's going to take the *Quake* technology and create games and who isn't. I mean, why waste your own development effort when the coolest 3D engine is out there? And we'll develop another one and do the same thing.

So we'll supply you with the industry while everyone else is using it for cool stuff. And [the users] can rewrite the rules of the game—no problem—because they have the server software to create any game they

want based off it. And they have this incredible 3D universe where they can create any kind of game they want and they don't have to pay for it, except for the client, which interprets all the information being sent and does the actual 3D rendering and everything. So *Quake* will be huge when it comes out.

**ED:** [*Impressed whistle.*] How do you feel about game ratings?

**JR:** That's cool, no problem. We think that's great. We just don't think it should be done by age. It should be content-based. You know, there's a violence level of 3 and an obscene language level of 4 in this particular game. We don't think they should say, "People under 17 should not play this game." We don't think there should be an age thing on it, because some people are more mature than others. And some parents think their 4-year-olds can play *Doom* with no problem, and they can. We don't have a problem with ratings. We'll rate our games and it won't hurt us at all. If you try to take something cool away from people they just want it worse, so it doesn't hurt us at all.

**ED:** How do you feel about the creeping up of the hardware standards for games?

**JR:** We think that when people get the game, most of them should have a fun time. The people who won't have a fun time are people who we consider are going into the dark ages; they should consider upgrading. You need to look at the benchmark systems that people have—what does everyone have? Most of them have 486s. So even *Quake*, when it comes out in the fall of next year, is going to be built for a 486; it isn't going to be built for a Pentium.

**ED:** Thanks for taking the time to talk to us, John. One last question. John Romero, George Romero. . . . We have to wonder—is there any artistic link here?

**JR:** [*Laughs.*] I like all his movies. His stuff is cool! We love the *Night of the Living Dead* movies and all that stuff. That's just part of the influence.

# APPENDIX

## A

### CHEATER, CHEATER, DEMON EATER

The official Marine Corps policy is that Marines do not lie, cheat, or steal. It goes against the code of honor if they do. At the same time, however, Marines are taught that there is no substitute for victory. Win at all costs, and the Corps will probably look the other way. But if you cheat and *still* lose, there isn't a summary court martial anywhere that wouldn't laugh as they drum you out of the Corps. What you do with the material you are about to be briefed on is entirely up to you. Understand this, however, we never told it to you. If we did, we would have to kill you.

During the game, you can type the following keystroke combinations to obtain the effects or objects listed.

**DOOM II Hell on Earth**

**IDDQD:** God mode. You don't receive any special combat bonuses, but the enemies cannot harm you.

**IDBEHOLD + one of the following letters:** For powerups.

- I = Invisibility.** You become a shadowy form not unlike a Specter. Enemy attacks are much less accurate, especially ranged attacks. The effect lasts for 60 seconds.
- S = Berserk.** You shoot to 100 percent health, put your weapon away, and are consumed by a passion to rip enemies apart with your bare hands (which turns your vision red). Fortunately, this passion is also accompanied by superhuman strength. The effect lasts for the remainder of the level or until you die.
- V = Invulnerability.** You are temporarily immune to all enemy attacks and you see in inverted gray scale, like a film negative. This effect lasts for 30 seconds.
- R = Radiation suit.** You are instantly provided with a radiation suit when you can't find one just lying around. Go play in the toxic puddles all you like with this command. The duration of this effect is 60 seconds.
- A = Computer map.** This code reveals the entire map of the current level. Areas that you have not yet visited are outlined in gray. Once invoked, this bonus remains active until the end of the current level.
- L = Light amplification goggles.** Instantly provides a set of goggles that allows you to view events as if they were happening at high noon, even though they may be occurring in total darkness. This effect lasts for 120 seconds and can give you a tremendous advantage in low-light combat.

**IDKFA:** This code instantly provides full weapons and ammo of all types. It also jacks your armor rating up to 200 percent and gives you all the keys you need for the current level.



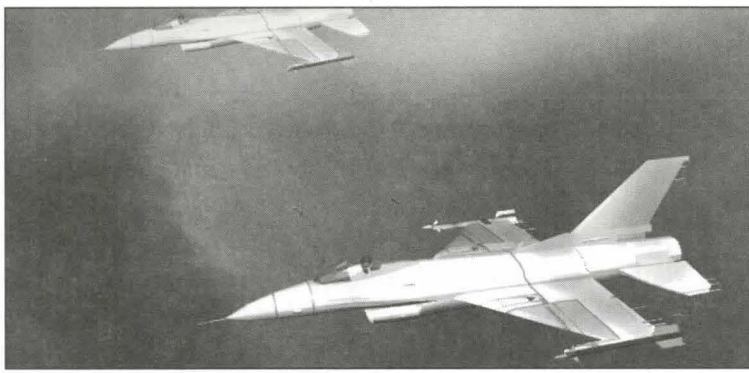
## Appendix A Cheater, Cheater, Demon Eater

**IDDT:** Invoke this code when you are viewing the Automap. The first time you use it, your map will be updated to show the entire level. Type it again and you will see the level fill up with objects, which appear as small green triangles on the overhead map. These triangles can represent items or monsters, and the latter can be living or dead.

**IDCLEV + the level number:** This code warps you to the beginning of the level number typed. Please note, however, that the numbering is sequential. For example, if you type IDCLEV04, you will go to level 4. If you type IDCLEV10, you will go to level 1.

**IDCLIP:** This turns clipping mode on and off, and you can switch between the two as much as you want. Clipping controls object collisions in the digitized environment. The default is for it to be enabled. With clipping off, you can walk through walls, jump to the top of raised platforms simply by walking into the side of them, and even wander around outside the level design. One note of caution, however, it is very easy to become disoriented if you leave clipping mode off for any length of time. It is far better to use it only if you *need* to get past a tricky platform timing puzzle or other physical obstacle that you are simply not dexterous enough to do via normal means.

**Author's Philosophical Note:** Although the use of cheat codes is a constant source of debate among game companies *and* players, the bottom line seems to be that their existence and availability to the players who need them broadens the user base of the games they appear in, not the other way around. Many players who become too frustrated to play certain challenging games will play them if they have access to guidance that helps them get past the sources of their frustration. The rest of the players and many of the game companies, who are often the vocal ones about cheats making a game too easy, are under no obligation to use them if they feel it detracts from game play.



## COMPUTER GAME BOOKS

SimEarth: The Official Strategy Guide	\$19.95
Harpoon Battlebook: The Official Strategy Guide	\$19.95
JetFighter II: The Official Strategy Guide	\$19.95
The Official LucasFilm Games Air Combat Strategies Book	\$19.95
Sid Meier's Civilization, or Rome on 640K a Day	\$19.95
Wing Commander I and II: The Ultimate Strategy Guide	\$19.95
Chuck Yeager's Air Combat Handbook	\$19.95
Ultima: The Avatar Adventures	\$19.95
A-Train: The Official Strategy Guide	\$19.95
PowerMonger: The Official Strategy Guide	\$19.95
Global Conquest: The Official Strategy Guide (with disk)	\$24.95
Falcon 3: The Official Combat Strategy Book (with disk)	\$27.95
Gunship 2000: The Official Strategy Guide	\$19.95
Dynamix Great War Planes: The Ultimate Strategy Guide	\$19.95
SimLife: The Official Strategy Guide	\$19.95
Populous: The Official Strategy Guide	\$19.95
Stunt Island: The Official Strategy Guide	\$19.95
Ultima VII and Underworld: More Avatar Adventures	\$19.95
X-Wing: The Official Strategy Guide	\$19.95
Prince of Persia: The Official Strategy Guide	\$19.95
Empire Deluxe: The Official Strategy Guide	\$19.95
F-15 Strike Eagle III: The Official Strategy Guide (with disk)	\$24.95
Lemmings: The Official Companion (with disk)	\$24.95
Secret of Mana Official Game Secrets	\$14.95
The 7th Guest: The Official Strategy Guide	\$19.95
Myst: The Official Strategy Guide	\$19.95
Return to Zork Adventurer's Guide	\$14.95
Microsoft Flight Simulator: The Official Strategy Guide	\$19.95
Strike Commander: The Official Strategy Guide	\$19.95
Might and Magic Compendium: The Authorized Strategy Guide for Games I, II, III, and IV	\$19.95
Computer Adventure Games Secrets	\$19.95
CD ROM Games Secrets, Volume 1	\$19.95
SimCity 2000: Power, Politics, and Planning	\$19.95
SSN-21 Seawolf: The Official Strategy Guide	\$19.95
Master of Orion: The Official Strategy Guide	\$19.95
Dracula Unleashed: The Official Strategy Guide & Novel	\$19.95
Doom Battlebook	\$14.95
Tie Fighter: The Official Strategy Guide	\$19.95

## NOW AVAILABLE

### VIDEO GAME BOOKS

Nintendo Games Secrets, Volumes 1, 2, 3, and 4	\$12.95	each
Nintendo Game Boy Secrets, Volumes 1 and 2	\$12.95	each
Sega Genesis Secrets, Volumes 1, 2, 3, and 4	\$12.95	each
Sega Genesis and Sega CD Secrets, Volume 5	\$12.95	
Official Sega Genesis Power Tips Book, 2nd Edition (in full color!)	\$14.95	
TurboGrafx-16 and TurboExpress Secrets, Volumes 1 and 2	\$11.95	each
Super NES Games Secrets, Volumes 1, 2, 3, and 4	\$12.95	each
Super NES Games Unauthorized Power Tips Book	\$14.95	
GamePro Presents: Nintendo Games Secrets Greatest Tips	\$11.95	
GamePro Presents: Sega Genesis Games Secrets Greatest Tips, Second Edition	\$11.95	
Game Pro Presents: Super NES Games Secrets Greatest Tips	\$11.95	
Super Mario World Game Secrets	\$12.95	
The Legend of Zelda: A Link to the Past Game Secrets	\$12.95	
Super Star Wars: The Official Strategy Guide	\$12.95	
Super Empire Strikes Back Official Game Secrets	\$12.95	
Battletoads: The Official Battlebook	\$12.95	
Parent's Guide to Video Games	\$12.95	



## TO ORDER BOOKS

Please send me the following items:

Quantity	Title	Unit Price	Total
_____	_____	\$ _____	\$ _____
_____	_____	\$ _____	\$ _____
_____	_____	\$ _____	\$ _____
_____	_____	\$ _____	\$ _____
_____	_____	\$ _____	\$ _____
_____	_____	\$ _____	\$ _____
	Subtotal		\$ _____
	7.25% SALES TAX (CALIFORNIA ONLY)		\$ _____
	SHIPPING AND HANDLING*		\$ _____
	TOTAL ORDER		\$ _____

By telephone: With Visa or MC, call (916) 632-4400  
Mon.–Fri. 9–4 PST. By mail: Just fill out the  
information below and send with your remittance to:

**PRIMA PUBLISHING**

P.O. Box 1260BK  
Rocklin, CA 95677

*Satisfaction unconditionally guaranteed*

Name \_\_\_\_\_

Address \_\_\_\_\_

City \_\_\_\_\_ State \_\_\_\_\_ ZIP \_\_\_\_\_

Visa / MC# \_\_\_\_\_ Exp. \_\_\_\_\_

Signature \_\_\_\_\_

\*\$4.00 shipping and handling charge for the first book, and 50¢ for each additional book.

















U.S. \$19.95  
CAN. \$27.95  
U.K. £18.49 NET

COMPUTER GAMES / ACTION ADVENTURE

# THE NIGHTMARE CONTINUES!

**T**HE WORLD IS ENGULFED IN FLAMES, THANKS TO ID SOFTWARE AND GT INTERACTIVE. TO AVOID AN ETERNITY OF SUFFERING, YOU MUST FIND THE DARK ONE'S POWER SOURCE AND DESTROY IT ONCE AND FOR ALL. DOOM II, WITH MORE LEVELS OF PLAY, SHARPER GRAPHICS, BIGGER AND BADDER WEAPONS, AND DOUBLE THE DEMONS, IS NOT ONLY MORE AWESOME THAN THE ORIGINAL BUT COULD DEGENERATE INTO A NEVER-ENDING NIGHTMARE. YOU COULD LOSE YOUR SOUL OR, EVEN WORSE, YOUR JOB AND YOUR FAMILY. THANK HEAVENS FOR *DOOM II: THE OFFICIAL STRATEGY GUIDE*.

THIS IS THE ONLY  
OFFICIAL STRATEGY GUIDE  
AVAILABLE AND CONTAINS  
SECRETS YOU CANNOT FIND  
ANYWHERE ELSE!

NOW, THE NIGHTMARE CAN BE CONQUERED, BECAUSE INSIDE YOU'LL FIND:

- THE UNIQUE CHEAT CODES FOR DOOM II
- WINNING COMBAT AND TACTICAL STRATEGIES TO CONQUER EVERY LEVEL AND VANQUISH EVERY IMP AND DEMON
- MAPS SHOWING ALL THE MAZES AND HIDDEN ROOMS
- CLUES FOR SOLVING THE HELLISH DOOM II PUZZLES

THIS GUIDE IS ESSENTIAL FOR ANYONE WHO IS SERIOUS ABOUT DESCENDING INTO THIS FIERY UNDERWORLD AND COMING OUT ALIVE.

**ED DILLE** IS THE SIMULATIONS EDITOR OF *ELECTRONIC GAMES* MAGAZINE AND THE AUTHOR OR CO-AUTHOR OF NUMEROUS COMPUTER AND VIDEO GAME BOOKS, INCLUDING *MAXIMUM CARNAGE OFFICIAL GAME SECRETS*, *BATTLECRUISER: 3000AD-OFFICIAL GALCOM TECHNICAL PAPERS*, *HARPOON II: THE OFFICIAL STRATEGY GUIDE*, AND *ARMORED FIST: THE OFFICIAL STRATEGY GUIDE* (ALL FROM PRIMA).

PLATFORM: IBM PC AND COMPATIBLES, CD-ROM

  
SECRETS OF THE GAMES  
AN IMPRINT OF PRIMA PUBLISHING

ISBN 1-55958-711-3

51995



9 781559 587112

EAN