

OFFICIAL STELLAR PATROL
MAP DISBURSAL AUTHORIZATION
APPROVAL FORM SM-64-K



Please review, sign to approve, then pass on
to next individual on list.

Grand Fleet HyperAdmiral *Kalman T. Troop*
HyperAdmiral *Buckley Palace*
Admiral *Stella K. Troll*
Commander *Trip Flagstone*

Return to Deck Five Map Disbursal Center.

CONFIDENTIAL: FOR ALL YOUR EYES ONLY

Map Disbursal Authorization Form XR-01-B

CANARY: Issuee

BLUE: Issuer

GREEN: Issuee's Cmdr.

WHITE: Issuer's Cmdr.

PINK: Files

BUFF: Backup Files

GRAY: Dbl Bckp Files

COFFEE: Tpl Bckp Files

CREAM: Records Officer

IVORY: Asst. Rec. Ofcr.

EGG: Jr. Rec. Ofcr.

MAUVE: Form Ombudsman

Issued: 4.12.11349 8625

Issuee's Rank: (date) LT. FIRST CLASS (time)

Issuee's Patrol ID number: 1451-352-716

Applicable Map Disbursal Center: DECK FIVE

Instructions to issuee: You are authorized to obtain copies of the maps listed below. This form should be presented at the indicated Map Disbursal Center within 18 hours of the date and time listed above. If you are unable to obtain the indicated maps within the specified amount of time, return this form to its issuer along with twelve completed copies of Inability to Obtain Authorized Maps Form UJ-47-P. At the indicated Map Disbursal Center, this form should be presented to any party or parties thereabouts responsible for the disbursal of maps, or, if the disbursal center is automated, to the appropriate automated system or systems.

Instructions to Map Disbursal Officer: The following maps may be disbursed to the issuee of this form for such purposes as are specified under the Stellar Patrol Omnibus Map Use Policies and Procedures Book. Copies of this form should be sent to the issuee's immediate superior, the ship's Records Officers, the Stellar Patrol Security Council, Archives One, Two, Three, and Four, the issuee's permanent record file, and the permanent files of the indicated Map Disbursal Center.

Instructions to Map Authorization Officer: List below the maps to be discharged to the issuee. Fill in every space. If fewer than twenty maps are to be disbursed, strike out the unused spaces to avoid unauthorized disbursals. If more than twenty maps are required, use additional forms.

1. 86273. SS - LEVEL FIVE, SCIENTIFIC SUB-MODULE, VILLAGE
2. 49501. SS - LEVEL SEVEN
3. 97624. SS - LEVEL FOUR
4. 80726. SS - LEVEL SIX
5. 11351. SS - LEVEL THREE
6. 73696. PS - ABOARD THE S.P.S. DUFFY
7. 48700. SS - LEVEL ONE, ENDGAME
8. 25641. SS - LEVEL TWO
9. _____
10. _____
11. _____
12. _____
13. _____
14. _____
15. _____
16. _____
17. _____
18. _____
19. _____
20. _____

This form is printed and disbursed entirely for the uses and purposes of the Stellar Patrol of the Third Galactic Union and may only be used for those express uses and purposes or for any other use and purpose with which the user may be instructed to comply by an authorized disburser of this form or by any commanding officer, provided that such use is in a manner complying with the rules and regulations of the Stellar Patrol and the laws of the Third Galactic Union, unless superseded by any local laws and customs where such local laws and customs apply under the Supremacy Conventions of the Patrol, the Union, or such other parties as the uses of this form may dictate. In addition and furthermore, the use of this form in no way expresses any license bestowed upon the printer, the disburser, the user, or on anyone or any party to accept or use this form or any of its parts. This form is regulated by all pertaining regulations as codified in the Stellar Patrol Omnibus Form and Paperwork Policy Book, as published on 5/15/11359 and amended on four hundred and thirty-seven subsequent occasions, and is considered a legally-binding document in a court of law or in a court of basketball or any other court you can think of. This form was designed and printed under the auspices of the Stellar Patrol Forest Planet Management and Printing Offices, or maybe it was the Printing Planet and Forest Management Offices, or perhaps the Florist Plants and Painted Manacled Officers! Does anyone really give a hoot? Does anyone who isn't really insane read this far into the fine print? I mean, you have to be really off your rocker batty nutso to even get halfway through the second line! Imagine what's it's like for a poor Ensign Fourth Class, having to write ream after ream of this trot day after day, month after month, year after kripping year! It's enough to turn your brain to guacamole! No, wait! It's worse than that! It's enough to turn your brain to quivering Gishenite jello-puddles!! Aaarrrrggh!!!!



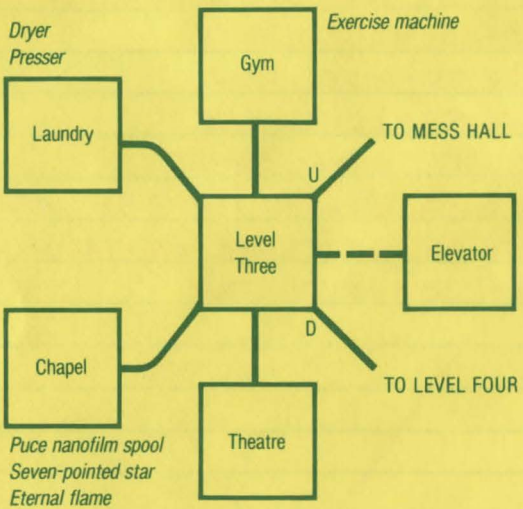

*Dryer
Presser*

Exercise machine

*Puce nanofilm spool
Seven-pointed star
Eternal flame*

LEVEL THREE

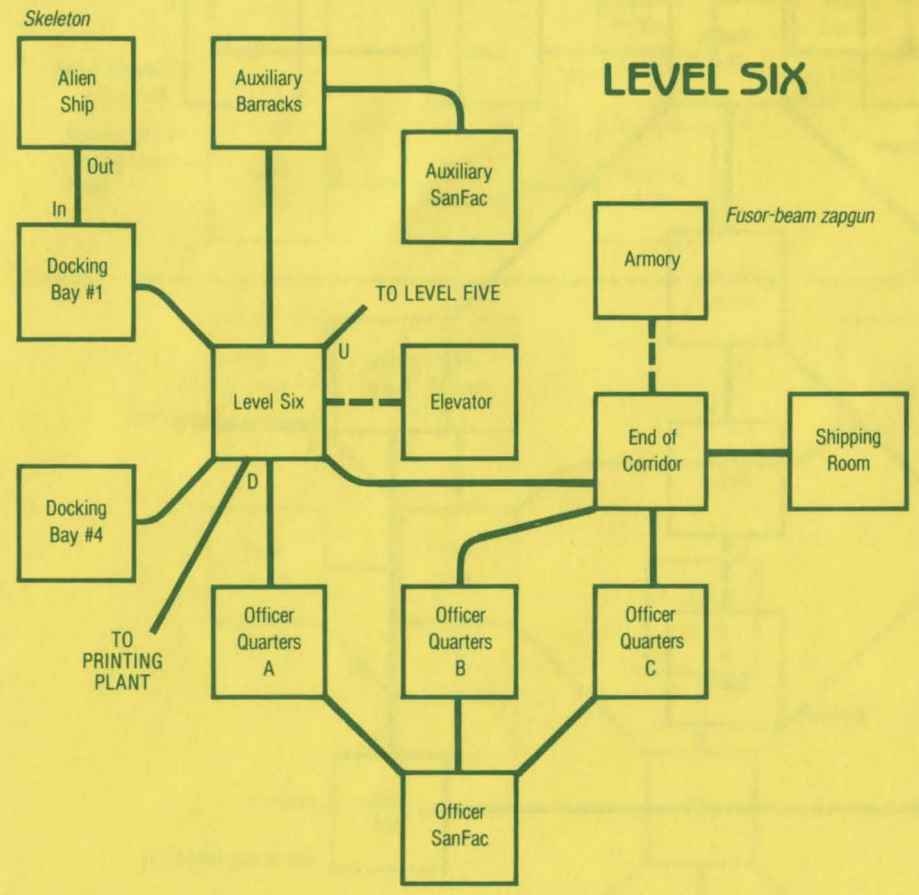

LEVEL SIX

Fusor-beam zapgun

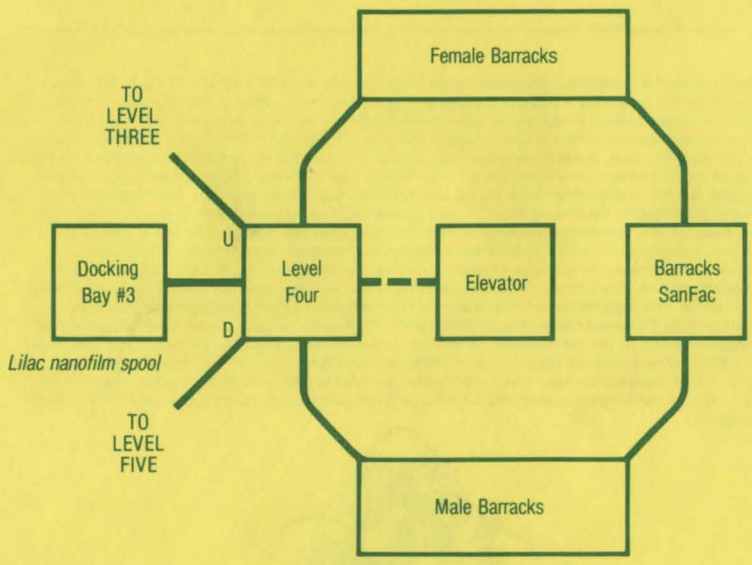

TO LEVEL THREE

Lilac nanofilm spool

TO LEVEL FIVE

LEVEL FOUR

*Drill
Small drill bit*



*Trash can
Mauve nanofilm spool*

TO LEVEL SIX

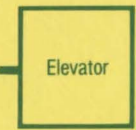

LEVEL SEVEN

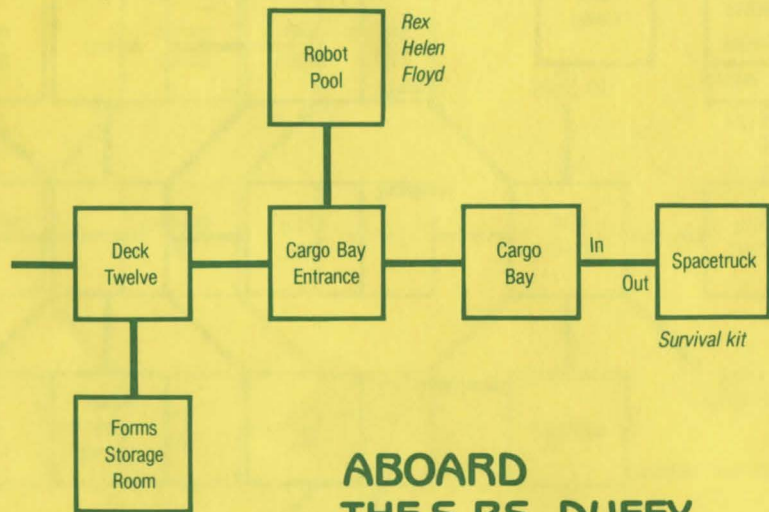

**ABOARD
THE S.P.S. DUFFY**

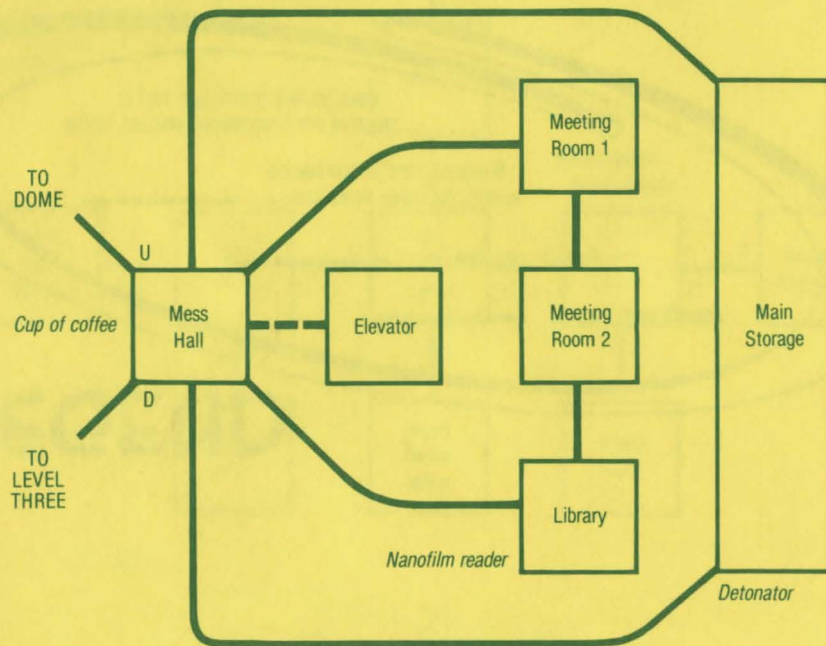

LEVEL TWO

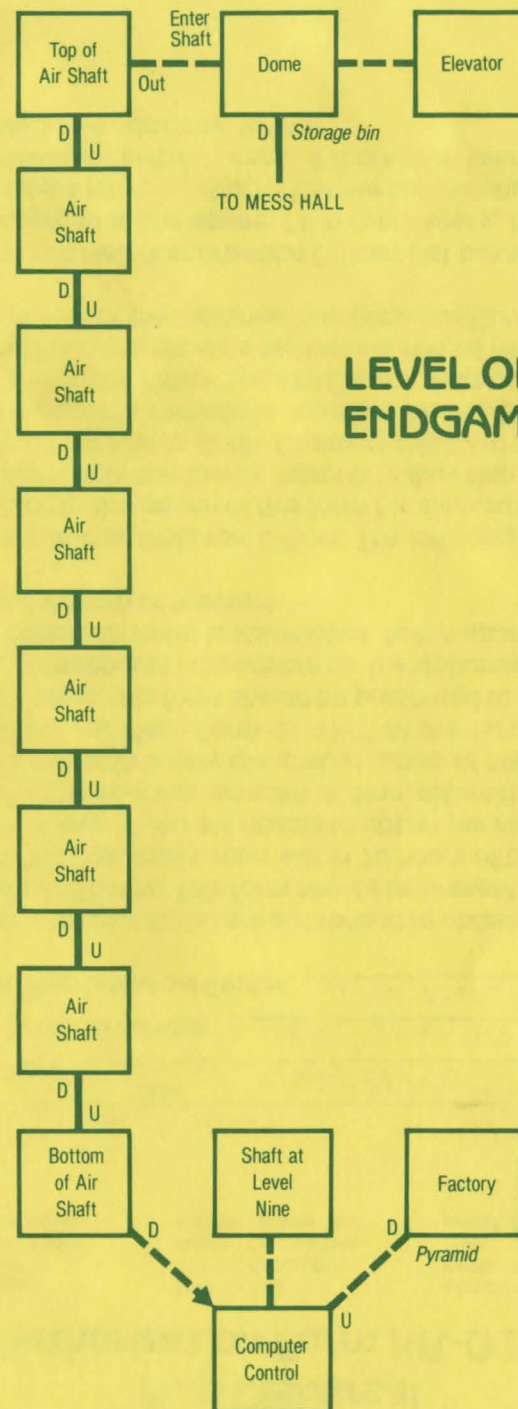

**LEVEL ONE,
ENDGAME**

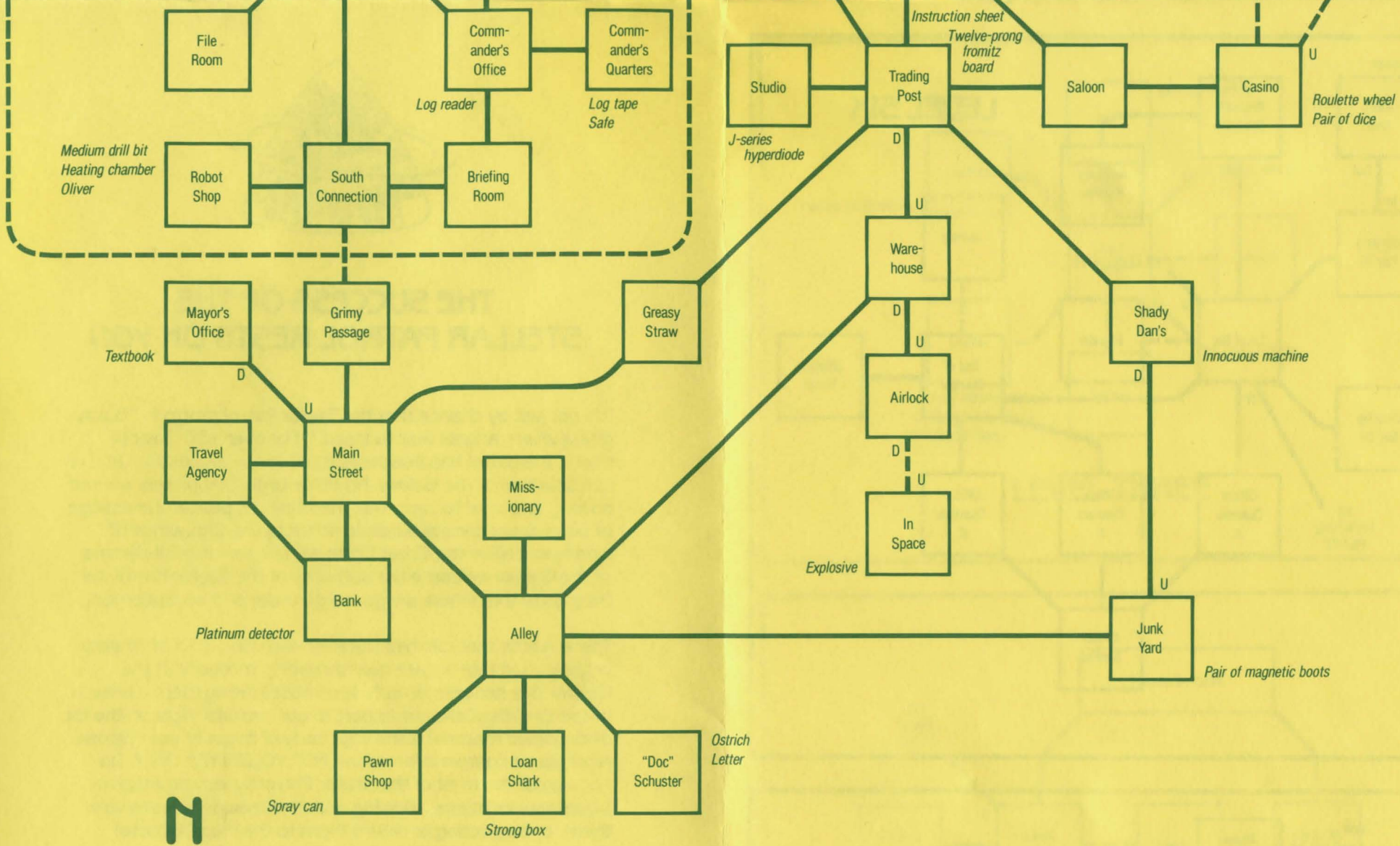

LEVEL FIVE, SCIENTIFIC SUB-MODULE, VILLAGE



THE SUCCESS OF THE STELLAR PATROL RESTS ON YOU

It's not just by chance that the Stellar Patrol motto is "Boldly going where angels fear to tread." For over 150 Galactic years, the patrol has dedicated itself to the exploration and reconstruction of the Galaxy. No other organization has worked so long and hard to carry the Third Union's peaceful message of benevolent central bureaucratism to the thousands of worlds lost after the Great Collapse. Life forms in all corners of the Galaxy welcome the authority of the Stellar Patrol, for they know that where we go, so go order and advancement.

There is little that can halt the ever-widening aura of healthy organization that we are now spreading throughout the Galaxy. But dangers do lurk, foremost among them a breach of the confidentiality we impart to our recruits. High on the list of classified material is the vast body of maps at our disposal. All of these contain information **FOR YOUR EYES ONLY**. Do not violate the trust of the Stellar Patrol by leaving maps in accessible locations, allowing unauthorized persons to view them, or neglecting to return them to the Map Disbursal Center upon completion of your assignment.

The success of the Stellar Patrol rests on the merits of our recruits. For six generations, you have made us proud. We trust that you will continue to do so.

INFOCOM™

125 CambridgePark Drive, Cambridge, MA 02140

STATIONFALL is a trademark
of Infocom, Inc.

© 1987 Infocom, Inc.
Printed in U.S.A.

1 2 3 4 5 6 7 8— 91 90 89 88 87

HB-156-MAP