

HINTS, MAPS, AND
SOLUTIONS TO

COMPUTER ADVENTURE GAMES

M. K. SIMON



From *Beyond Zork*
and *Police Quest*
to *Star Trek* and
Twilight's Ransom,
an expert's guide
to 22 popular
adventure games

COMPUTE! Books

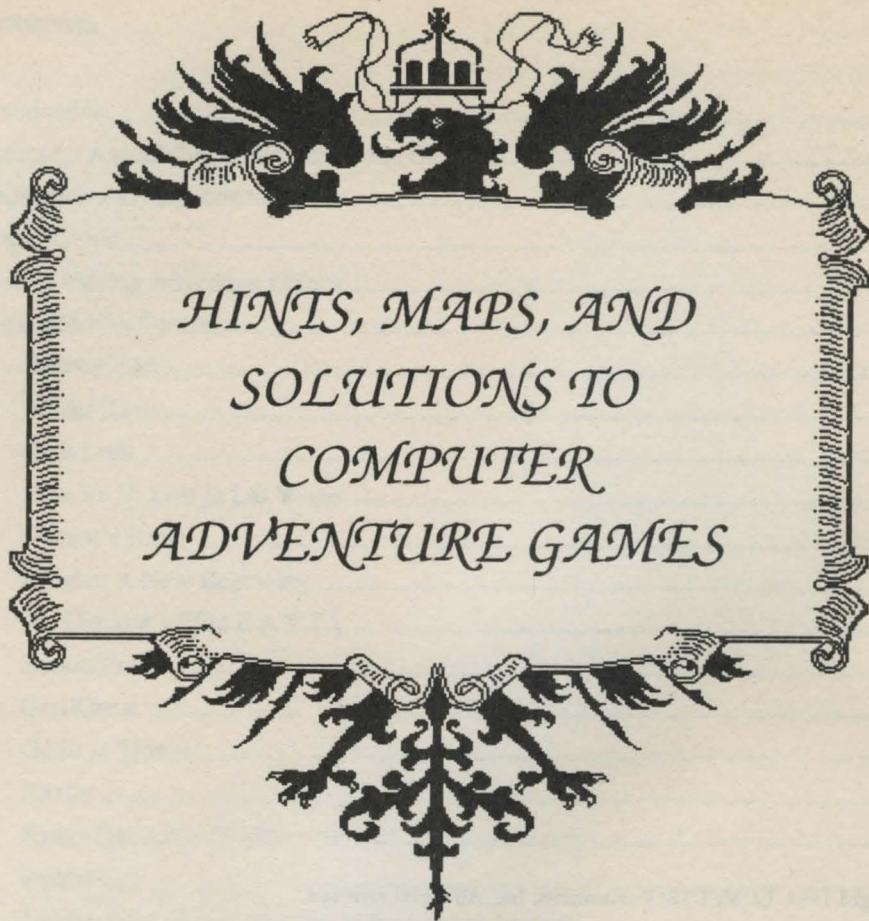

*HINTS, MAPS, AND
SOLUTIONS TO
COMPUTER
ADVENTURE GAMES*

*by
M.K. Simon*

COMPUTE! Books
Radnor, Pennsylvania

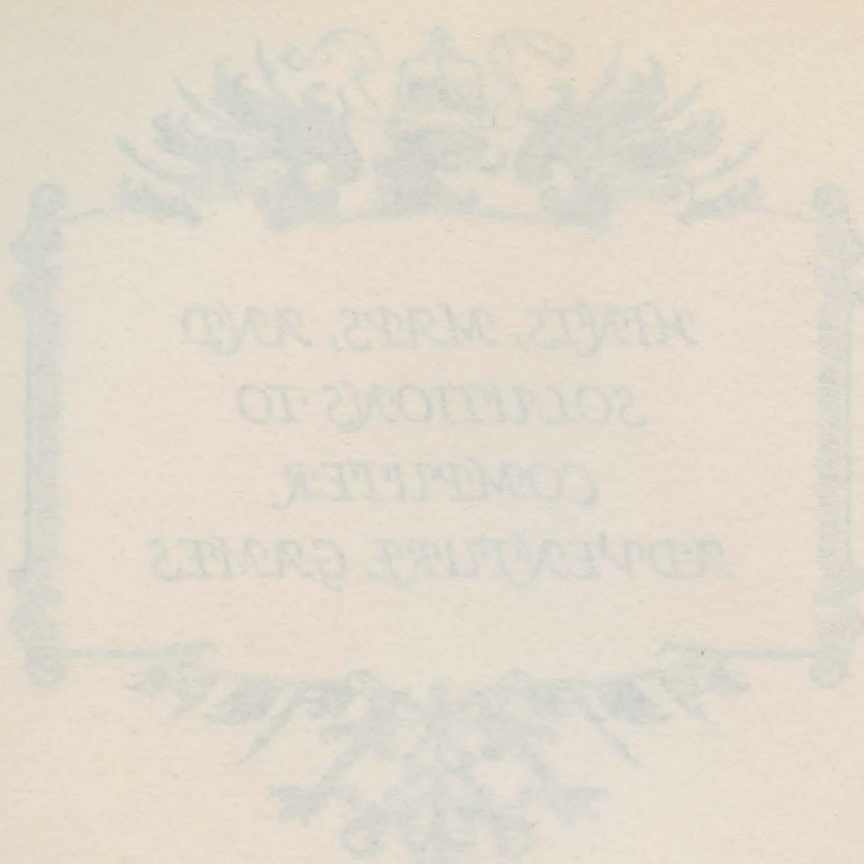

Copyright 1989, COMPUTE! Publications, Inc. All rights reserved.

Reproduction or translation of any part of this work beyond that permitted by Sections 107 and 108 of the United States Copyright Act without the permission of the copyright owner is unlawful.

Printed in the United States of America

10 9 8 7 6 5 4 3 2 1

ISBN 0-87455-220-6

LC #89-42905

The author and publisher have made every effort in the preparation of this book to insure the accuracy of the information. However, the information in this book are sold without warranty, either express or implied. Neither the author nor COMPUTE! Publications, Inc. will be liable for any damages caused or alleged to be caused directly, indirectly, incidentally, or consequentially by the programs or information in this book.

The opinions expressed in this book are solely those of the author and are not necessarily those of COMPUTE! Publications, Inc.

COMPUTE! Publications, Inc., Post Office Box 5406, Greensboro, NC 27403, (919) 275-9809, is a Capital Cities/ABC, Inc. company and is not associated with any manufacturer of personal computers.

Contents

Introduction	v
Computer Availability of the Adventure Games	ix
Dedication and Acknowledgments	xi
User's Guide.....	xiii
Tips on Playing Adventure Games	xvii
Maps and Hint Sheets	1
Beyond Zork	2
Border Zone	16
Dark Lord	21
Deja Vu II: Lost in Las Vegas	25
Demon's Forge	28
Dondra: A New Beginning	31
Dr. Dumont's Wild P.A.R.T.I.	34
Dream Zone	40
GrailQuest	44
Guild of Thieves	48
Jinxter	52
King's Quest III: To Heir is Human	57
Knight Orc	61
Leisure Suit Larry: The Land of the Lounge Lizards	68
Plundered Hearts	70
Police Quest	73
Shadows of Mordor	76
Sherlock Holmes: Riddle of the Crown Jewels	81
Space Quest II: Vohaul's Revenge	85
Star Trek: The Promethean Prophecy	90
Talisman	93
Twilight's Ransom	96

Master List of Clues	107
Complete Solutions and/or Other Information	157
Beyond Zork	158
Border Zone	160
Dark Lord	164
Deja Vu II: Lost in Las Vegas	168
Demon's Forge	173
Dondra: A New Beginning	177
Dr. Dumont's Wild P.A.R.T.I.	181
Dream Zone	189
GrailQuest.....	196
Guild of Thieves	205
Jinxter	216
King's Quest III: To Heir is Human	227
Knight Orc	228
Leisure Suit Larry: The Land of the Lounge Lizards	238
Plundered Hearts	242
Police Quest	247
Shadows of Mordor	260
Sherlock Holmes: Riddle of the Crown Jewels	264
Space Quest II: Vohaul's Revenge	272
Star Trek: The Promethean Prophecy	281
Talisman	287
Twilight's Ransom	293
Vendors	301

Introduction

Over the years, people have been intrigued by the mystery of the unknown. Such is the *art of adventure*. Here, people play the part of: 1) explorers in search of truth, wisdom, or material objects, 2) detectives in search of the solution to a murder case, or simply 3) valiant warriors in search of beloved damsels in distress.

The advent of the personal computer has allowed these real life scenarios to be brought to the computer screen in the form of adventure games suitable for play by young and old alike. This book is addressed to the myriad of computer adventurers who, like myself, spend endless hours in front of the monitor trying to answer such puzzling questions as: Where do I find the golden key that opens the dungeon door? What do I do with the chalice now that I have found it? How do I pry open the crypt? and so on.

No doubt by now all of you adventurers have experienced the frustrating feeling I am trying to convey yet have been at a loss as to where to look for a clue to get unstuck and go on with the game. Such is the purpose of this book: a place where you can get maps and hints for playing currently popular adventure games with emphasis on the word "current." Most of us who have been playing adventure games for a while have no doubt solved such classics as Infocom's Zork I, II, III series. If not, hints for solving these and other popular games of the past are available in a variety of computer magazines and publications, the most notable being this author's Books I and II of *Keys to Solving Computer Adventure Games* published by Prentice-Hall, Inc. and Kim Schuette's Volumes I and II of the *Book of Adventure Games* published by Arrays Inc. Thus, rather than repeat "ancient history," this book is devoted to "new" adventure games that have recently come on the market for which hints and clues are, to a large extent, not readily available elsewhere in collective form.

Quite often I have found, particularly with the neophyte adventurer, that even a good set of hints and clues is not sufficient for him or her to completely solve the game. Thus, a book that contained *only* such information would not have universal appeal. To service the needs of adventure players of *all* skill levels, *Hints, Maps, and Solutions to Computer Adventure Games* also includes complete step-by-step solutions for many of the adven-

ture games. The reader of this book is cautioned, however, to use these complete solutions only as a last resort since a large part of the fun of playing the game is figuring out the solution to the various puzzles on your own.

The complete solutions also serve another purpose. After finishing the game (assuming you did so using just the hints and maps), perhaps you had some questions as to why certain actions you took produced the results they did. To help in this regard, the parenthetical expressions in the commands of the step-by-step solutions attempt to provide a more complete understanding of the game storyline. Also, in certain games, a specific sequence is essential to solving a particular puzzle. In these instances, a simple hint may not be sufficient to provide the answer. Here again the complete solution will prove invaluable.

Historically, the first adventure, an all-text game appropriately titled *Adventure*, was developed in the 1960's on a mainframe. Since its first translation into BASIC language for the Apple computer in early 1980, there have been at least five different versions of this game that have hit the market (including both commercial and public domain versions). Early games like *Adventure* were characterized by a two-word (verb-noun) command parser and an extremely limited vocabulary (on the order of 50 to 100 words). These limitations made the game difficult to play since indeed one often had to type in the *exact* combination of two words in order to get a favorable response from the computer.

Since that time, adventure games have significantly advanced in two directions. First, most of the all-text types now recognize full sentences, multiple commands, and have vocabularies on the order of 1500 to 2000 words! Second, many adventure game manufacturers now offer a mixture of graphics and text in many different formats which many adventure game players find a desirable feature. The first such kind of game was On-Line's (now Sierra On-Line) *Mystery House* which appeared in late 1981. While indeed its graphics were quite elementary by today's standards (essentially isometric line drawings with no color, fill, or detail), the game represented a milestone from which the industry has moved on to an extreme level of sophistication (for example double hi-res graphics with full exploitation of the color and sound capabilities of the computer).

Contained within this book are maps, hints, and solutions for 22 of the newest adventure games currently on the market. Seven of the games are predominantly of the all-text variety while the remaining 16 are of the graphics/text type¹. Among the former are adventures based on: 1) a sultry romance aimed at women (Infocom's *Plundered Hearts*), 2) best-selling books such as J. R. R. Tolkien's *Lord of the Rings* trilogy which contains a set of beloved children's hobbit tales, and Addison-Wesley's *Shadows of Mordor*, 3) a popular TV series (Simon & Schuster's *Star Trek: The Promethean Prophecy*) dealing with the lost adventures of the starship Enterprise, and 4) a classic detective character (Infocom's *Sherlock: Riddle of the Crown Jewels*). Included in the mixed graphics/text group are: 1) a sequel to the space-age addition to the *King's Quest* series (Sierra On-Line's *Space Quest II: Vohaul's Revenge*) as well as another addition to the *King's Quest* series itself, *King's Quest III: To Heir is Human*, 2) yet another addition to the *King's Quest* series (Sierra On-Line's *Police Quest*) written by a policeman based upon his actual experiences in carrying out his day-to-day duties, 3) an exciting sequel (*Deja Vu II: Lost in Las Vegas*) to the first adventure game in Mindscape's popular series, 4) an adventure beyond your wildest dreams (Baudville's *Dream Zone*), the first adventure to fully exploit the graphics and sound capabilities of the Apple IIGS, and 5) a quest into the mystical world of MicroIllusions' *Dondra: A New Beginning*² to search for an ancient piece of a master staff that will help rid the universe of the evil Colnar. The graphics in *Dondra* are of superior quality, having been created by the graphic artist responsible for such great adventures of the past as *Masquerade*, *Lucifer's Realm*, *Fractured Faebles*, and *The Institute*.

All of the games discussed in this collection are available for the Apple II and/or Macintosh series of computers, and the maps, hints, and complete solutions have been compiled by myself from data obtained by playing each of these games to completion on an Apple IIe or Macintosh SE. I hasten to add, however, that just about all of these very

¹ Some of the graphics/text adventures are text only on the Apple IIe computer.

² This game was originally released by Spectrum Holobyte.

same games are playable and have the identical solution on IBM PC, Commodore 64/128, Atari 400/800 XL/XE and 520ST, and Amiga computers (a complete tabulation of this availability is given in Table 1). Thus, the book is in no way limited only to Apple users.

In principle, *Hints, Maps, and Solutions to Computer Adventure Games* resembles the two volumes of *Keys to Solving Computer Adventure Games*. As such, the set of clues for each of the games has been *scrambled*. This has been done to prevent the player from catching a glimpse of the clue following the one he or she is currently interested in, thus continually spoiling the surprise. Furthermore, as previously mentioned, a section devoted to complete walk-throughs has been included as an added attraction.

Table 1. Computer Availability of the Adventure Games

<u>Name of Game</u>	<u>Computer</u>								
	Apple II Series	IBM PC	Macintosh Series	Commodore 64/128	Amiga XL/XE	Atari	Atari ST	DEC	TI Prof
Beyond Zork	X*	X&	X	X#	X		X		
Border Zone	X	X	X	X					
Dark Lord	X			X					
Deja Vu II			X						
Demon's Forge	X	X							
Dondra	X			X					
Dr. Dumont's Wild P.A.R.T.I.		X	X						
Dream Zone	X@	X			X		X		
GrailQuest			X						
Guild of Thieves	X%	X	X	X	X		X		
Jinxter	X%	X	X	X	X		X		
King's Quest III	X*	X&	X		X		X		
Knight Orc	X%	X	X	X	X		X		
Leisure Suit Larry	X*	X&	X						
Plundered Hearts	X	X	X	X	X	X	X	X	X
Police Quest	X*	X&	X						
Shadows of Mordor	X	X	X	X					

Name of GameComputer

	Apple II Series	IBM PC	Macintosh Series	Commodore 64/128	Amiga XL/XE	Atari	Atari ST	DEC	TI Prof
Sherlock	X	X	X	X	X		X		
Space Quest II	X*	X&	X				X		
Star Trek	X	X		X					
Talisman	X*	X&							
Twilight's Ransom			X				X		

@ Apple IIGS only

* Apple IIe/IIc (w/128k) only

Commodore 128 only

% Apple II version does not contain graphics

& 256K required

Dedication and Acknowledgments

Hints, Maps, and Solutions to Computer Adventure Games is dedicated to my wife and children who so often woke up in the middle of the night, found me sitting in my dungeon dazed in front of the computer, and knew enough to just retrace their bread crumbs and go back to sleep.

A special word of thanks to Jerry Jones whose efforts were invaluable in the design, layout, and production of the manuscript.

Finally, I would like to express my appreciation to ImageWorld Inc., Eugene, Oregon for granting me permission to use, in the preparation of the title pages, two of their exquisite graphic images - namely Scrolls and Medieval from the "Borders & Frames" diskette of the MacMemories™ Series Blue Ribbon Collection.

User's Guide

The contents of *Hints, Maps, and Solutions to Computer Adventure Games* is divided into three main sections: Maps and associated Hint Sheets, Master List of Clues, and Complete Solutions. The following are instructions on how to use the information in each of these sections in the most productive manner.

A map of an adventure game is, in many ways, similar to an ordinary road map. Each rectangular box on the map represents a key location in the game (as would a city on a road map) and movement between boxes is typically achieved by typing in a directional command such as North, South, Northeast, and so on.* For these simple directional commands, the following notation is applicable. North and South are indicated by a *vertical* line between the bottom of the box corresponding to the present location and the top of the box corresponding to the location to which you are headed. Similarly, East and West are indicated by a *horizontal* line between the sides of the same boxes. If the game allows for diagonal directional commands such as Northeast, Southwest, again these directions are indicated by corresponding diagonal lines between appropriate corners of the two boxes in question.

In contrast to road maps, adventure game maps typically allow for movement between boxes with commands such as Up, Down, Climb the ladder, Enter the cage, and so on. To avoid confusion with these conventional directions, it is important to establish and maintain a consistent notation for these additional possibilities. In this book, Up and Down will be denoted by a *diagonal* line between the *top* of one box and the *bottom* of another. Specialized (non-directional) commands that cause transition from one box to another will be denoted by a *diagonal* line from the *side* of one box to the *side* of another.

Strange as it may seem, in some cases, the transition from one location (box) to another is on bi-directional; in other words, one might be required to go North to get from box A to box B but must go Southwest to get back to box A from box B. In such instances, an arrowhead pointing in the appropriate direction will be added to the directional line. When no arrowhead exists along a directional line, it is assumed that the transition corresponding to that line is bi-directional.

One other type of transition between map locations can occur in adventure

* Many adventure games accept abbreviations for these commands such as N for North, NE for Northwest, and so forth.

games. Quite often an indirect command such as saying a magic word or casting a magic spell will “teleport” the player from one location to another which may be far removed from his or her present position. To denote this type of movement, I have used a *dashed* line between the appropriate boxes.

Finally, it should be noted that, because of limitations on layout, it is sometimes necessary to break a directional line segment transitioning between two boxes. With regard to the directions that this line represents, whether or not it is broken is irrelevant. All that matters is its direction when it leaves or enters the box.

Since many of the adventure game maps are quite complex, it is helpful to identify the starting location on the map. To this end, I have used a box with a shaded perimeter to denote this starting location. If the game takes place in several parts, each being described by its own map-drawn page, then the shaded box notation has been applied to each such page.

Associated with every adventure map is a hint sheet that provides hints and clues for “breaking through” the key locations. The hints are provided in sequential order - in other words, an order in which they would be needed to successfully play through the game from beginning to end. It is to be emphasized that this ordering is not unique; that is to say, in some instances it is possible to traverse through the key locations in a different order and still win the game. In many cases, however, the solution to the puzzle that allows the player to break through a particular key location can only be accomplished after having broken through certain other key locations. The simplest example of this might be the necessity to find a key (in one key location) that allows opening a door (in another key location). In such cases, the order of events is important and cannot be reversed.

Each clue on the hint sheet (identified by its location number) has a corresponding circled number located on one of the boxes of the map. Since, in general, a given location in the game will be traversed more than one time during play, many of the key locations may have several hints (circled numbers) associated with it. As such, it should not be surprising to find that the starting location (the box with the shaded perimeter) may wind up to be a key location with a clue number other than 1. In that case, the puzzle that must be solved in this location only becomes significant after having played a portion of the game.

The actual clues themselves are also identified by numbers (clue numbers) and

their content is obtained by associating these numbers with a scrambled Master List of Clues for all of the games. Each clue number is used once and only once (never repeated in any other game) and as such corresponds to a unique clue in this Master List. Also, when a player looks up a particular clue corresponding to a certain key location in the game currently being played, he or she will obtain only the specific information being sought since the adjacent clues in the Master List will be for totally different games. The use of such an unencumbered yet effective scrambling scheme is essential to preserving the challenge.

A simple example serves to illustrate all of the above points. Suppose that, for the fictitious game, *The Moldavian Conquest*, the first five clues of the hint sheet appear as follows:

<u>Location Number</u>	<u>Clue Number</u>
1	49
2	358
3	92
4	110
5	2

To use this information, one would begin the game at the starting location (the box with the shaded perimeter) on the corresponding map and play along until he or she reached the key location (box) with a circled number 1. At this point, if a hint were needed to continue the game, the player would look up clue number 49 in the Master List. Assuming that the player correctly interpreted and used the clues found there, he or she would proceed with the play of the game until reaching the box with a circled number 2. Thereupon, if help was needed, the player would look up clue number 358 in the Master List and after making successful use of the information found there, would proceed on to key location #3, and so on.

If, after using the complete hint sheet, the player is still unable to solve the adventure, *Hints, Maps, and Solutions to Computer Adventure Games* contains an added bonus not found in other books of this type. The third and final section of the book is a series of complete step-by-step solutions (walk-throughs) for those games where it is possible to define unique solutions and which, in the authors opinion, are sufficiently

complex to warrant including the section. Starting with these solutions rather than the combination of the map and hint sheet is like giving up on a puzzle before you open the box and remove the pieces. **Thus, I strongly urge the player to use these solutions only after he or she has lost as much sleep as I have in arriving at them.** In writing these solutions, I have incorporated many parenthetical expressions which represent the responses provided by the game to the player's commands. These expressions are included merely to add to the enjoyment of playing the game and are not to be typed in as part of any command.

Before closing, I would like to point out to the user of this book that every effort has been made to assure the accuracy of the information contained within. To this end, I have personally played every game through to completion twice on an Apple IIe computer or an Apple Macintosh SE, each time using the map and the step-by-step solution and/or the hint sheet as guides. Thus, in theory, the user should expect a perfect manuscript.

However, due to the complex nature and potential randomness of some of the games coupled with the chance of slight variations between versions for different computers*, there exists the possibility of imperfections. Because of these uncontrollable factors, neither the author nor the publisher can assume responsibility for the fallibility of the maps, hint sheets, or complete solutions.

* Every adventure game manufacturer that I contacted indicated that no such variations existed.

Tips on Playing Adventure Games

Unlike most other types of software on the market, the typical computer adventure game consists of little else than a disk (or disks) in a box. Although some adventure game manufacturers are now trying to glorify the package by including such items as comic books, newspapers, color wheels, and similar items which contain key clues for solving the game, the essence of the matter is that the adventurer is basically left on his or her own to figure out the mysteries of: 1) How do I start the game? 2) What strategies shall I employ along the way? and 3) What is the ultimate purpose of my mission?

The brief discussion that follows is an attempt at answering these perplexing questions in the general context of the adventure games that are included in this and other books of this type.

A common thread among all adventure games is the necessity of accumulating an inventory of items that you, the adventurer, find along the way. These items (some of which may wind up to be of no value) are used to solve the various puzzles that occur throughout the game. Thus, the first thing to do when starting an adventure game is to determine what items you have in your inventory at the outset. This is typically done by typing the command: INVENTORY (most games accept an abbreviation of this word like "I" or "INV").

Next, you must begin to explore your surroundings. Before leaving your present location, however, LOOK at or EXAMINE every object in the "room." In fact, this is something you should do every time you move to a new location. When you are convinced that you have seen all there is to see and taken all that there is to take, you are ready to move on. Just type in a directional command such as North, West, and so on (again, abbreviations such as "N" and "W" are accepted by most games) and you will move to the next game location in the chosen direction.

The best way to keep track of your movements is with the use of a map such as those contained in the first section of this book. When first playing a game, it is wise to map as much of it as you can without paying strict attention to what is happening in each room. This gives you a feel for the geography of the game before you set out to solve the intricacies of its various puzzles.

Most games only allow for a limited inventory so you can only carry a certain number of possessions with you at any given time. Thus, you must judiciously DROP items from time to time when you think you either don't need them at the present time or have already made full use of them and won't need them again. In certain games, you may find a receptacle such as a sack or a pouch to carry items in. Putting your inventory items in this receptacle often allows you to carry more than if you carried these same items individually.

Quite often the player will encounter a maze within the adventure game itself that must be negotiated before play can continue. Here again a map is quite helpful. Since typically in a maze, the descriptions of the locations are identical, the construction of such a map is a bit more challenging. Here is another use for the inventory items you have collected thus far. As you move through the maze DROP an item every few maze locations. These then serve as markers to help you distinguish one location from another and help you find your way back in the same manner that Hansel and Gretel used their bread crumbs to retrace their steps.

Another pointer is to pay careful attention to the description of your inventory items when you LOOK at them after you have TAKEN them. These descriptions often contain clues as to how these items should be used. Don't always expect an item to be used in its most common application. For example, a lock is most often opened with a key; but perhaps a toothpick might accomplish the same as picking the lock.

Always make full use of the vocabulary allowed by the game. For example, SEARCHING an object often reveals more than merely LOOKING at it. CAREFULLY EXAMINING it might reveal even more.

Finally, don't try to accomplish too much in one sitting. Even the most experienced of adventurers will require many sessions to solve a game. In this regard, SAVE your game often and in as many locations as the game allows SAVE positions. In this way, you can try many different strategies to get through the tough spots without having to start from scratch each time.

Happy adventuring!!

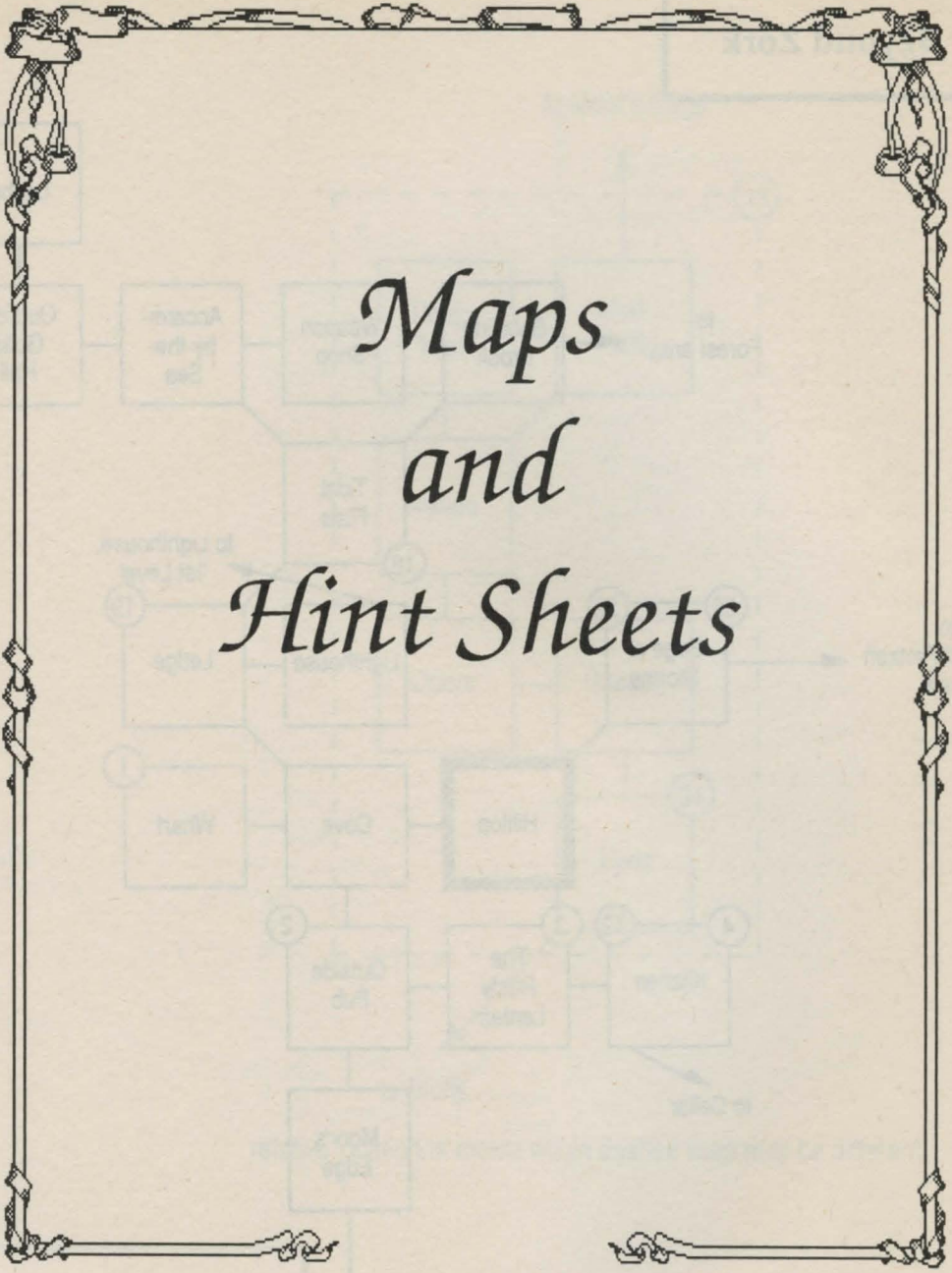
A decorative border with ornate, symmetrical corner pieces and repeating motifs along the sides, enclosing the central text.

*Maps
and
Hint Sheets*

Beyond Zork

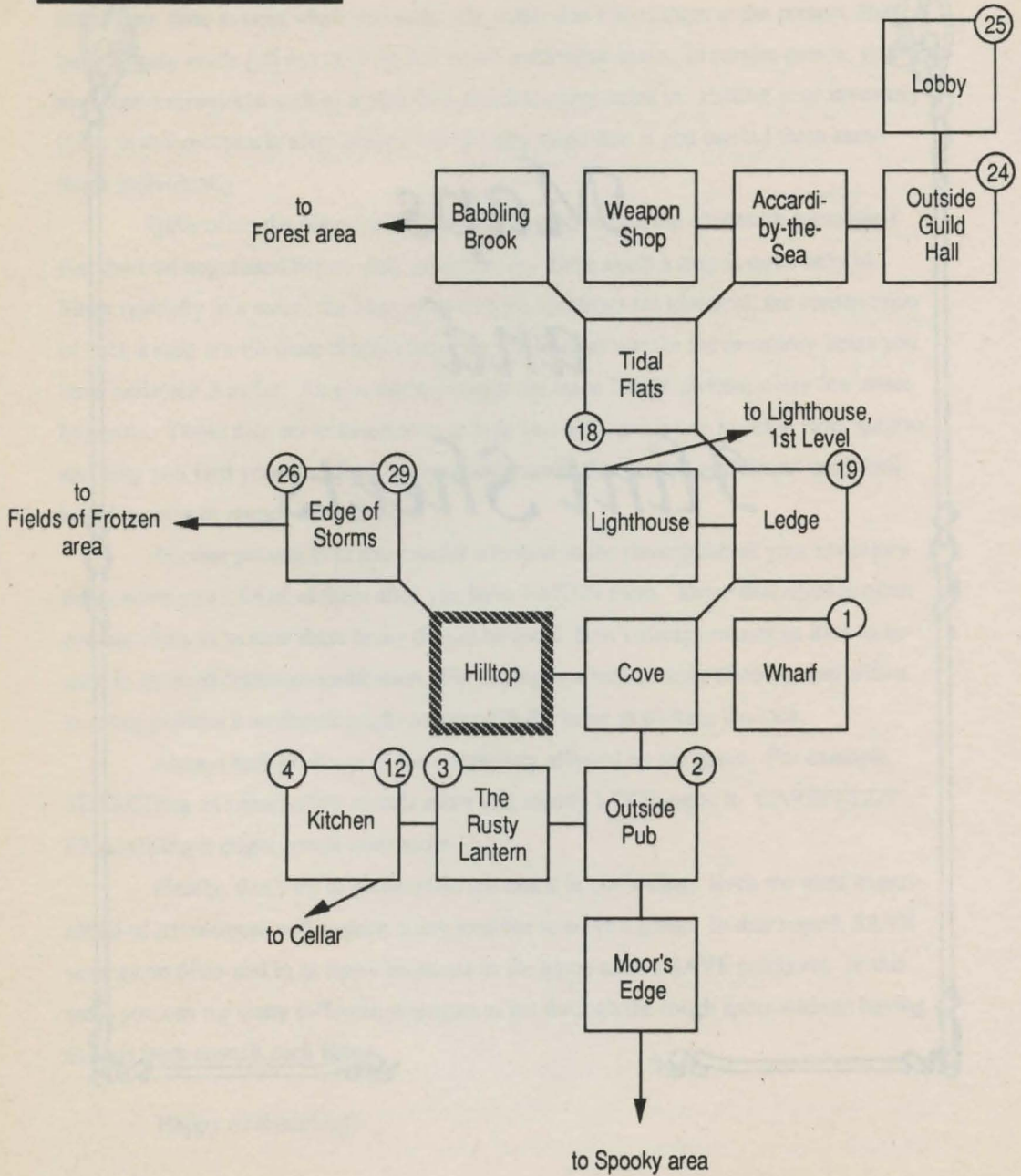

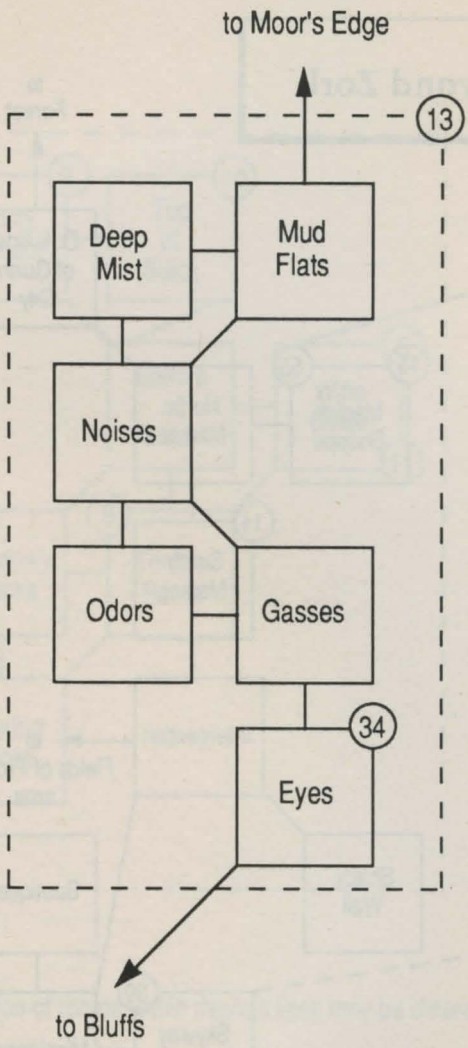

relative location of rooms within dashed lines may be different

Beyond Zork

Beyond Zork

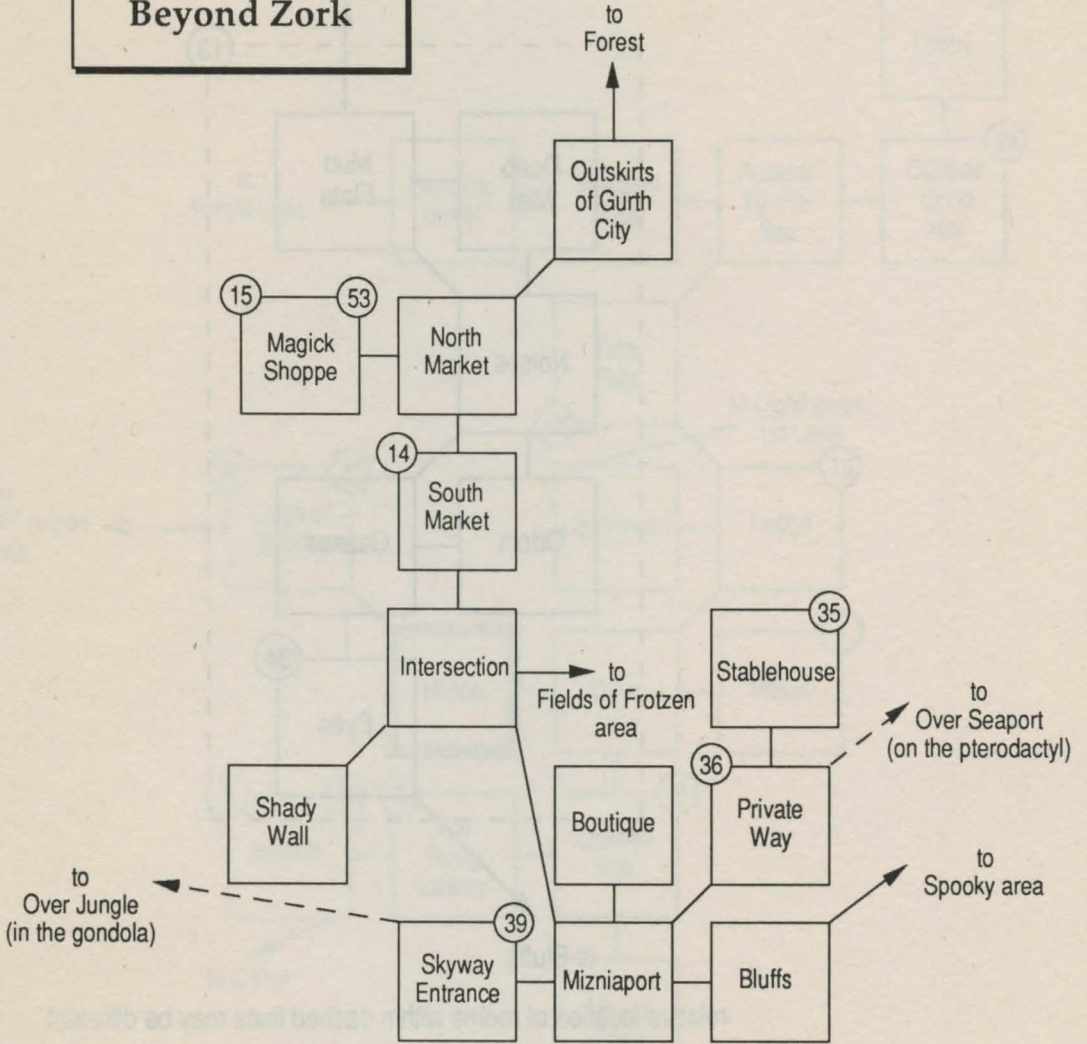

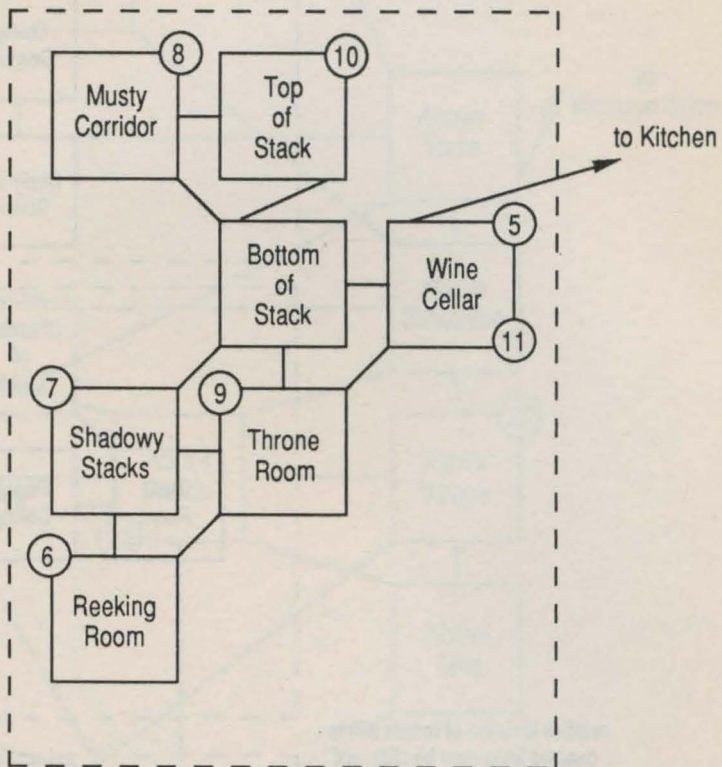

relative location of rooms within dashed lines may be different

Beyond Zork

Beyond Zork

relative location of rooms within dashed lines may be different

Plane of Trans-Infinite Splendor

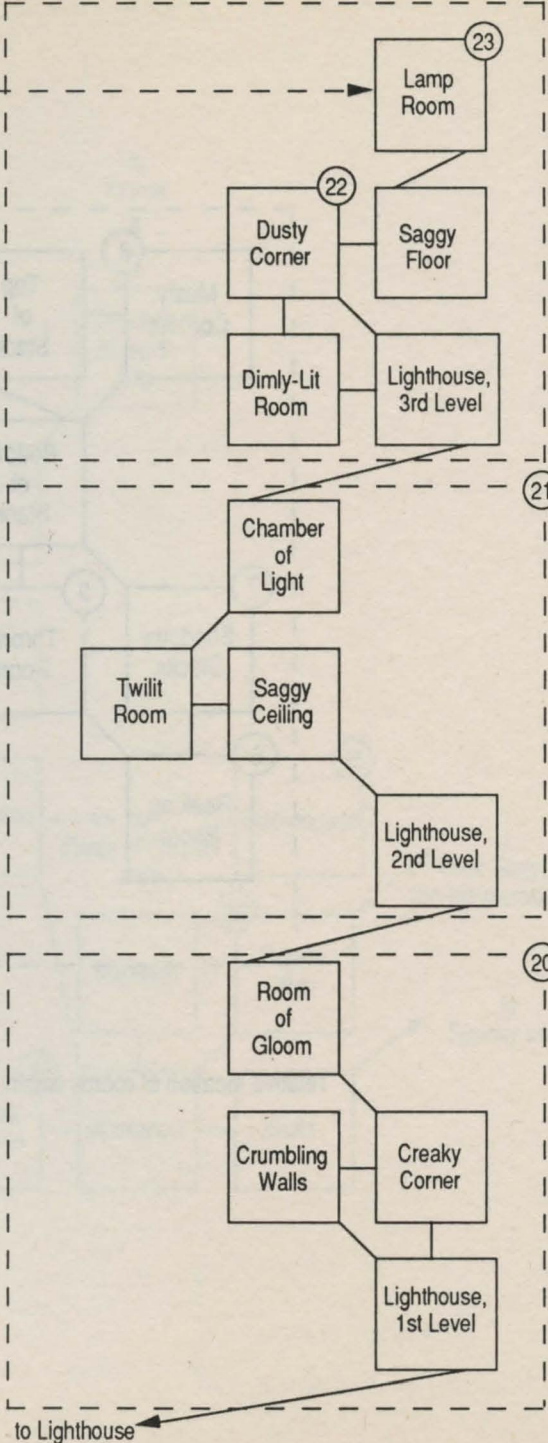

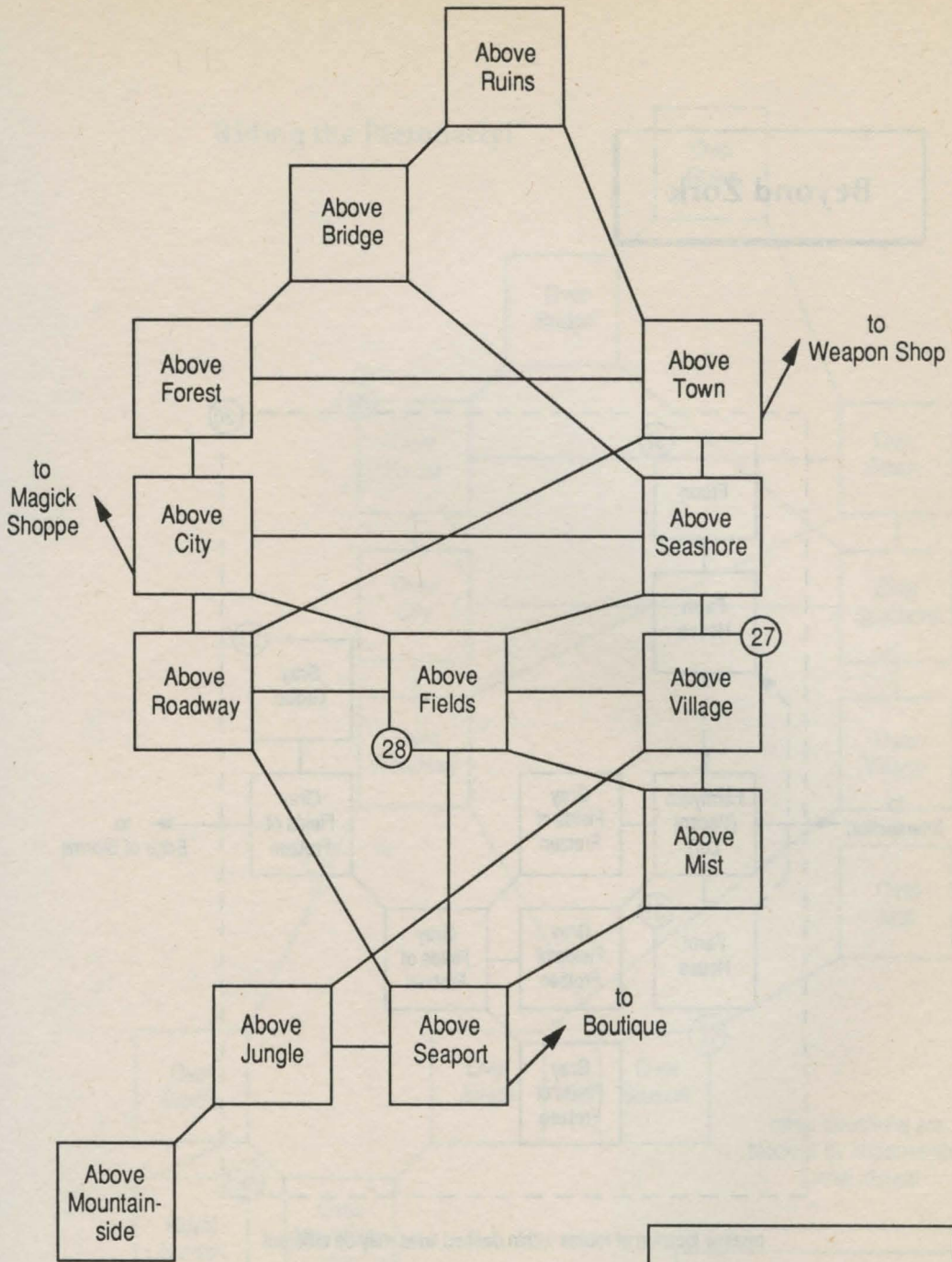

Beyond Zork

Beyond Zork

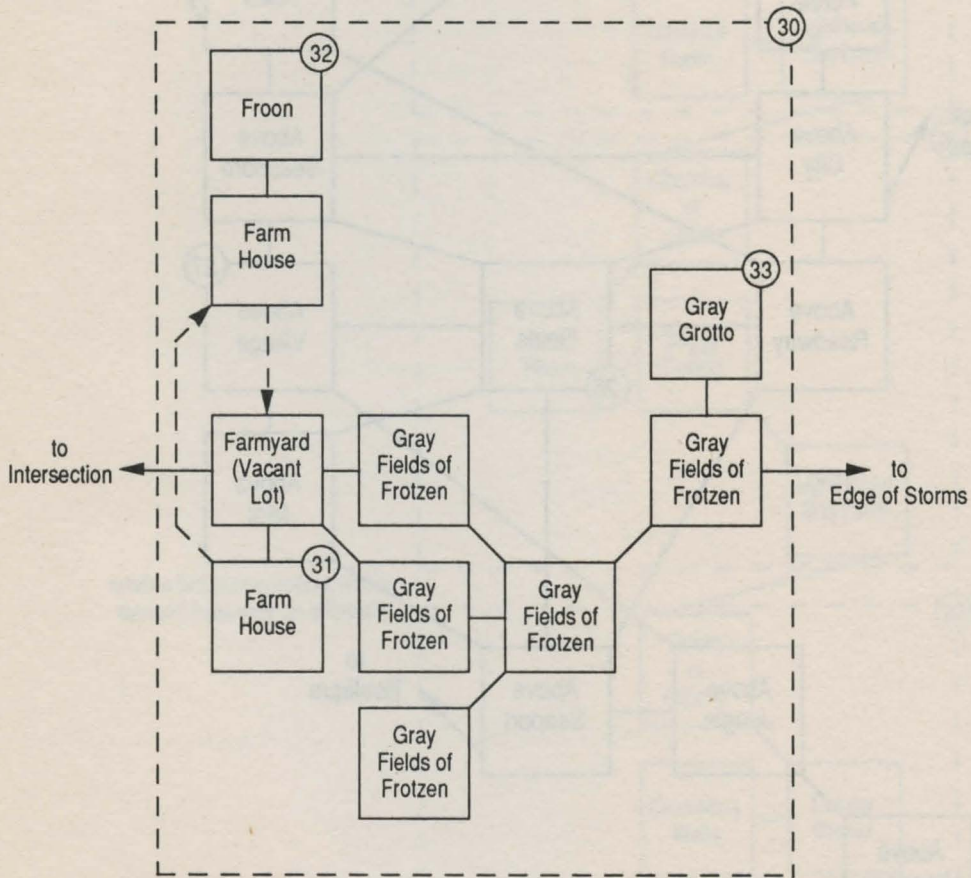

relative location of rooms within dashed lines may be different

Riding the Pterodactyl

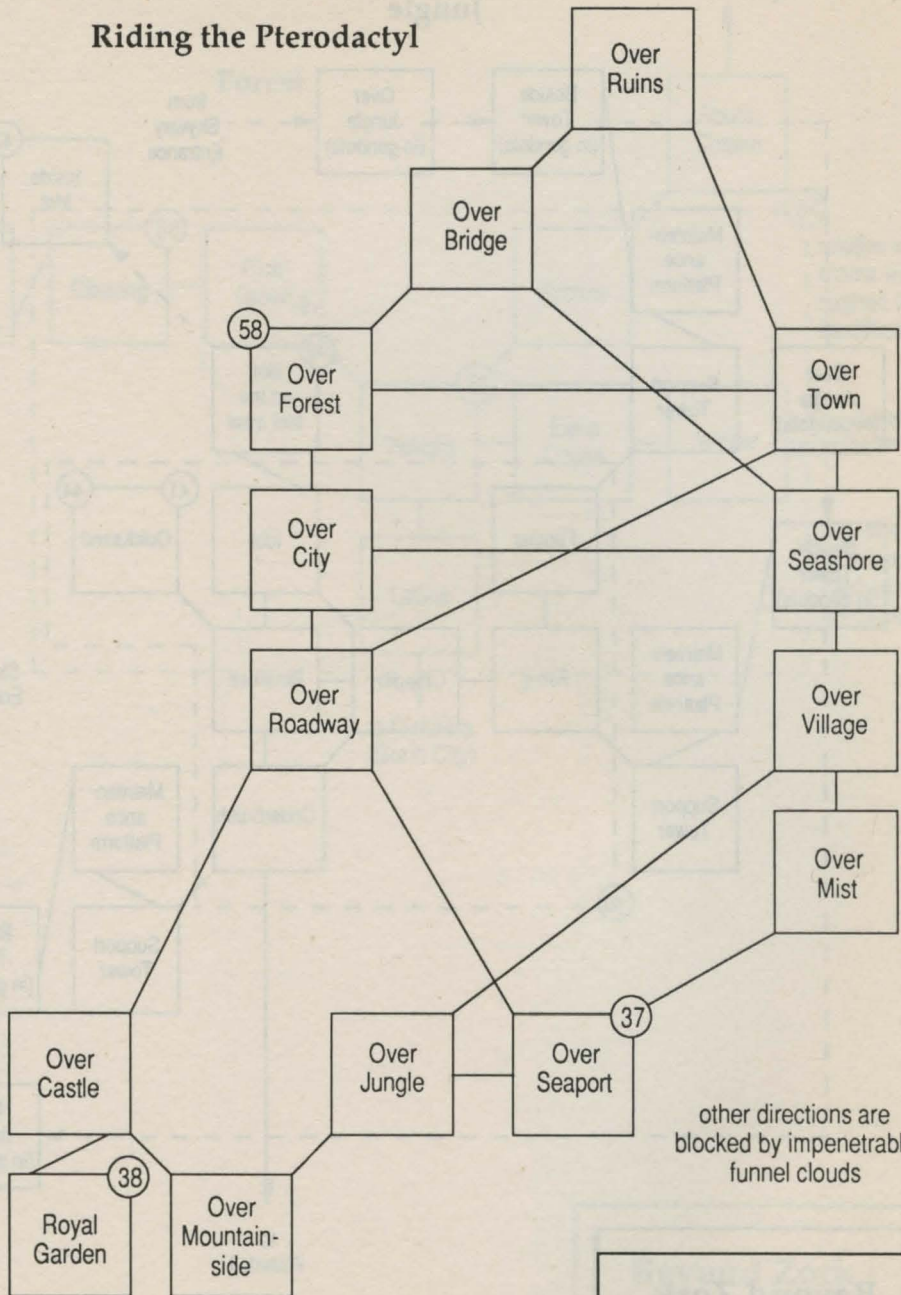

Beyond Zork

Jungle

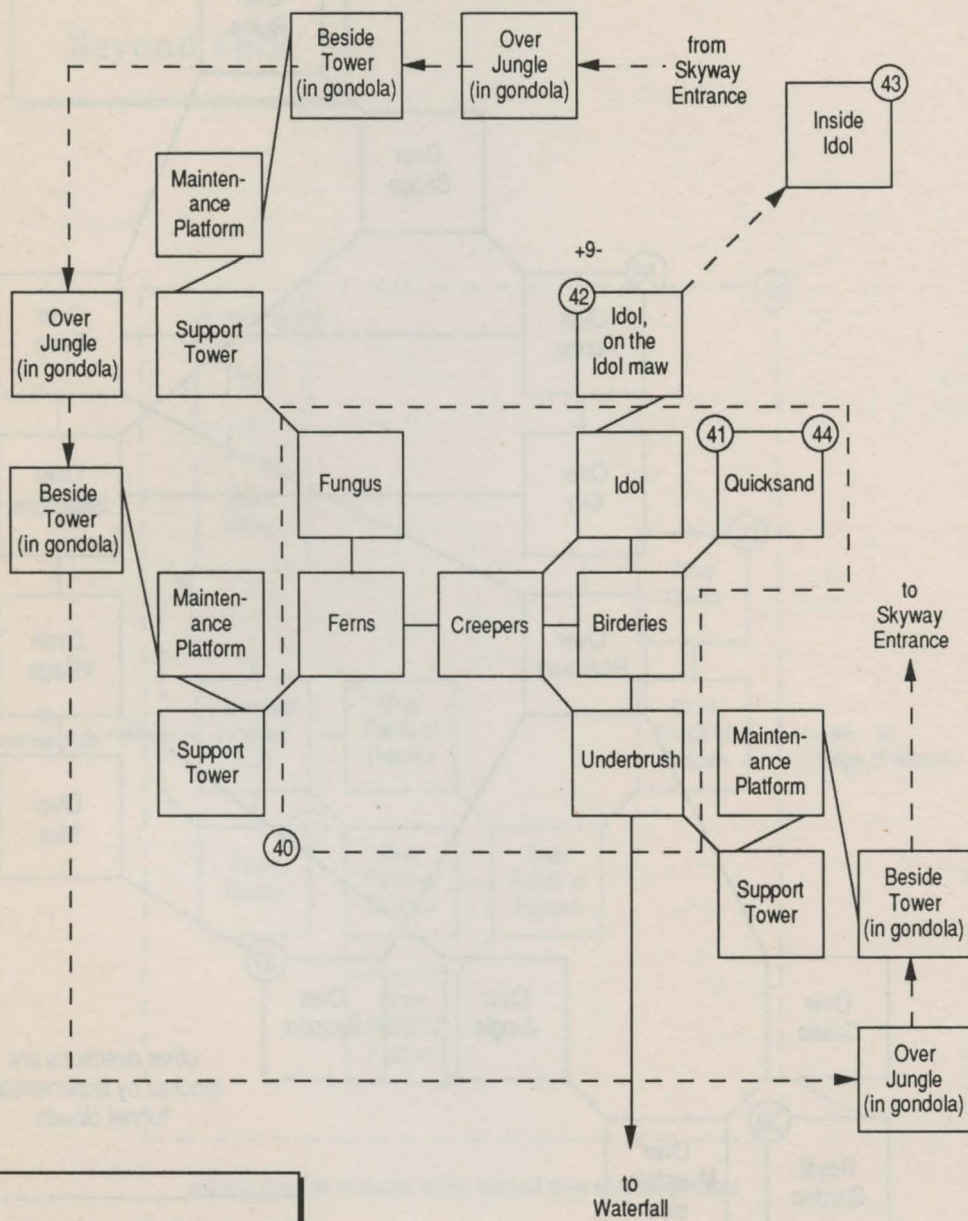

Beyond Zork

relative location of rooms within dashed lines may be different

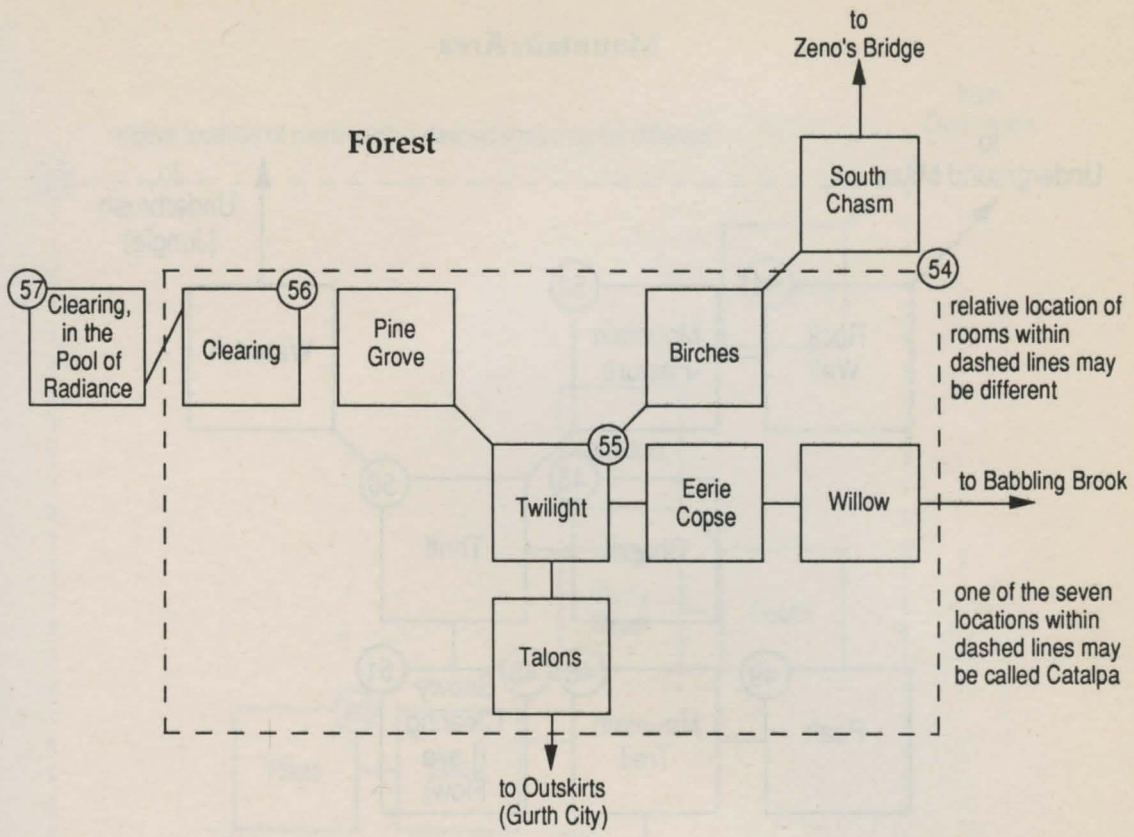

Beyond Zork

Mountain Area

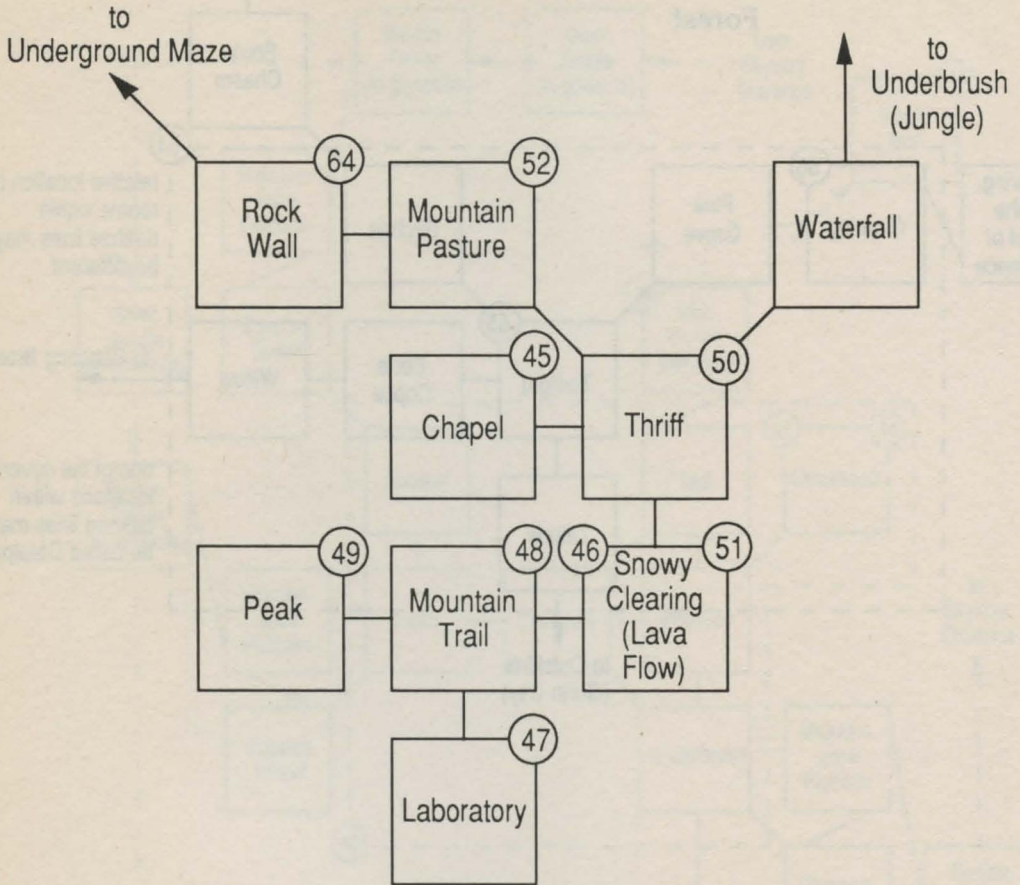

Beyond Zork

Ruins

relative location of rooms within dashed lines may be different

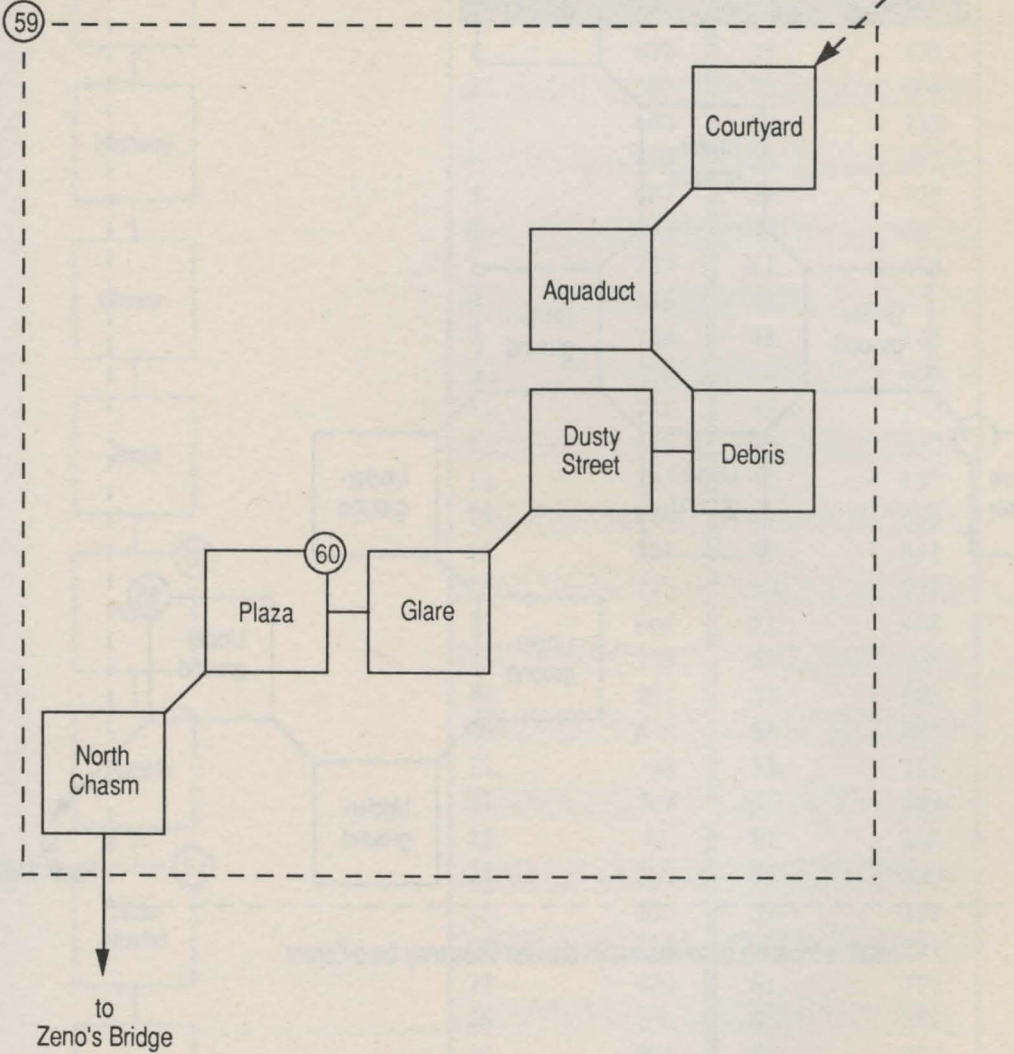

Beyond Zork

Underground Maze

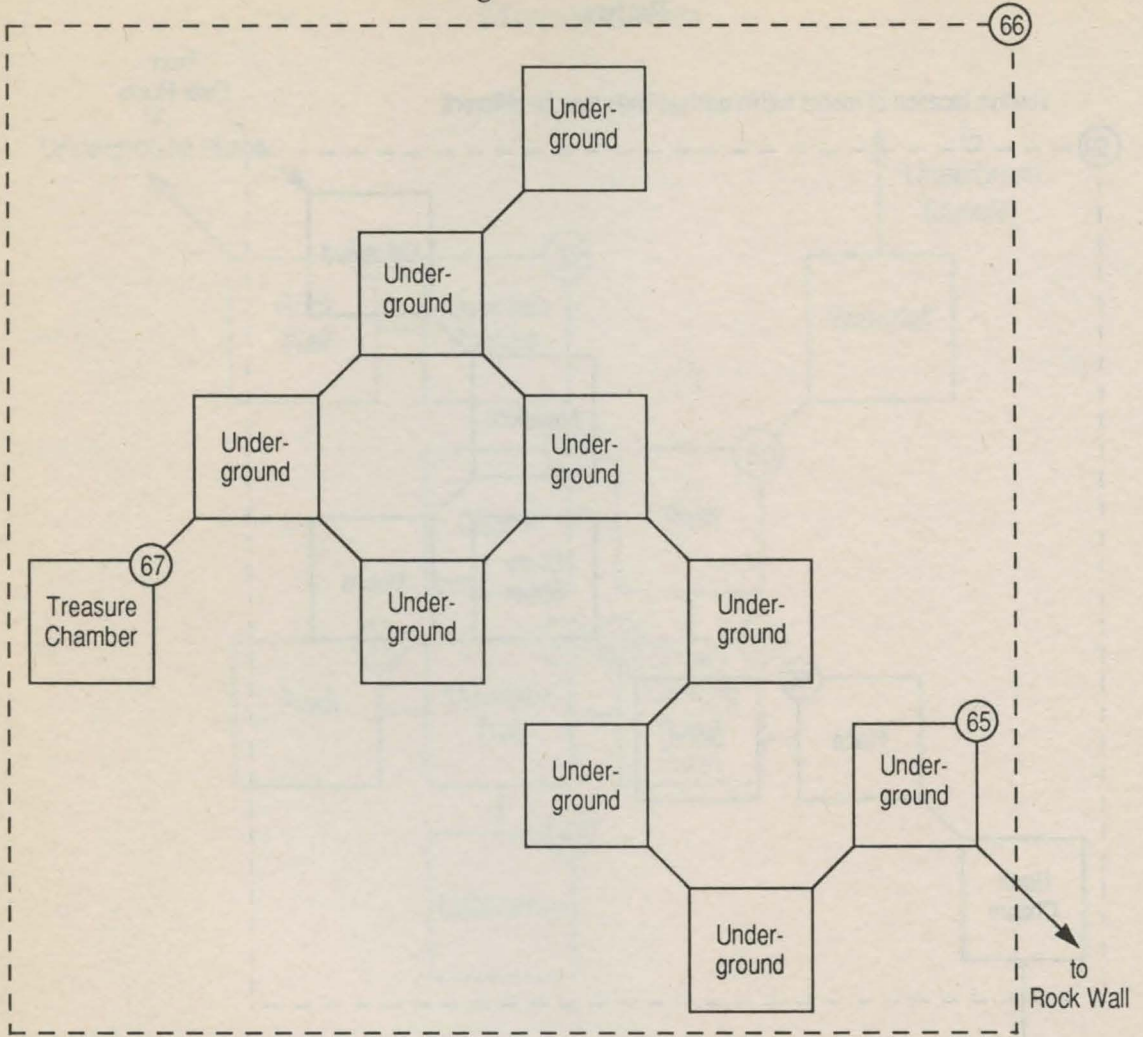

relative location of rooms within dashed lines may be different

Beyond Zork

Under the Arch

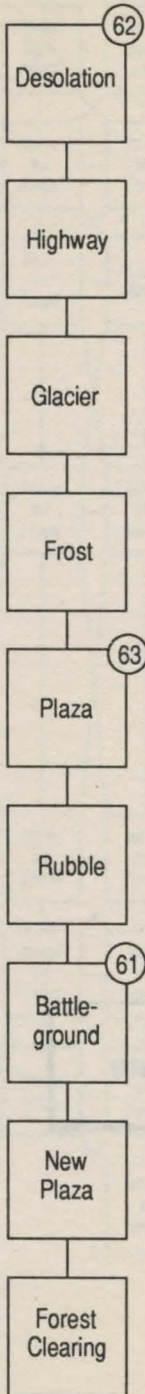

Beyond Zork			
1.	872	35.	129
2.	560	36.	604
3.	662	37.	732
4.	410	38.	291
5.	607	39.	426
6.	843	40.	33
7.	237	41.	468
8.	596	42.	17
9.	754	43.	166
10.	652	44.	603
11.	711	45.	792
12.	280	46.	532
13.	883	47.	457
14.	680	48.	490
15.	321	49.	841
16.	713	50.	797
17.	644	51.	448
18.	108	52.	39
19.	201	53.	585
20.	636	54.	803
21.	548	55.	133
22.	767	56.	819
23.	41	57.	204
24.	869	58.	890
25.	220	59.	179
26.	615	60.	221
27.	420	61.	771
28.	98	62.	542
29.	901	63.	425
30.	773	64.	402
31.	383	65.	389
32.	314	66.	726
33.	219	67.	817
34.	731		

The Train

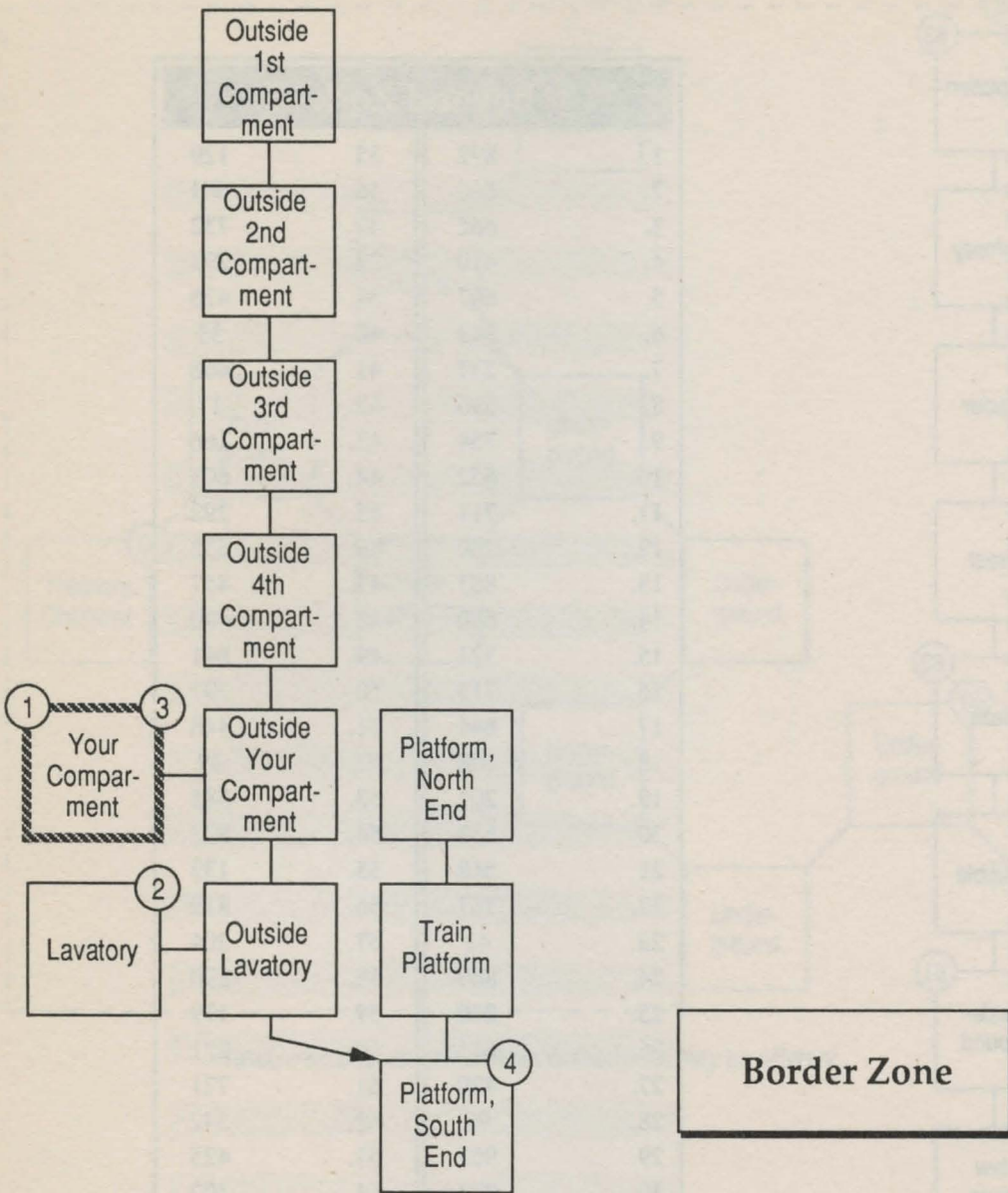

The Border

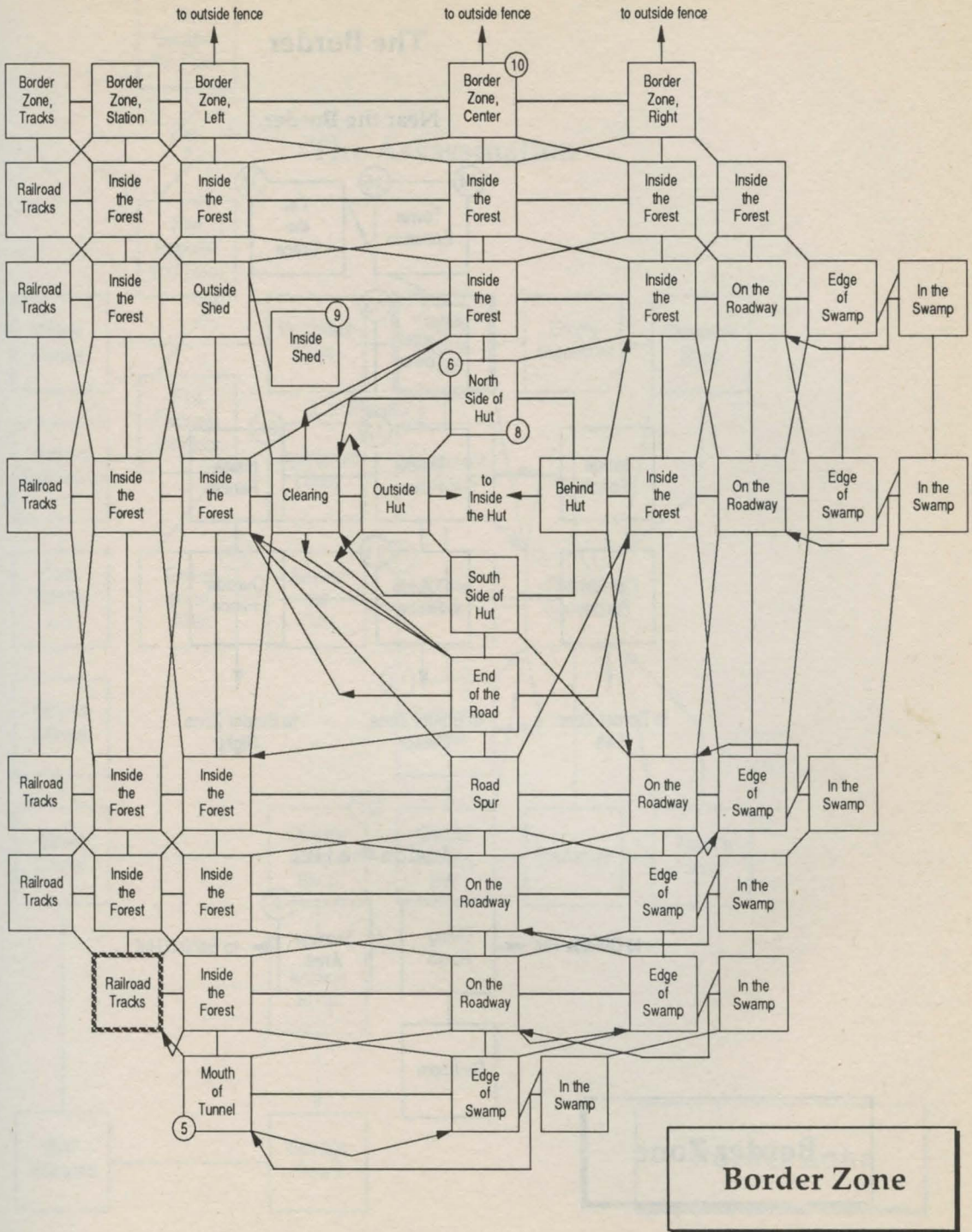

The Border

Near the Border

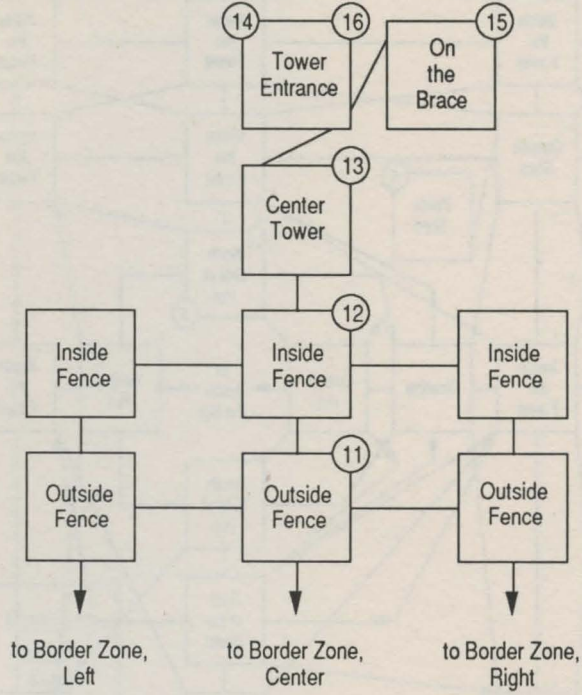

Inside the Hut

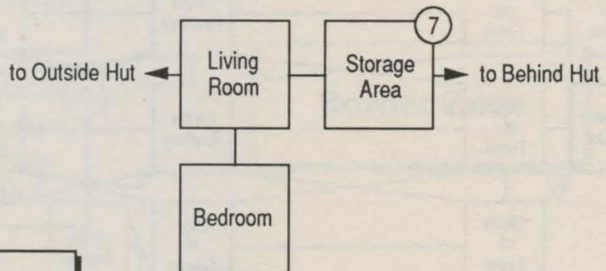

Border Zone

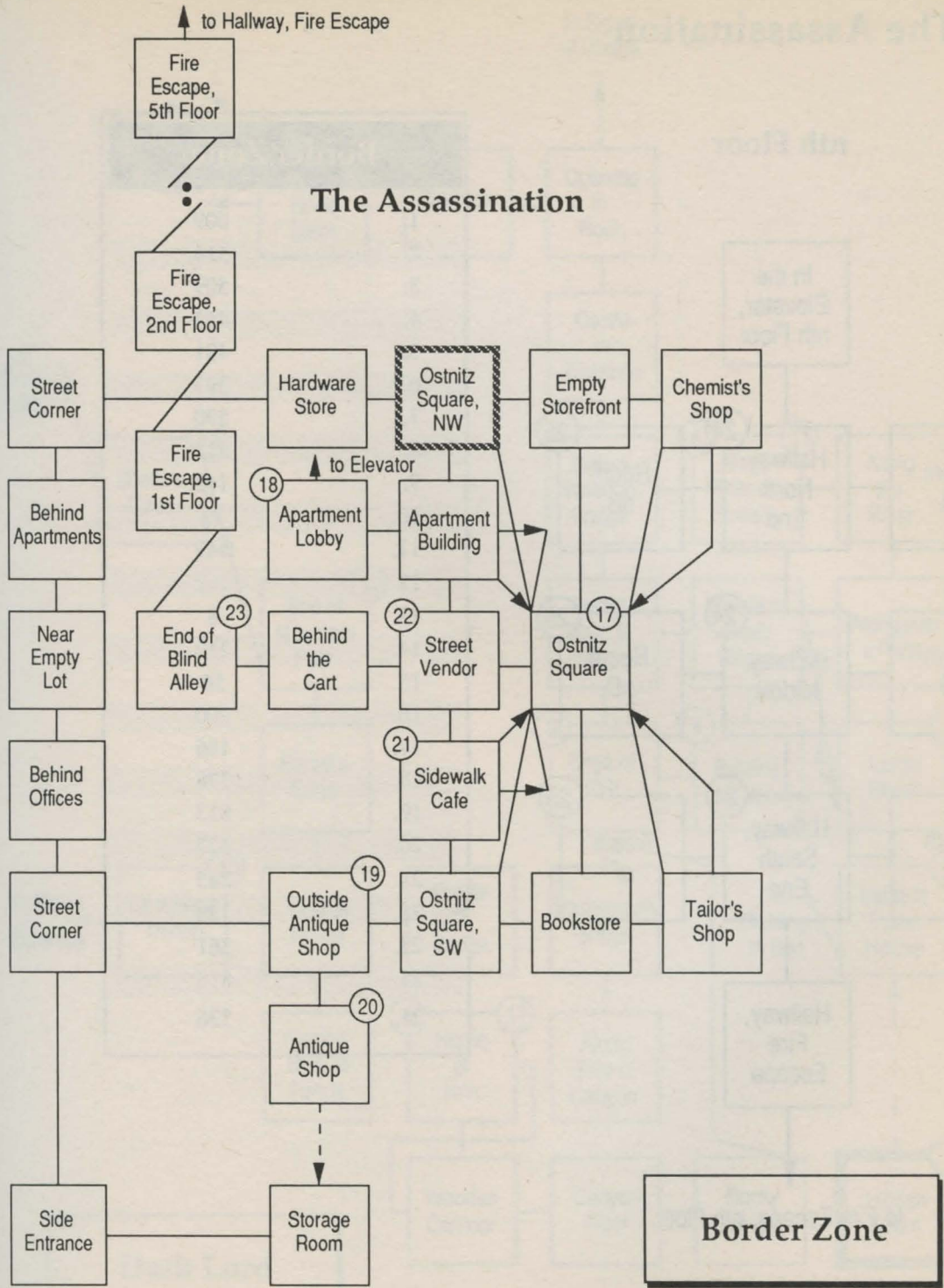

The Assassination

nth Floor

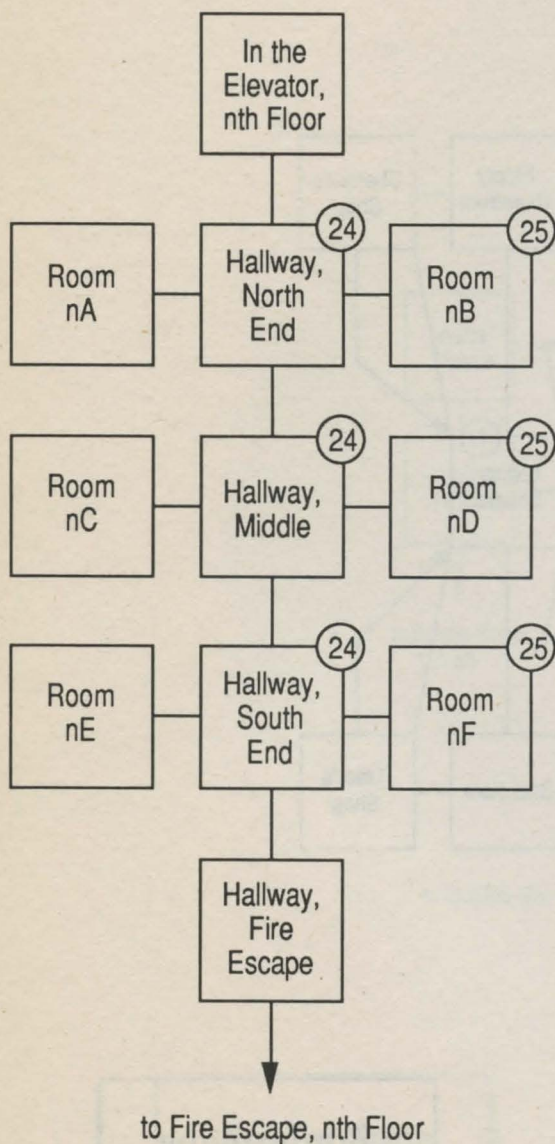

Border Zone

1.	609
2.	514
3.	509
4.	453
5.	481
6.	393
7.	590
8.	613
9.	142
10.	72
11.	549
12.	162
13.	8
14.	212
15.	56
16.	200
17.	186
18.	378
19.	813
20.	327
21.	795
22.	128
23.	361
24.	815
25.	336

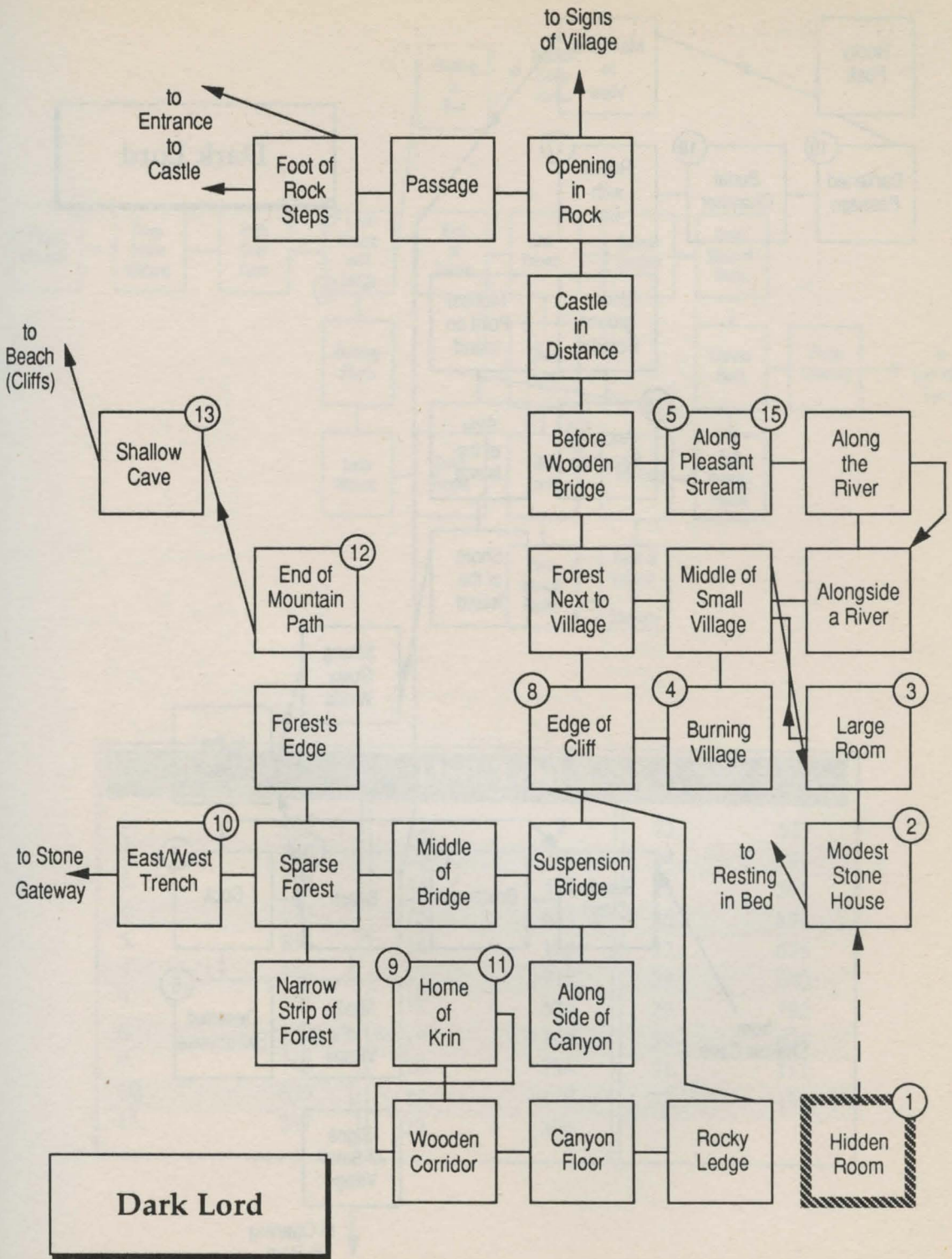

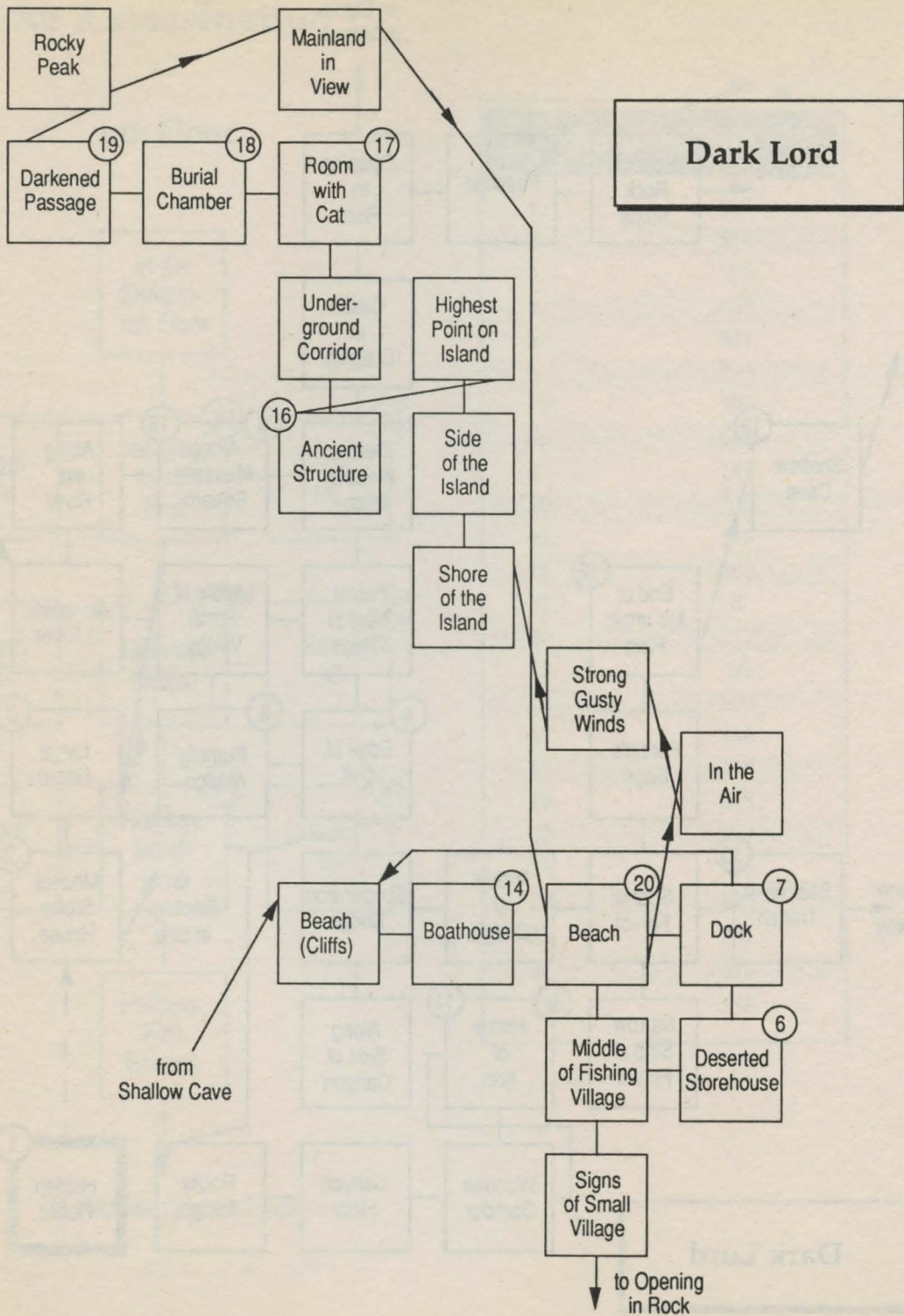

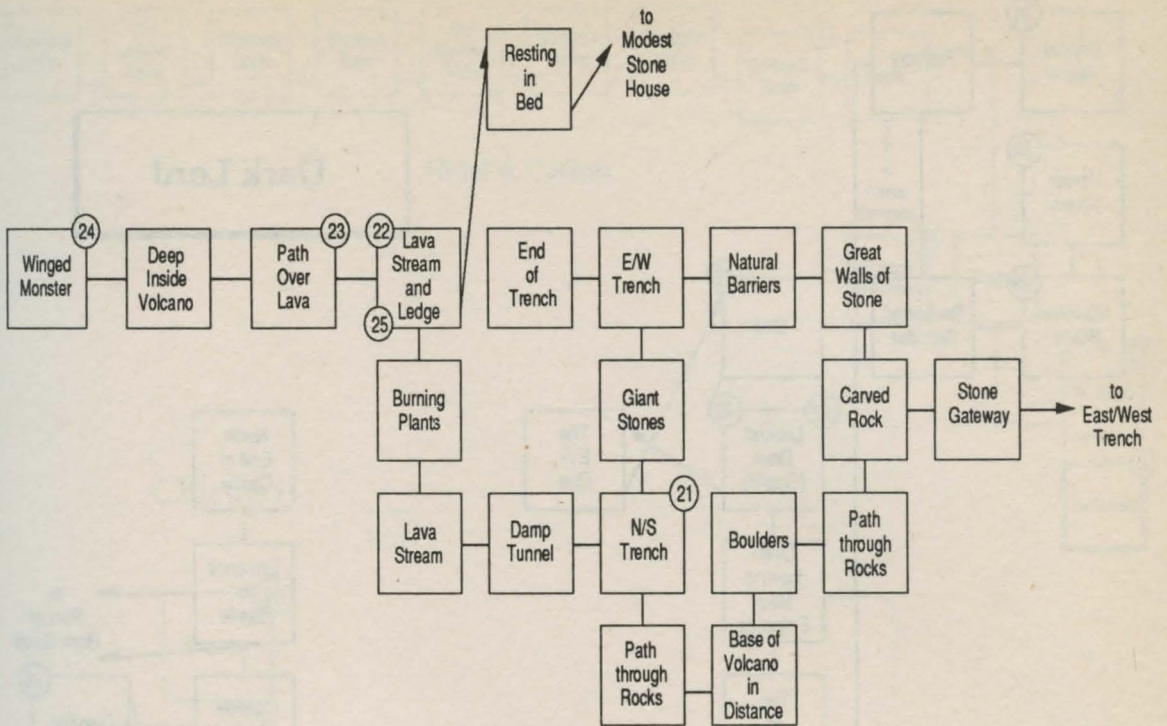

Dark Lord					
1.	135	12.	2	23.	527
2.	865	13.	333	24.	791
3.	525	14.	187	25.	391
4.	673	15.	651	26.	874
5.	856	16.	183	27.	675
6.	846	17.	718	28.	290
7.	501	18.	534	29.	192
8.	153	19.	164	30.	606
9.	768	20.	794	31.	112
10.	630	21.	117	32.	138
11.	307	22.	309		

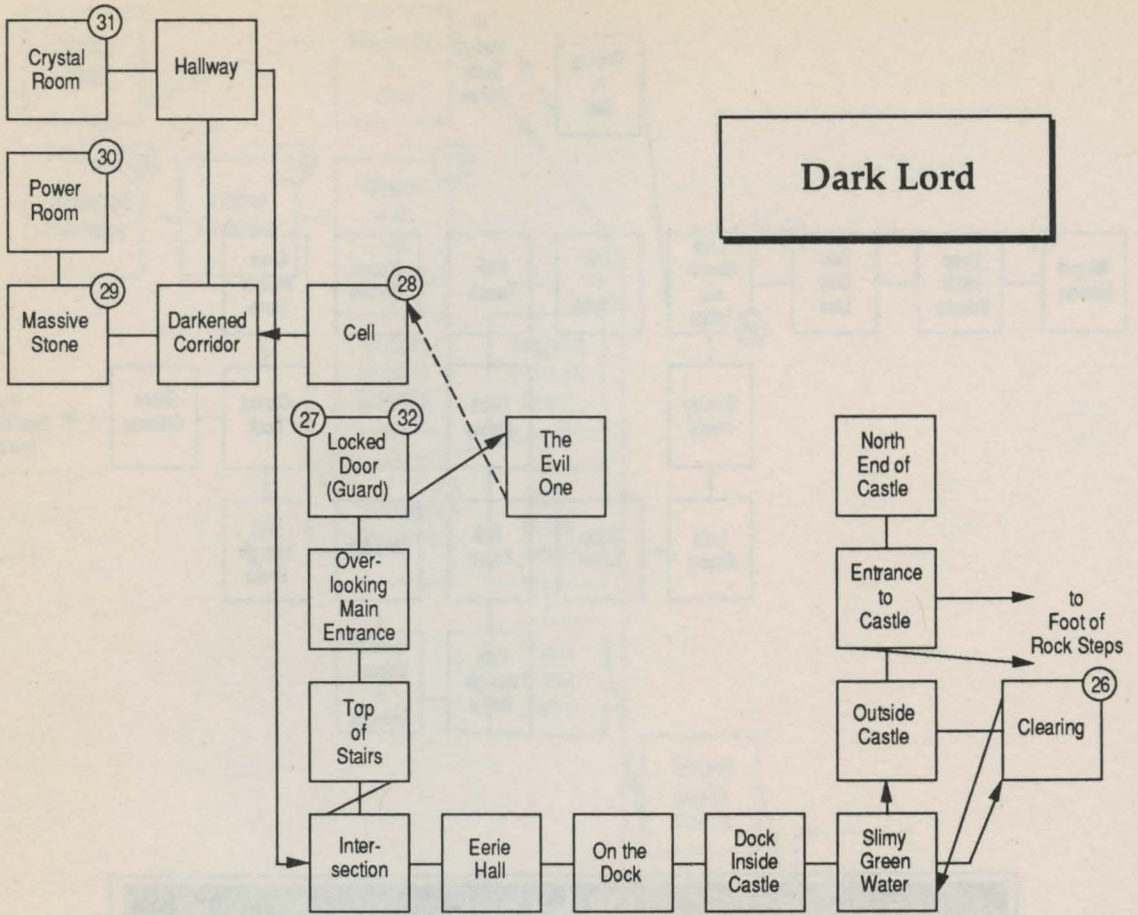

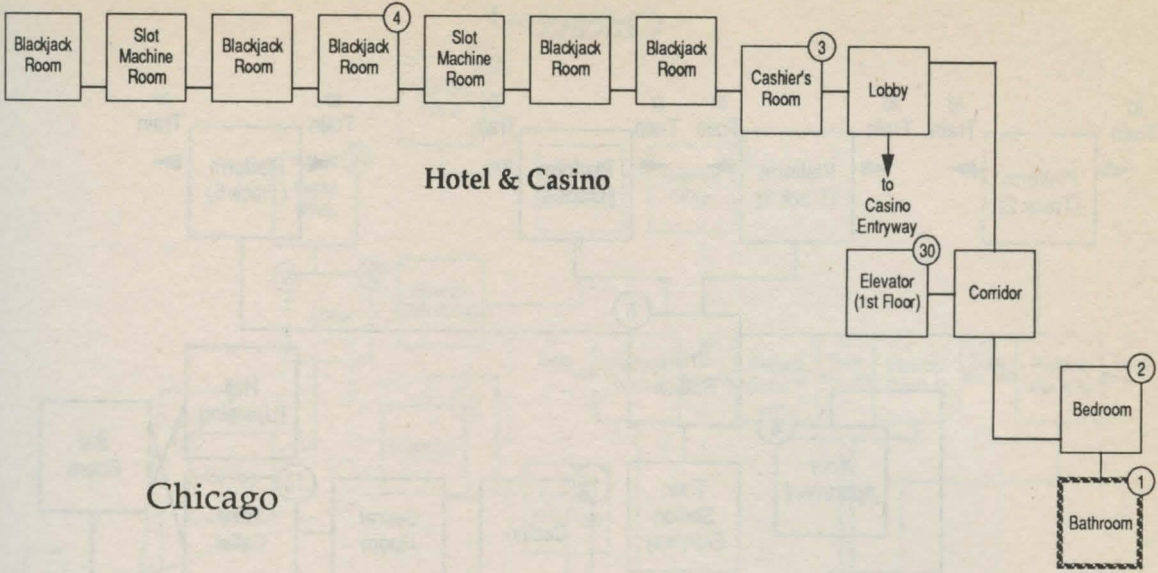

Chicago

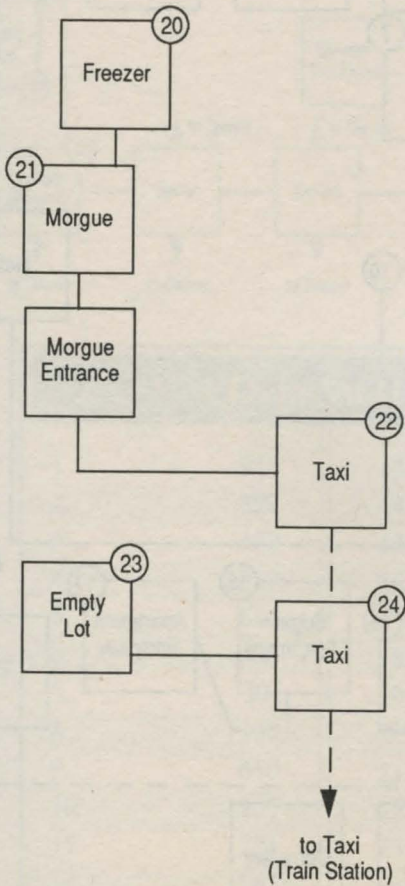

**Deja Vu II:
Lost in Las Vegas**

Chicago

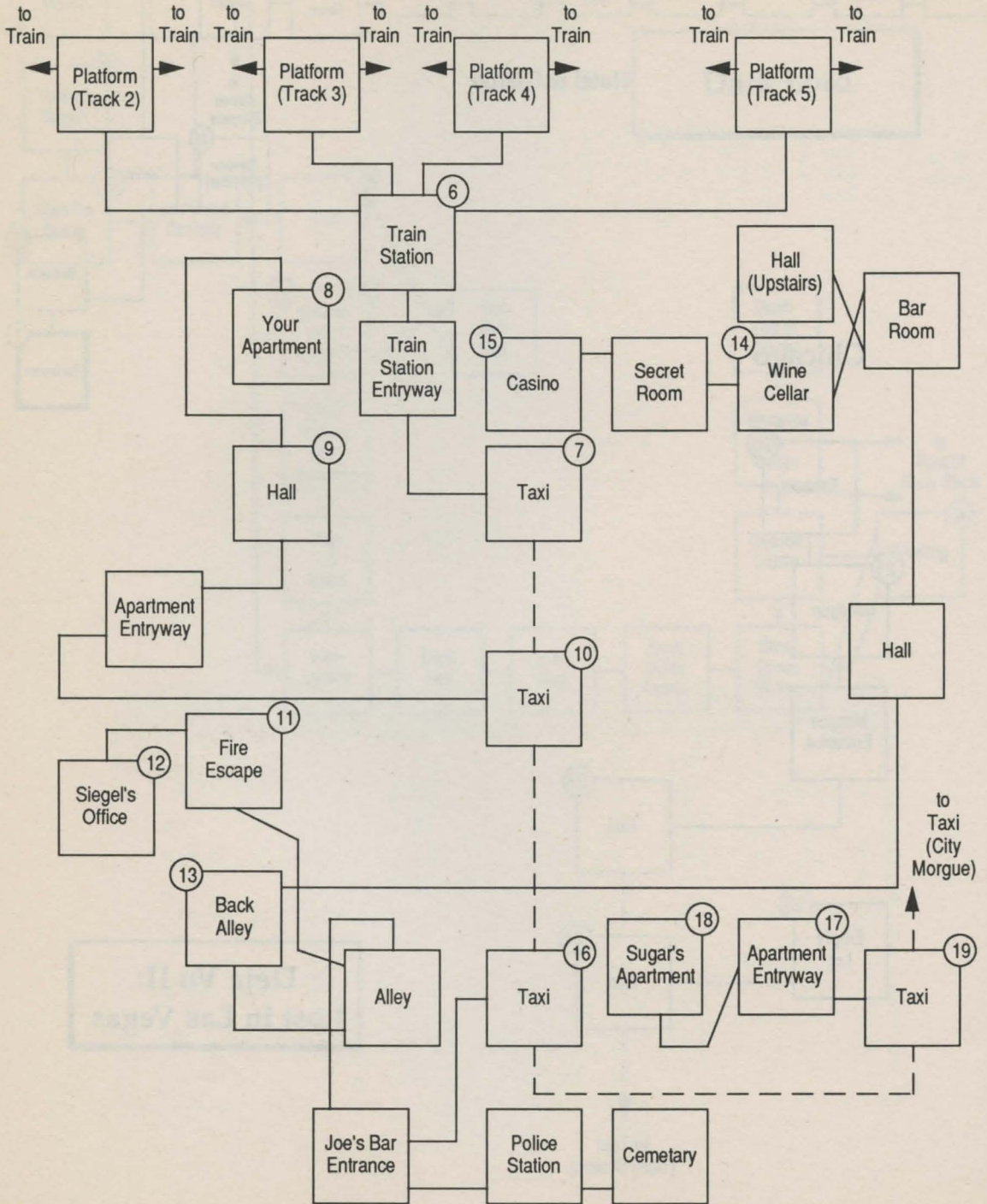

Las Vegas

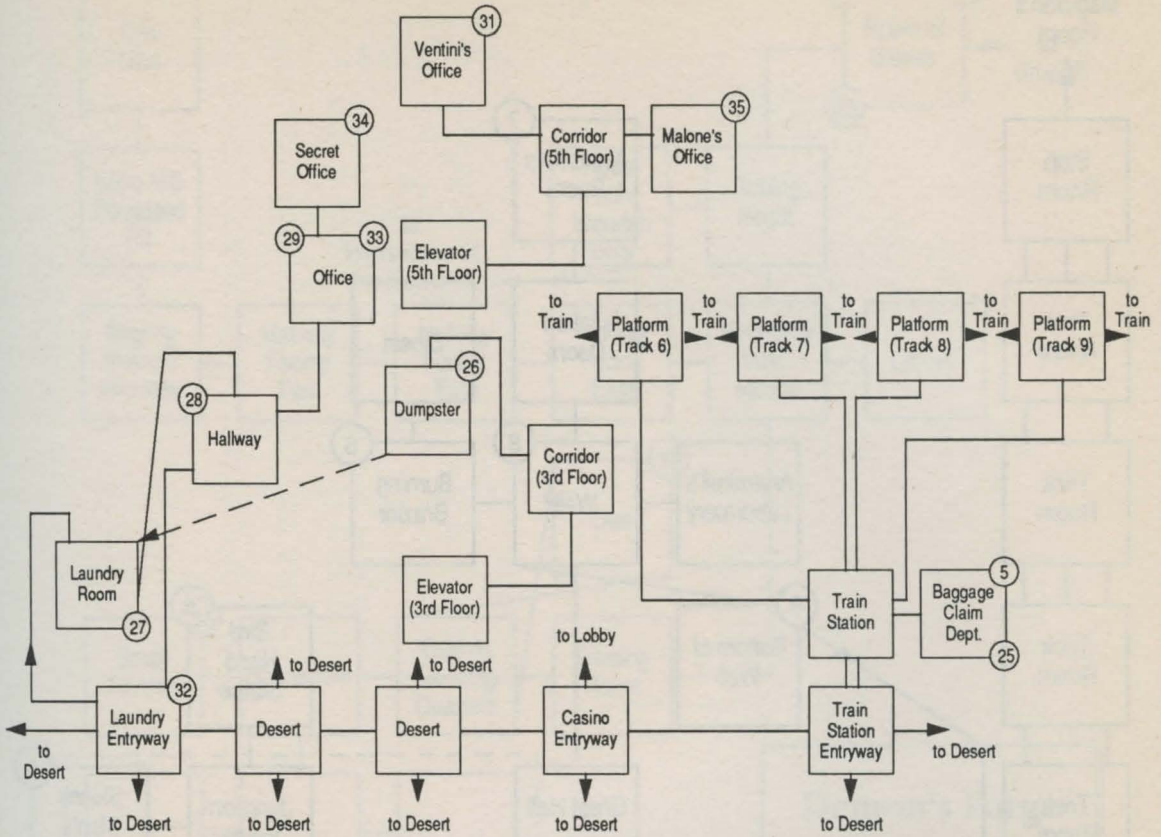

Deja Vu II: Lost in Las Vegas

1.	915	13.	895	25.	444
2.	392	14.	502	26.	19
3.	470	15.	59	27.	709
4.	879	16.	571	28.	447
5.	645	17.	642	29.	733
6.	430	18.	102	30.	371
7.	81	19.	25	31.	697
8.	158	20.	922	32.	690
9.	610	21.	370	33.	29
10.	203	22.	82	34.	884
11.	274	23.	622	35.	858
12.	265	24.	825		

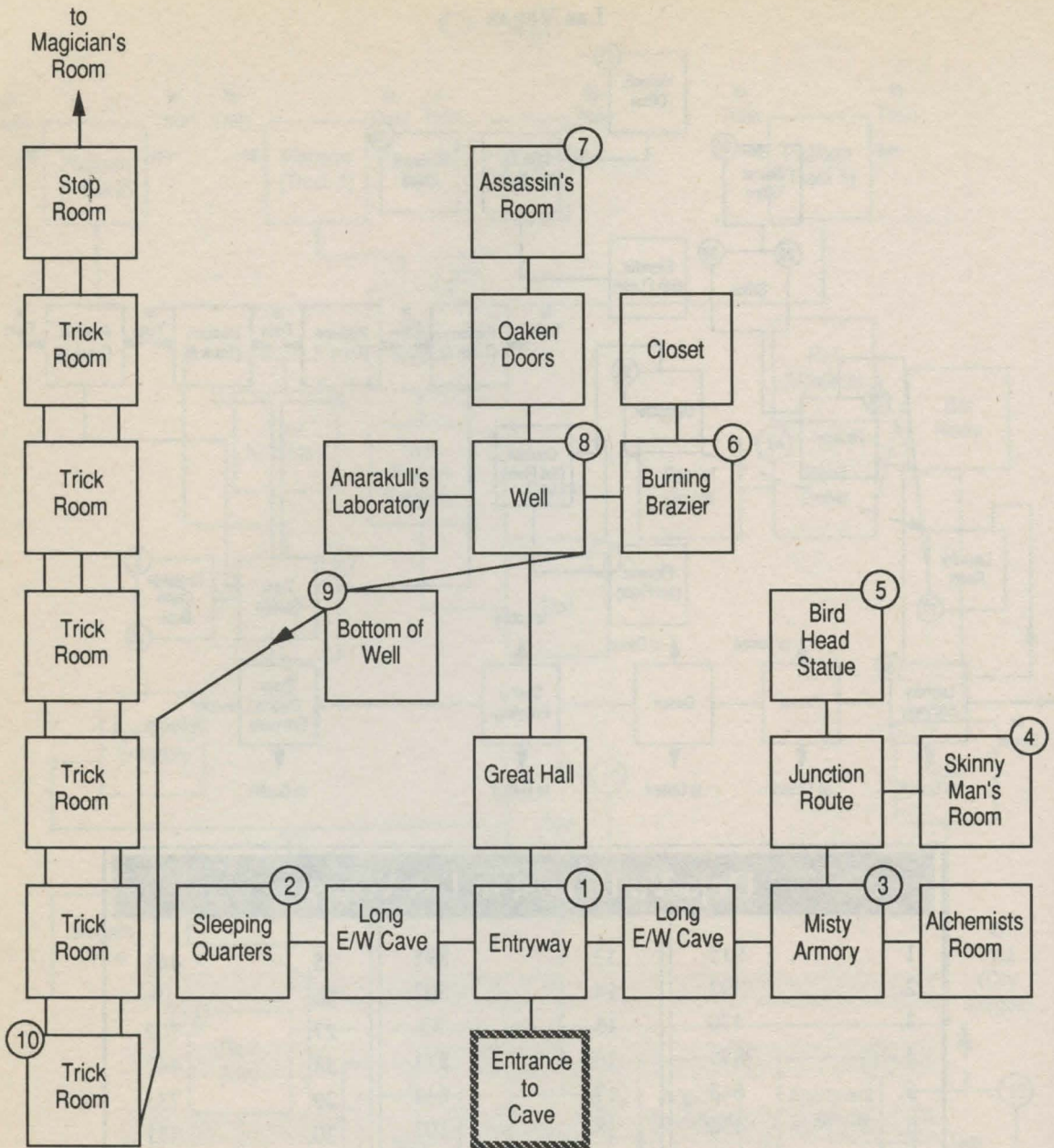

Demon's Forge

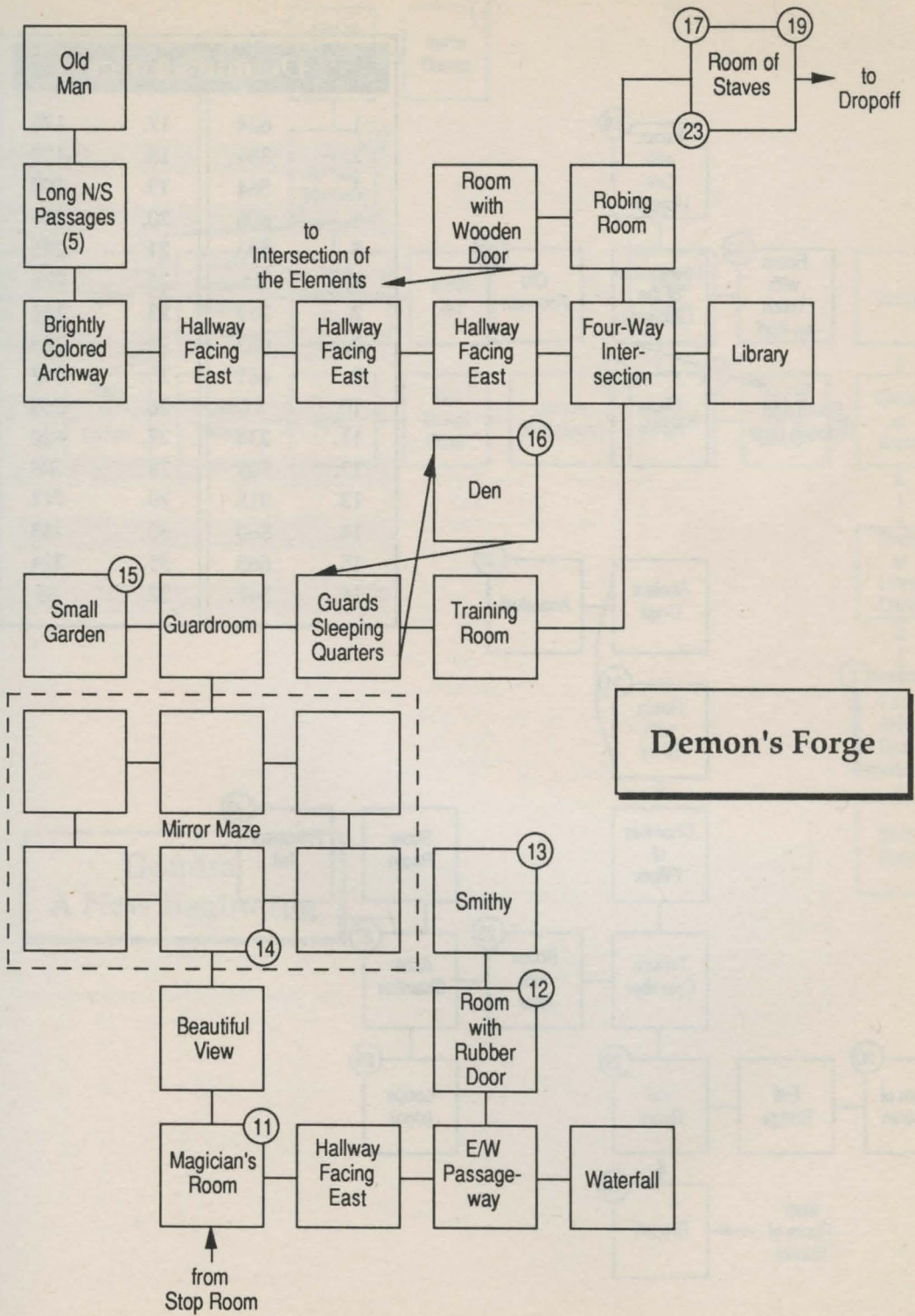

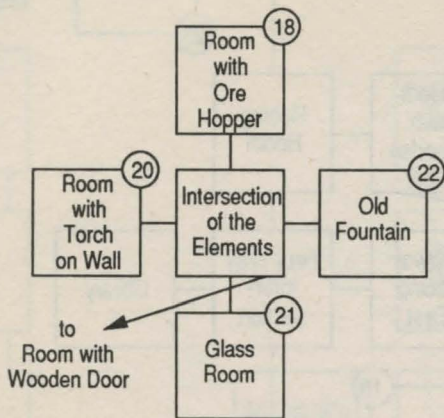

Demon's Forge			
1.	624	17.	176
2.	384	18.	137
3.	564	19.	500
4.	806	20.	296
5.	893	21.	285
6.	54	22.	776
7.	259	23.	144
8.	682	24.	189
9.	461	25.	147
10.	87	26.	368
11.	233	27.	620
12.	505	28.	308
13.	918	29.	742
14.	860	30.	143
15.	663	31.	324
16.	347	32.	88

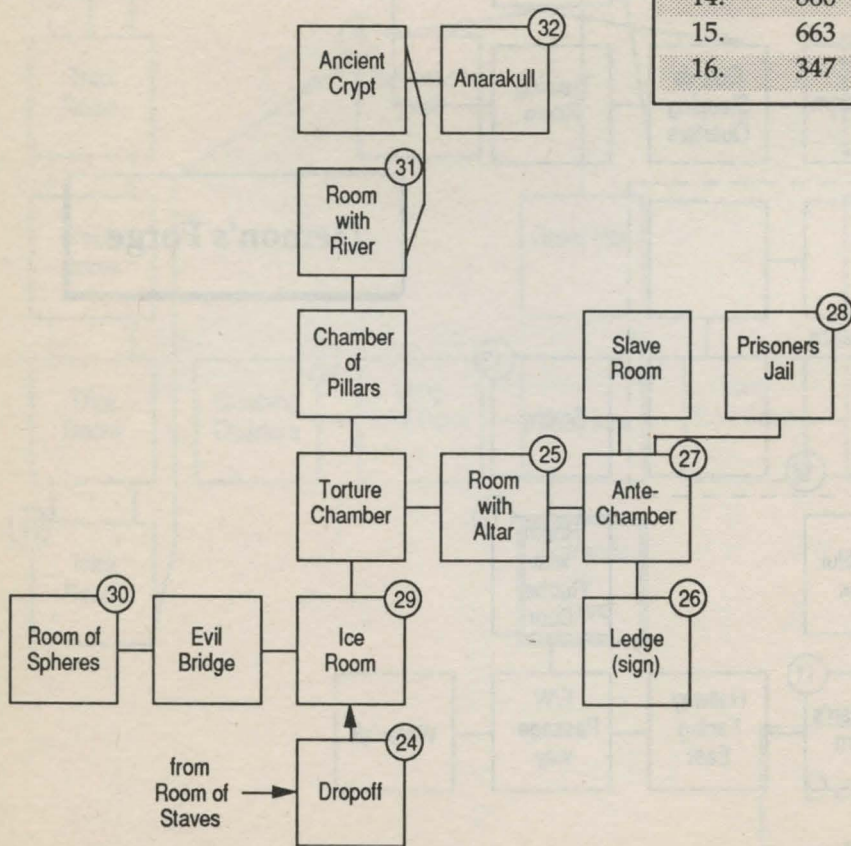

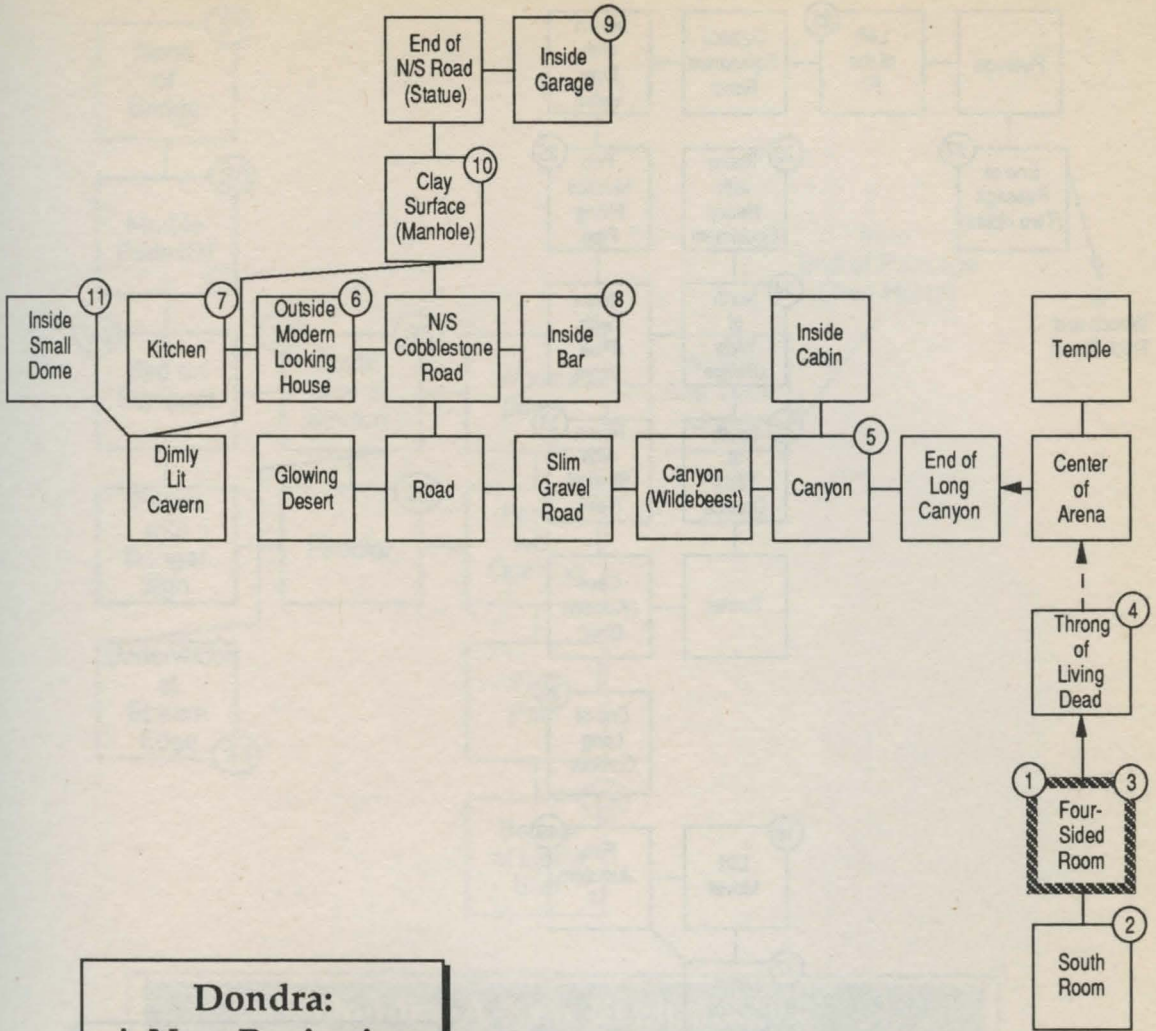

**Dondra:
A New Beginning**

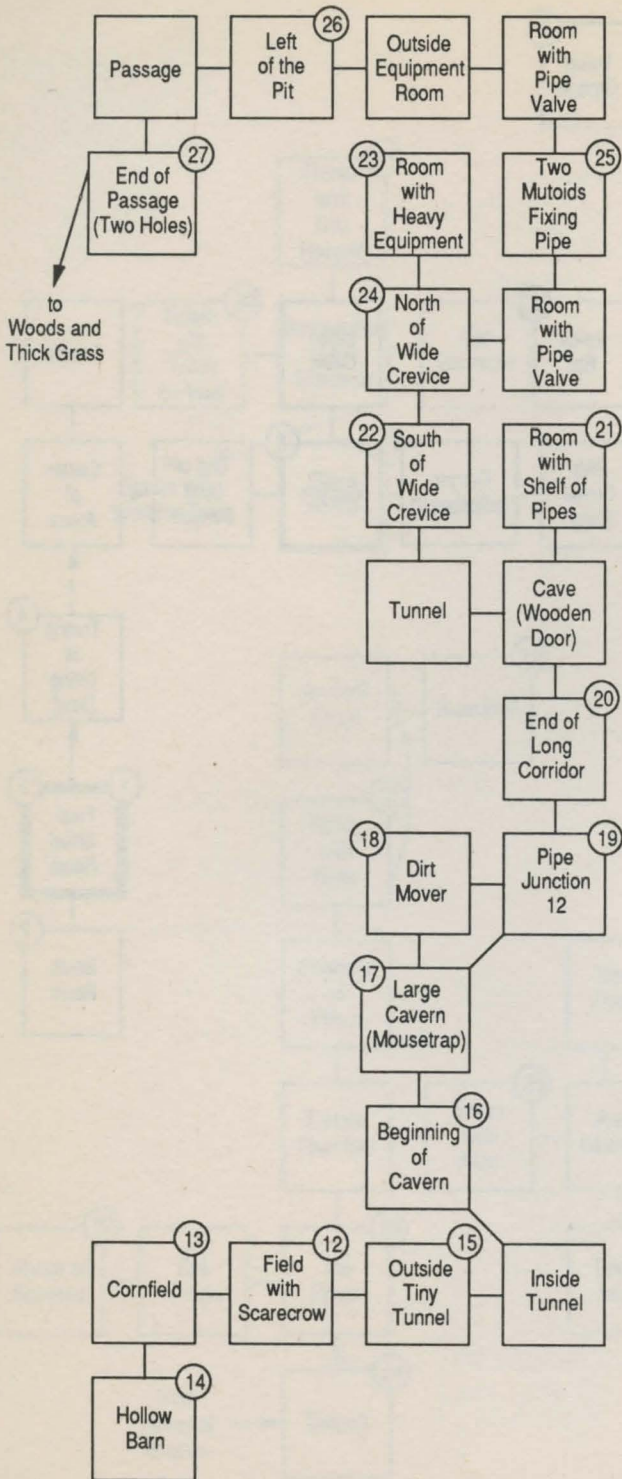

**Dondra:
A New Beginning**

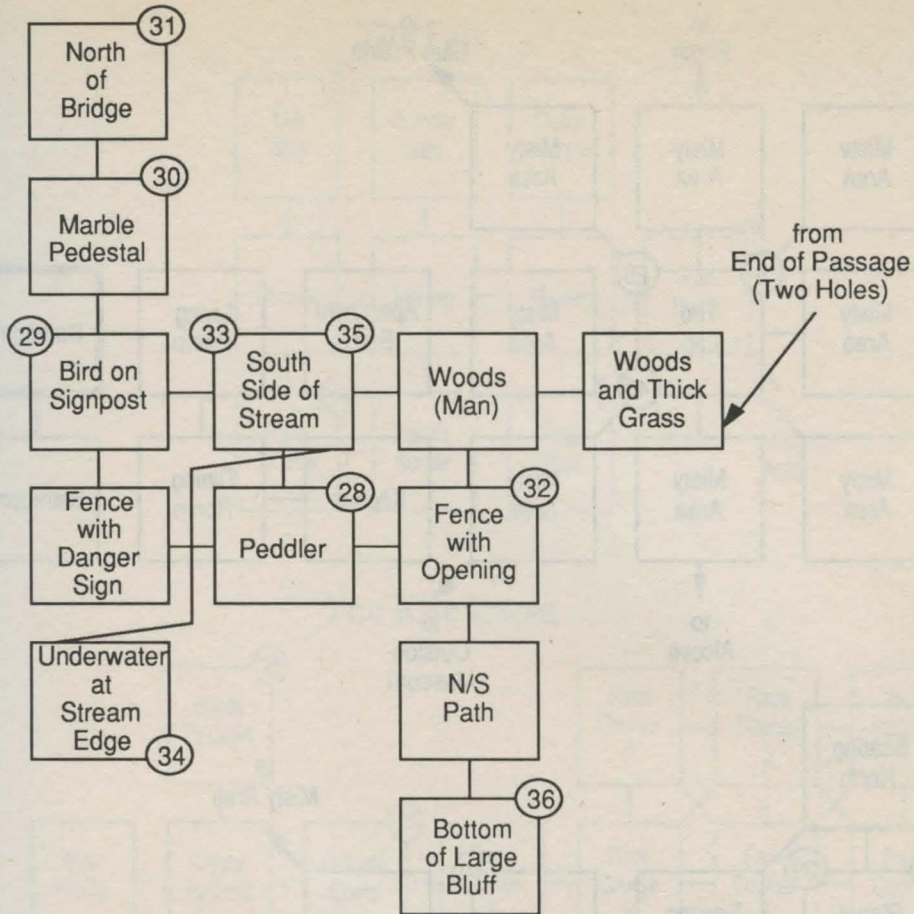

Dondra: A New Beginning

1.	864	13.	694	25.	218
2.	477	14.	180	26.	897
3.	847	15.	363	27.	277
4.	863	16.	482	28.	227
5.	641	17.	431	29.	396
6.	366	18.	303	30.	232
7.	808	19.	91	31.	94
8.	769	20.	800	32.	744
9.	871	21.	832	33.	892
10.	833	22.	193	34.	492
11.	358	23.	693	35.	724
12.	413	24.	807	36.	649

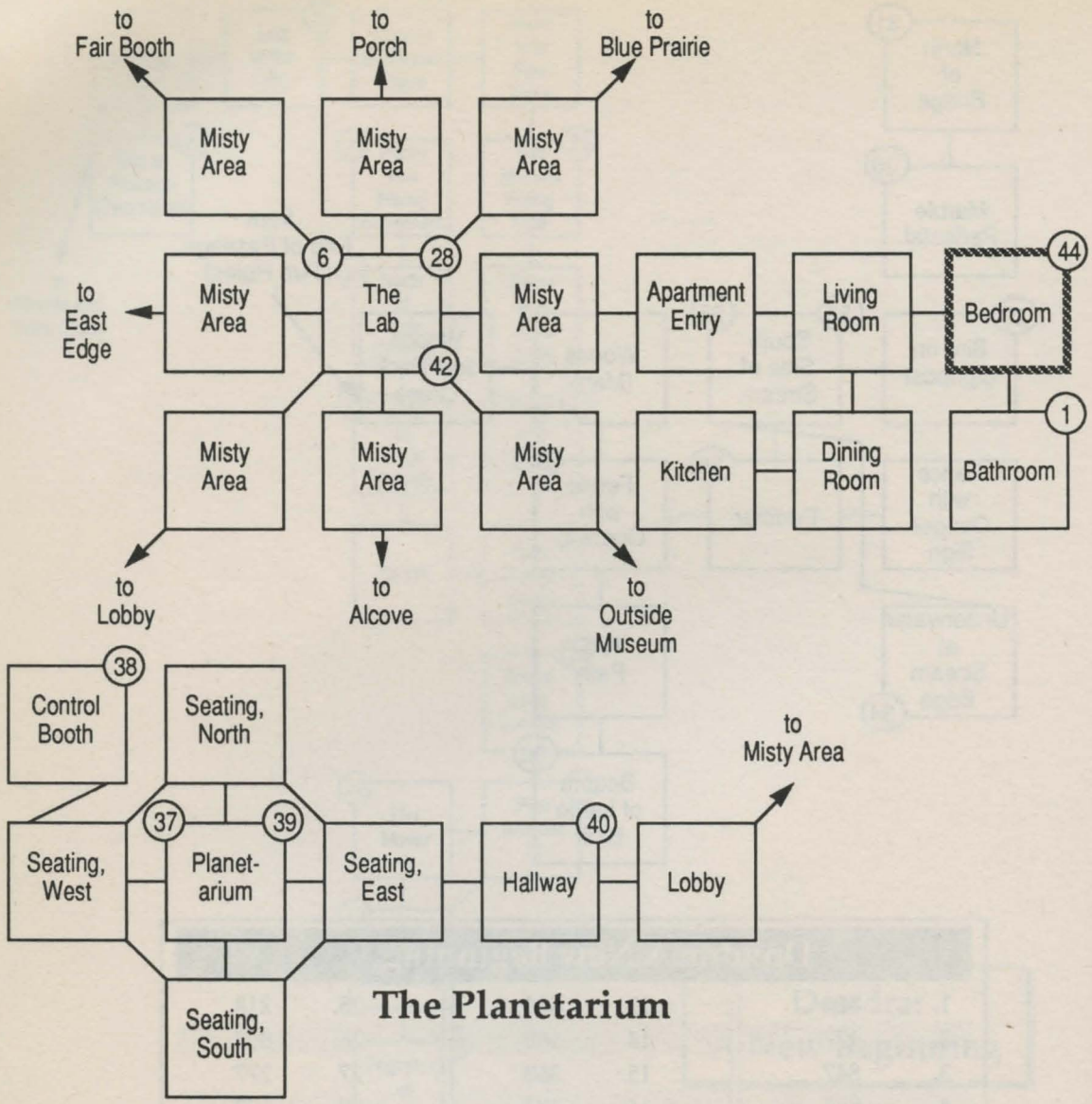

**Dr. Dumont's
Wild P.A.R.T.I.**

The Fair

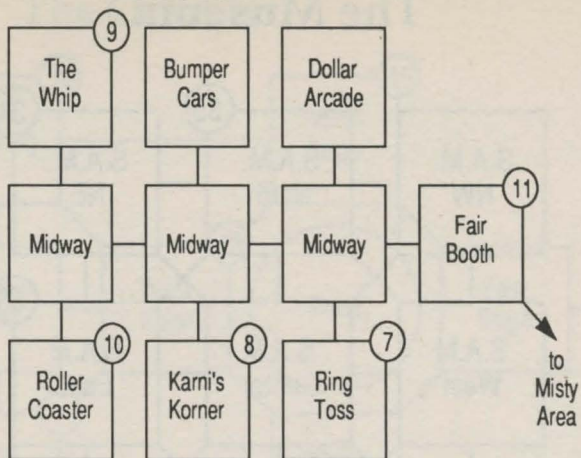

The Kite Races

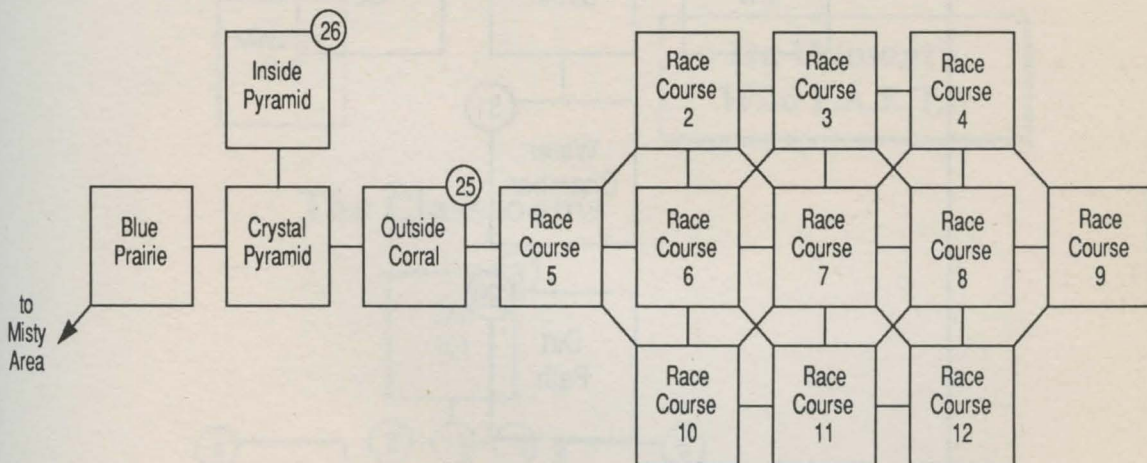

**Dr. Dumont's
Wild P.A.R.T.I.**

The Museum

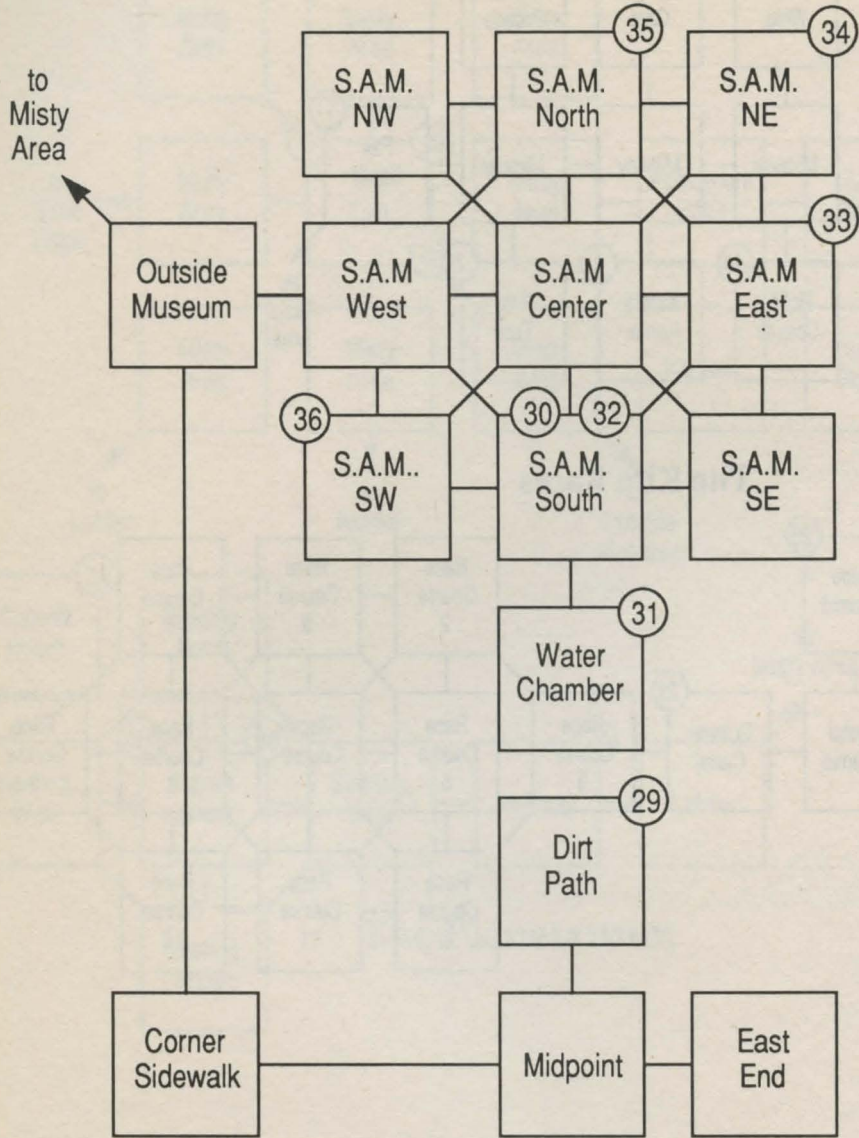

**Dr. Dumont's
Wild P.A.R.T.I.**

The Country

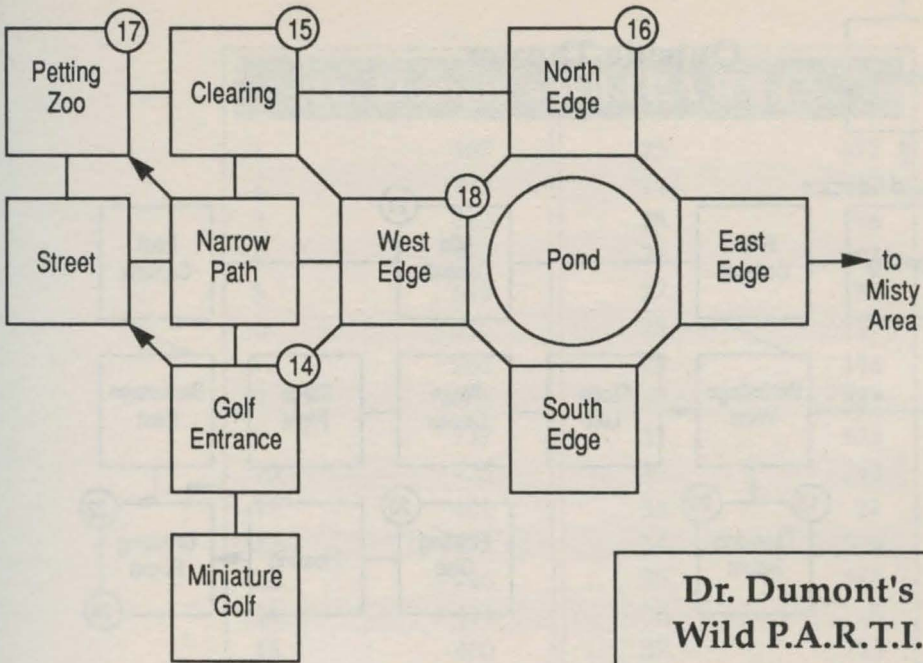

The Classrooms

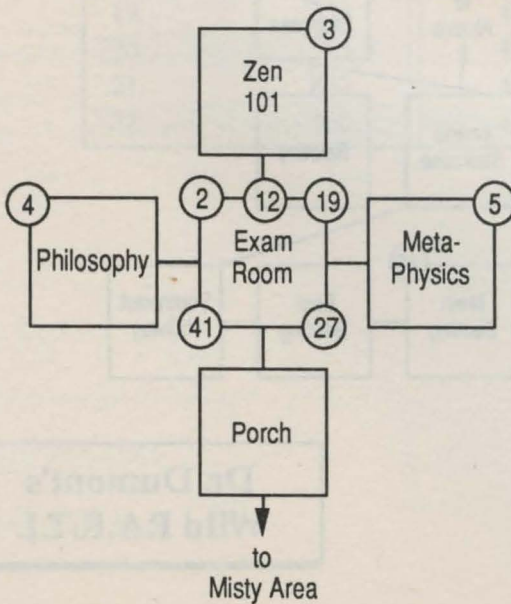

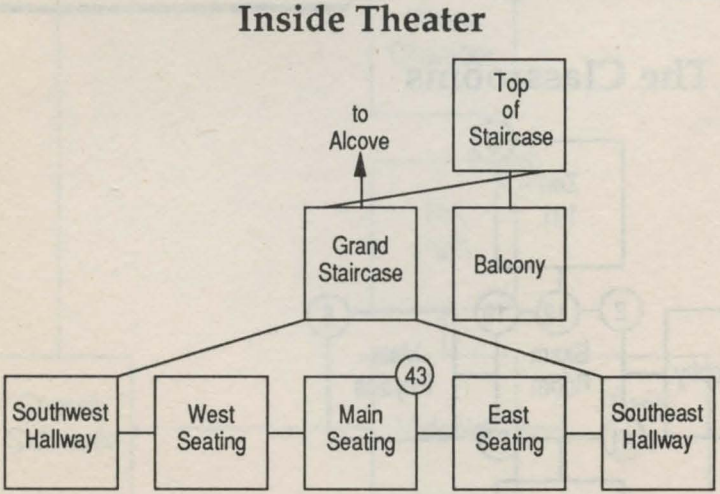
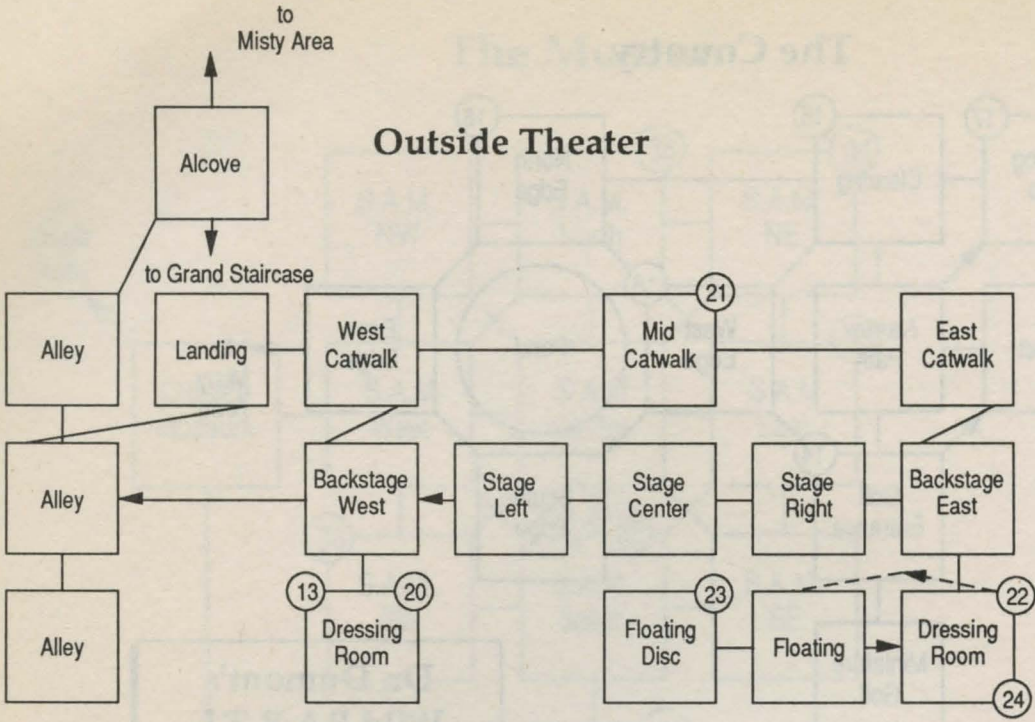

**Dr. Dumont's
Wild P.A.R.T.I.**

Dr. Dumont's Wild P.A.R.T.I.

1.	167	23.	672
2.	319	24.	517
3.	263	25.	786
4.	270	26.	281
5.	619	27.	781
6.	510	28.	197
7.	261	29.	114
8.	602	30.	581
9.	717	31.	436
10.	725	32.	249
11.	401	33.	21
12.	372	34.	526
13.	746	35.	868
14.	411	36.	6
15.	400	37.	723
16.	834	38.	670
17.	721	39.	446
18.	533	40.	700
19.	853	41.	85
20.	53	42.	705
21.	452	43.	283
22.	460	44.	313

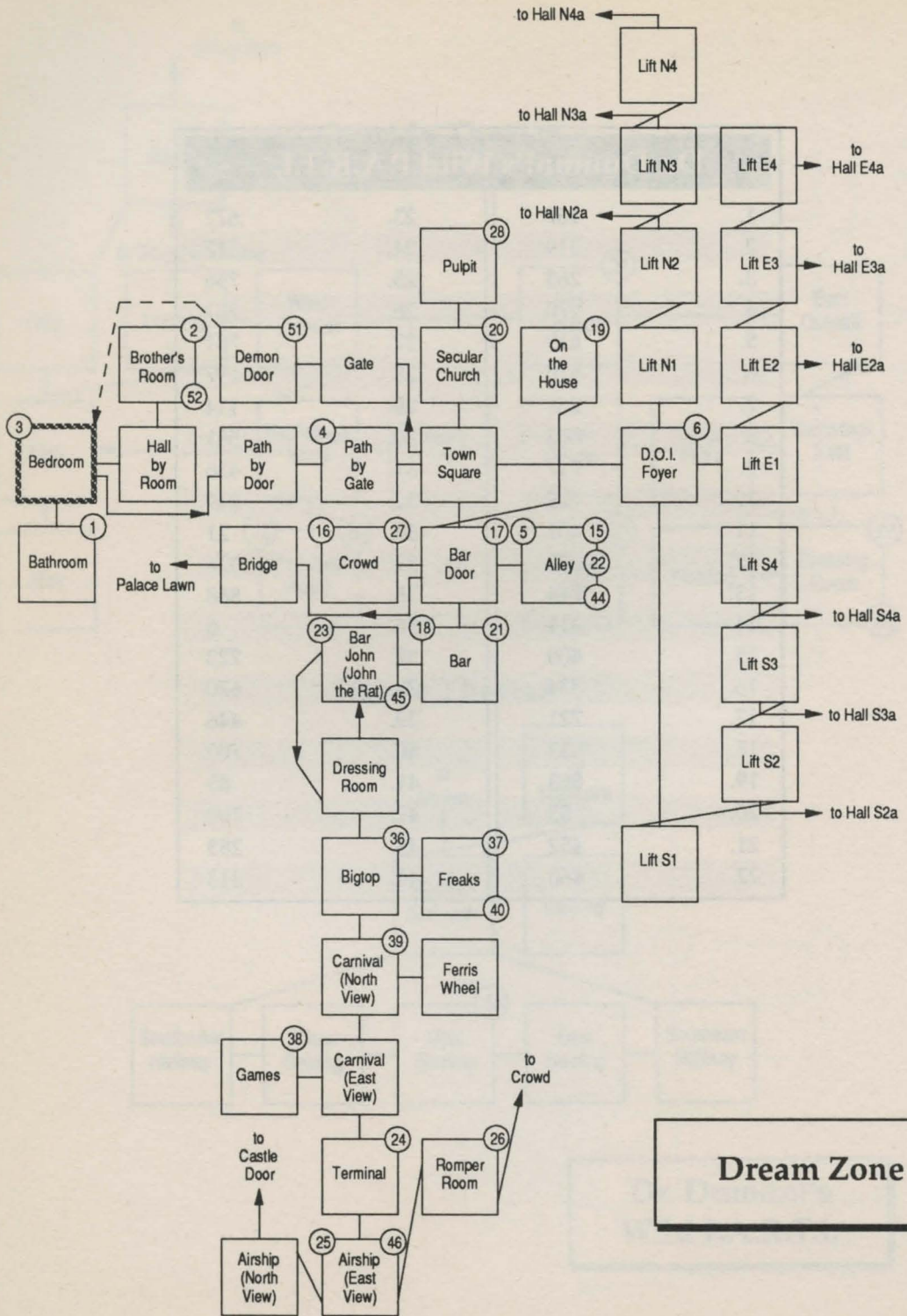

Dream Zone

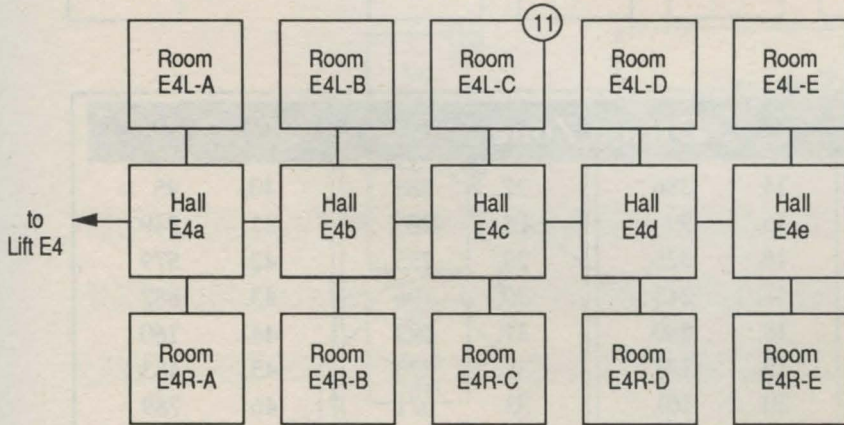
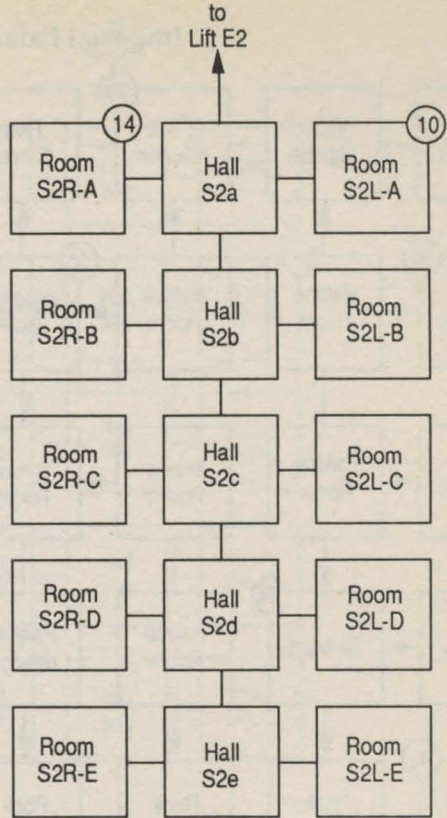
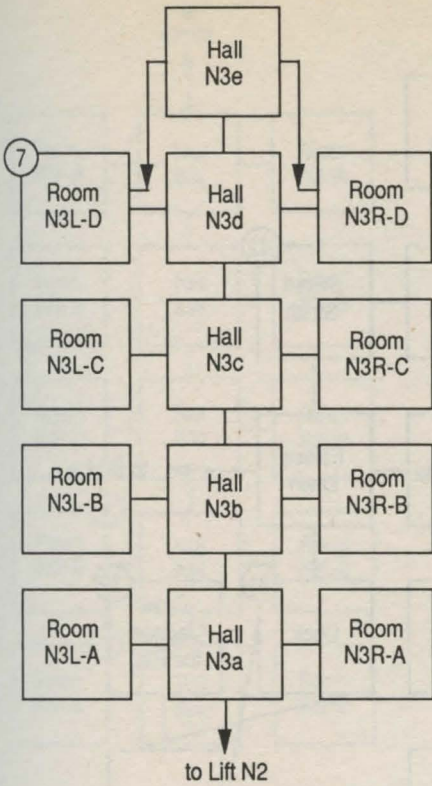

Dream Zone

Imperial Palace

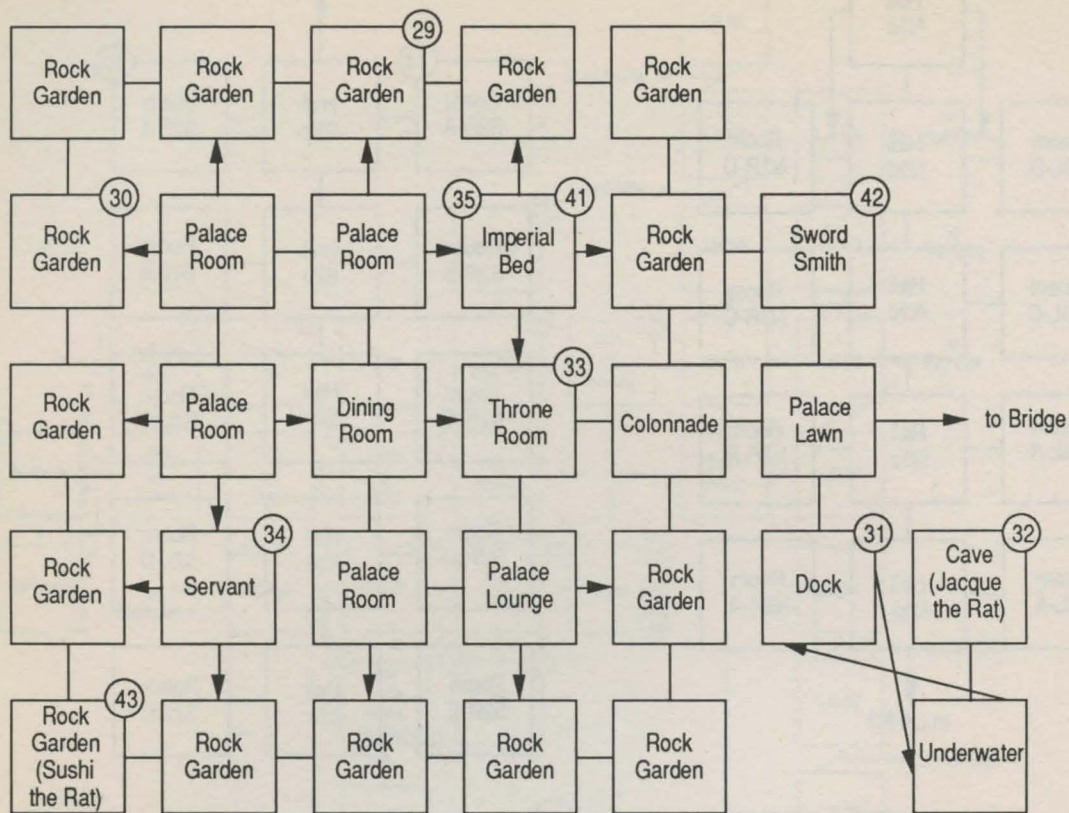

Dream Zone

1.	550	14.	386	27.	888	40.	95
2.	439	15.	99	28.	26	41.	849
3.	823	16.	326	29.	255	42.	579
4.	178	17.	243	30.	796	43.	887
5.	334	18.	880	31.	595	44.	160
6.	811	19.	174	32.	323	45.	483
7.	836	20.	161	33.	621	46.	789
8.	438	21.	674	34.	450	47.	667
9.	96	22.	757	35.	493	48.	531
10.	211	23.	287	36.	311	49.	241
11.	633	24.	592	37.	831	50.	816
12.	115	25.	269	38.	398	51.	55
13.	374	26.	229	39.	659	52.	643

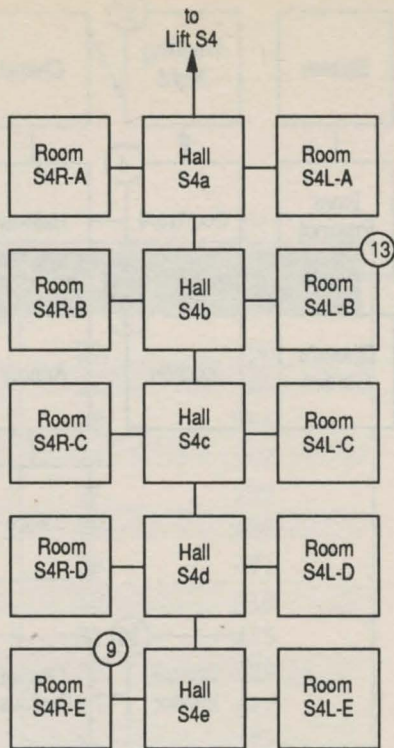
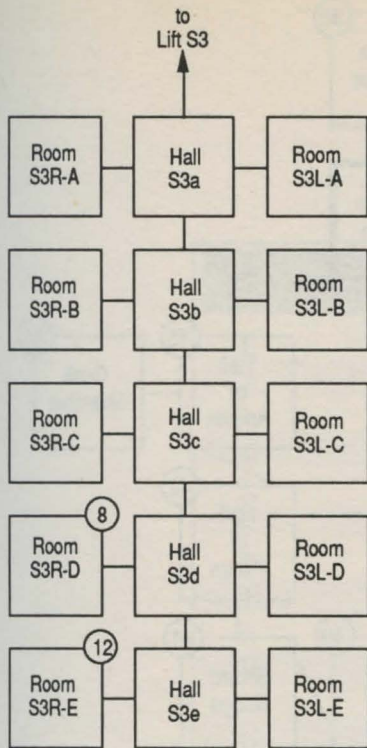

The Castle

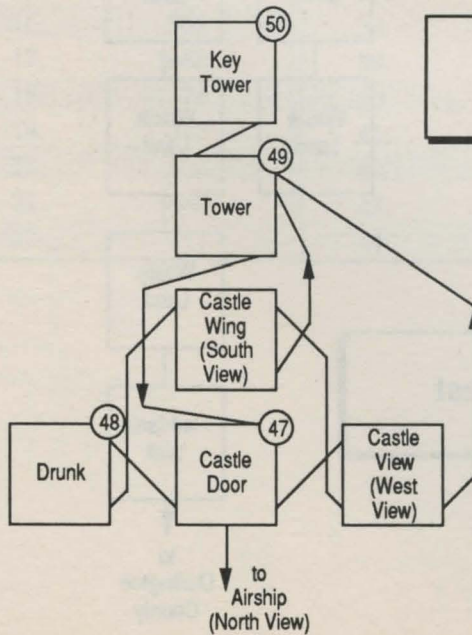

Dream Zone

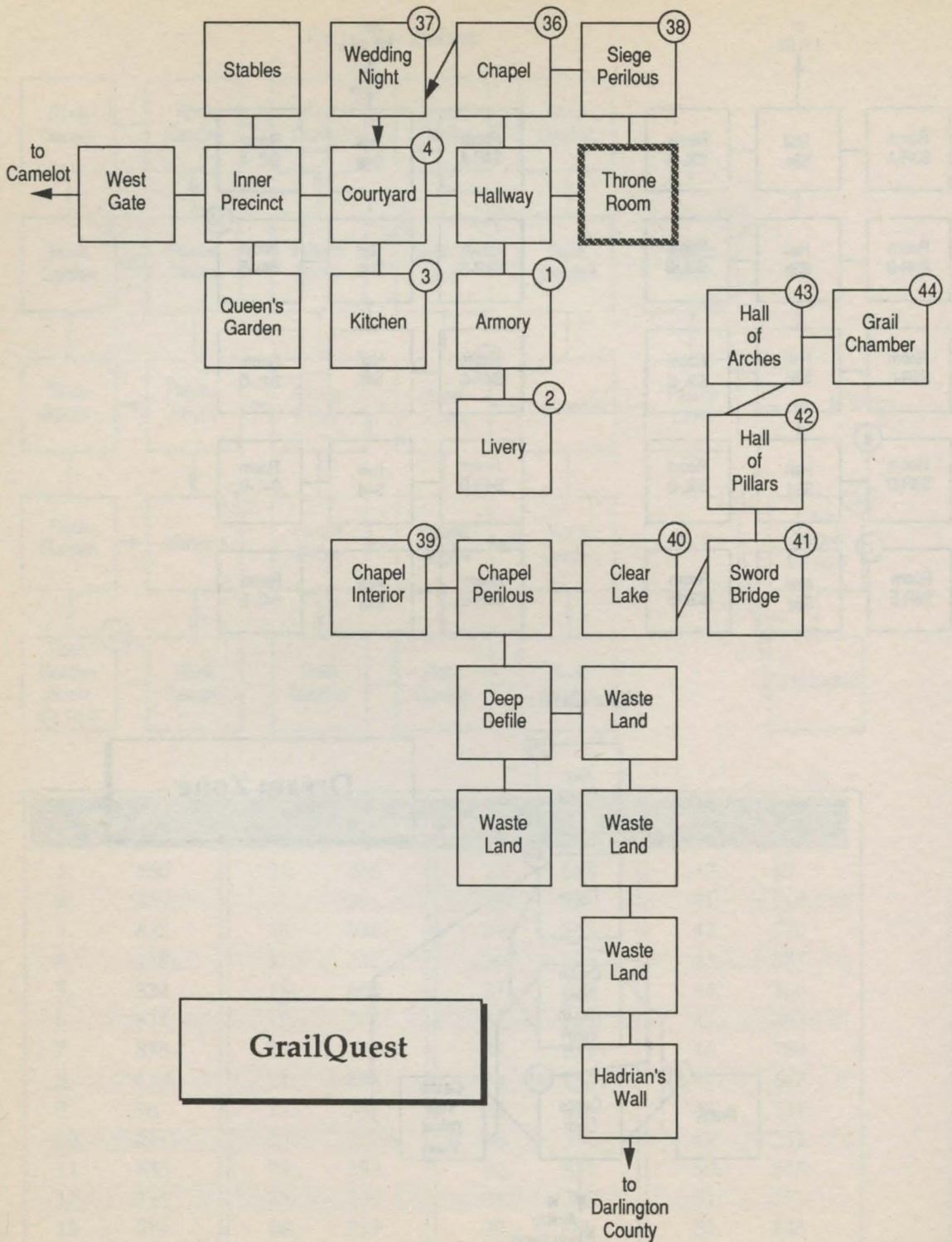

GrailQuest

1.	628	23.	196
2.	376	24.	68
3.	412	25.	766
4.	298	26.	907
5.	900	27.	729
6.	134	28.	635
7.	557	29.	491
8.	293	30.	618
9.	118	31.	415
10.	37	32.	329
11.	870	33.	647
12.	683	34.	172
13.	350	35.	449
14.	730	36.	665
15.	325	37.	375
16.	561	38.	206
17.	688	39.	34
18.	76	40.	432
19.	317	41.	475
20.	503	42.	655
21.	580	43.	854
22.	141	44.	58

GrailQuest

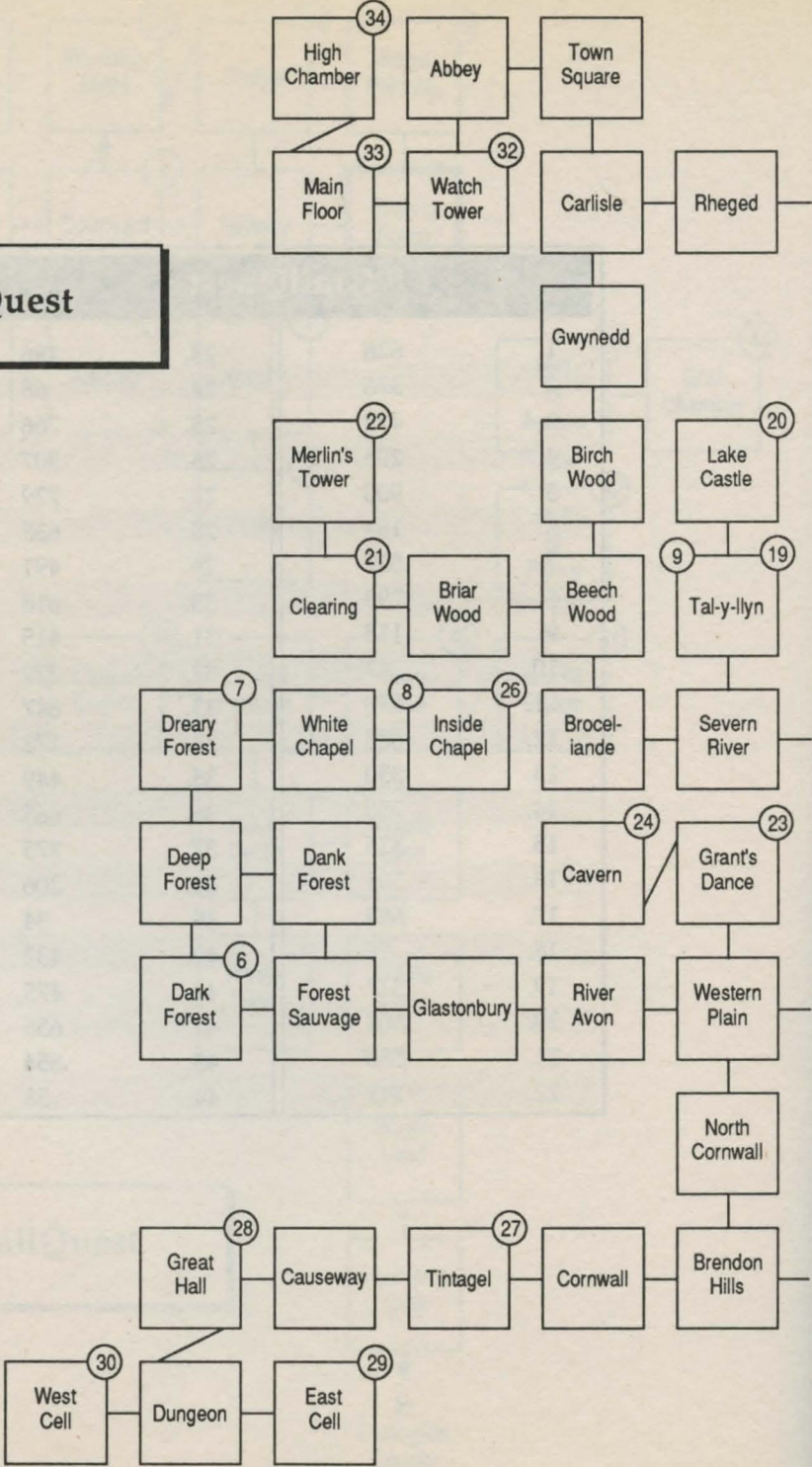

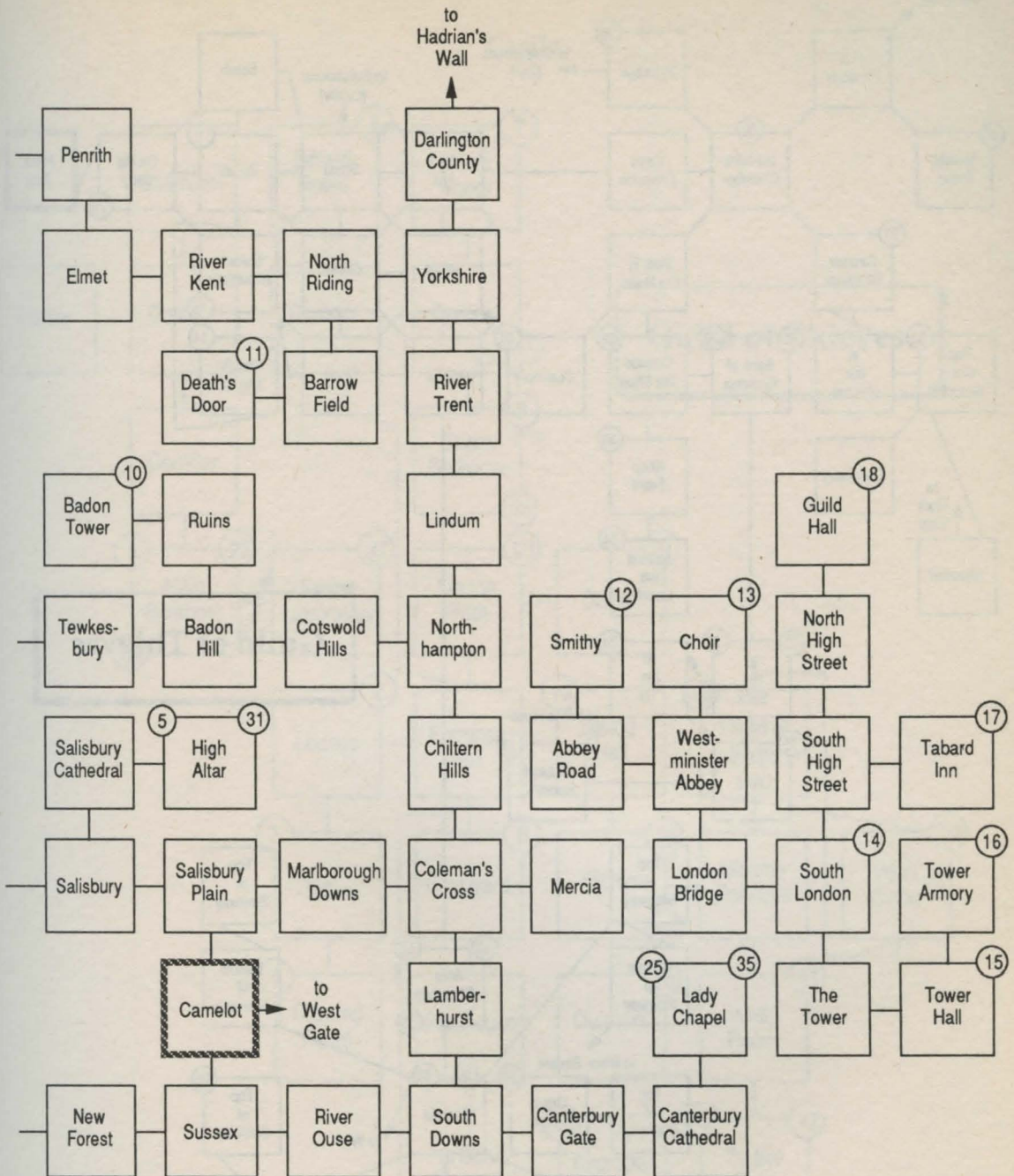

Kerovnia

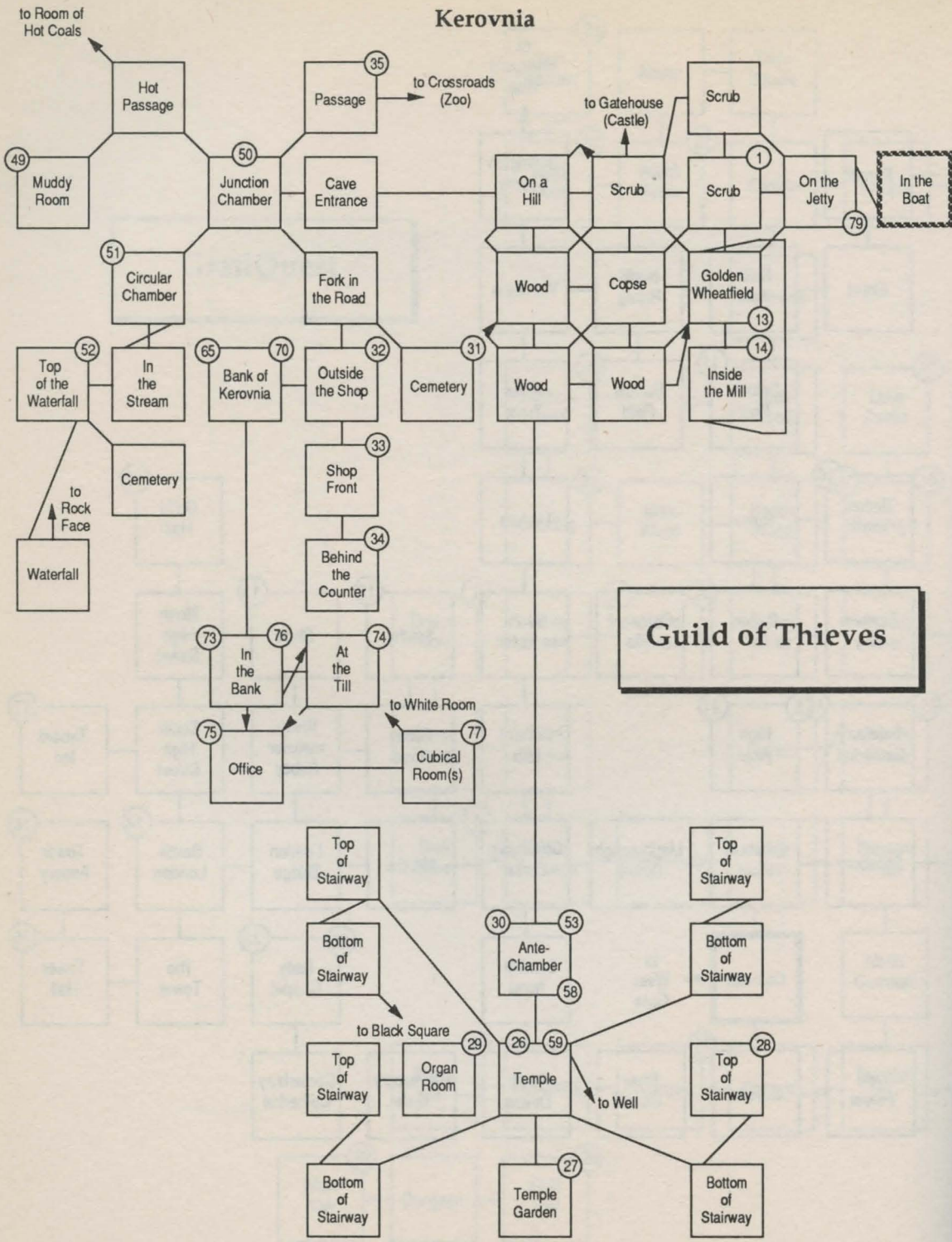

Castle

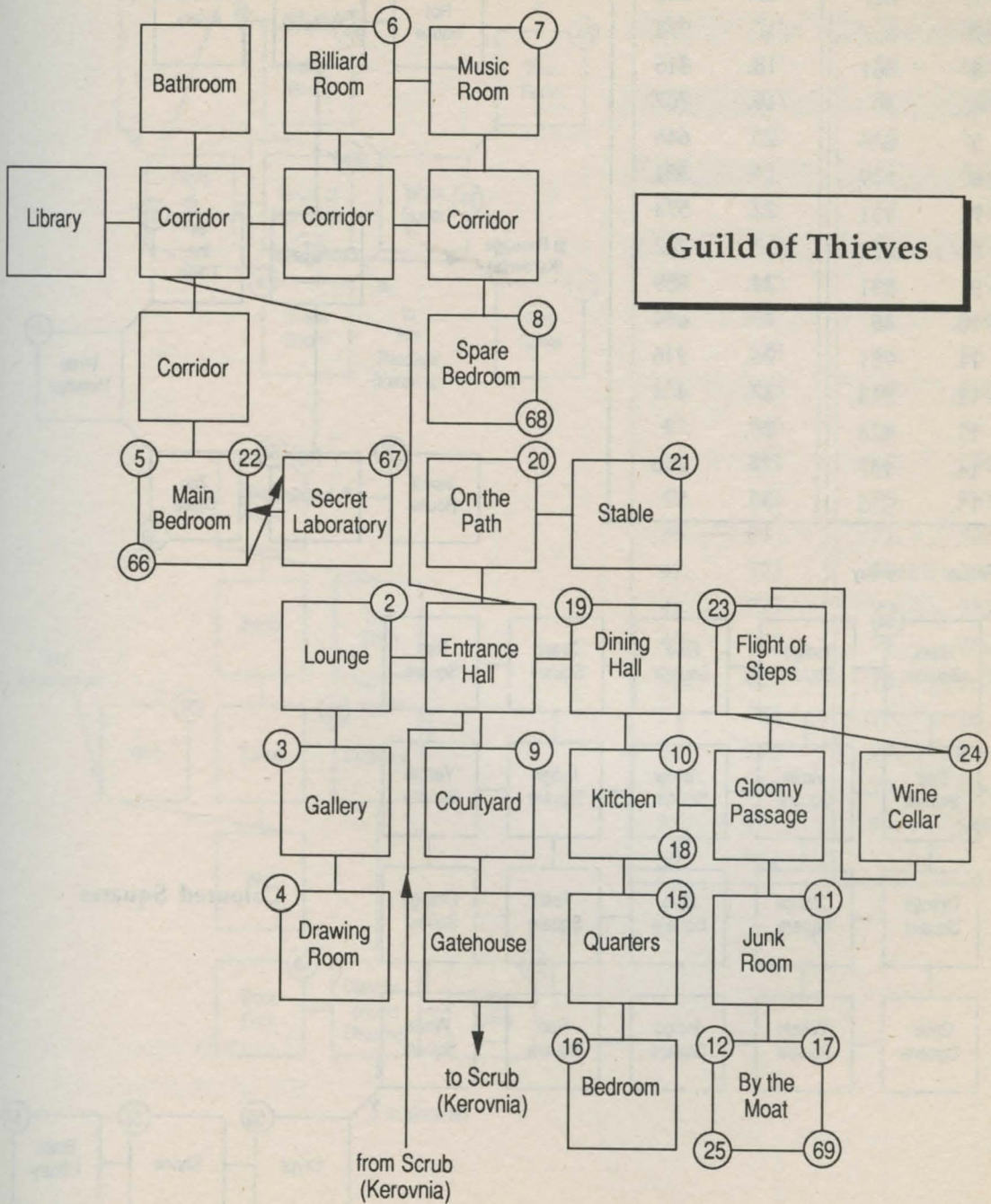

Guild of Thieves

1.	627	16.	246
2.	367	17.	914
3.	661	18.	316
4.	30	19.	707
5.	638	20.	646
6.	149	21.	351
7.	131	22.	574
8.	873	23.	238
9.	331	24.	859
10.	45	25.	614
11.	751	26.	916
12.	513	27.	464
13.	428	28.	78
14.	157	29.	216
15.	335	30.	52

Zoo

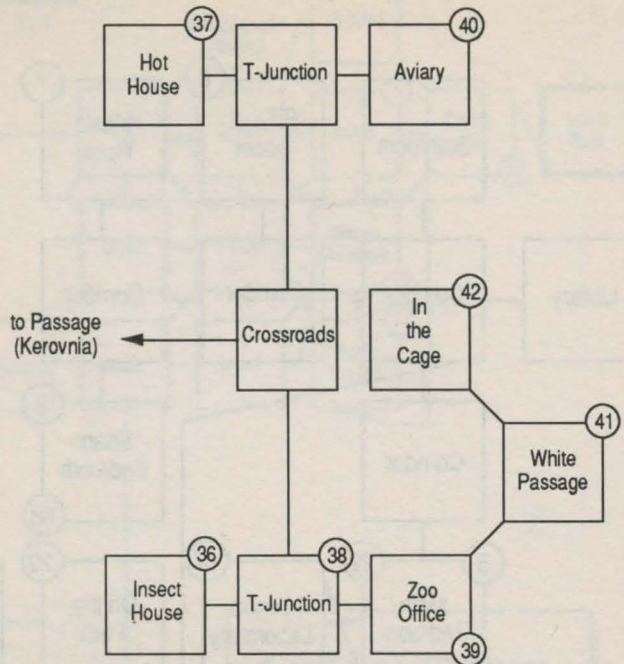

to Bottom of Stairway

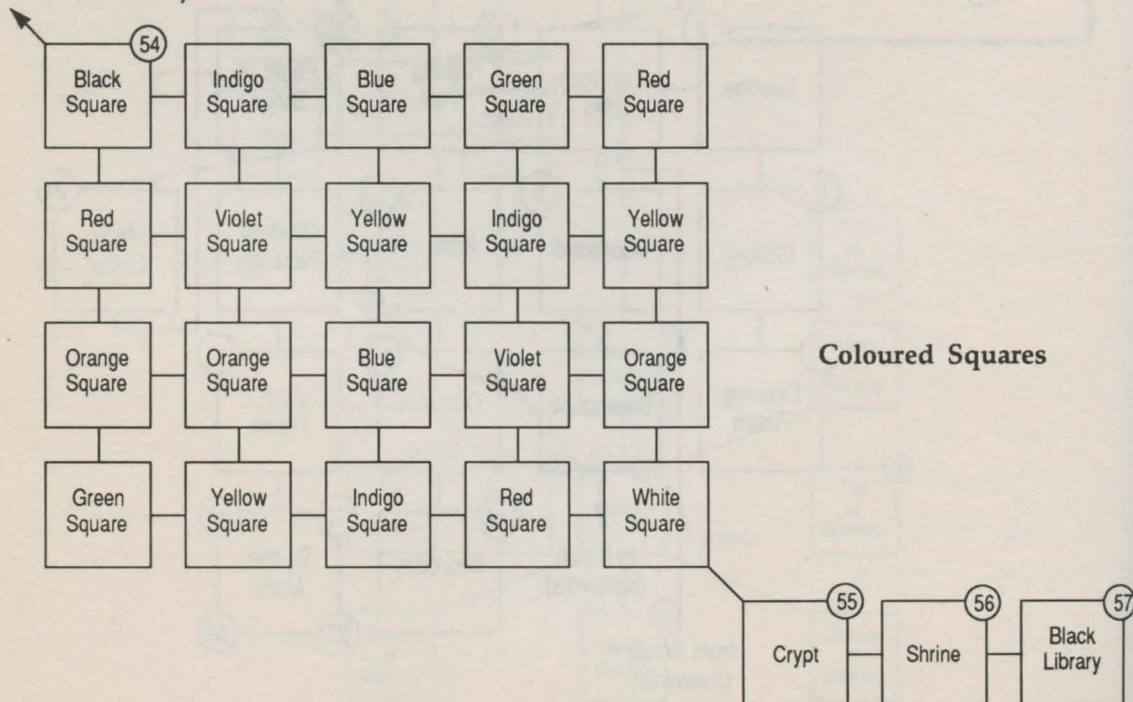

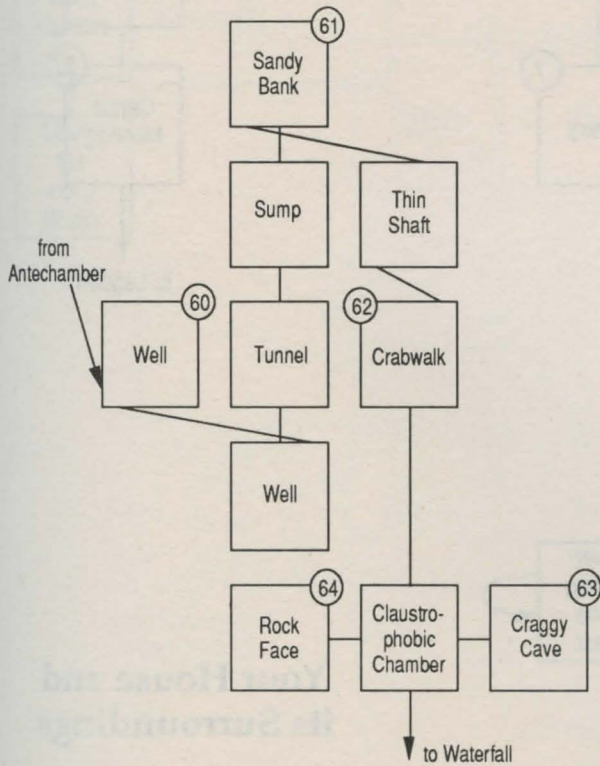
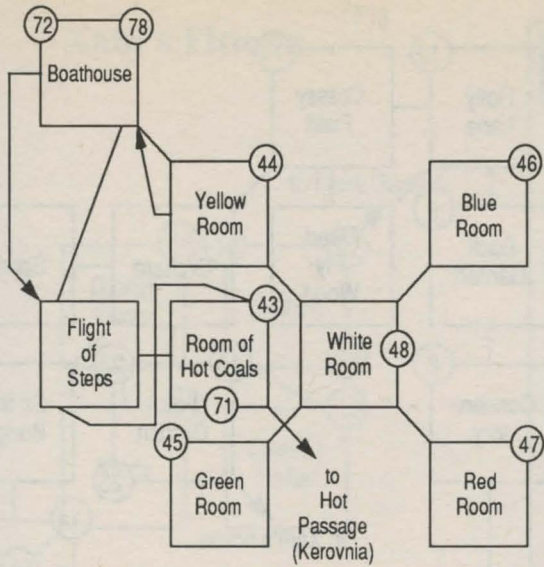

Guild of Thieves

31.	519	56.	821
32.	634	57.	338
33.	422	58.	629
34.	123	59.	109
35.	340	60.	5
36.	16	61.	547
37.	202	62.	543
38.	902	63.	337
39.	445	64.	570
40.	467	65.	866
41.	678	66.	867
42.	738	67.	282
43.	666	68.	877
44.	891	69.	559
45.	111	70.	758
46.	84	71.	728
47.	373	72.	598
48.	777	73.	223
49.	257	74.	760
50.	686	75.	567
51.	788	76.	18
52.	775	77.	4
53.	355	78.	536
54.	1	79.	845
55.	824		

Jinxter

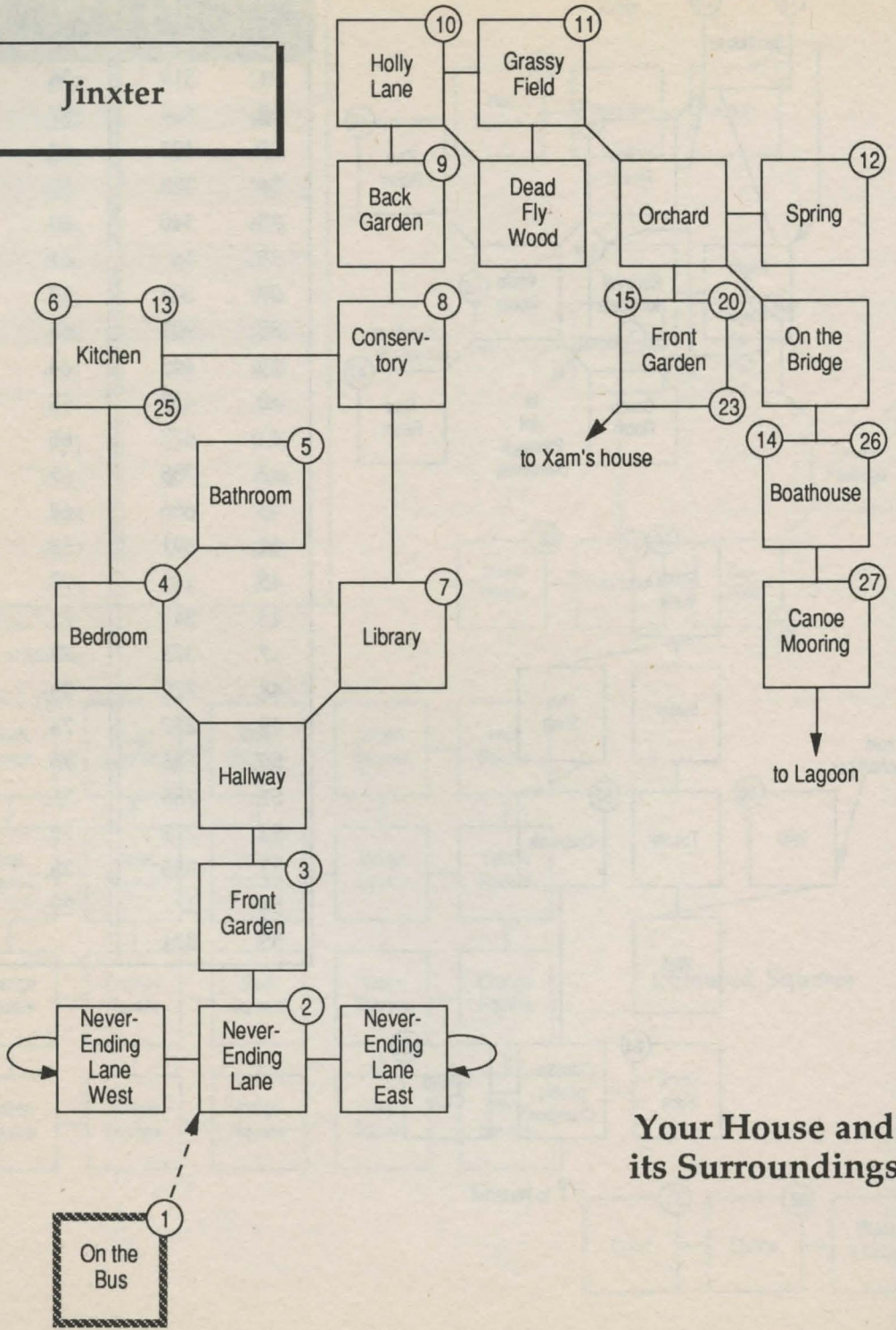

Your House and its Surroundings

Xam's House

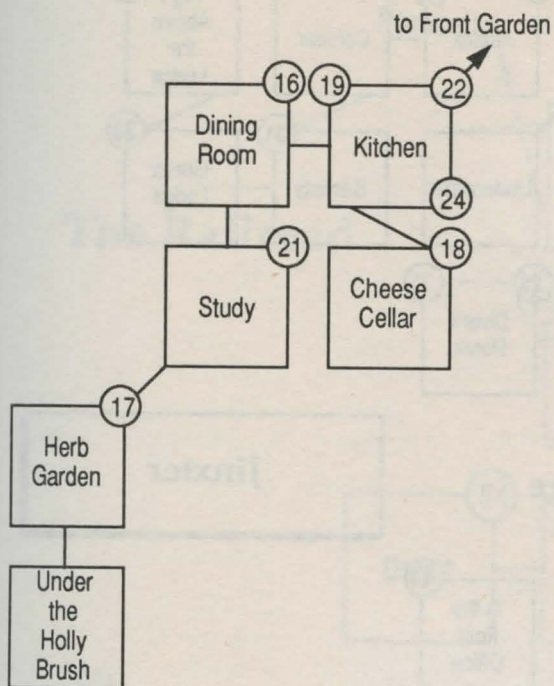

Jinxter

1.	145	32.	49
2.	394	33.	379
3.	599	34.	43
4.	601	35.	875
5.	770	36.	798
6.	905	37.	299
7.	107	38.	851
8.	511	39.	695
9.	20	40.	288
10.	93	41.	679
11.	345	42.	433
12.	583	43.	696
13.	676	44.	14
14.	691	45.	587
15.	755	46.	369
16.	182	47.	441
17.	97	48.	170
18.	790	49.	407
19.	105	50.	722
20.	51	51.	515
21.	385	52.	518
22.	24	53.	471
23.	100	54.	248
24.	878	55.	10
25.	473	56.	736
26.	121	57.	353
27.	165	58.	677
28.	743	59.	551
29.	617	60.	861
30.	79	61.	205
31.	689	62.	538

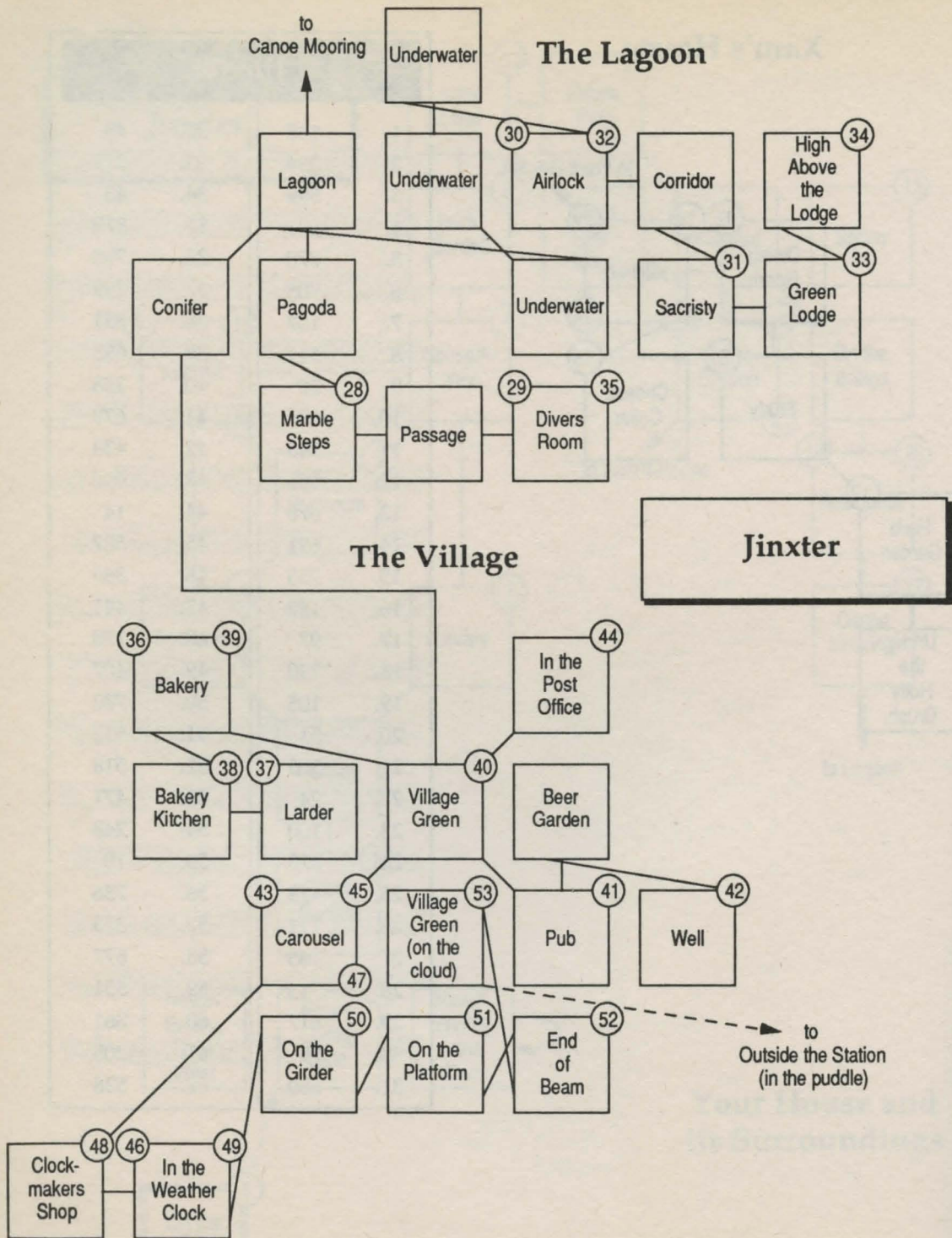

The Railroad

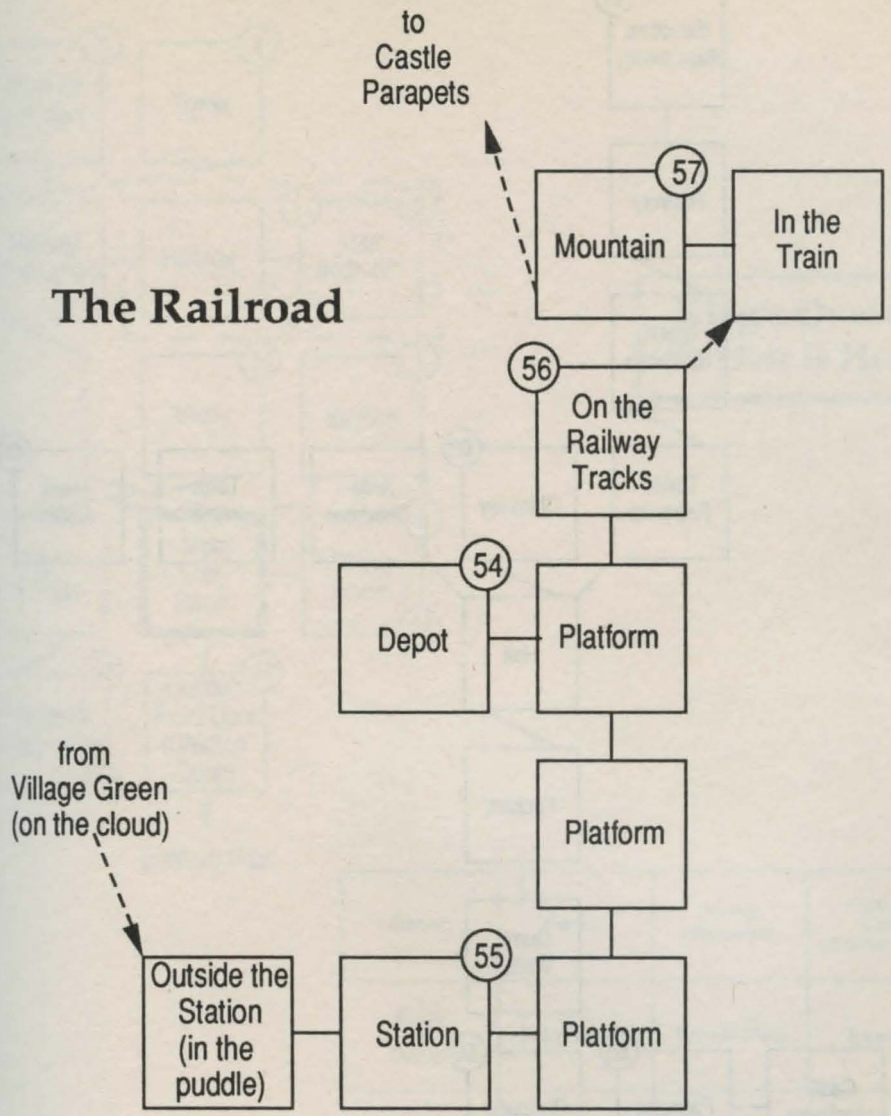

Jinxter

The Castle

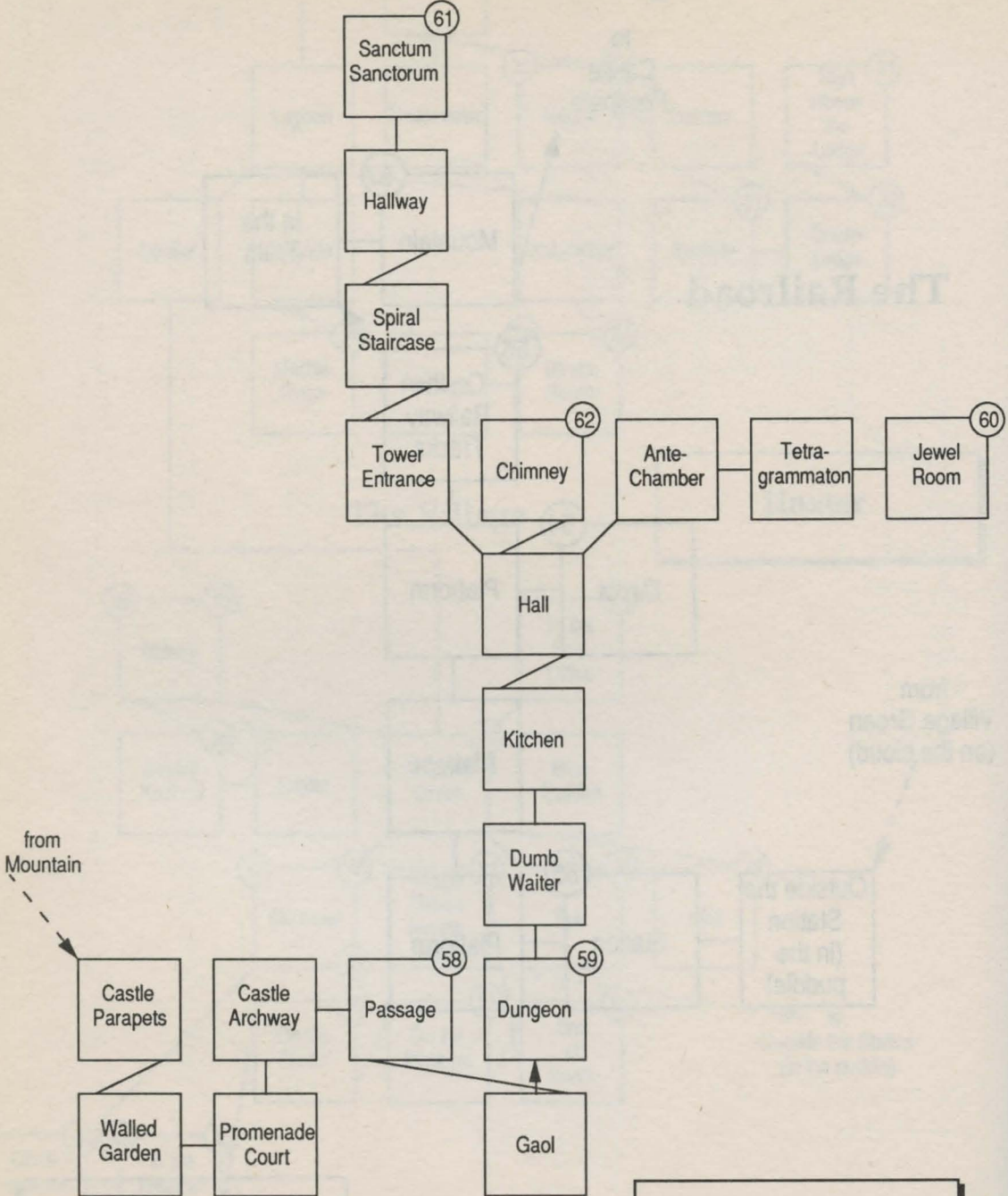

Jinxter

Manannan's House

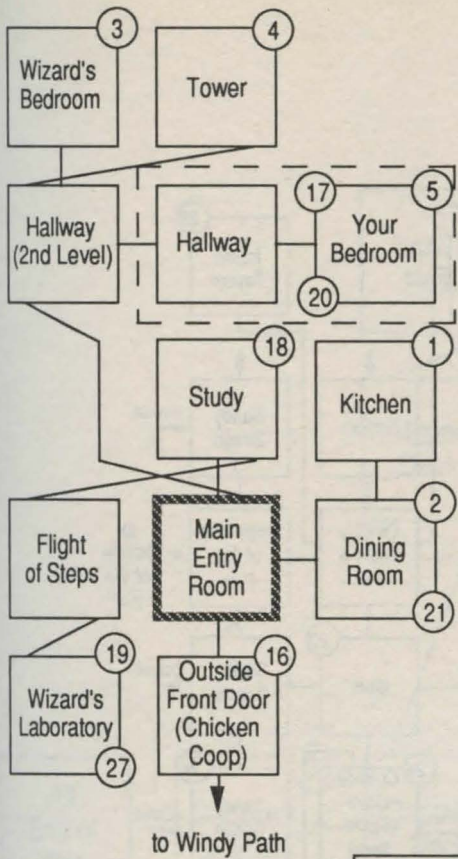

King's Quest III: To Heir is Human

Desert	Forest	Forest (Waterfall)	Outside Cave (Spider Web)	Sandy Beach
Edge of Desert	Forest	Forest Floor	Stream	Sandy Beach
Desert (Large Rock)	Forest (Large Oak Tree)	Forest	Outside Store & Tavern	Beginning of the Pier
Edge of Desert	Forest	Outside Three Bears House	Bluff	Sandy Beach

Magic Map

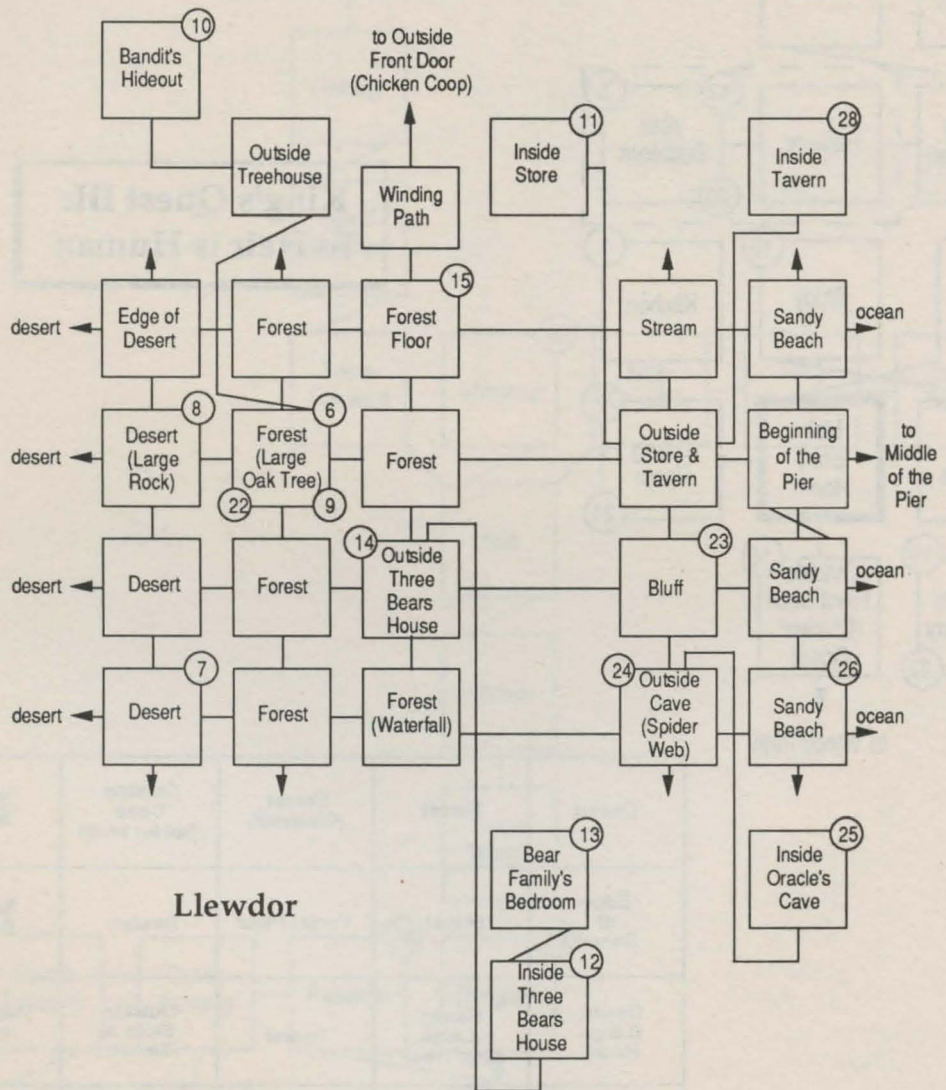

Llewddor

**Kings Quest III:
To Heir is Human**

King's Quest III: To Heir is Human

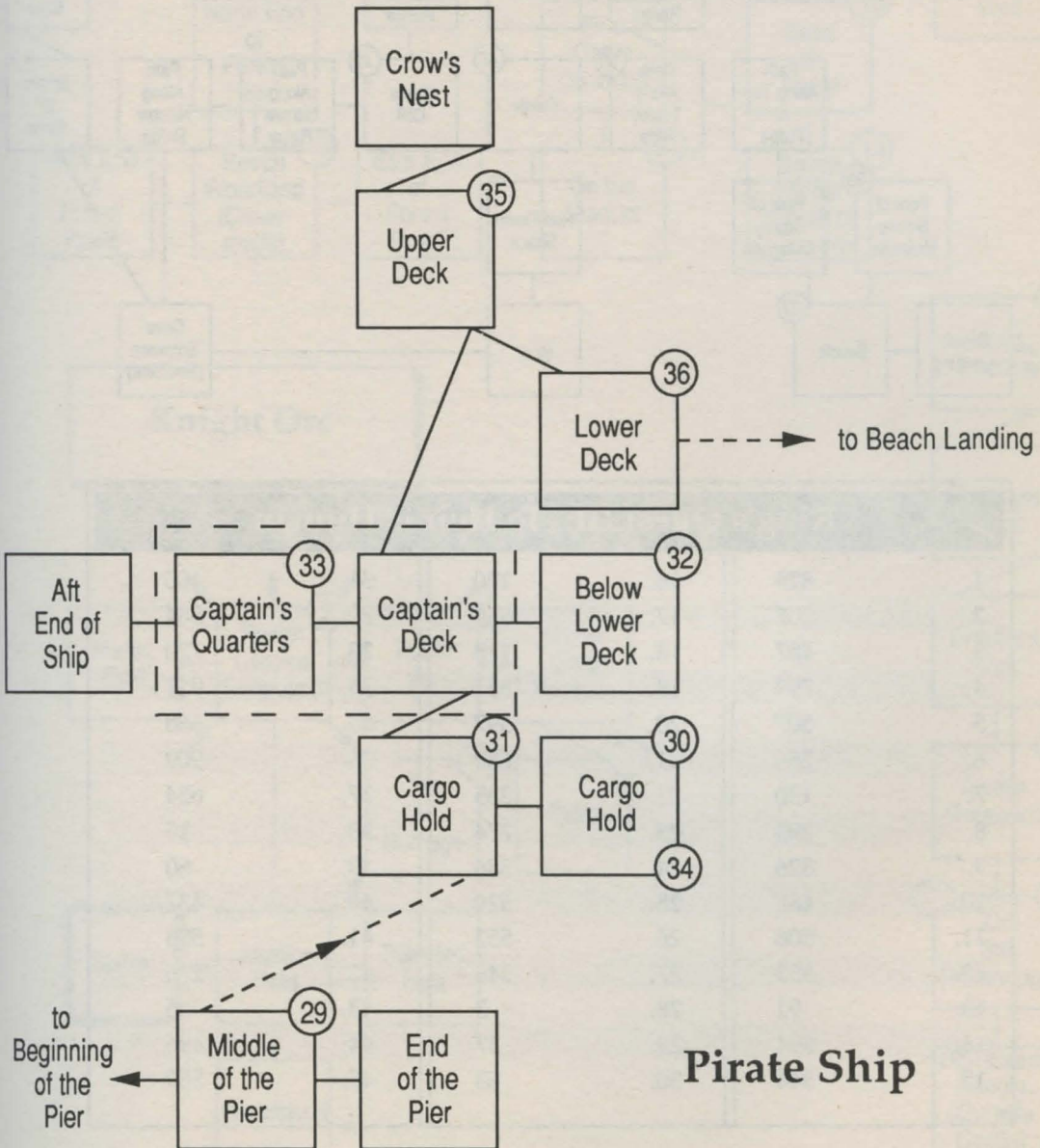

En Route to Daventry

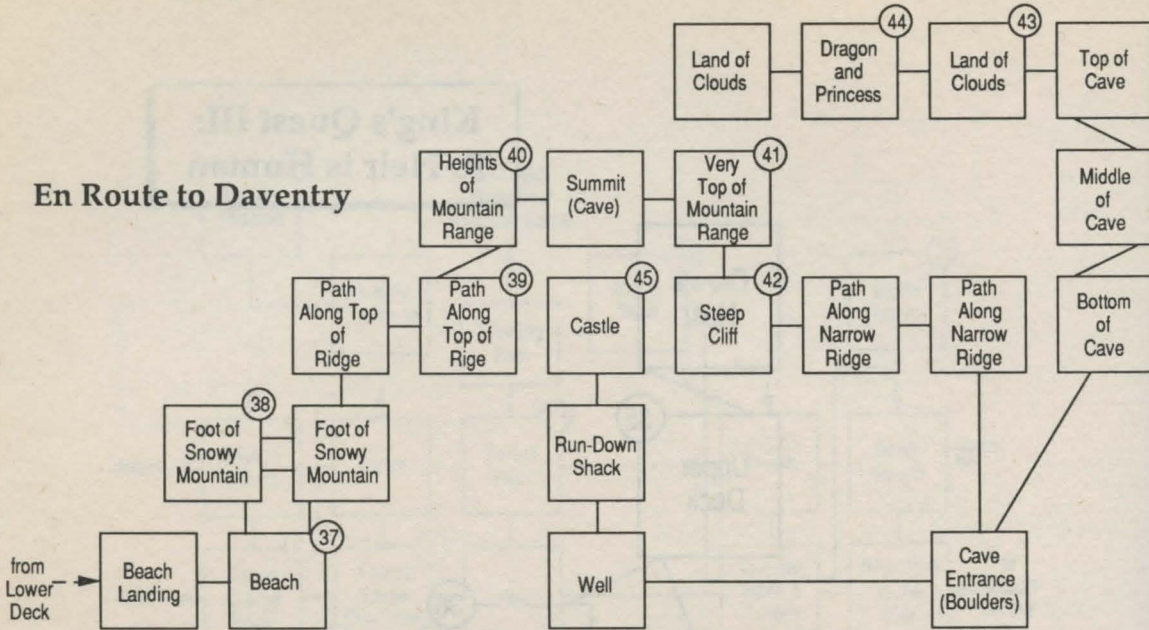

King's Quest III: To Heir is Human

1.	829	16.	120	31.	405
2.	207	17.	565	32.	584
3.	487	18.	188	33.	720
4.	799	19.	554	34.	911
5.	507	20.	397	35.	668
6.	256	21.	632	36.	909
7.	130	22.	235	37.	654
8.	295	23.	774	38.	15
9.	826	24.	586	39.	60
10.	488	25.	529	40.	437
11.	506	26.	552	41.	593
12.	855	27.	346	42.	210
13.	92	28.	3	43.	365
14.	894	29.	57	44.	496
15.	844	30.	63	45.	589

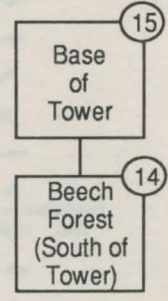
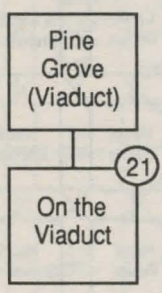
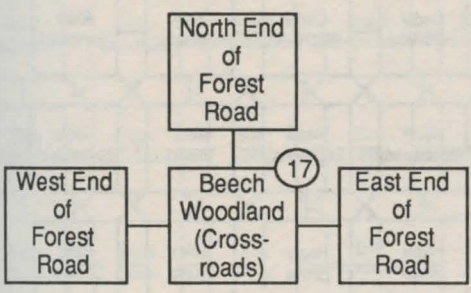
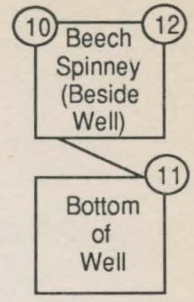
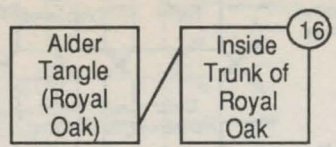
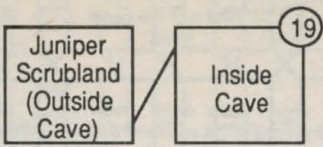

Knight Orc

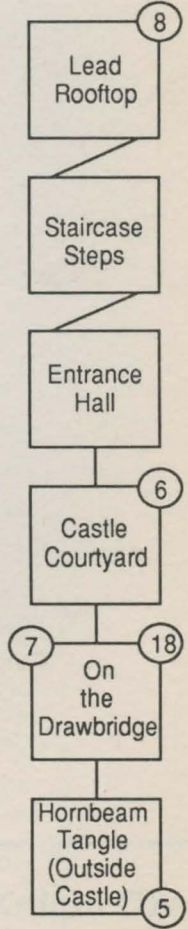
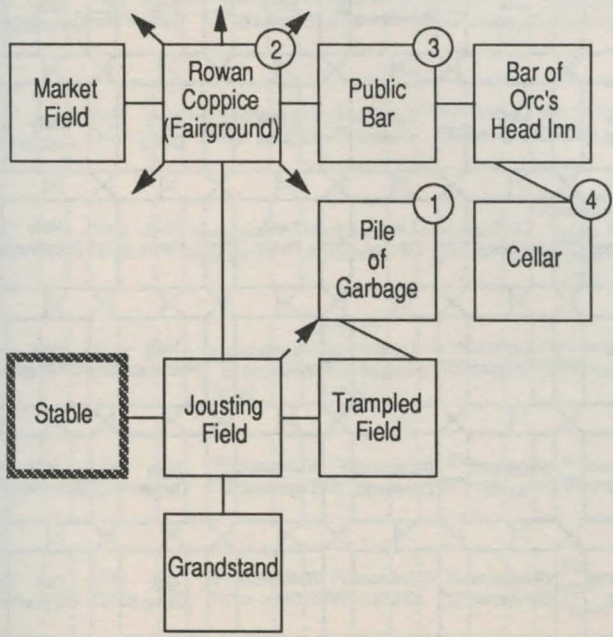

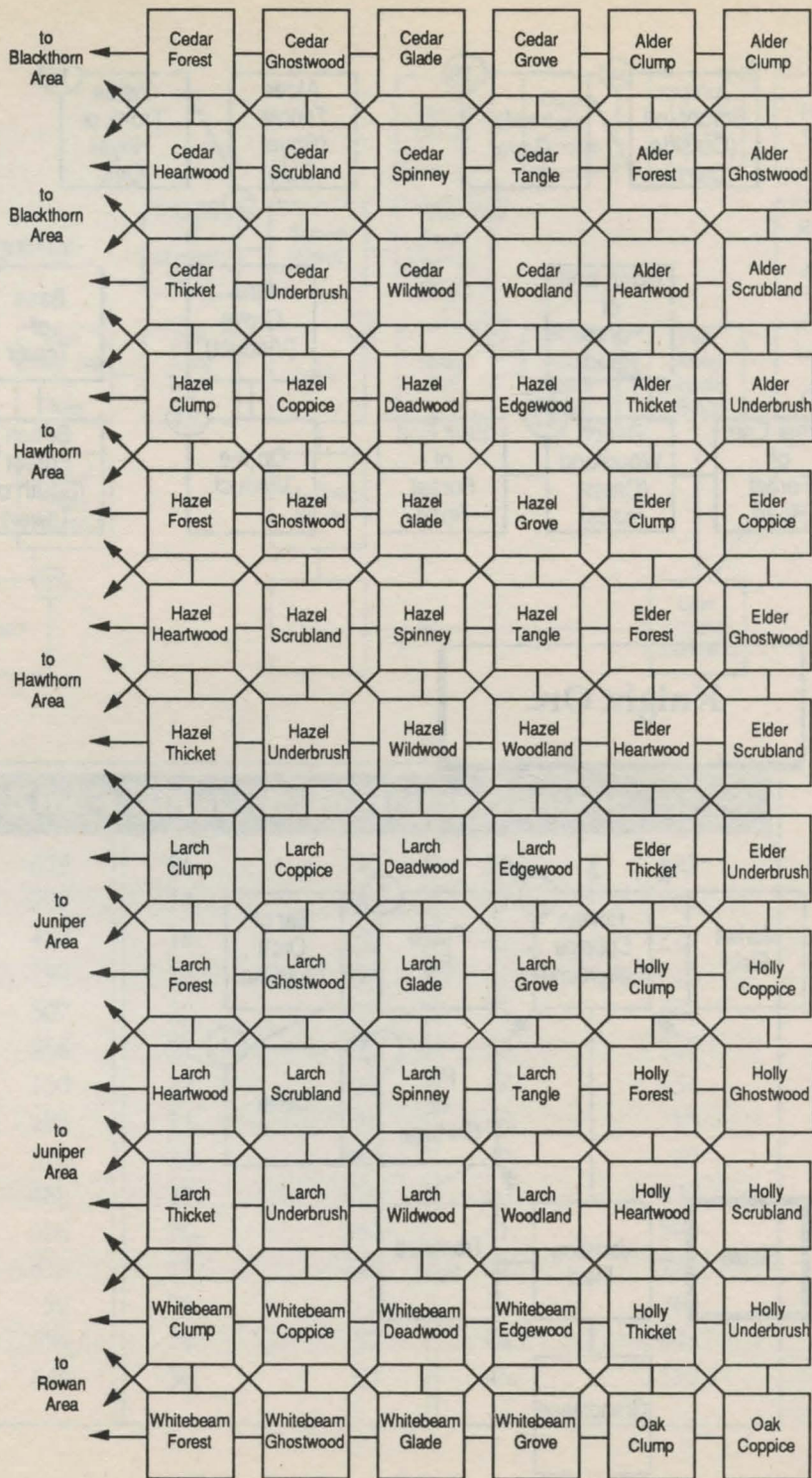

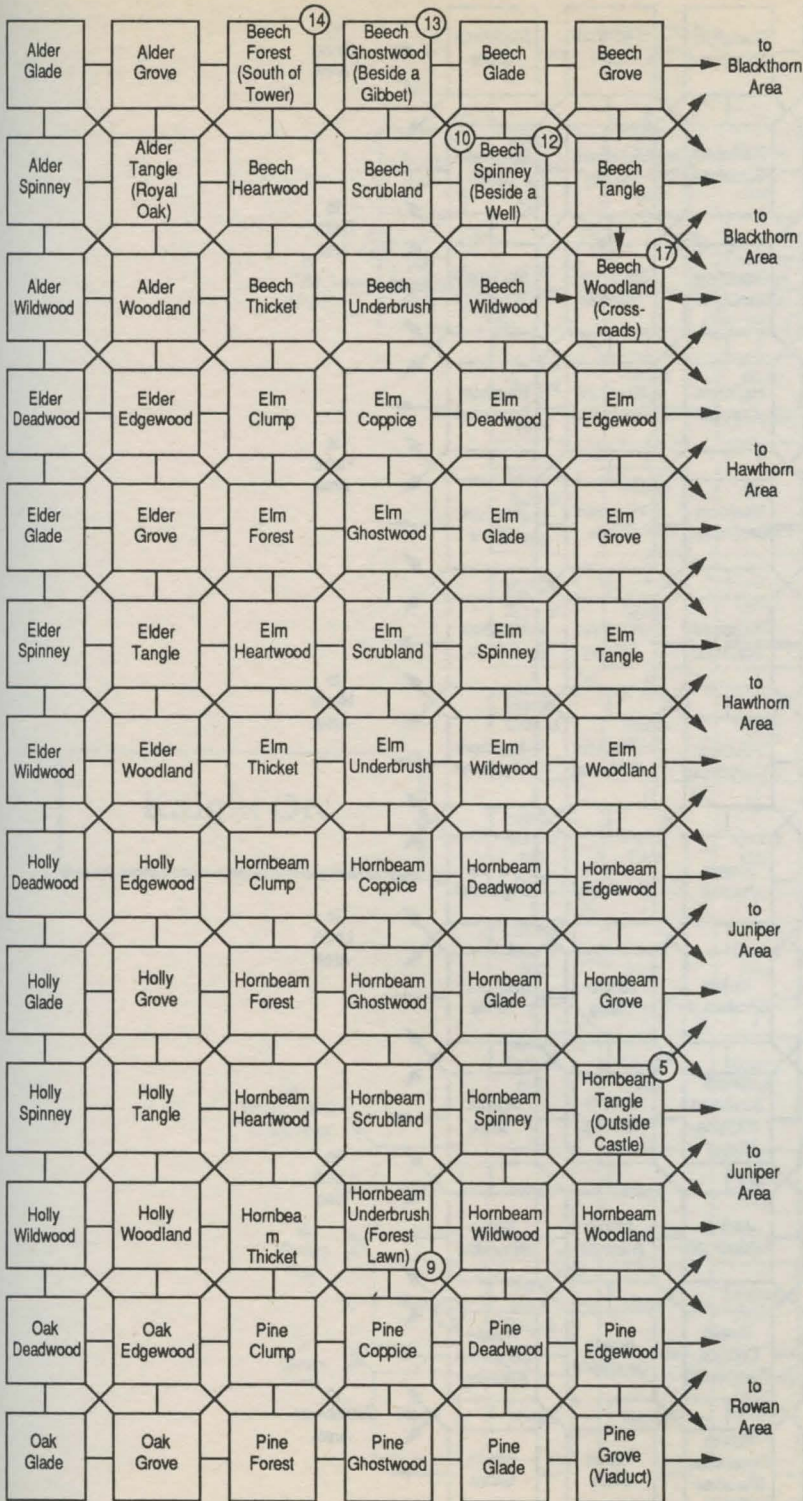

Knight Orc

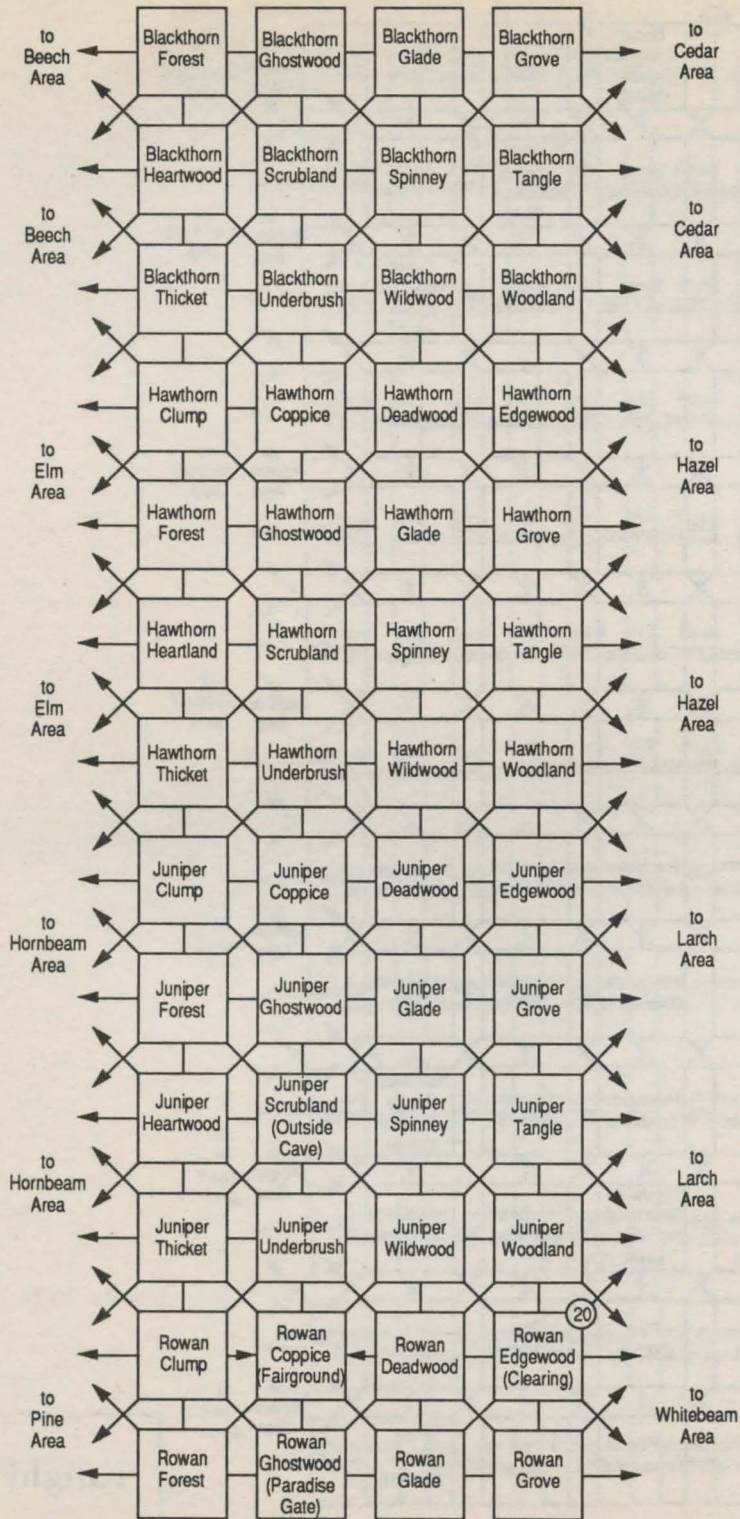

Knight Orc

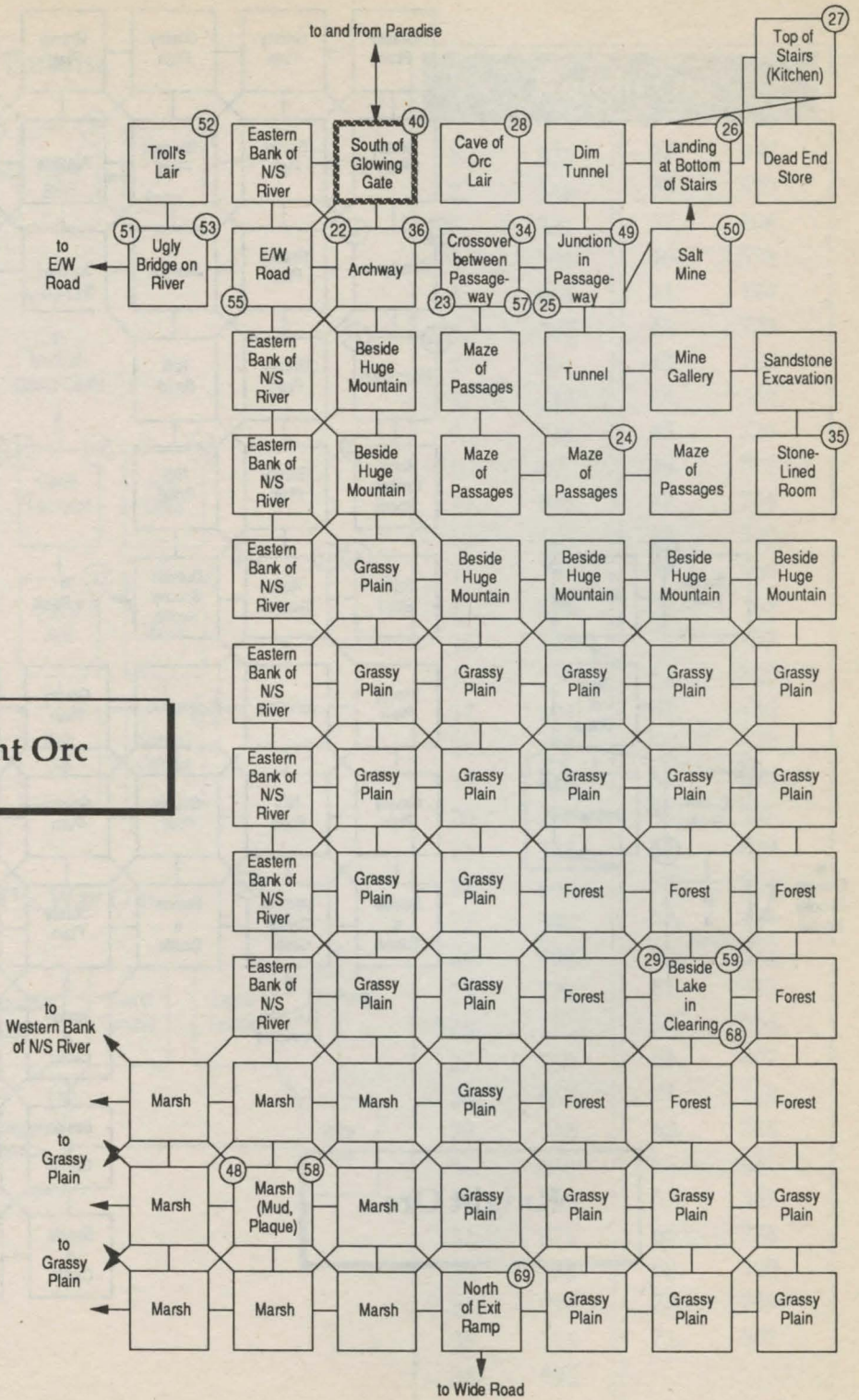

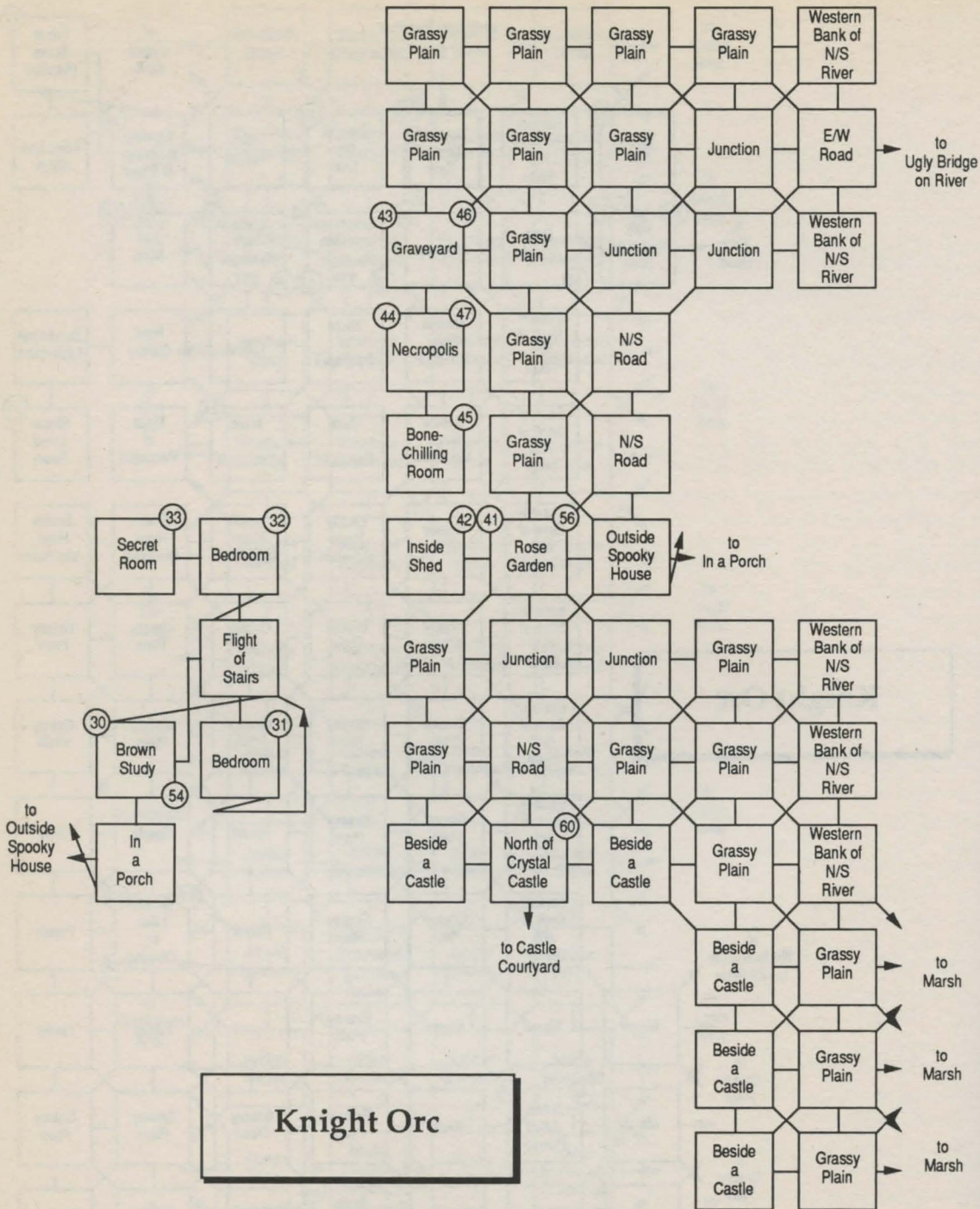

Paradise

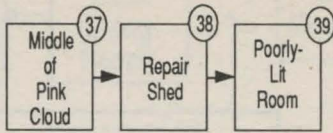

Castle

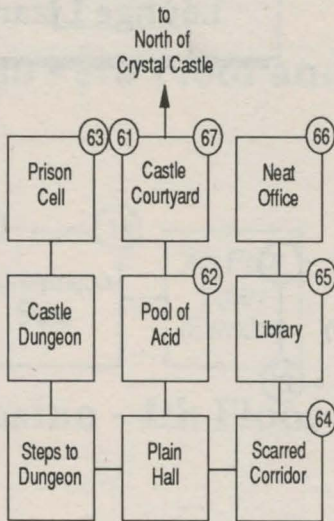

The Way Out

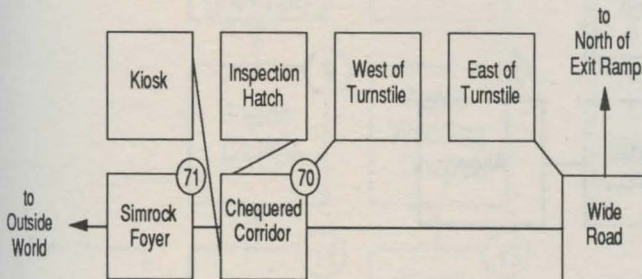

Knight Orc

1.	835	37.	297
2.	146	38.	520
3.	231	39.	106
4.	101	40.	575
5.	664	41.	184
6.	387	42.	403
7.	591	43.	765
8.	657	44.	362
9.	344	45.	226
10.	406	46.	818
11.	885	47.	254
12.	113	48.	840
13.	150	49.	656
14.	474	50.	169
15.	745	51.	752
16.	268	52.	820
17.	103	53.	440
18.	175	54.	343
19.	814	55.	512
20.	275	56.	537
21.	588	57.	809
22.	669	58.	784
23.	342	59.	424
24.	409	60.	523
25.	778	61.	312
26.	116	62.	556
27.	750	63.	497
28.	857	64.	119
29.	540	65.	545
30.	260	66.	631
31.	195	67.	582
32.	671	68.	276
33.	348	69.	190
34.	772	70.	759
35.	125	71.	903
36.	896		

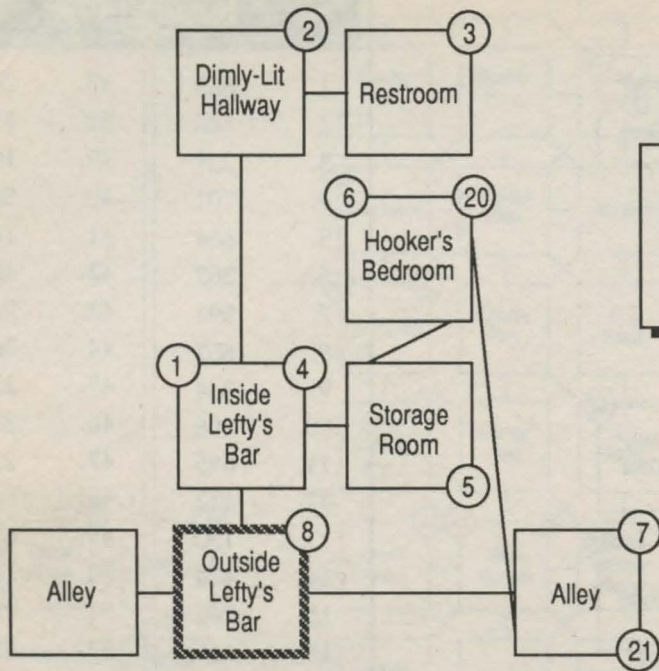

**Leisure Suit Larry:
The Land of the
Lounge Lizards**

Lefty's Bar

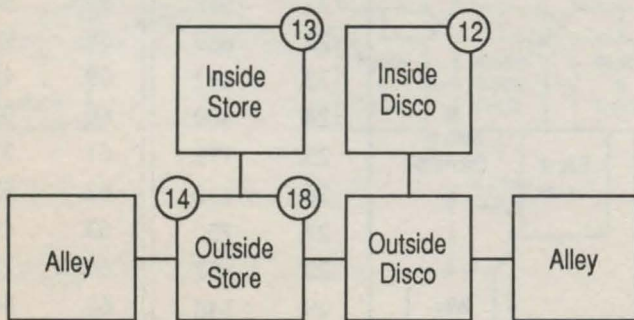

Disco

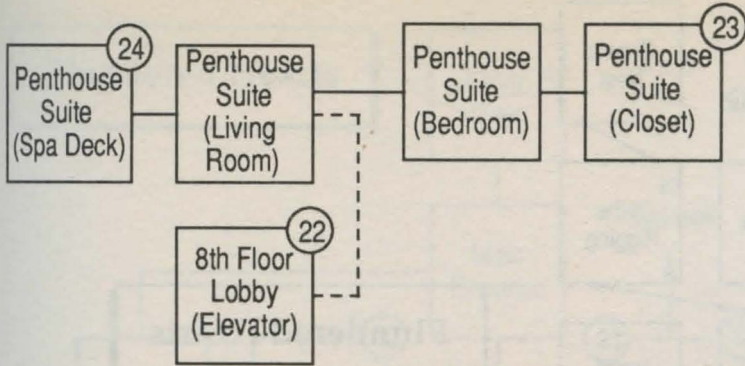

Casino - 8th Floor and Penthouse

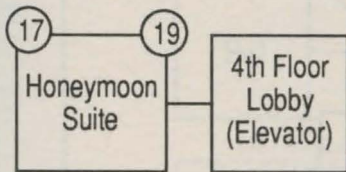

Casino - 4th Floor

Leisure Suit Larry: The Land of the Lounge Lizards			
1.	522	13.	349
2.	151	14.	217
3.	783	15.	155
4.	341	16.	284
5.	762	17.	706
6.	427	18.	756
7.	305	19.	569
8.	64	20.	395
9.	35	21.	177
10.	802	22.	704
11.	597	23.	710
12.	639	24.	562

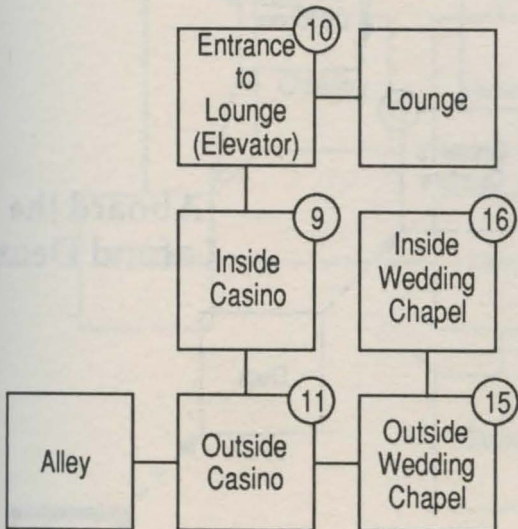

Casino

Aboard the Helena Louise

Crow's Nest

Bowsprit

In the Rigging

9 Galley

8 Fore-castle

In the Rigging

Plundered Hearts

6 Main Deck

3 Crew's Quarters

10 Quarter-deck
to Lagoon, in the Cask

4 Hold
2

Landing

Poop

Aft, Hold
7

1 Sleeping Cupboard

5 Captain's Quarters

Aboard the Lafond Deux

By the Ship, in the Skiff
to Lagoon, in the Skiff

On the Ladder

Deck

Cabin

Plundered Hearts

**Mansion
(Main Floor)**

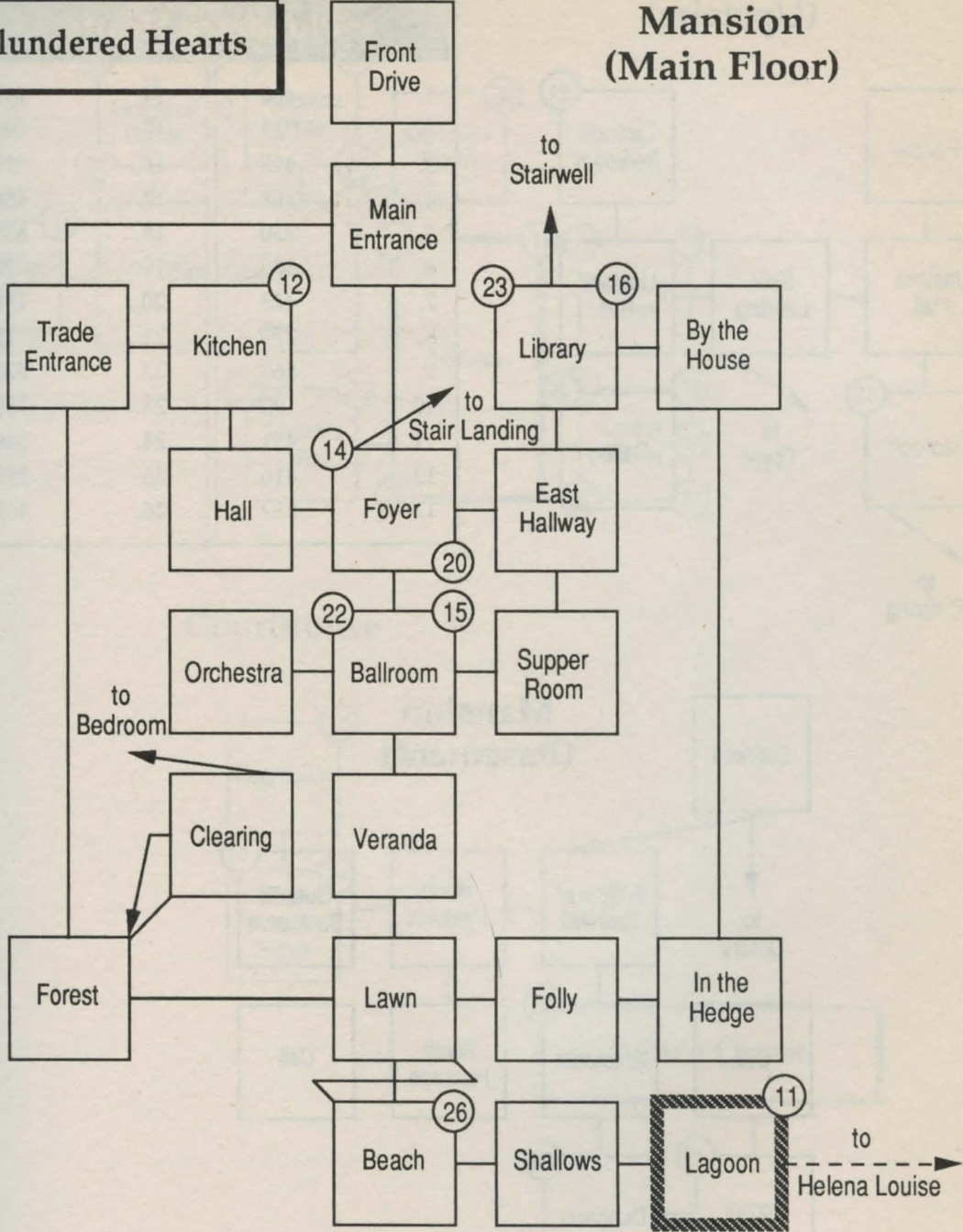

Mansion (Upstairs)

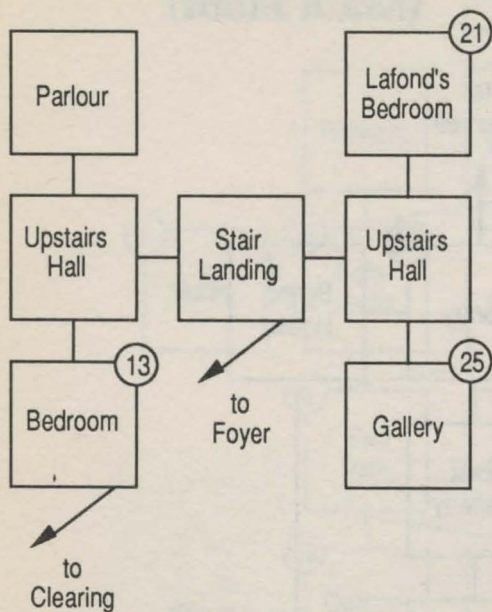

Plundered Hearts

1.	404	14.	181
2.	22	15.	494
3.	495	16.	359
4.	168	17.	480
5.	230	18.	838
6.	469	19.	839
7.	423	20.	152
8.	779	21.	13
9.	463	22.	524
10.	90	23.	739
11.	451	24.	546
12.	416	25.	253
13.	852	26.	465

Mansion (Basement)

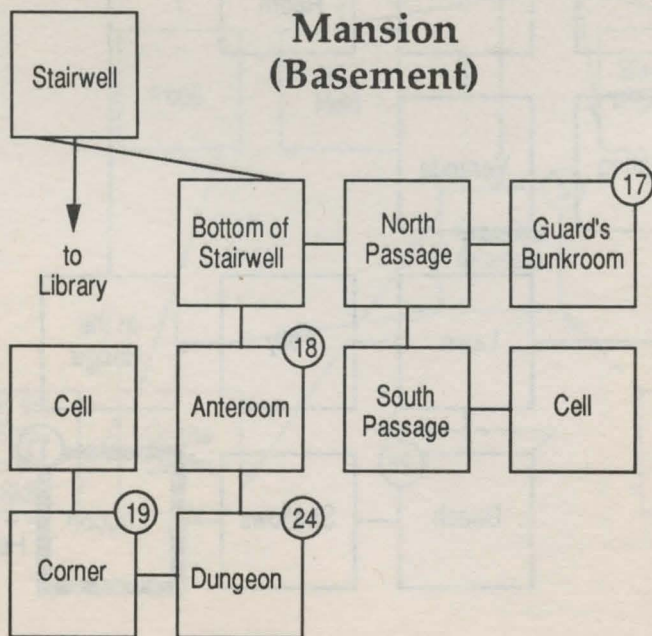

Lytton Police Department

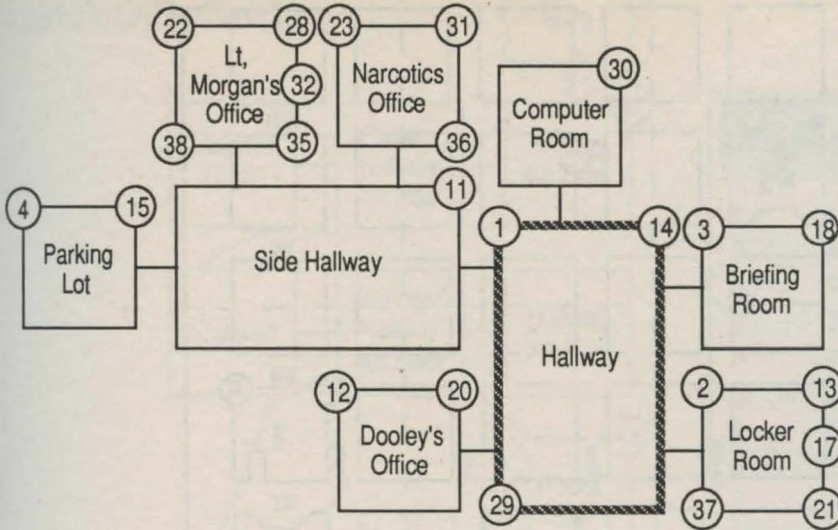

Courthouse

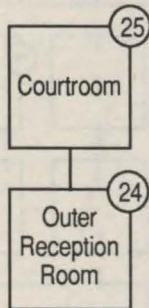

Police Quest

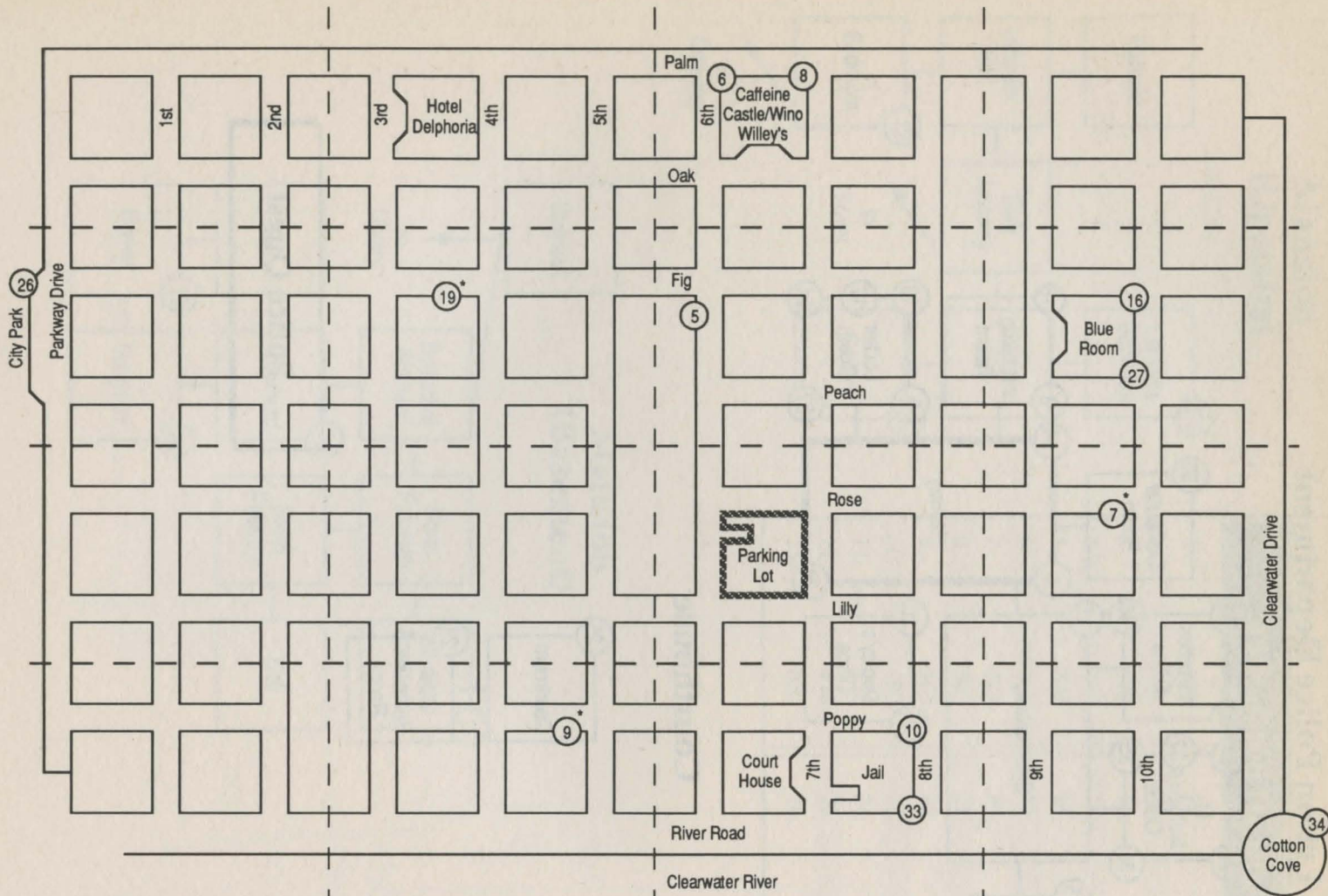

* The exact location of this clue will vary from game to game

The City

Hotel Delphoria

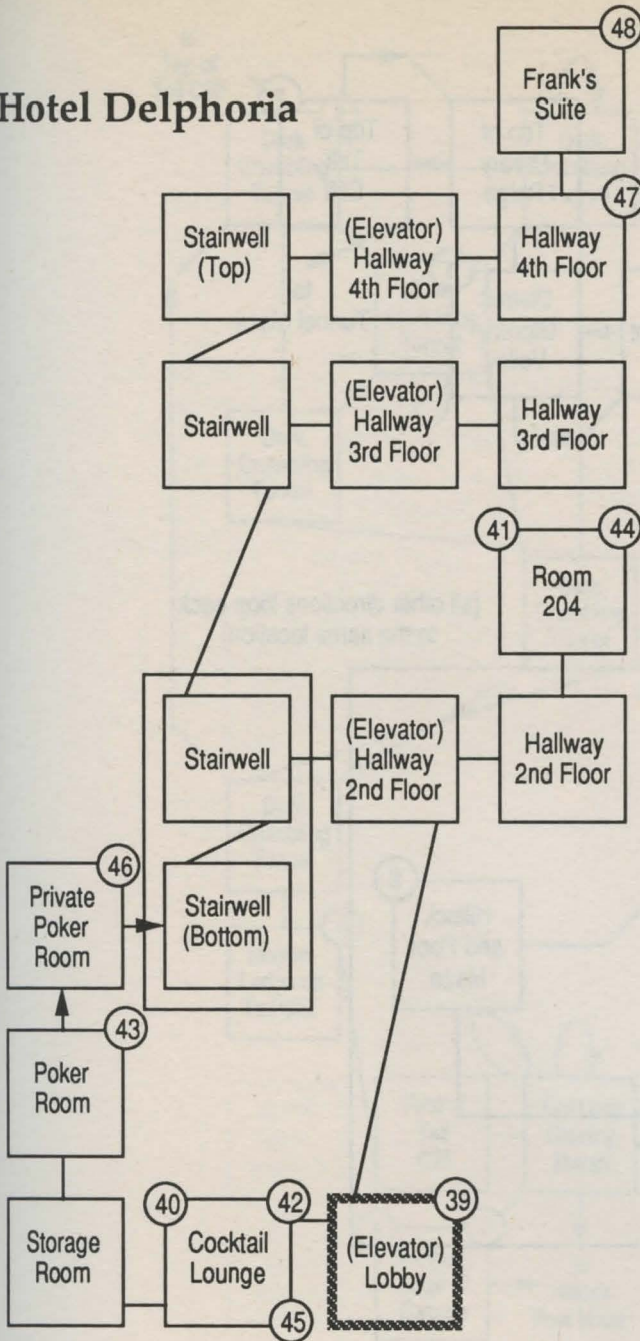

Police Quest

1.	459	25.	11
2.	421	26.	139
3.	917	27.	708
4.	208	28.	302
5.	466	29.	541
6.	23	30.	563
7.	572	31.	38
8.	273	32.	292
9.	462	33.	687
10.	89	34.	616
11.	390	35.	555
12.	822	36.	163
13.	801	37.	898
14.	240	38.	140
15.	70	39.	83
16.	80	40.	399
17.	692	41.	185
18.	748	42.	148
19.	640	43.	31
20.	521	44.	899
21.	74	45.	173
22.	381	46.	761
23.	377	47.	741
24.	198	48.	364

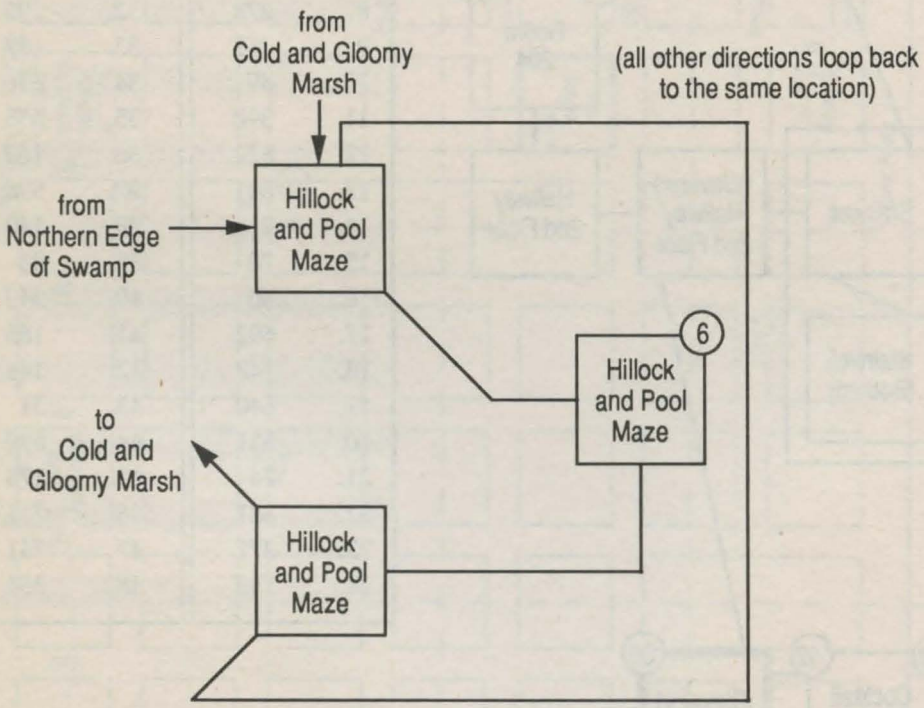
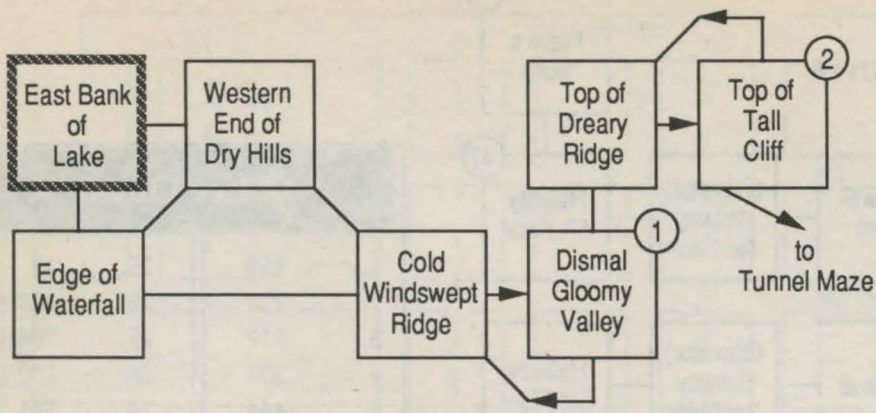

Shadows of Mordor

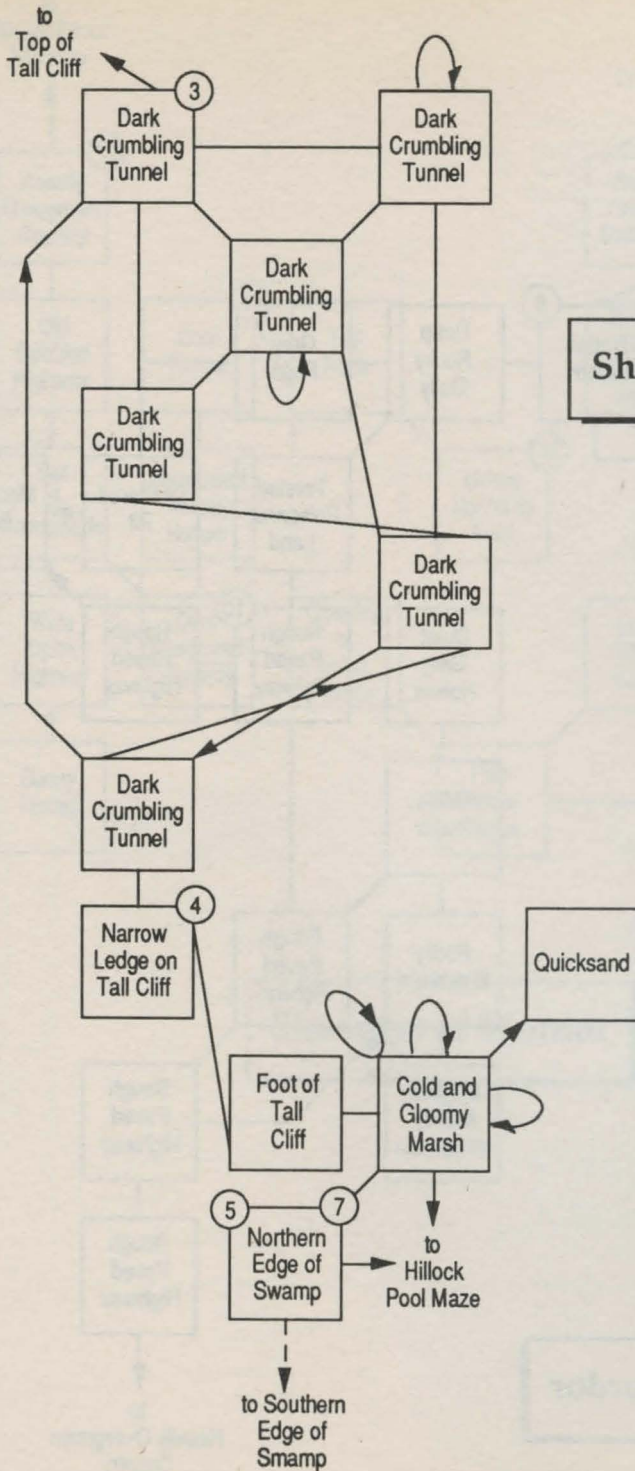

Shadows of Mordor

to
Northern Edge
of Swamp

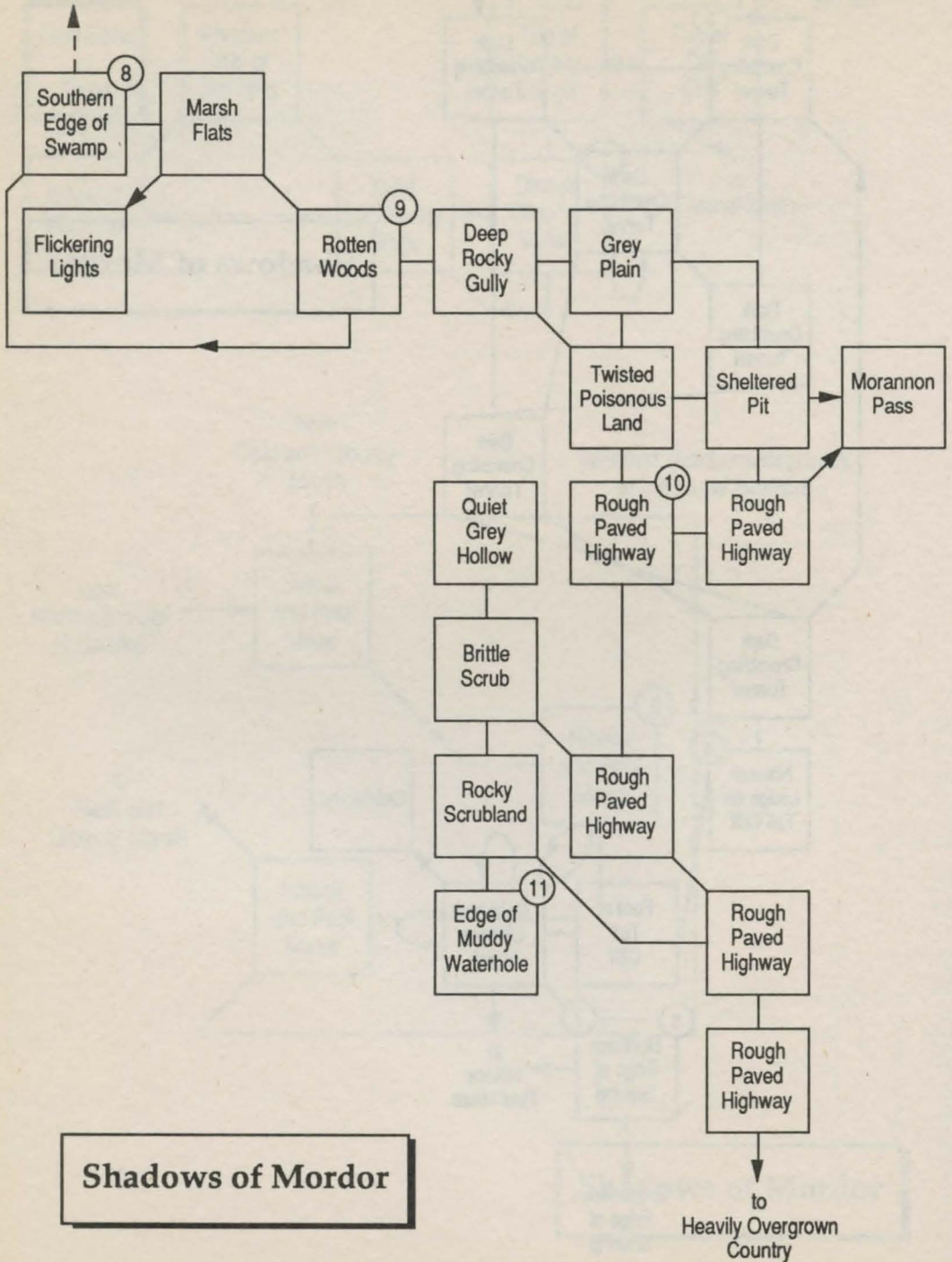

Shadows of Mordor

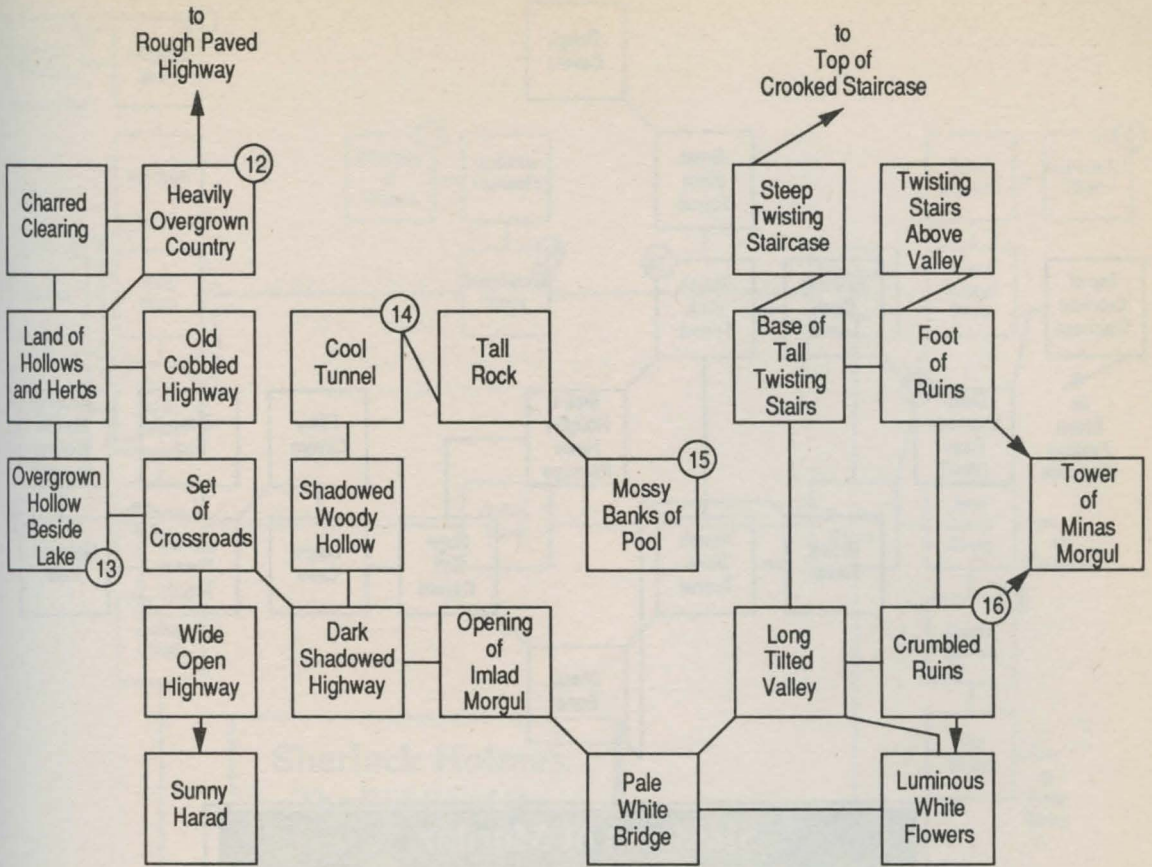

Shadows of Mordor

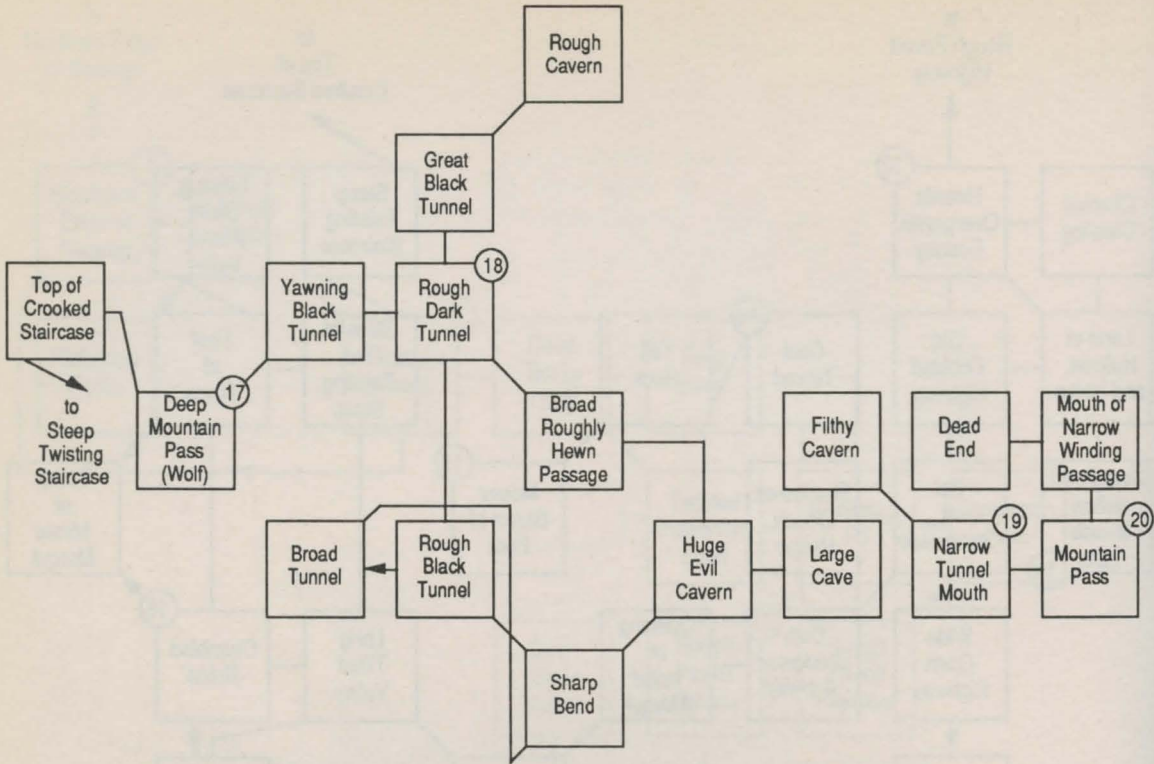

Shadows of Mordor			
1.	812	11.	388
2.	876	12.	921
3.	530	13.	71
4.	553	14.	136
5.	881	15.	318
6.	234	16.	804
7.	122	17.	154
8.	499	18.	267
9.	912	19.	472
10.	356	20.	827

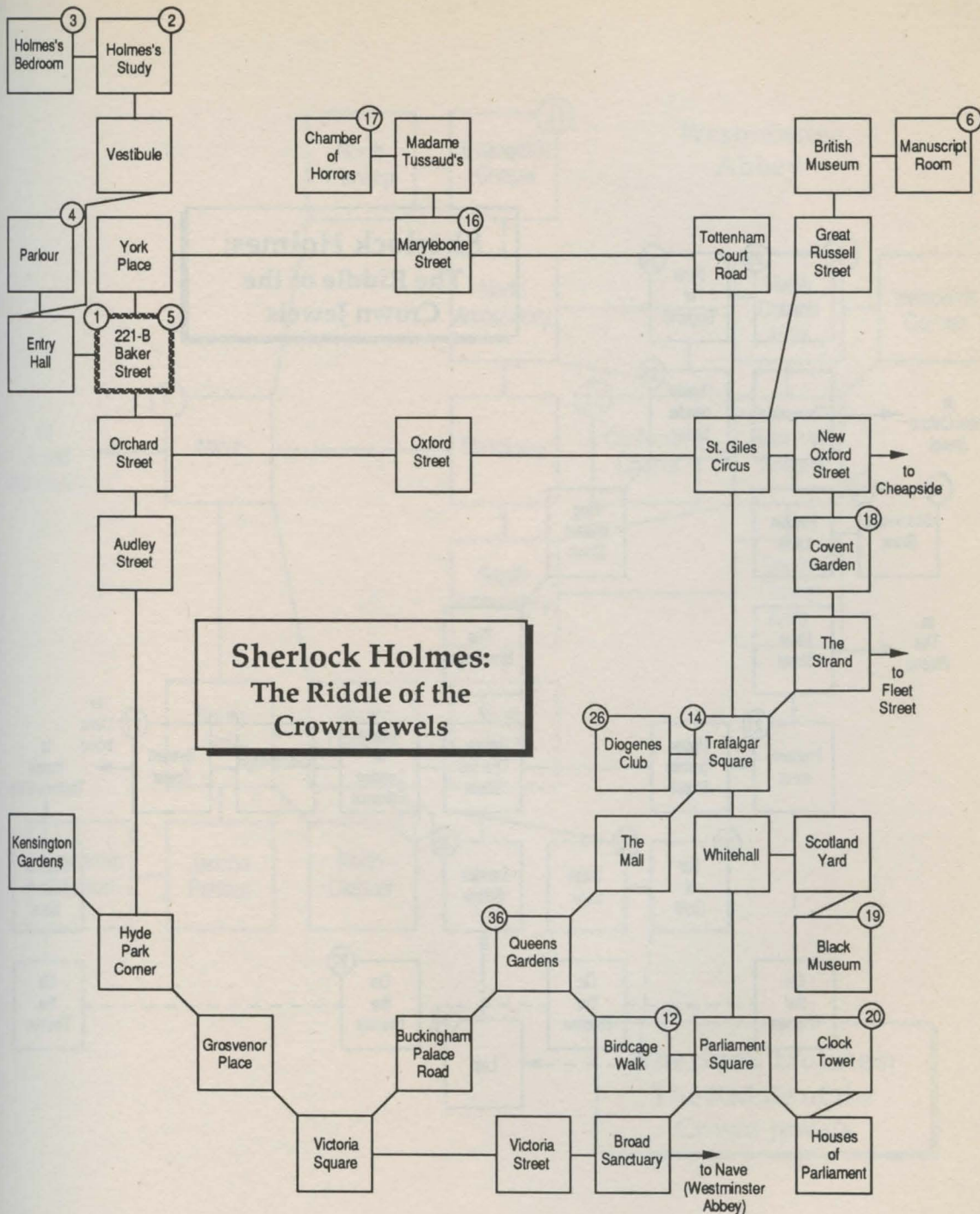

Sherlock Holmes: The Riddle of the Crown Jewels

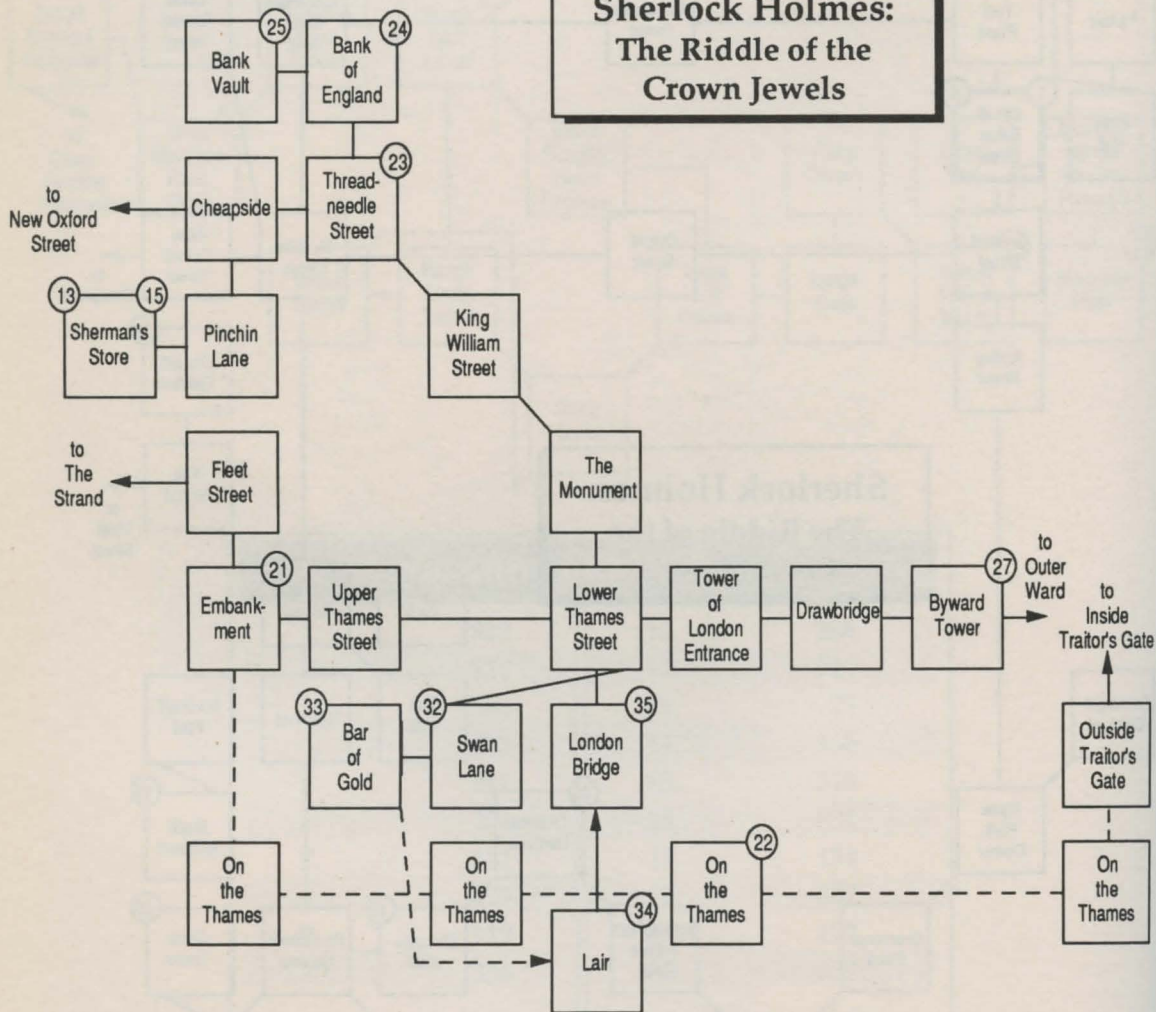

Westminster Abbey

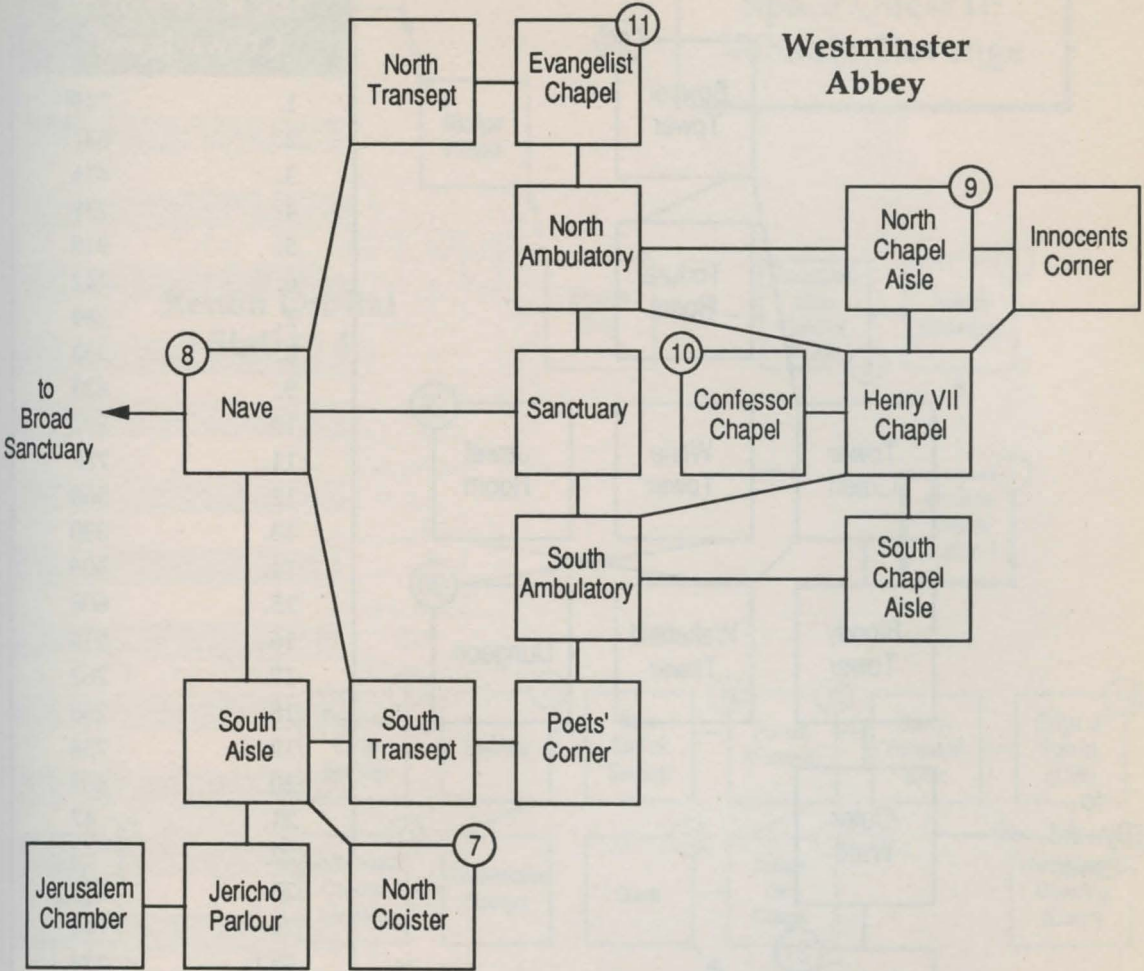

**Sherlock Holmes:
The Riddle of the
Crown Jewels**

Tower of London

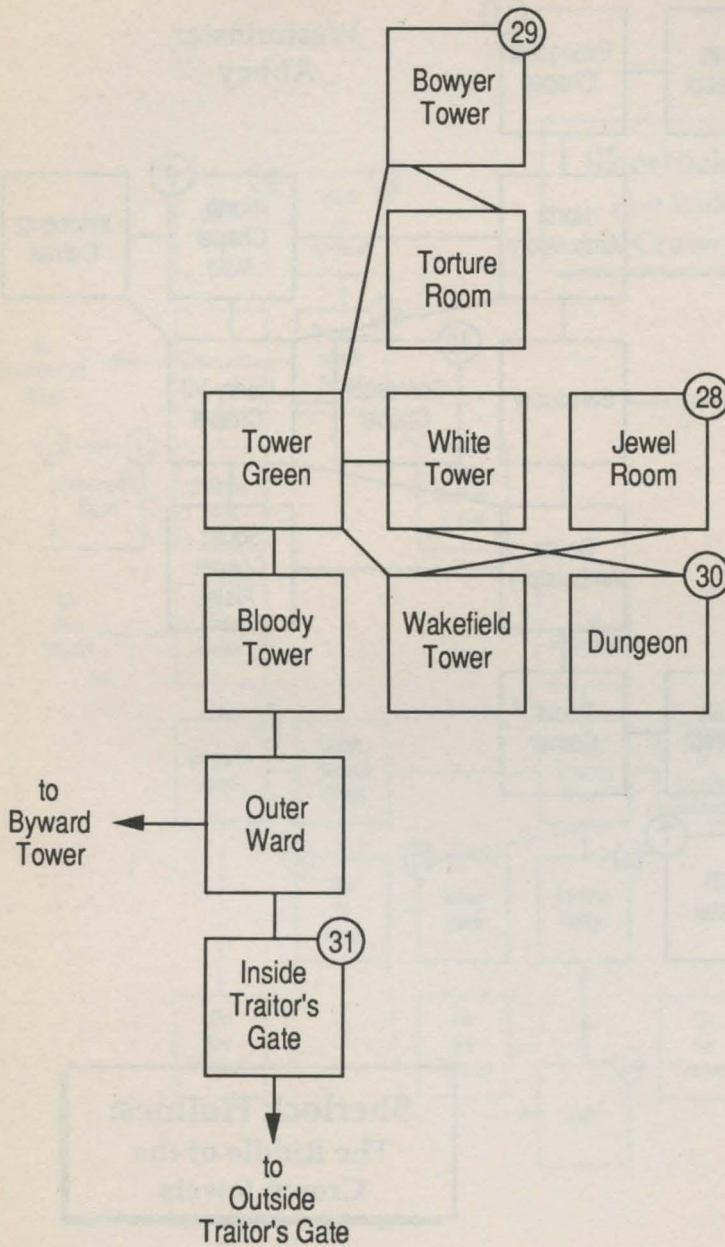

Sherlock Holmes: The Riddle of the Crown Jewels

1.	245
2.	637
3.	414
4.	239
5.	910
6.	442
7.	289
8.	352
9.	623
10.	332
11.	787
12.	568
13.	330
14.	306
15.	608
16.	516
17.	262
18.	236
19.	734
20.	889
21.	47
22.	62
23.	408
24.	740
25.	124
26.	77
27.	271
28.	127
29.	485
30.	886
31.	27
32.	272
33.	650
34.	489
35.	86
36.	250

Space Quest II: Vohaul's Revenge

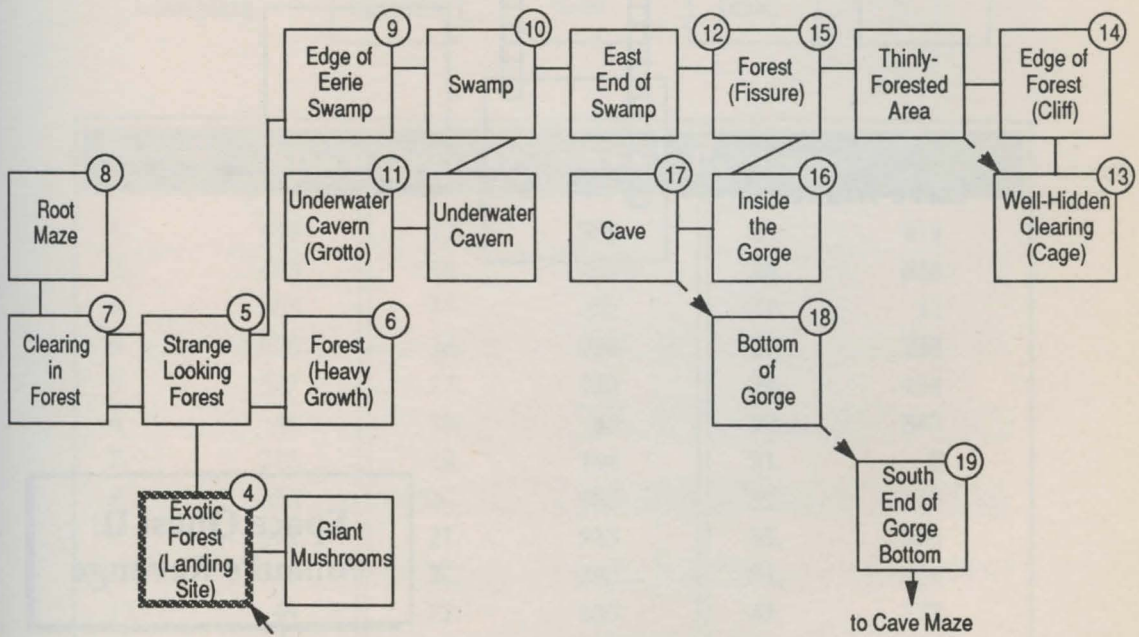
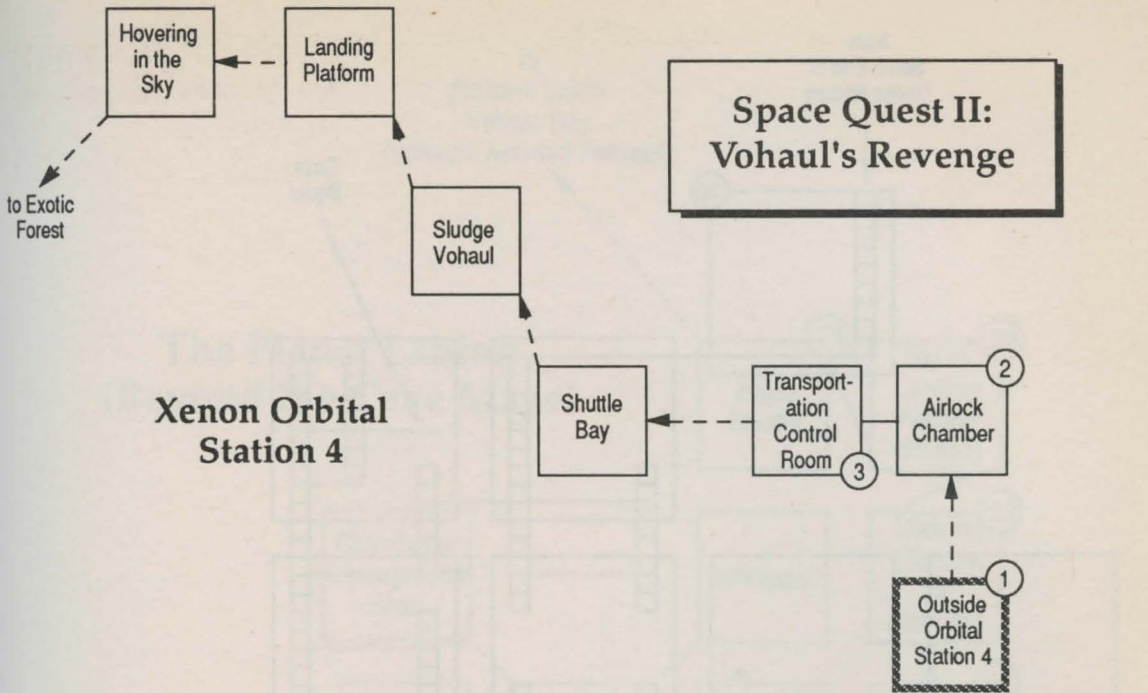

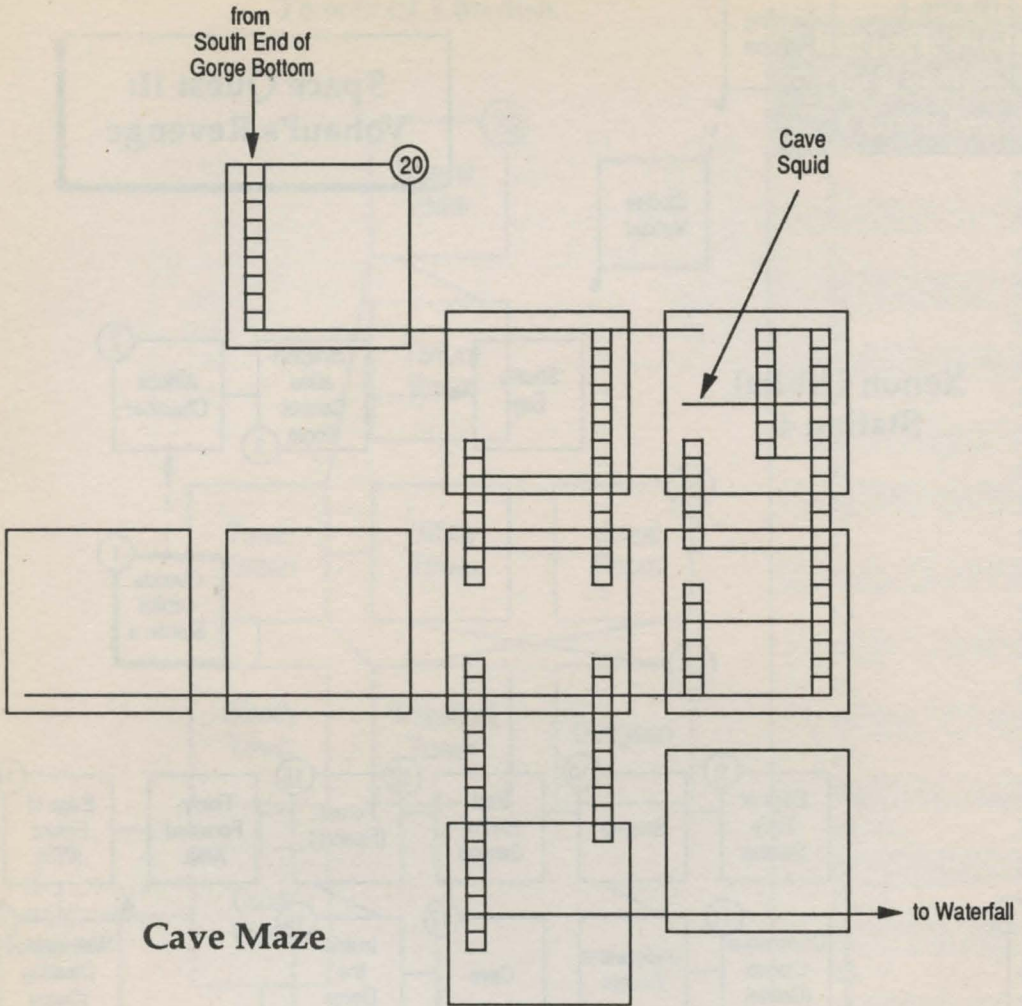

Cave Maze

**Space Quest II:
Vohaul's Revenge**

The Planet Labion (Beyond the Cave Maze)

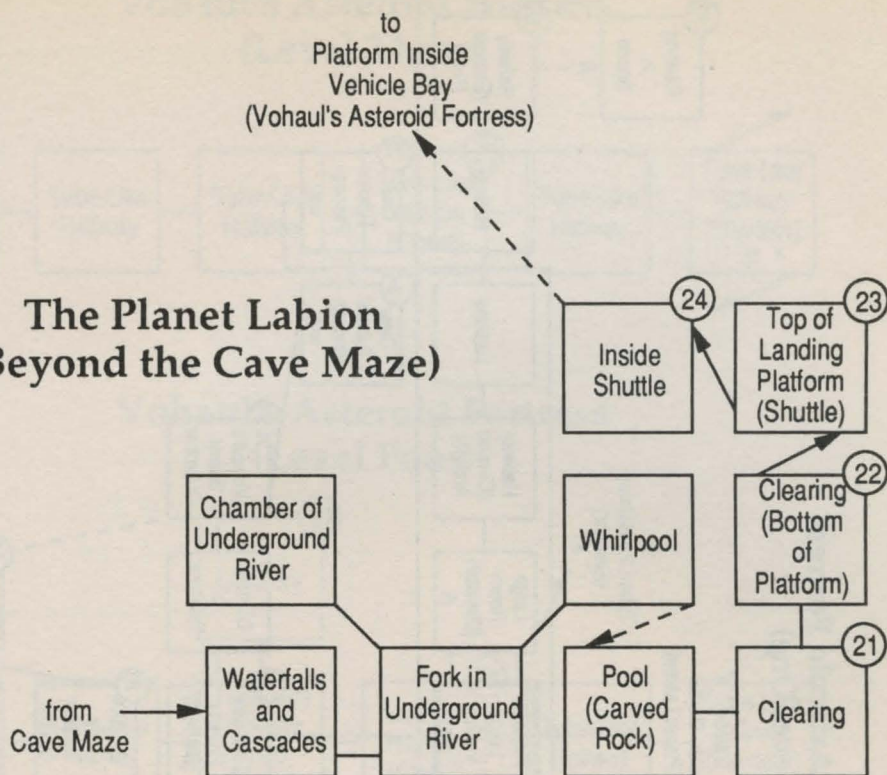

Space Quest II: Vohaul's Revenge

1.	418	13.	805	25.	919
2.	435	14.	486	26.	626
3.	605	15.	357	27.	12
4.	576	16.	764	28.	258
5.	577	17.	920	29.	434
6.	48	18.	46	30.	842
7.	215	19.	194	31.	7
8.	653	20.	658	32.	75
9.	698	21.	913	33.	286
10.	712	22.	780	34.	354
11.	44	23.	830	35.	578
12.	315	24.	443	36.	380
				37.	322

Vohaul's Asteroid Fortress (Level One)

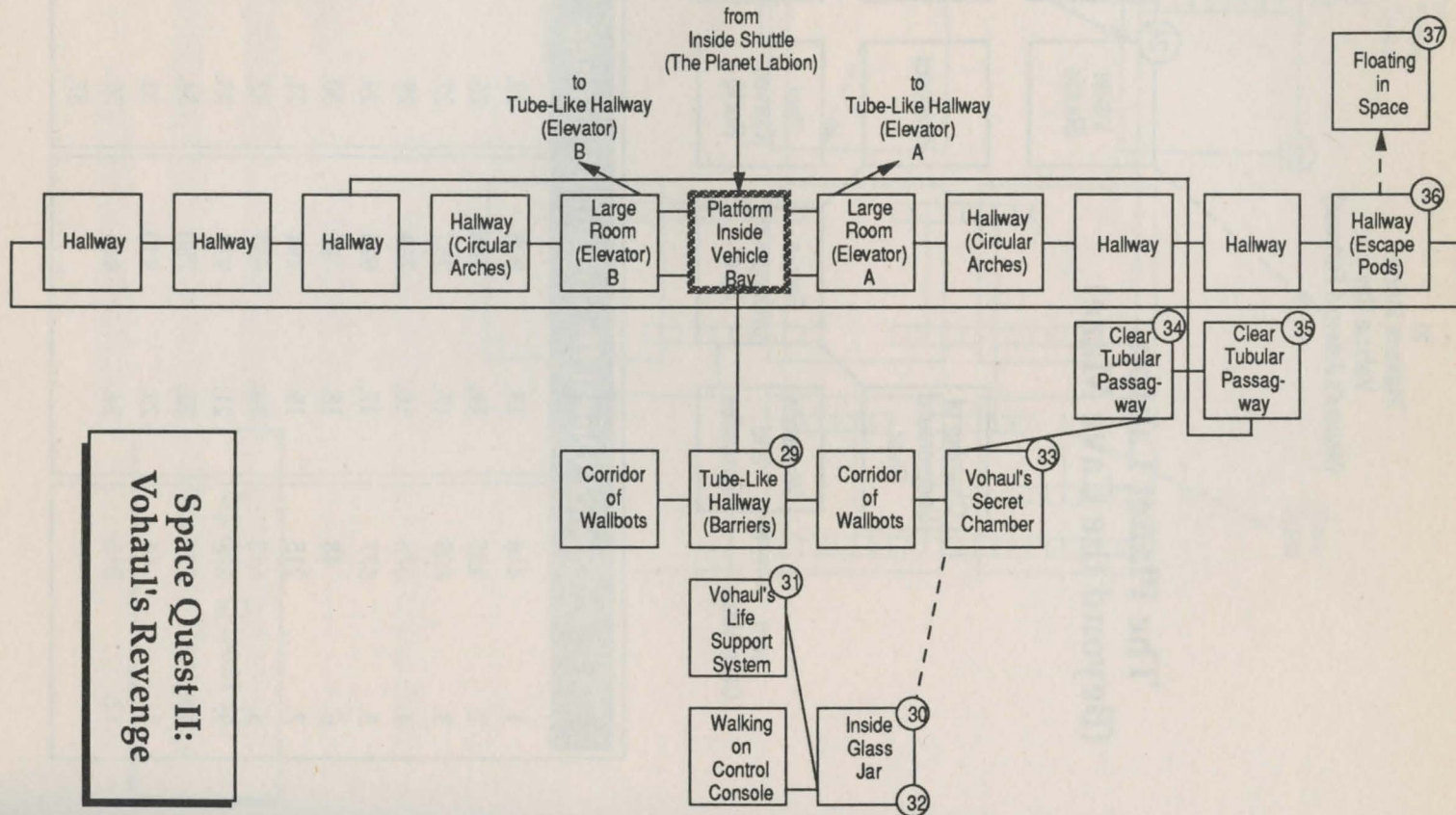

Vohaul's Asteroid Fortress (Level Three)

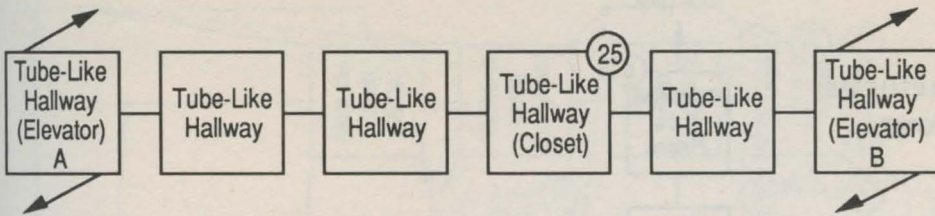

Vohaul's Asteroid Fortress (Level Four)

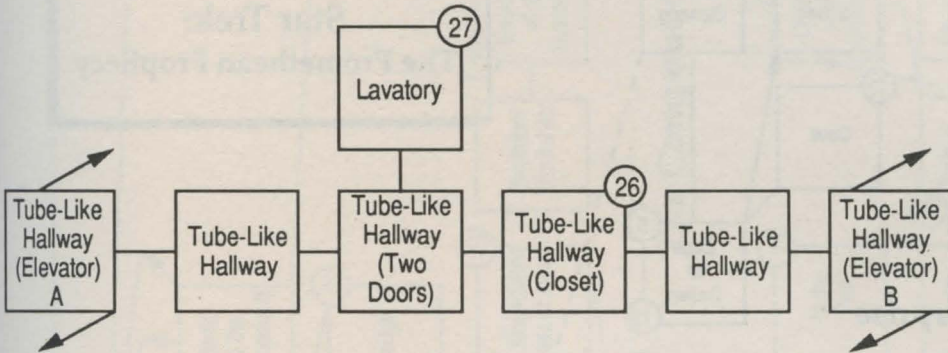

Vohaul's Asteroid Fortress (Level Five)

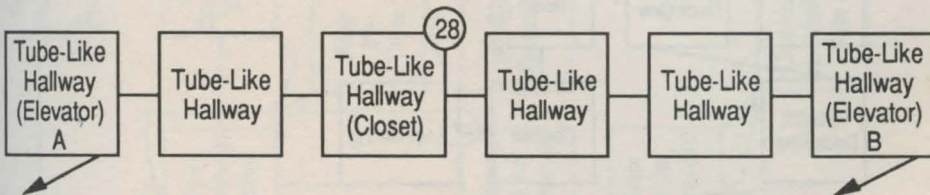

**Space Quest II:
Vohaul's Revenge**

**Prometheus
Four**

to Before the
Blue Gate

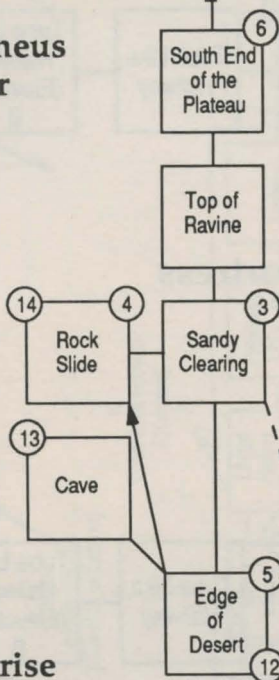

**Star Trek:
The Promethean Prophecy**

Enterprise

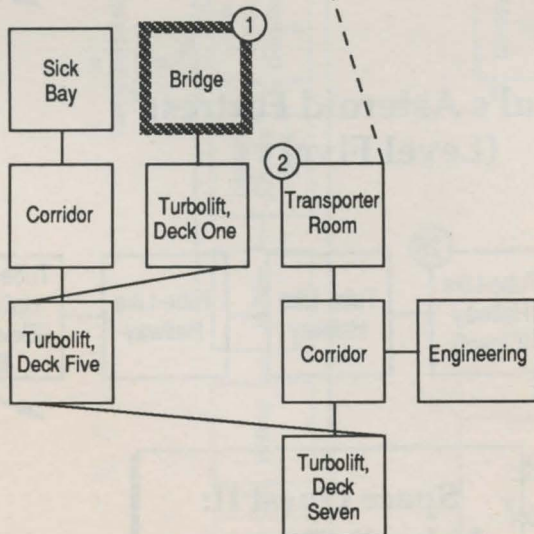

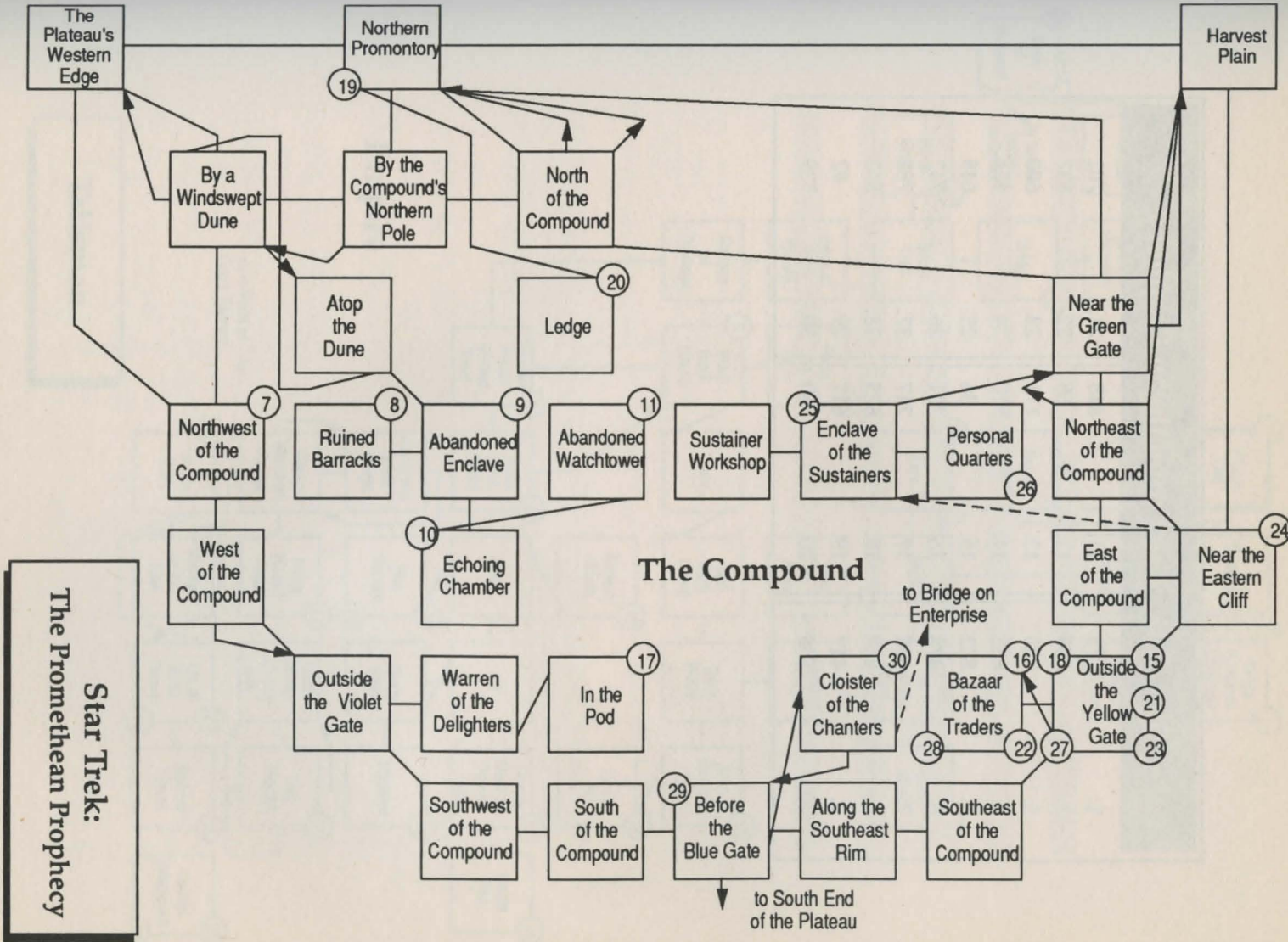

Star Trek:
The Promethean Prophecy

The Compound

to South End of the Plateau

to Bridge on Enterprise

Star Trek: The Promethean Prophecy

1.	73	11.	848	21.	702
2.	339	12.	65	22.	837
3.	735	13.	171	23.	600
4.	685	14.	810	24.	454
5.	882	15.	36	25.	648
6.	478	16.	701	26.	747
7.	458	17.	247	27.	782
8.	908	18.	625	28.	862
9.	417	19.	611	29.	42
10.	558	20.	360	30.	539

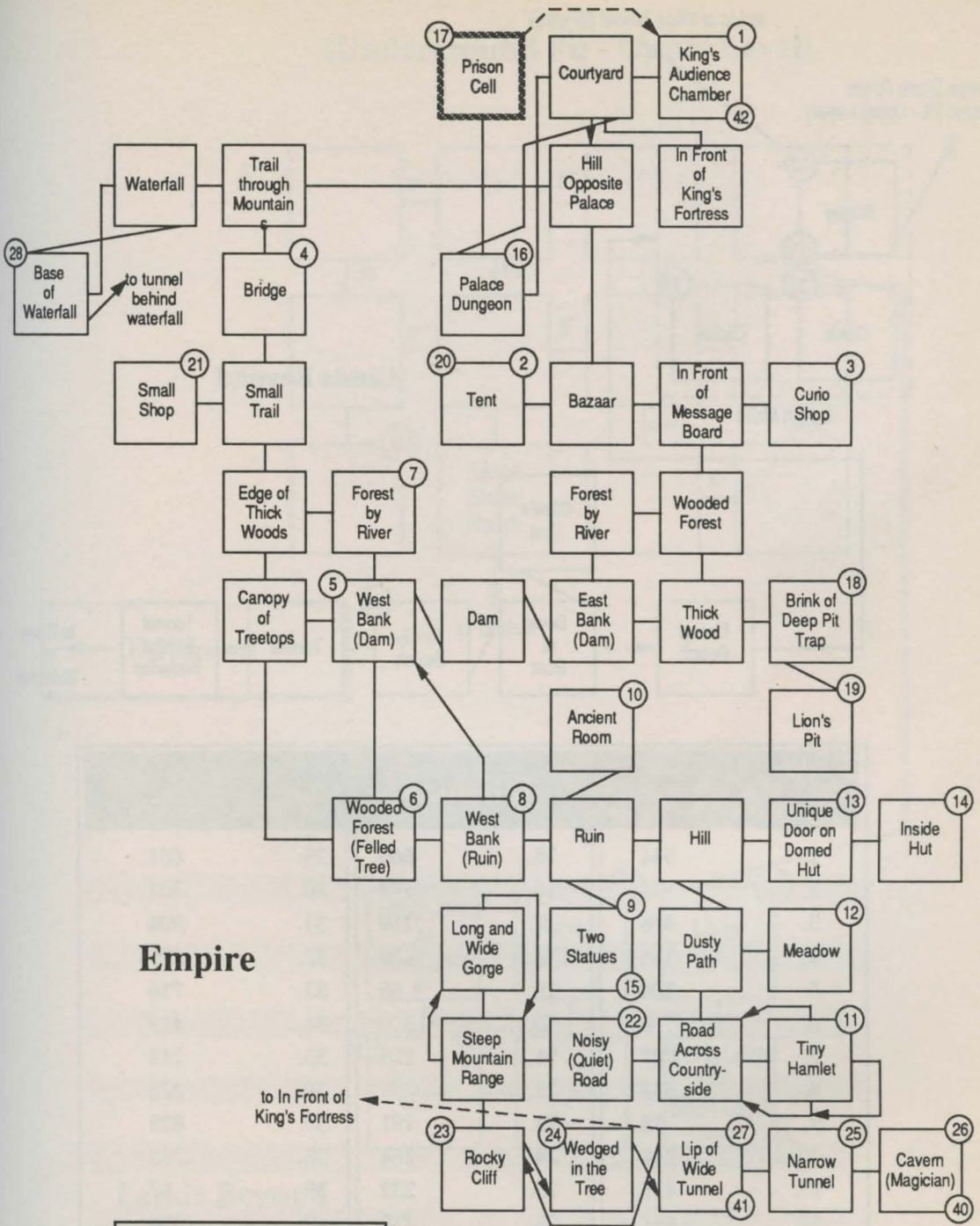

Empire

Talisman

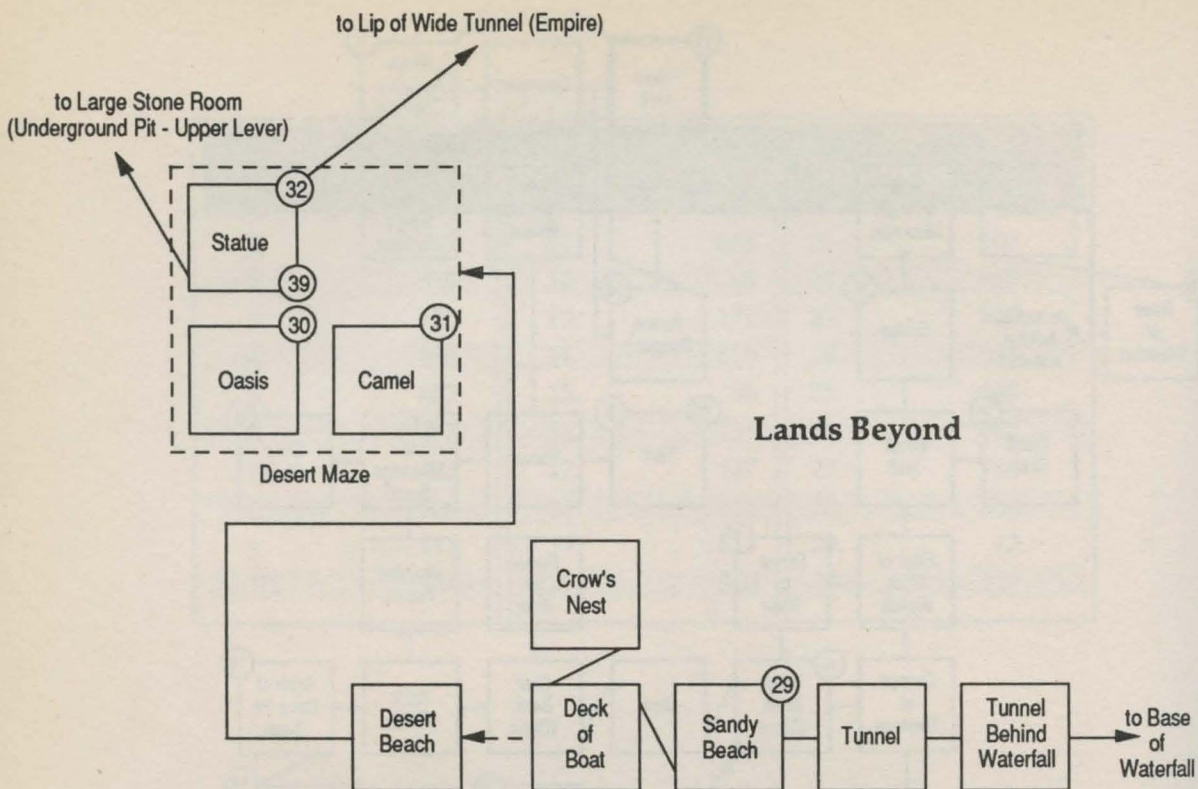

Talisman			
1.	544	15.	660
2.	594	16.	199
3.	476	17.	159
4.	156	18.	50
5.	104	19.	66
6.	9	20.	310
7.	737	21.	225
8.	612	22.	753
9.	28	23.	191
10.	244	24.	264
11.	479	25.	252
12.	684	26.	719
13.	703	27.	566
14.	294	28.	266
		29.	681
		30.	301
		31.	904
		32.	279
		33.	716
		34.	429
		35.	213
		36.	328
		37.	828
		38.	785
		39.	67
		40.	304
		41.	320
		42.	228

(Underground Pit - Upper Level)

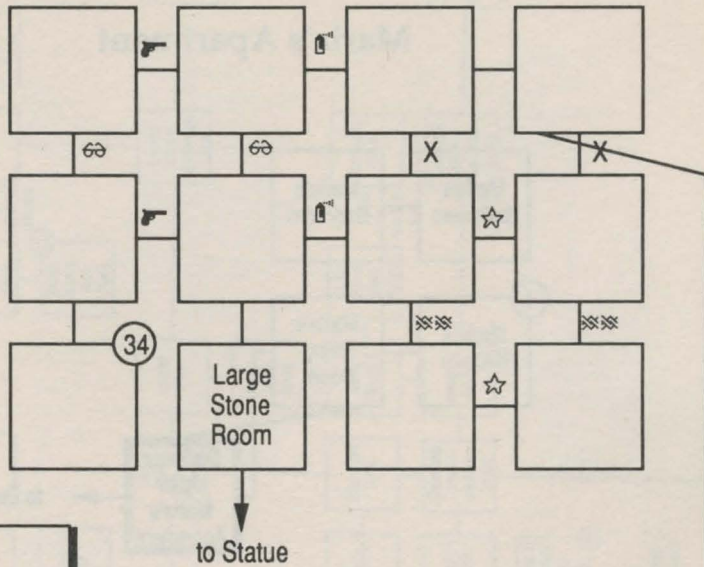

Talisman

(Underground Pit - Lower Level)

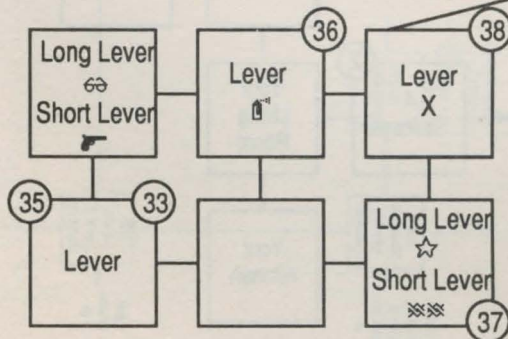

Lands Beyond

The levers indicated by a particular symbol control (open/close) the walls on the upper level indicated by the same symbol

Maria's Apartment

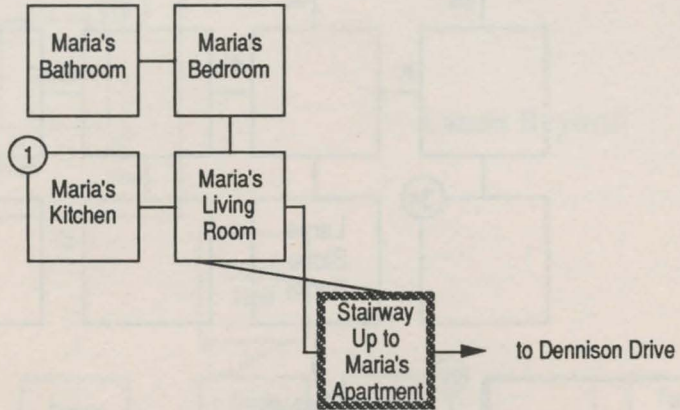

Your Apartment

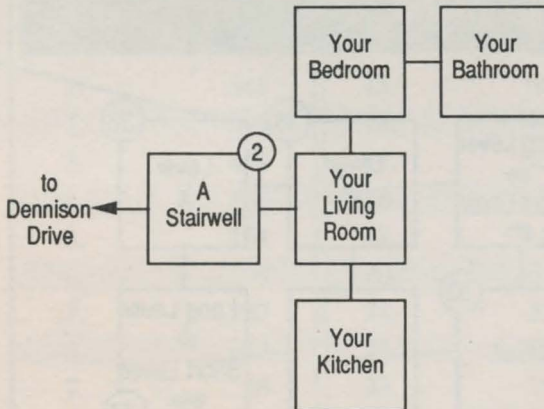

Twilight's Ransom

Twilight's Ransom

Shadeside

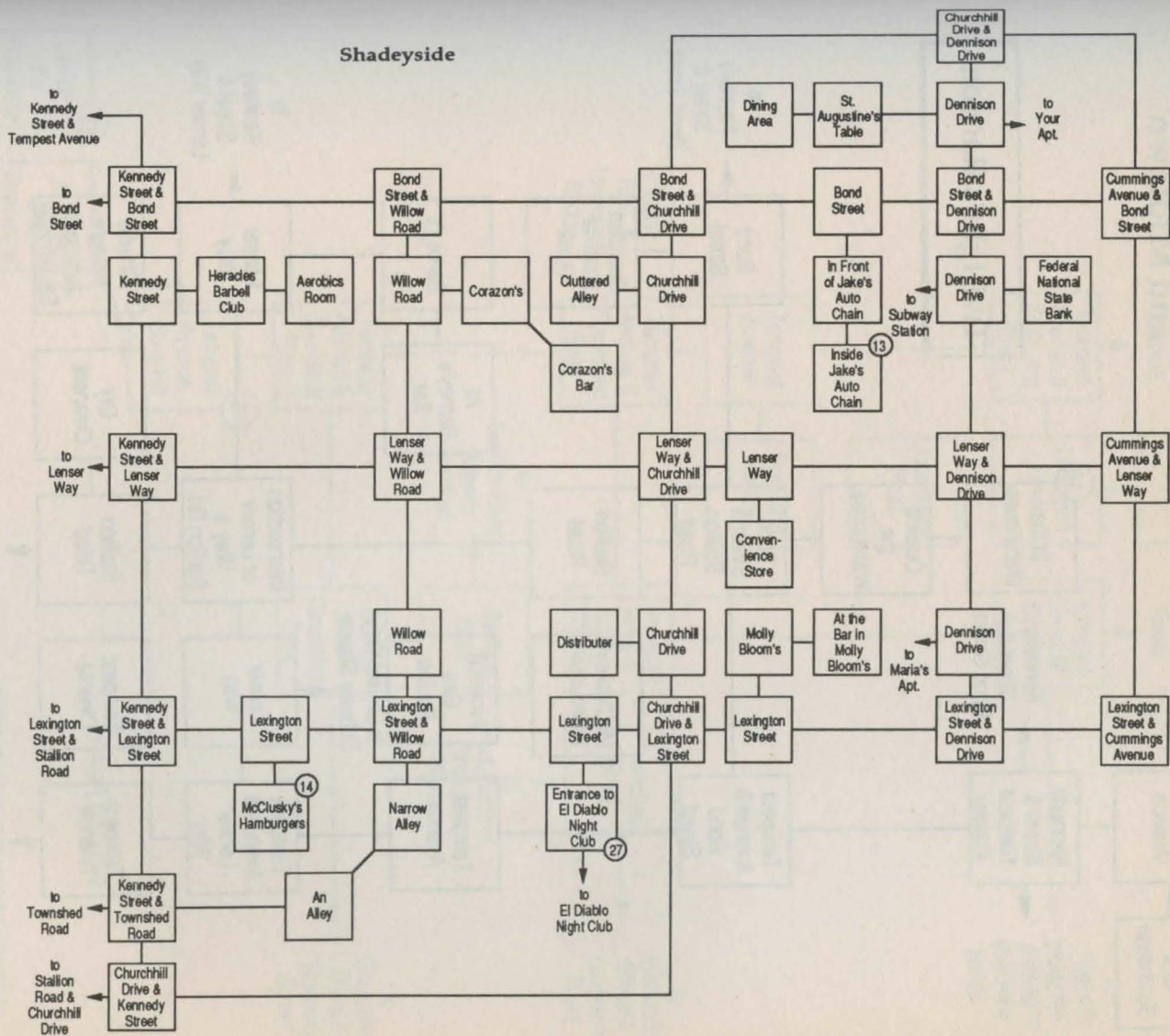

Upper Eastside and Midtown

Twilight's Ransom

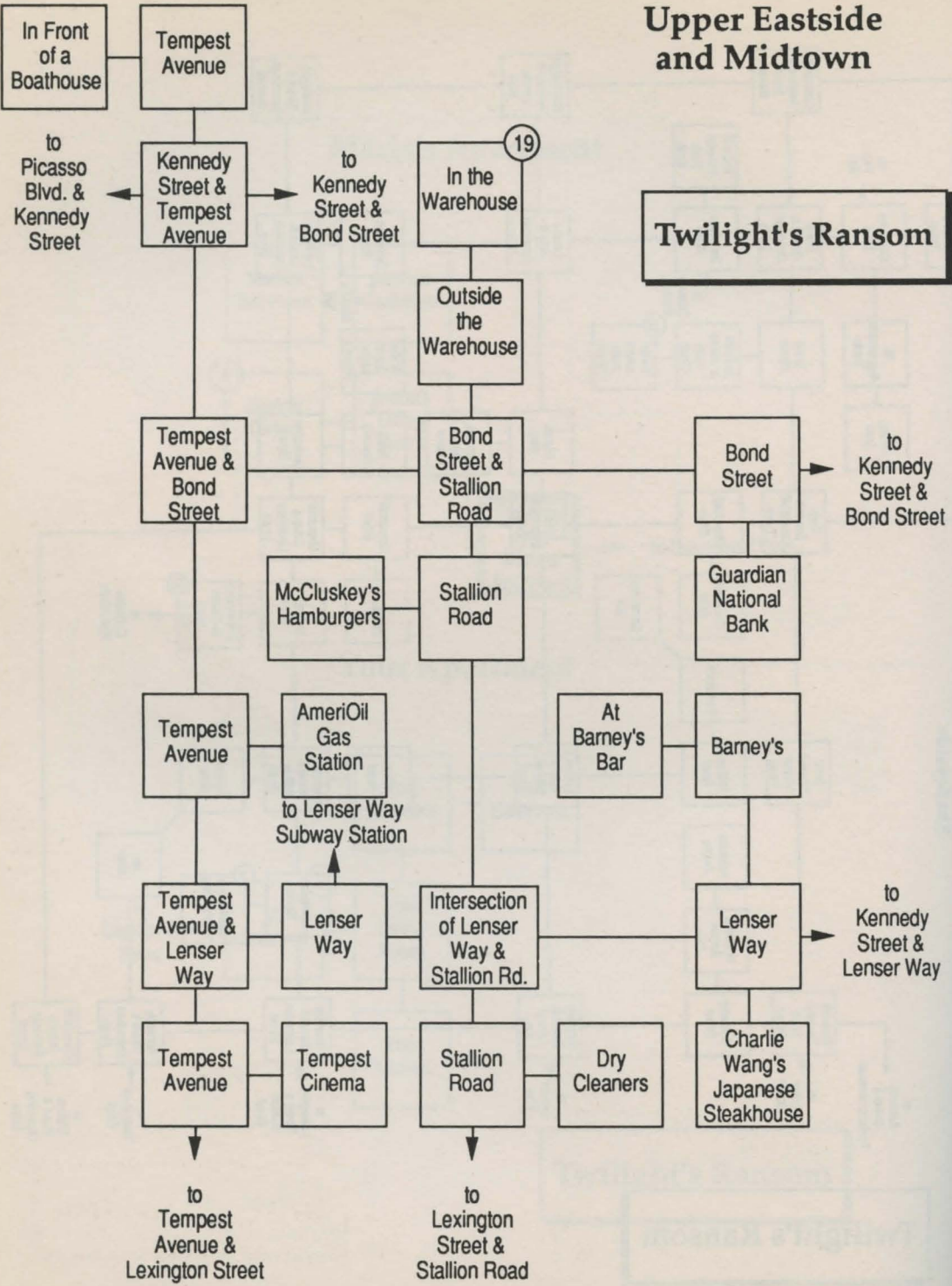

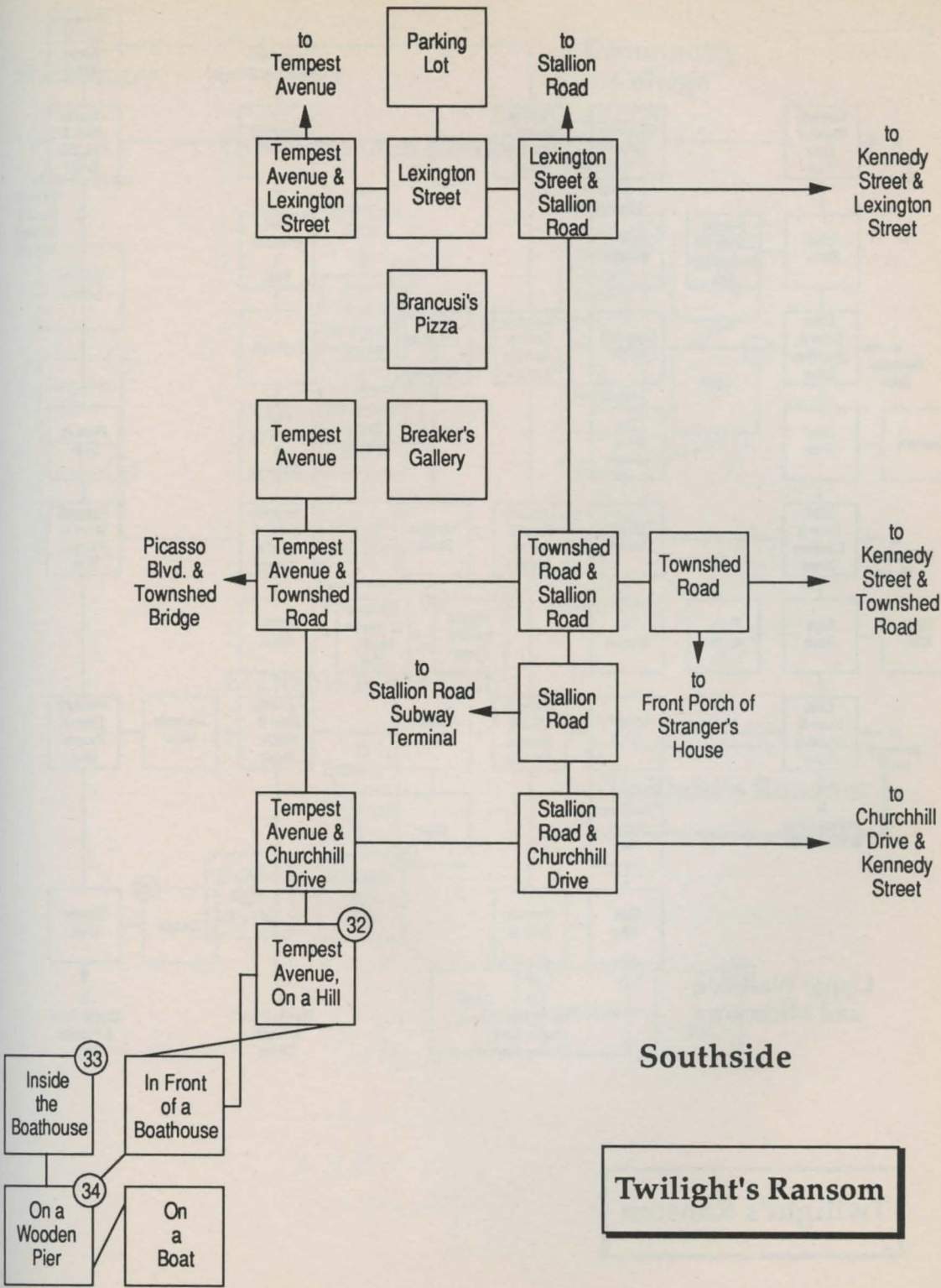

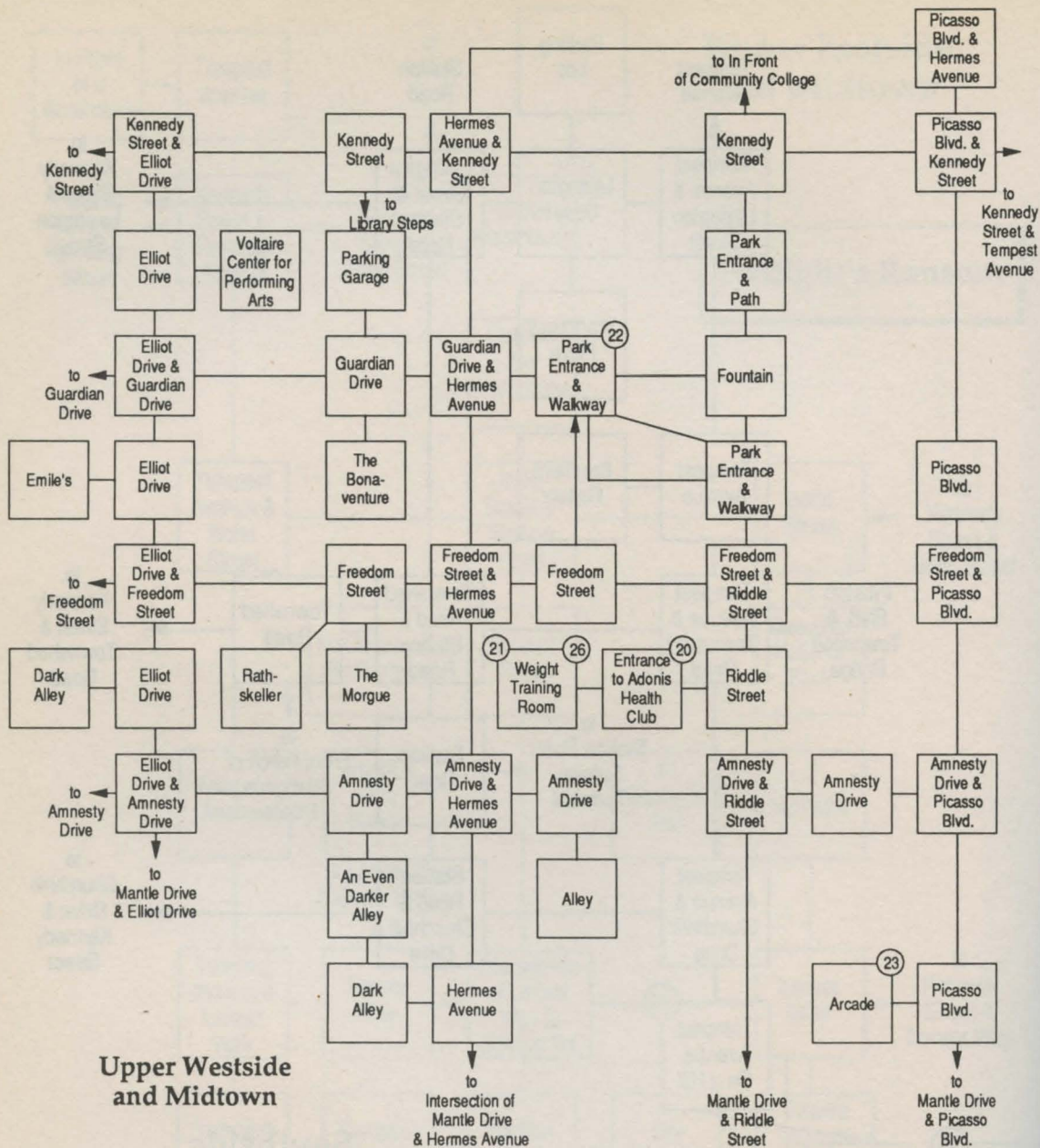

**Upper Westside
and Midtown**

Twilight's Ransom

The Library

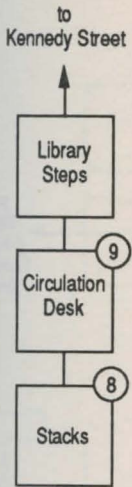

The Clenondon House

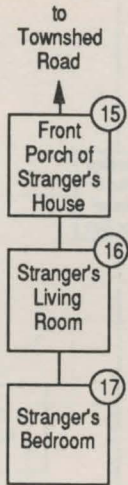

Community College

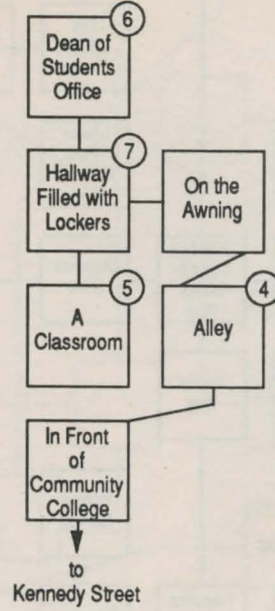

El Diablo Night Club

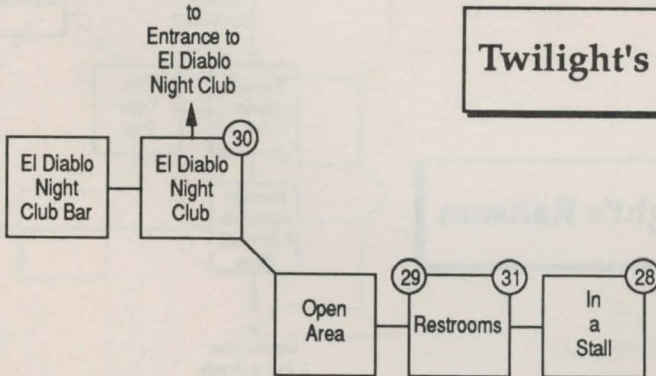

Twilight's Ransom

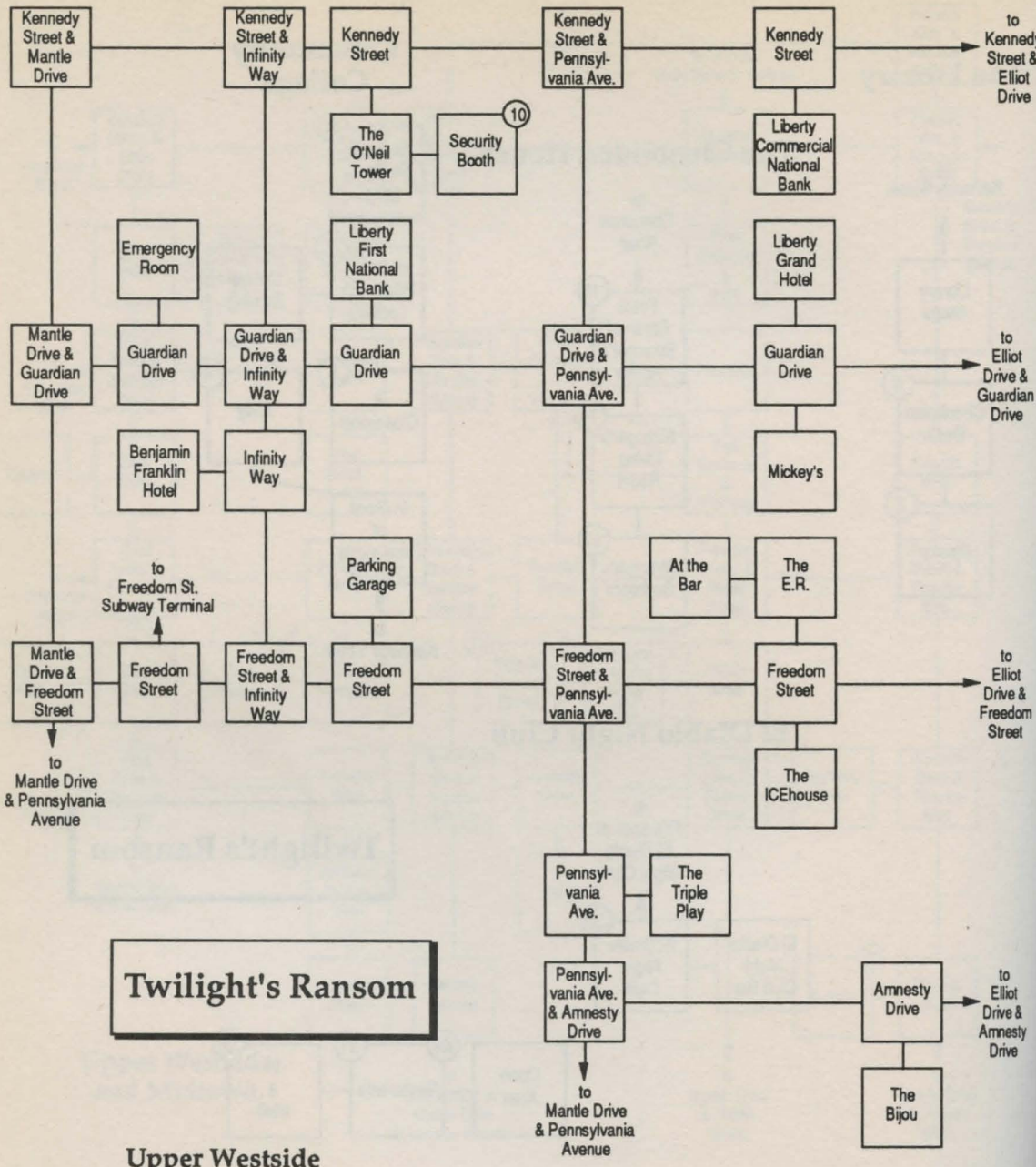

Twilight's Ransom

Upper Westside

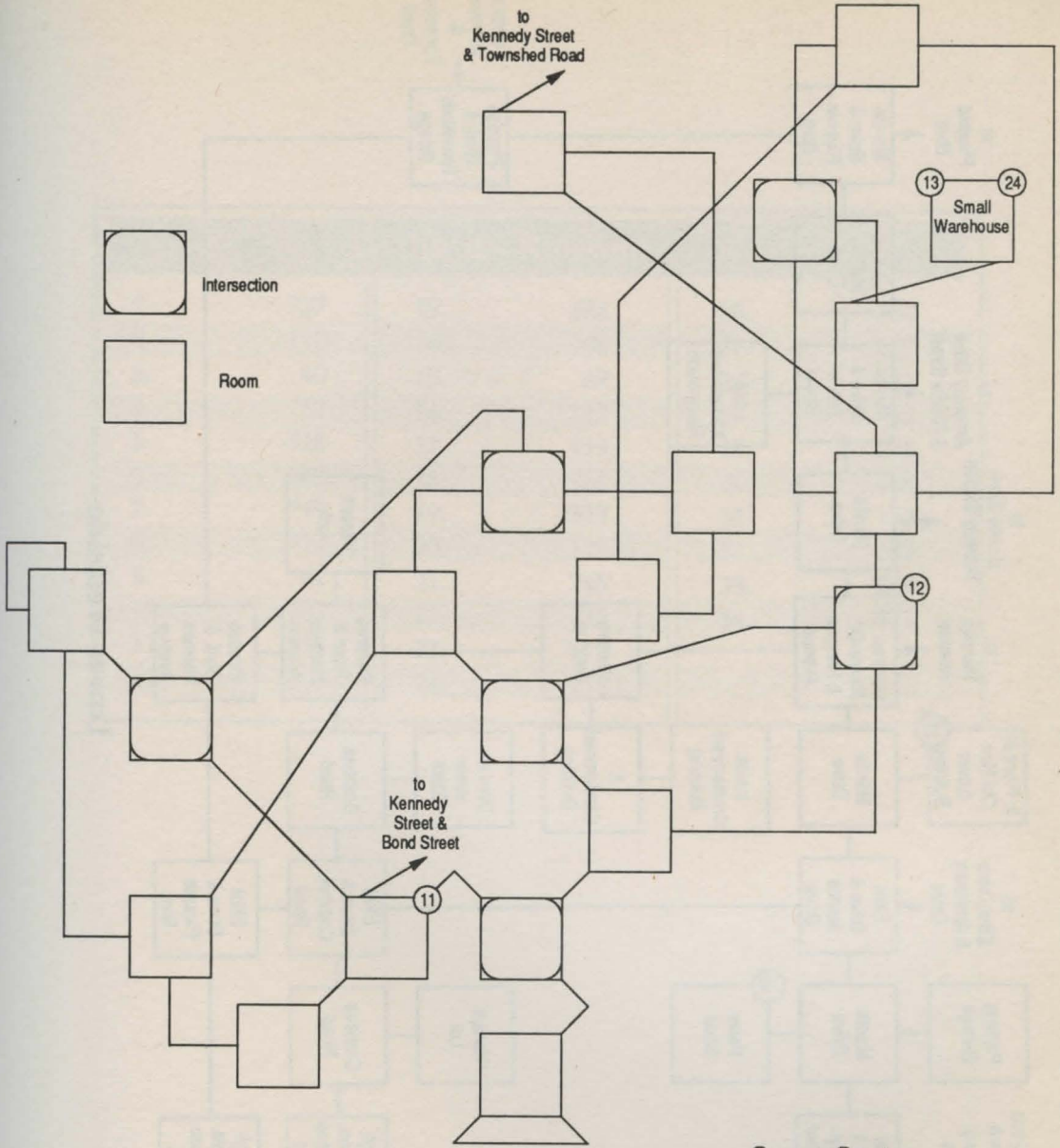

Sewer System

Twilight's Ransom

Twilight's Ransom

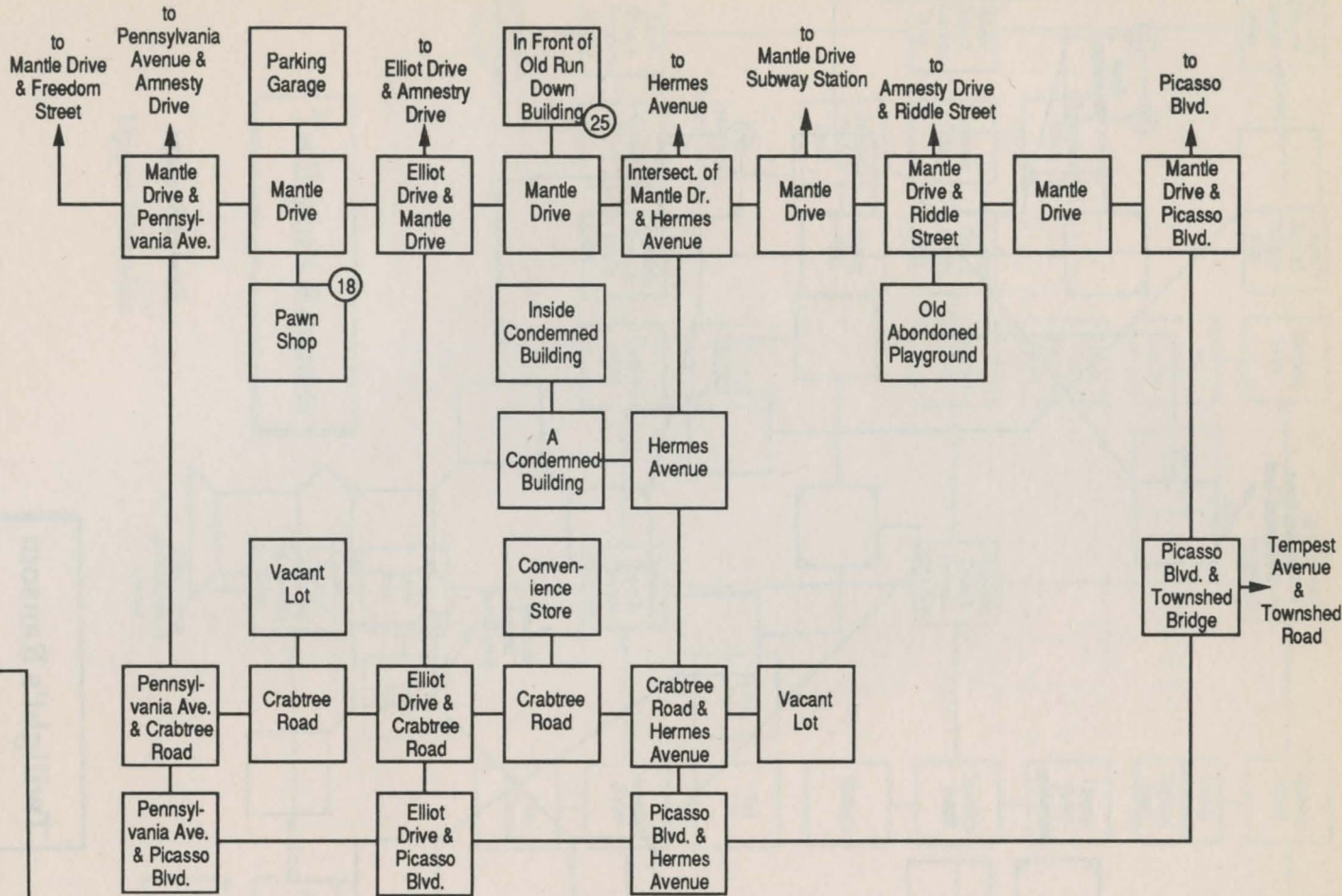

Lower Westside

Twilight's Ransom

1.	727	13.	484	25.	508
2.	110	14.	906	26.	850
3.	40	15.	69	27.	32
4.	251	16.	222	28.	793
5.	528	17.	419	29.	224
6.	242	18.	456	30.	498
7.	749	19.	535	31.	132
8.	714	20.	126	32.	382
9.	61	21.	763	33.	209
10.	300	22.	715	34.	573
11.	455	23.	699		
12.	504	24.	278		

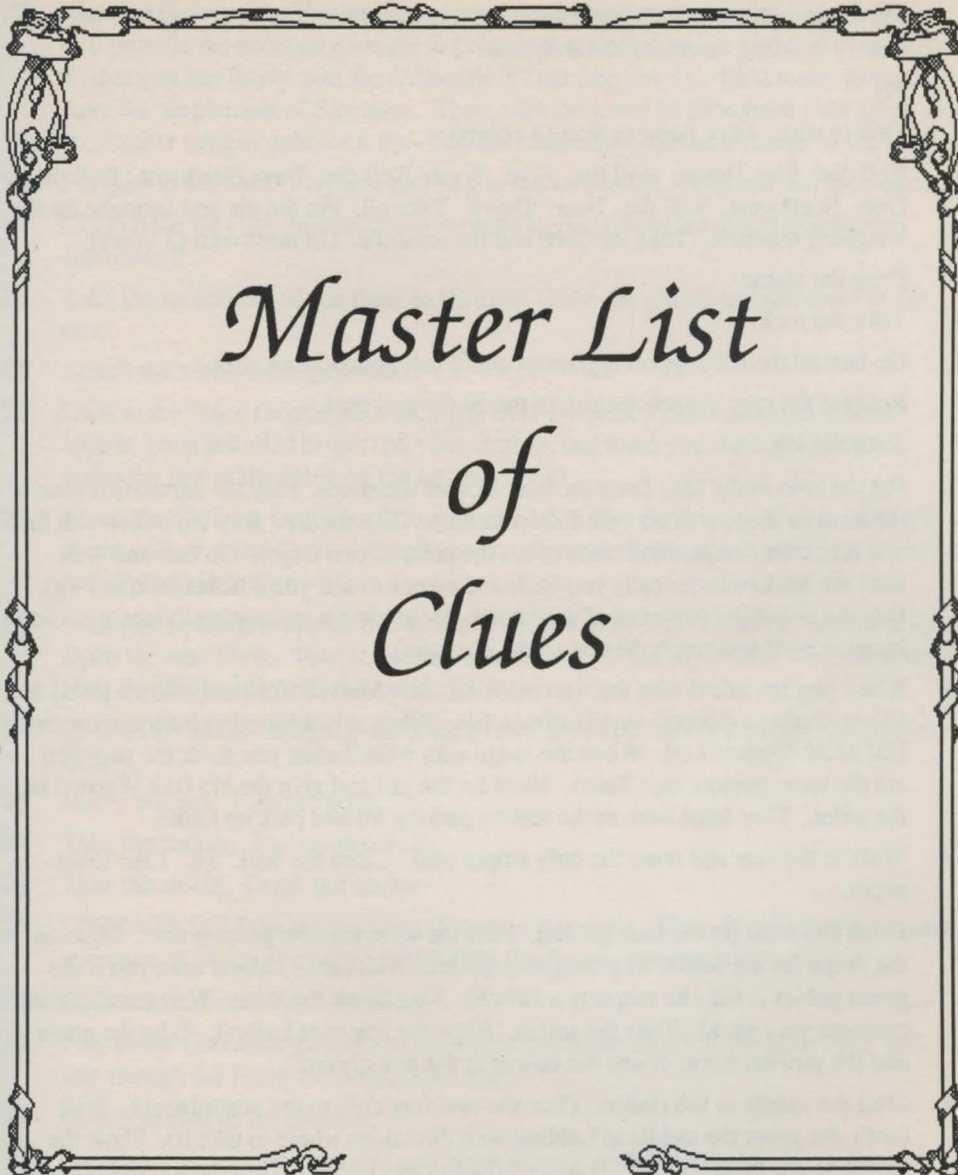

*Master List
of
Clues*

- 1 Move through the colored squares in the order of the colors in the rainbow ultimately winding up on the white square.
- 2 Fly.
- 3 Talk to man. Give purse to man (3 points).
- 4 Roll die. Six. Down. Roll die. Five. West. Roll die. Two. Northeast. Roll die. One. Northwest. Roll die. Four. Down. Take all. Put the die and anticube on the weighing machine. Take the cube and the anticube. Go northwest (3 times).
- 5 Drop the statue.
- 6 Take the rock.
- 7 Go behind the life support apparatus and: Push button. Exit vent.
- 8 Replace the cap. Attach the pen to the ne (or nw) post.
- 9 Take the log.
- 10 Put the coin in the hat. Drop the hat. Doofer the shoes. Play the harmonica (one of the tourists drops a silver coin into your hat). Take the hat. Buy the ticket with the one ferg coin (the stationmaster raises the price to two fergs). Go east and wait until the stationmaster calls you back and agrees to sell you a ticket for one ferg). Buy the ticket (it blows out of your hand. Head after it attempting to take it at each location until you reach the end of the platform).
- 11 When you are asked who the warrant is for, say: Marvin Hoffman. When asked for substantiating evidence, say: Hoffman file. When asked for other information, say: FBI Most-Wanted List. When the judge asks what makes you think the two men are the same person, say: Tatoo. Head for the jail and give the No Bail Warrant to the jailer. Then head back to the station parking lot and pick up Laura.
- 12 Walk to the rear and enter the only empty stall. Close the stall. Sit. Take toilet paper.
- 13 Drink the wine (in the blue goblet). Pour the wine into the green goblet. Squeeze the drops (in the bottle) into the green goblet. Wait (until Lafond asks you if the green goblet is his - he suspects a switch). No. Drink the wine. Wait (until Lafond caresses your neck). Take the spices. Blow the spices at Lafond. Take the garter and the powder horn. Shine the mirror in the moonbeam.
- 14 Mail the saddle to the station. Give the two-ferg coin to the postmistress. Wait (until she gives the saddle to Lebling with directions where to take it). Show the mouse to the postmistress. Turn the bottom right handle. Turn the top right handle. Turn the bottom right handle. Turn the bottom right handle. Turn the top left handle. Open the safe. Take the dragon charm. Examine the dragon charm.
- 15 To continue up the snowy mountain path, you must climb the big rock in the center of the screen to get on the next plateau.
- 16 Take the snake skin.

- 17 Wait (until the mother hungus clammers onto the bottom of the idol's maw. This will provide the necessary weight to balance the seesaw action of the idol's mouth so that you can safely take the Crocodile's Tear (the jewel)). First make sure you have the implement of Sayonara. Then, take the jewel (it slips from your grasp and the mother hungus gobbles it up. You are catapulted into the gizzards of the idol).
- 18 Put gum in keyhole. Play lute and sing urfanore pendra. Go south and then east.
- 19 CLOSE the lid (The dumpster will soon be loaded onto a truck and transported elsewhere).
- 20 Take the secateurs and put them in the case. Take the gloves and put them in the case.
- 21 Attach the wires to the generator.
- 22 Look at the fence (notice the 6 inch gap over the closed gate - Jamison should appear, pin a jewelled brooch on your clothes, and hand you the coffer that was under the bed in the cabin on the Lafond Deux).
- 23 Inside the Caffeine Castle, walk over to the table and: Sit down. After a while the phone will ring and Carol will call you to answer it. Stand up. Approach the phone and: Talk to Hamilton.
- 24 Wait (for Lebling to appear and then put the parcel in Xam's mailbox and lock it). Open the matchbox. Take the match then light it. Light the candle with the match. Heat the plastic key with the candle (twice).
- 25 OPERATE the newspaper (you bought from the blind man in the train stations) on Gabby.
- 26 Marry the girl. Kiss the bride.
- 27 Take the paddle. Pull on the chain.
- 28 Take the shield. Drink the nectar.
- 29 OPERATE SELF on paperweight (found in Ventini's office. It separates into two parts one of which is a dart). OPERATE the dart on the dart board.
- 30 Open the cushion. Take the note.
- 31 Play poker (Between games you must type the word: Deal) Eventually, you will win enough for Frank to congratulate you.
- 32 Give 5 dollars to the bouncer.
- 33 Attack and defeat the crocodile and bloodworm (in whatever rooms they appear. This will take a bit of doing but it can be done. The implement of Annihilation is particularly helpful on the powerful bloodworm. You can also heal yourself in between at any of the three support towers).
- 34 Pray. Rest (continue to do this even after the Demon appears and starts attacking you. Eventually the wind will blow him away).

- 35 Play blackjack and/or slots until you accumulate \$250 (this is the casino bank's limit).
- 36 Give the holo to Weelomin (he gives you a yellow gem in return). Show the yellow gem to the guard.
- 37 Search. Open chest. Examine chest. Take the gold sovereign.
- 38 Dial the telephone (behind the desk on the right). 1-312-555-3382. When Taber asks how he can help you, say: Information about Taselli.
- 39 Wait (repeat until a golden bundle of fur jumps out of the forest and then ducks behind the tree). Look behind the tree (you see a minx which you must now proceed to protect from its owner). Hide the tracks. Wait (repeat until an angry man comes out of the woods looking for the minx. Continue to wait until he disappears). Pet the minx. Wait (repeat until the minx digs up a chocolate truffle in the dirt). Take the minx and the truffle (the minx will eat the truffle. Don't worry you will find another later on). Head back to the magic shoppe. Don't forget to take the minx with you as you climb up the support tower.
- 40 Look under the Ford. Take the bolt cutters.
- 41 Put all in the pack except for the dagger and the implement of Annihilation. Cut the onion with the dagger. Point the implement of Annihilation at the dornbeast (that should take care of it). Open the chest (twice). (You are transported to the Plane of TransInfinite Splendor. You can only go here one time. After returning to the Lamp Room, proceed as follows). Take the sextant (it's in the debris). Look inside the chest. Take the palimpsest and the vague outline. Close the chest then take it (you will have to put all your other inventory in the pack first since the chest is large).
- 42 Join the procession.
- 43 Take the charm (from the chandelier).
- 44 At the left of the screen, go up and enter the grotto. Take the glowing gem. Go back in the water and: Take a breath.
- 45 Open the swag bag. Turn on the lamp.
- 46 At the place you exit the cave: Take the glowing gem (which fell out of your hands as you tumbled down the cave).
- 47 Enter the boat. Put the oar in the oarlock. Take the anchor. Launch the boat.
- 48 Untie the creature (hanging from the rope).
- 49 Push the right button.
- 50 Drop the rabbit into the pit.
- 51 Look inside the mailbox (it should now contain a postal note). Take the note then read it (it tells you how to retrieve an undelivered parcel addressed to you)
- 52 Open the safe. Put the rhino and burner in the safe. Close the safe.
- 53 Take the brush.

- 54 Throw bag.
- 55 Use the sword. Throw the wine at the demon. Use the key. Use the plunger. Use the key.
- 56 Knock on the door. Pull the guard's leg.
- 57 Board the ship (2 points).
- 58 Take the holy grail.
- 59 OPERATE the unusually shaped key (from the telephone in Siegel's office) on the slot machine on the right. OPEN the slot machine. Take the diary and business card. OPEN the diary and EXAMINE it. EXAMINE the card.
- 60 When you get to the stream, walk upstream.
- 61 Ask the librarian about PS 3511 I-912 t29. Wait (repeat until she goes to answer the phone and leaves the card on the desk). Take the card. Read the index card.
- 62 Drop the anchor. Wait (repeat until the clock reads an appropriate time for high tide as determined from the weekend time table supplied with the game). Take the moss.
- 63 Take the small crate.
- 64 Call a taxi. Enter cab (at the rear door of the taxi). When he asks you where you want to go type: casino. Pay the driver. Get out.
- 65 Take all from Spock. Take the polyp. Spock, analyze the polyp. Set the phaser to wide beam. Fire the phaser at the burrowers (repeat until a ribbed sphere is dislodged from the sand). Take the ribbed sphere. Fire the phaser at the burrowers (repeat until a violet sphere appears in the sand). Take the violet sphere.
- 66 Take the shard. Take the gold.
- 67 Drop the carpet. Sit on the carpet. Fly the carpet.
- 68 Examine grate. Open grate. Take the spear.
- 69 Uproot the yucca cane (or simply, dig in the dirt). Open the cloth. Take the key and unlock the door.
- 70 Look in the car. Take the wallet.
- 71 Wait (until Smeagol disappears and then returns with a rabbit). Take the rabbit. Go fishing (repeat until you catch one). Take the fish. Go fishing (repeat until you catch another one). Take the fish. (Somewhere along now Faramir will enter and ask you to identify yourselves). Faramir "hobbits". Wait (until the Oliphaunt enters). Go north. Wait. Go south (the Oliphaunt should be gone. Take the frying pan. Break the branch (twice). Drop the twigs. Sam "give the matchbox to me". Open the matchbox. Light the match. Light the twigs with the match. Put the large fish in the pan. Put the pan on the fire. Take the large fish and the pan. Eat the fish. Repeat the above procedure to cook and eat the rabbit. Put out the fire (if it did not already go out by itself).

- 72 Watch the lights (there is a searchlight on top of each tower. The directions that they point are now displayed on the status line at the top of the screen. When all three searchlights are pointed away from you, immediately go north).
- 73 Take the holo and shake it. Soon, you are informed that the ship has been hit by an unidentified attacker. After asking Sulu and Berryman to: analyze the attacker, you realize that you need help from a more competent crew person. Call Spock on the intercom: Kirk to Spock. After Spock arrives, ask him to analyze the attacker and then the bird of prey. Sulu, arm the photon torpedos. Lock the torpedos on the image. Fire the torpedos at the image (repeat until the bird of prey is scorched and inert). Yes (when Uhura asks if she should put through communication with the Romulan vessel). Spock, describe the damage.
- 74 Take a shower as before but this time change into street clothes (T-shirt and jeans). Take the gun and ammunition. Put the patrol car keys on the keyboard on the way out.
- 75 Enter the jar.
- 76 Examine books. Open book. Read book (three times). Now, go back and get your horse from the smithy.
- 77 Ask the butler for Mycroft. Give the ring to the butler (take note of the password given to you by Mycroft)
- 78 Take the rhino.
- 79 Close the hatch. Push the left button. Turn the wheel. Open the door.
- 80 Sit down (in the chair to Jack's left). Wait around for the party.
- 81 OPERATE your driver's license (from the wallet) on Gabby.
- 82 Get out of the uniform, and change back into your trousers and trenchcoat. OPERATE Bondwell's driver's license on Gabby.
- 83 Approach the desk and: Ring bell. Check in. Pay clerk.
- 84 Take the blue die.
- 85 Put the violet key in the circular slot. Turn the blue key. Turn the green key. Turn the yellow key. Turn the red key. Turn the violet key (you get the diploma).
- 86 Blow the whistle (twice). Enter the cab. Buckingham Palace (when asked where you want to go).
- 87 Go left. Continue to "go right" until you reach the Stop Room.
- 88 Throw silver sphere. Throw gold sphere. Throw platinum sphere.
- 89 Open gun locker (to the left of the door). Put gun in locker. Close gun locker. Push buzzer (to the right of the door). Take the prisoner inside the jail. After some preliminaries, the jailer will order you to: Remove handcuffs. After depositing Art in cell #1, leave the jail. Don't forget to pick up your gun from the locker.
- 90 Enter the cask. Cut the line with the dagger.

- 91 Turn the wheel.
- 92 Open the drawer. Take the thimble (1 point). For fun, go to sleep in the baby bear's bed. The papa bear will catch you and throw you out of the house.
- 93 Unlock the mailbox with the plastic key (there should be nothing inside of it now).
- 94 Take the saddle.
- 95 Give the candy to hairy momma.
- 96 Ask officer about form 17D-16B. Give the sandwich to the officer.
- 97 Listen to the magpie (he gives you a pair of spectacles).
- 98 Take the coconut (of course, the Implementors won't let you near it. Keep repeating this command and eventually the Implementors who have been playing "catch the coconut" will drop it at which point it will be picked up and gobbled up by the Urgrue. Continue to wait until one of the Implementors offers you a goblet of nectar). Take the goblet. You are transported back to the place you left Quendor, e.g., the Edge of Storms.
- 99 Give form 69B-12C to the fox.
- 100 Unlock the mailbox with the plastic key. Take the parcel then open it. Examine the charm. Read the letter.
- 101 Take the cask.
- 102 OPEN the night table. OPEN the slips and EXAMINE them. OPEN the wardrobe. OPEN the vacuum cleaner. OPERATE pocket knife on bag (inside vacuum cleaner). Take the envelope and OPEN it. Examine the letter. Take the policeman's uniform (belonging to McMurphy). Remove the trousers and trenchcoat (OPERATE them on SELF). OPERATE the uniform on SELF.
- 103 Tie the rope to the signposts. Wait (until a mounted hunter enters waving a lasso. He will run into the rope and fall to the ground. If the hunter then strikes at you and the Valkyrie takes you to the clouds behind Paradise Gate, just wait until you are outside the gate and then come back here). Take all. Take the lasso. Untie the rope. Tie the lasso to the rope.
- 104 Fill the flask with water. Drink the water.
- 105 Put the cheese on the mouse trap. Set the mouse trap. Drop the mouse trap.
- 106 Take the reprogrammer (it shows up in your inventory as the "recruiting device". Shortly thereafter you will be thrown back out to the glowing gate).
- 107 Answer the telephone.
- 108 Take the salt.
- 109 Move the statue.
- 110 Open the mailbox. Take the pink envelope and open it. Read the note. Read the documents. (This is the first of three sets of documents hidden by Maria that you must find).

- 111 Take the green die.
- 112 Take the crystal.
- 113 Take the rope. Tie the hawser to the rope.
- 114 Turn the faucet.
- 115 Get rock. Give form 43A-81G to officer. Steal form 69B-12C. Shoot the officer.
- 116 Wear the helmet.
- 117 Burn the plant with the lamp.
- 118 Give bread to man (he tells you an important piece of information about the Solomon sword you found inside the white chapel).
- 119 Wear armour. Open door.
- 120 Open the gate (of the chicken coop). Catch a chicken (you must be near one to catch it). Pluck a feather (1 point).
- 121 Put oil on the door.
- 122 Drop the log. Sam "drop the log". (Together with Sam go back and drag the other two logs here and drop them). Take the rope. Make a raft. Take the branch, shirt, and small sword. Sam "take the bread, beautiful sword, and matchbox". Get on the raft (Sam should follow suit. If not, tell him to get on the raft). Smeagol "get on the raft". Pole the raft with the branch.
- 123 Push the button. Take the coin.
- 124 Open box 600. Take the topaz.
- 125 Take the scale.
- 126 Tell the man about the rifles (you found in the crate).
- 127 Take the mace.
- 128 Topple the cart.
- 129 Take the horseshoe. Kiss the unicorn. Point the wand (or other implement) of Levitation at the unicorn (it races out of the stablehouse). Point the wand at the saddle (it too rises out of the stall). Take the saddle.
- 130 Examine the ground. Take the snake skin (between the prickly cactus and the rock in the center of the screen) (1 point).
- 131 Open the stool. Take the plastic bag.
- 132 Wait until you hear where Maria has been moved to. Then continue to wait until the meeting is adjourned. Make your way out of the night club in a hurry.
- 133 Wait (repeat until the minx pulls up a truffle from dirt around the base of the oak tree). Take the truffle (don't let the minx eat this one).
- 134 You will usually encounter a highwayman here. Fight and defeat him and you will get his saber and silver sovereign.

- 135 Enter the mirror.
- 136 Go through the waterfall.
- 137 Drop dirt (in the hopper).
- 138 Open the door. Read the scroll. Show the scroll. Throw the scroll.
- 139 Enter the park and as you approach the picnic table: Draw gun. Load gun. Go behind one of the bushes. Radio Laura that you are concealed. Stay hidden until first one man enters the picnic area and then soon thereafter another. When the two men begin to argue over the contents of the envelope: Radio Laura. While still hidden behind the bushes say: Stop! Police officer. Come out from behind the bush and approach the remaining suspect with your gun drawn. Handcuff suspect. Read rights. Search suspect. Examine ID card. Examine bag. Question Simms (twice). Follow me. When you get to the patrol car: Question Colby (twice). Put the two criminals in the back seat of your car, cart them off to jail and book them for drug dealing. Head back for the station parking lot and drop off Laura.
- 140 Listen to Morgan's instructions. After Hamilton calls and Morgan hangs up, go behind the desk and: Examine the telephone (note the number: 555-6674).
- 141 Nothing to do here except get the Philosopher's Stone that Merlin gives you to place on an altar that is different from the rest.
- 142 Look at the tools. Take the gloves and the bolt-cutter.
- 143 Take silver sphere. Take gold sphere. Take platinum sphere. Juggle spheres (remember what the sign at the ledge said about "spinning the globes into a wheel"). Pick up the key on the way back through the Ice Room.
- 144 Fill bottle. Breathe. Take fourth stave. Drop fourth stave.
- 145 Show the ticket to the inspector (when he asks for it). Push the button. Wait (repeat until the bus stops at Neverending Lane and the doors open). Exit.
- 146 Take the halyard.
- 147 Move altar.
- 148 Approach the bar and: Give money to Woody.
- 149 Take the cue. Open the red ball. Take the ring.
- 150 Take the noose. Tie the noose to the rope.
- 151 Take the rose (from the table). Give the whisky to the drunk.
- 152 Wait (repeat until the butler tells that Lafond requests your presence in his room - remember his invitation while you were dancing with him).
- 153 Tie the rope to the tree.
- 154 Sam "drop the bread".
- 155 Look at the flasher. Talk to the flasher.

- 156 Wait (a bottle appears in the river). Continue to wait until the bottle flows downstream and disappears under the bridge. Look under the bridge. Take the bottle.
- 157 Buy the lute with the cheque. Get all from the bag. Put the lute in the bag.
- 158 OPEN the overcoat and take the .38 revolver, two quarters, and \$10 bill. Open the drawer (on the floor) and take the penknife, box (of bullets), safe deposit box key, and brass key. OPEN the gun. OPEN the box. Drag the bullets into the gun, i.e., load it. Also take the flashlight before leaving your apartment.
- 159 Push the brick. Reach into the chamber. Take the booklet. Read the catalog.
- 160 Give the tuna to the shark.
- 161 Get the wafer.
- 162 Remove the cap (on the pen). Push the button (about 4 times - the number of times you push the button depends on how quickly or slowly you move once you arm the device until you are at the place you want it to explode).
- 163 Dial the telephone. 411. Cobb. Dial the telephone. 555-2622. Dial the telephone. 411. Williams. Dial the telephone. 555-4522. When Williams asks who's speaking, say: Sonny Bonds. When he asks what he can do for you, say: Hoffman.
- 164 Look at the floor. Take the amulet.
- 165 Take the amethyst charm (from the sack). Examine the amethyst charm. Put the bung in the sock. Put the sock in the hole. Put the canoe in the water. Enter the canoe. Take the paddle.
- 166 Turn on the lantern. Squeeze the moss. Wait (until you idly scratch an itchy finger). Look at the finger. Point the implement of Sayonara at myself. This will get you out of here. Wherever you are deposited (hopefully somewhere in the jungle), head back to the quicksand. Turn off the lantern at your earliest convenience.
- 167 Take the jeans. Wear the jeans.
- 168 Look inside the cage (you should now see a burning fuse near the pile of gunpowder kegs).
- 169 Cast glow (you have learned the "sword" spell).
- 170 Oojimy the stool. Take the stool.
- 171 Spock, analyze the cave. Set the phaser to overload. Drop the phaser. Immediately go southeast and then after the explosion go northwest bringing you now to the rock slide.
- 172 To defeat the Dark Sorcerer you must use a weapon that is not made by the hand of man. Remember the dagger Queen Guenever (certainly not a man) gave you. Break the mirror. Take the reliquary. Examine the desk. Open the second drawer. Examine parchment (it explains how to move once you enter the Wasteland, i.e., like a knight in the game of chess - two moves forward (north) and one move right or left (east or west)).

- 173 Approach Woody and tell him: Frank sent me.
- 174 Ask Nick about the keys. Buy the keys.
- 175 Unlock the chest with the key. Open the chest. Take the gold standard. Take the cord. Tie the cord to the rope.
- 176 Take first stave (it transforms into a shovel). Wear boots (you float up to the ceiling). Dig (remember what the pendant said). Take dirt.
- 177 Move to the far right of the ledge and tie the rope to the fire escape. Tie the rope around the waist. Break the window with the hammer. Take the pills. Grab the fire escape. Untie the rope.
- 178 Use toothbrush in keyhole.
- 179 Attack and defeat ghoul and the undead warrior (the latter is done away with by hitting him with the vial). You will also find a gray potion somewhere in the ruins.
- 180 Give the gem to the lioness.
- 181 Wait (for the butler to ask you for an invitation to the ball). Give the invitation to the butler (Alternately, if you never took took the invitation, you can: bribe the butler with the banknote).
- 182 Take the candle and the match box.
- 183 Put the scarab in the hole. Immediately go north when the door opens.
- 184 Take the marrow and the garlic.
- 185 When Sweet Cheeks asks if you got anywhere with the bartender, say: Yes. When she asks if you have enough money to gamble in the big game, say: Yes. Dial the telephone. 555-6674. When he asks who's speaking, give your real name: Sonny Bonds. Dial the telephone. 411. Lytton Cab. Dial the telephone. 555-9222. When asked where the pickup is, say: Hotel Delphoria.
- 186 Look at the buildings (note the positions (south, middle, or north) of the open windows on the 3rd, 4th, and 5th floors).
- 187 Give the fish to the man. Take the scroll.
- 188 (Assuming the cat is here — if not go to the place where it is). Catch the cat (you must be right up against it, else it slips away). Take the hair. Unlock the cabinet with the key — you get the magic wand. Examine the books (there is a glint of metal behind one of the books). Approach the eastern bookshelf, and move the book revealing a lever attached to the back of the bookshelf. Pull the lever (a trap door appears in the floor).
- 189 Drop pillow.
- 190 Troll, go south. Rainbird, go south. Dragon, go south (his smoke sets off an alarm causing the emergency exit to open).
- 191 Throw the rope. Climb down the rope.

- 192 Pry the stone with the stick.
- 193 Extend the ladder. Put the ladder across the crevice.
- 194 To leave this place, type the word: Word. (The aliens told you to simply say the word). Enter the hole in the ground that is revealed when the aliens move the boulder.
- 195 A mouse is usually here; else wait for it. Look under the bed. Close the door. Put XXX in the hole ("XXX" is any inventory item). Catch the mouse. Wait for mouse (to reappear from crack in the wall). Put YYY in the crack ("YYY" is any other inventory item). Catch the mouse. Wait for mouse (to reappear from crevice in the wall). Put ZZZ in the crevice. Catch the mouse (There are no more exits for it to escape). Drop the sack (The mouse will run inside it). Take the sack. Take XXX and YYY and ZZZ. Cast eye on hole. Eye, enter the hole. Take the card.
- 196 If a druid priest appears, fight and defeat him. Put stone on altar. Say Uther Pen-dragon (remember what you read in the book in Guild Hall).
- 197 Drop the teddy bear. Take the wires.
- 198 Approach the window on the right. When the clerk asks to help you, say: Where is the judge? I need a No Bail Warrant. When the clerk says that the judge can only be interrupted for an emergency, say: It is an emergency.
- 199 Ask the executioner to unlock the cell.
- 200 Enter the tower (if you have timed this properly, the guards will come after you. However, the pen will explode, the tower will fall over, and you will land in a small heap across the border).
- 201 Read the inscription. Lightning.
- 202 Shake the tree. Take the coconut. Drop the jar. Take the succulents.
- 203 OPERATE the newspaper clipping (with the address of Joe's Bar) on Gabby.
- 204 Nothing to do here. Just observe that the pool of radiance darkens the chocolate truffle's color into a rich, mouthwatering brown thus reviving and also preserving it. Put the truffle in the pack. Blow the whistle. Don't forget to take the minx with you when you climb aboard the pterodactyl.
- 205 Take the crystal ball (from the table).
- 206 Examine siege (it should now say that it's Percival's seat. If not you haven't performed enough good deeds yet. Go back and see if you have prayed everywhere you were supposed to. Chances are you missed some place). Sit on the siege (you learn what you must do after you enter the Chapel Perilous).
- 207 Take the empty cup (on the table) (1 point).
- 208 Walk completely around the PD car (on the left opposite your Corvette) to give it the necessary safety check. Open the door and enter the car. Close the door. Take the nightstick. Start the car.

- 209 Shoot the bald man with the gun. Untie Maria.
- 210 Change to slow animation speed. Climb down the wall (being careful not to touch the sides) until you are on the ledge on the upper left. Enter the cave and walk to the right. You will emerge from the cave on the ledge on the upper right. Walk to the end of that ledge and move onto the wall. Climb down the wall (again being careful not to touch the sides) until you land on the ledge on the bottom middle of the screen. Walk to the right, enter the cave, and walk to the left. You will emerge from the cave on the ledge on the bottom left of the screen. Walk to the right on that ledge and move onto the wall. Climb up the wall and then over to the right finally landing on the ledge in the middle of the screen. Enter the cave and walk to the right. You will emerge from the cave on the ledge on the bottom right of the screen. Just walk to the right along that ledge and you will be on the next screen.
- 211 Ask officer about form 16D-970. Shoot the officer. Get form 16D-970. Continue winding your way back through the red tape.
- 212 Get on the brace (wait until the guards are far enough away toward the right and left towers and facing in their direction).
- 213 Tell Abu to pull the lever.
- fake* 214 Don't do anything.
- 215 Approach the mailbox (on the upper portion of the cliff) and: Mail the order form. Take the whistle. Fall off the cliff, and approach one of the clusters of balls on the ground. Take the spore. (Be careful not to break or open it yet).
- 216 Take the keys.
- 217 Give the wine to the man (the beggar). Dial the telephone (555-6969). Call a cab and go back to the casino. Play a little more blackjack and/or slots until you have about \$175.
- 218 Pull the trigger. Search the mutants. Take the wrench and the keys.
- 219 Take the rose. Open the lid of the organ. Put the goblet (with the butterfly on its lid) in the organ. Close the lid of the organ. Set the dial (on the organ) to the clock. Turn the crank backwards. (The butterfly is transformed into its youthful version - a caterpillar). Open the lid of the organ. Take the caterpillar. Take the goblet then drop the organ.
- 220 Take the stave (or other implement).
- 221 Stand under the arch. Turn over the hourglass.
- 222 Give the junior burger to the dog.
- 223 Say to mynah, hooray (repeat until the bird echoes you with "hooray"). Join longer line.
- 224 Close the stall door (so that the removed ceiling tile will not be noticed by anyone visiting the restroom).

- 225 Give the ordering card to the clerk. You want to buy an economy carpet so when he asks you for the first two letters of the product of your choice, respond with: CP. Next give him the five-digit code number: 65011. Finally, give him your Arabian Express charge number: RJ8906 TA3756 (Later in the game you will receive what you ordered).
- 226 (Assuming that the human character followed you in here. Else, restore back to the Necropolis and try again). Cast glow. Take the coin. Wait (until the vampire teaches you the "knives" spell).
- 227 Buy the clips.
- 228 Bow (or kneel).
- 229 Get the soap. Wash the mouth.
- 230 Open the coffer (the lock on it is now smashed). Take the invitation. Throw the coffer through the window. Sit on the ledge. Remove the frock. Wear the shirt and the breeches. Grab the ladder.
- 231 Take the spear.
- 232 Sit on the pedestal. Say XXX (where "XXX" is the name of the character that you assigned to yourself at the beginning of the game). Say Death to Colnar. Say teleportation.
- 233 Look rabbit. Give water. Rabbit. Take wand.
- 234 Drag the log. Sam "drag the log".
- 235 Dip the fly wings in the essence. Fly into the hole in the tree (5 points). When you come out, type: Fly begone! Myself return!
- 236 Take the hat then take the stethoscope. Wear the stethoscope. Listen to the girl with the stethoscope. Open the black bag. Open the blue bottle then open the brown bottle. Take the yellow (for a slow heartbeat) or orange (for a fast heartbeat) pill then give it to the girl.
- 237 Hit the skeleton (with the shillelagh). (Repeat until it crumbles into a heap of bones). Take the amulet. Wear the amulet. If the lantern flickers and goes out, just say: Blarn (or whatever word was on the scroll). It is a replenishment spell which can be used to relight the lantern.
- 238 Take the pipe. Open the stopcock. Wait. Close the stopcock.
- 239 Take the matchbook.
- 240 Put radio (extender) on table. Put patrol car keys on keyboard.
- 241 Give Rambone the tonic.
- 242 Examine the files. Open the folder. Look for Maria's locker number (it changes each time you play the game).
- 243 Show i.d. to Bonzo.

- 244 Take the rods.
- 245 Knock at the door.
- 246 Look under the bed. Open the tub. Take the maggot.
- 247 Put gold sphere in shaft. Give violet sphere to Delighter. Mumbling. Give ribbed sphere to Delighter. Smiling. Give small sphere to Delighter. Spinning. Take all.
- 248 Take the saddle.
- 249 Close the door. Examine the dial (repeat until the needle points to about the "1/2" mark)
- 250 Show the Crown Jewels to the guard.
- 251 Drop the pink envelope. Put the trash can under the awning. Climb on the trash can. Put the bolt cutter on the awning. Climb on the awning and take the bolt cutter.
- 252 Light the lamp with the flint.
- 253 Untie the rope. Swing on the rope (You slam into Lafond and knock him unconscious. You wind up in the ballroom.) Take the garter and the horn.
- 254 Wait 1 (repeat until the tomb opens). Look inside the tomb (you have learned the "detect" spell). Go back to the graveyard and take the sack.
- 255 Dig. Get the vase. Get the worms.
- 256 Enter the desert (from east to west in either of the four locations) and immediately face north, south, or east (press the up, down, or right arrow keys). This prevents you from facing Medusa who is coming from the west. You have to be quick about this or else she will turn you into stone. Wait until Medusa comes close to you, then type: show the mirror to Medusa. (This turns her into stone) .
- 257 Shine the beam at the wax with the mirror. Take the gem.
- 258 Push button. Enter the closet. Look closet. Take the basket. Take the overalls. Take the lighter.
- 259 Kill assassin. Drink liquid (in the vial). Kill assassin. Search assassin. Take chime.
- 260 Cast cold at fire. Examine the grate (you have learned the "eye" spell).
- 261 Give the card to Boothe. Take the ring. Toss the ring. Take the mug.
- 262 Light the clue paper with the tobacco. Take the torch then light it with the clue paper. Take the wax head (from the Charles I statue). Melt the wax head with the torch. Take the gem.
- 263 Take the mat. (If you want, you can first sit on the mat in which case Lorenzo "Buck" Way will appear. He doesn't have anything you want, however, so there is no real reason to do this).
- 264 Grab the rope. Swing into the cave.

- 265 OPEN telephone. Take the unusually shaped key.
- 266 Open sesame. Enter the waterfall.
- 267 Raise the phial. Wait (until the spider appears and rears up to attack Frodo). Galadriel.
- 268 Take the washing line. Tie the washing line to the rope.
- 269 Talk to the captain. Say "ready". Hell.
- 270 Take the handbook.
- 271 Guard, the password is XXXX (where "XXXX" is the password given to you by Mycroft in the Diogenes Club)
- 272 Put the ampoule in the hat. Wear the hat.
- 273 Inside the Caffeine Castle, Talk to Carol. Then go next door to Wino Willey's. Talk to the men. When the men surround you and are about to accost you: Hit the men with the nightstick. After they leave: Talk to the the girl. Do you have information about drugs? Return to your car and radio headquarters.
- 274 OPERATE SELF on boarded up window.
- 275 Take the tether (that the goat is tied to). Tie the tether to the rope.
- 276 Cast magician on me (since you have learned all 21 spells, you are now qualified to become a magician). Recruit rainbird.
- 277 Enter the south hole.
- 278 Take the rifle. Tie the red balloon to the blue balloon. Tie the blue balloon to the rifle. Put the rifle under the skylight (the red balloon passes through the open skylight thus allowing identification of the building from the outside).
- 279 Give water to the parrot. Take the staff. Put the staff in the hole. Enter the statue. Light the torch.
- 280 Turn off the lantern (this is very important as you will need to use it again later on in the game). Give the bottle to the cook (he turns over the onion to you. Leave it here for now and set out to find the implement of Annihilation. Head toward the Spooky Area first.)
- 281 Wear the glasses. Examine the teddy bear. Take the yellow key and the teddy bear. Drop the glasses.
- 282 Put the cube, heart, eye, berries, and snake skin in the cauldron. Open the satchet. Take the anticube.
- 283 Sit on the seat. Hurry on back to your bedroom. On the way there, you may have to repeat the directional commands several times to get them to be successful.
- 284 Marry Fawn.
- 285 Get bottle.

- 286 Walk up to where Vohaul's body lies and: Search body. Approach the flashing screen on the console and: Look screen. Type: SHSR.
- 287 Enter the window.
- 288 Take the bread. Eat the bread (you remove the pelican charm from your mouth). Examine the charm.
- 289 Take the pacquet and the crayon. Open the pacquet.
- 290 Pull the torch.
- 291 Examine the statue. Hide behind the bush. Wait (repeat until a platypus appears, opens a secret compartment in the statue, removes a jar and then opens it. Watch what the platypus does with the circlet contained in the jar. You will want to do this later on in the game. Continue to wait until the platypus puts the jar back in the statue). Leave the bush. Open the compartment. Take the jar. Take the bush (actually you get only a morgia root from it). It's now time to leave so: blow the whistle. Climb on the pterodactyl. Up.
- 292 Nothing to do here but listen to Morgan.
- 293 Pray. Search. Take the sword.
- 294 Take the lamp.
- 295 Take the cactus (next to the large rock) .
- 296 Burn second stave.
- 297 Take the card from Sam. Remove the visor.
- 298 Give sugar to the horse. Put horse barding on horse. Mount horse.
- 299 Open the sack. Take the sieve. Sieve the flour with the sieve. Take the pelican charm (from the flour).
- 300 Take the flashlight.
- 301 (The desert maze is a "moving" maze and thus cannot be mapped. You will come upon the oasis merely by wandering around in random directions). Fill the flask with water. Drink the water. Tell Abu to kill the snake. Take the figs.
- 302 Stand in front of the desk while Morgan commends you on your hard work to keep Hoffman in jail. Morgan tells you to check out the black book from Russ in the evidence lockup and take a closer look at it.
- 303 Enter the bulldozer. Take all.
- 304 Give the Talisman to the magician (the first letters of the words in the mantra recited by the magician form the phrase: POUR WATER ON THE LAMP. Don't wait for the magician to finish reciting it). Pour water on the lamp. Rub the lamp. Tell the genie to kill the magician. Yes. Take the lamp.
- 305 Look in the trash bin. Take the hammer.

- 306 Look at the statue through the telescope. Show the ruby to the pigeon. Tell the pigeon to get the ruby. Drop the pigeon.
- 307 Eat the pearl blossom. Ask about the blossom. Take the stick.
- 308 Take key.
- 309 Take the leaf. Pour water on the lava. Immediately go west after you pour the water on the lava.
- 310 Buy the rope. Offer 10 (continue to increase your offer in increments of 3 coins until Hosni accepts).
- 311 Buy the ticket.
- 312 Cast glow. Cast fly on me.
- 313 Sleep.
- 314 Examine the flowers. Wait (repeat until the Mayor of Froom appears and offers you the choice of a key to the Kingdom of Froom). Take the XXX key (where "XXX" is the color of the rags on the 3rd scarecrow).
- 315 Climb the tree. Inch along the fallen tree trunk until you are across the fissure.
- 316 Open the cupboard. Take the poison and the jar.
- 317 Drink water.
- 318 Give the slippery fish to Smeagol. (Smeagol will now once again follow you).
- 319 Sit down. Read the screen. Place palms on screen. Press the pad. Read the screen. (Repeat the last two commands until you have learned all five koans). Take the card.
- 320 Sit on the carpet. Fly the carpet.
- 321 Sell the crown and the doubloon. Ask the woman about the staff. Ask the woman about the stick (you found in the cellar). If either is the implement of Annihilation, your search is over. Return to the kitchen. Otherwise continue your search (perhaps in the Forest). I shall assume that you have found it at this point as I did.
- 322 After you get the warning that you have only five minutes of air left, move to the rear right and: Open chamber. Enter chamber.
- 323 Give the keg to Jacque.
- 324 Throw key. Swim river.
- 325 Answer yes to Queen Guenever's question concerning Sir Lancelot having given you something for her. Give the medallion to the Queen. Take the dagger (note that the dagert has been forged by herself).
- 326 Say 'free beer for all'.
- 327 Approach the counter (take note of the password given to you by the proprietor)
- 328 Pull the lever.

- 329 Answer yes to the peasant's request for help.
- 330 Ask Sherman for the pigeon.
- 331 Before coming here, make sure you hear the gatekeeper shout "the rat race will start soon". Examine the rats. Bet on the grey rat (he wins and you are payed off by cheque). Take the cage.
- 332 Take the yellow paper then put it on the tomb. Rub the yellow paper with the crayon. Take the yellow paper.
- 333 Take the axe. Fly.
- 334 Buy i.d.
- 335 Open the cabinet. Take the key.
- 336 Hide behind the door. Wait (repeat until Topaz bursts into the room and kills the sniper). Hit Topaz.
- 337 Drop the mirror, keys, and bone. Take the pick.
- 338 Read the pamphlet.
- 339 Take the phaser and the communicator and the tricorder (Spock will take the tricorder from you). Get on the transporter. Energize.
- 340 Put the coin in the slot.
- 341 Knock on the door on the right. When asked for the password, type: Ken sent me.
- 342 Cast glow (use this spell sparingly since it will eventually wear out).
- 343 Throw ring in fire (you have learned the "exorcise" spell).
- 344 (Assuming you encounter the green knight). Kill the horse with the spear. Take the reins.
- 345 Wave the tablecloth (at the bull). Drop the tablecloth.
- 346 Open the book to page vii. Follow the directions to perform the "Teleportation at Random Spell". Do the same for the "Brewing a Storm" spell and the "Becoming Invisible" spell.
- 347 Take boots. Take pendant.
- 348 Take the bones. Give the bones to the ghost (If the ghost leaves, follow it and when it eventually returns here it will take the bones from you at which time they will form themselves into the word "slow". You have learned the "slow" spell. The "slow" spell can be cast at the mouse to learn the "death" spell. Thus, reading the black book at the lake (which also teaches the "death" spell) can be saved for another spell later on in the game).
- 349 Step up to the counter and buy a condom. Take the magazine (from the magazine rack). Pay the clerk. Take the wine (from the shelf on the rear wall).
- 350 Pray. Search. Examine plates.

- 351 Open the jar.
- 352 Take the brown paper then put it on the tomb. Rub the brown paper with the crayon. Take the brown paper.
- 353 Put the saddle on the unicorn. Mount the unicorn. Doofer the unicorn.
- 354 Open the box.
- 355 Open the safe. Put the gem in the safe. Close the safe.
- 356 Climb the tree (assuming there are no orcs present. If orcs are here, you must leave and then come back here along a different path). Sam "climb the tree". Wait (until an orc (say the wimpy one) enters). Sam "jump the wimpy orc". Wait (until the other orc enters). Jump on the skinny orc. Sam "attack the wimpy orc". Attack the skinny orc. Sam "take the orcish clothes". Sam "wear the orcish clothes". Take the hair shirt and the fishing-line. Wear the hair shirt.
- 357 Climb log. When you get halfway across: Tie rope to log. Climb rope.
- 358 Cut the fruit with the knife. Take the fruit. Eat the fruit.
- 359 (The puzzle associated with discovering the secret passage has three parts). Move the treatise. Take the hat. Press St. Sinistra (the portrait pops open revealing the passage).
- 360 Take the tarpaulin. Take all.
- 361 Take the trash can. Put the trash can under the ladder. Stand on the can.
- 362 Wait (for some human character to show up here). Then go south.
- 363 Wear the hat.
- 364 Just sit back and watch the shootout and then the finale.
- 365 Outside the cave, rub ointment on body (making yourself invisible).
- 366 Take the pot. Take the key.
- 367 Break the coal. Take the fossil.
- 368 Eat carrot.
- 369 Drop all but the walrus charm.
- 370 SPEAK to the clerk. Say: "Thomas S. Bondwell". Take the box and OPEN it.
- 371 Put the magnet (shaped exactly like one of the elevator buttons) in the space above the button corresponding to the 4th floor. The elevator will rise to the 5th floor and open. Before exiting, take the magnet with you else it might be missing when you return.
- 372 Put the blue key in the diamond slot. Drop the mug in the lab on the way out.
- 373 Take the red die.
- 374 Ask the officer for form 22Z-131.

- 375 Answer: your choice to your newly acquired wife's question concerning when you want her to be beautiful (she gives you a very important piece of information concerning which piece to move when you encounter the Deadly Chessboard. This piece will change each time you play the game). If you have not already done so, make sure that you pray in the chapel before you leave this area of the game. You must pray in every possible place of worship in order to be able to complete the game.
- 376 Take the horse barding.
- 377 When Laura leaves: Take the clipboard (from the left wall). Turn the pages until you come to the FBI Most-Wanted List. Take the poster. Return the clipboard. Take the keys (to the undercover car from the left wall). Walk over to the file cabinet and: Open the cabinet. Read the Hoffman file. Take the Hoffman file.
- 378 Examine the directory (pay particular attention to which apartments are vacant on the 3rd, 4th, and 5th floors. Now correlate this information with that corresponding to which windows are open. Keep in mind that standing in Ostnitz Square, you are looking at the east side of the building, i.e., apartments B, D, and F).
- 379 Wait (twice. The water is up to your nose). Up.
- 380 Upon entering, the robot will start after you. Immediately reverse directions and head back in the direction you came. Go all the way across the fortress (11 rooms) until you are back here again. The robot will follow you until you pass through the flashing circular door. At that point the robot will stop following you and head back for the escape pods; but, you will win the foot race. Approach one of the pods and: Push button. Enter pod. Push launch button.
- 381 Just wait for Morgan to give you your instructions.
- 382 Open the door. Release the brake.
- 383 Wait out the storm while the farm house rises into the air and soars high above the Fields of Frotzen eventually crashing to the ground in the land of Froom.
- 384 Open chest. Look chest. Take pillow. Take blanket. Move chest. Take bag (of ashes).
- 385 Dial 300.
- 386 Give form 22Z-13I to the officer.
- 387 Take the chest.
- 388 Take the parchment.
- 389 Do not turn on the lantern. Recall what the platypus did with the jar. Open the jar. Take the circlet. Dip the circlet in the jar then blow into the circlet (the bubble that emerges from the circlet forms into a mirror. You want to use the mirror to reflect light into the direction you want to go). To determine the direction to which you should point the mirror, recall the basic principle of physics, namely, the angle of incidence equals the angle of reflection. Thus, in this room, since light enters from

the southeast and you want to go southwest: point the mirror south. Continue to do this as you wind your way through the underground rooms, i.e., set up a continuous path of light from the entrance all the way to the Treasure Chamber. Along the way you will encounter a junction of underground rooms which requires you to make a decision as to which way to head. There is no way of telling which is correct, so just hope you are lucky. It's a good idea to save the game here. Since the mirrors (being bubbles in reality) will pop after a finite time, be very efficient with your moves. If the first one (nearest the entrance) pops before you get to your final destination, you are out of luck. You then must go back and start blowing mirrors all over again.

- 390 Approach the table and: Write Memo. Put memo in basket.
- 391 Jump into the lava.
- 392 Take the cigar ring (that's lying on the carpet). Take the train schedule (from on top of the dresser).
- 393 Wait (until until two of the three enemy guards from the automobile are in quiet conversation with the owner of the hut. Then immediately go around to the back of the hut and enter it).
- 394 Take the keyring. Wait (repeat until you are handed a document). Read the document. Drop the ticket and the document. Open the gate.
- 395 Move around to the left side of the bed and type: strip. Wear the condom. Get in the bed. At the end of the sex act, type: remove the condom.
- 396 Take the birdseed.
- 397 Hide all. Take the porridge. Assuming it is almost 25 minutes from the time the wizard went to sleep or on his journey, go down to the hallway and wait for him to reappear and tell you he's ready to eat.
- 398 Play. Steal the tokens. Steal the bear.
- 399 Approach the bard and: order a drink. Beer. After Woody brings you and Sweet Cheeks your drinks at the table: Pay Woody. After you tell Woody about your recent activities, you need to get him to "open up". Stand up, walk to the bar and: Give money to Woody (you slip him a twenty).
- 400 Hit the pinata with the club. Show the card to Parti. Hit the pinata with the club.
- 401 Nothing to do here other than get the blue key from the barker.
- 402 Shake the potion of Enlightenment. Drink the potion of Enlightenment. Wear the helmet. Open the reliquary. Take the white hemisphere. Join the black hemisphere to the white hemisphere. Look inside the sphere (you see a warlock standing before a wall of stone. He mutters a secret word. If you hadn't consumed the potion of Enlightenment you wouldn't have had enough intelligence to see what you just did inside the sphere). Say the word: XXX where "XXX" stands for the word you just saw in the sphere. An outline of a door should appear in the wall. Open the door.

You are on your way to meet the Ur-grue. From this point on, all you will need is the horseshoe, clover, rabbit's foot, jar, and the lantern. So, drop everything else.

- 403 Cast glow. Close the door. Take the note. Read the note (you have learned the "grow" spell). Cast grow on marrow. Read marrow (you have learned the "cure" spell).
- 404 Take the clothes.
- 405 Drop the small crate. Jump on the small crate. Jump on the large crate. Jump to the ladder. Climb the ladder (2 points).
- 406 Take the mat (from under it falls a key). Take the key. Tie the halyard to the reins. Tie the rope to the roller.
- 407 Drop the stool. Put the ladder on the girder. Take all but ladder and stool. Climb on the stool. Climb the ladder.
- 408 Show the ruby to Holmes. Give the emerald and the ruby and the opal and the sapphire to the guard. Give the shilling to Wiggins. Ask Wiggins to steal the keys.
- 409 Before casting the glow spell, go east and read the writing (you have learned the "cold" spell).
- 410 Ask the cook about the onion. Take the onion (you learn what you can give the cook to get it). Open the door.
- 411 Take the club.
- 412 Take the bowl, cleaver, and knife. Examine bowl. Take the sugar. Search. Take the bread.
- 413 Take the hat.
- 414 Take the lamp and the magnifying glass and the ampoule.
- 415 Answer no to Cador's sister request for your hand in marriage. (You already made the hag a promise. Nevertheless, Cador's sister will give you an important piece of information that you will need in the Chapel Perilous). Pray.
- 416 Wait (for Lucy to offer you a garter). Take the garter.
- 417 Put the table on the quicksand.
- 418 Look at the watch. Type: C. Climb up the wall, onto the ceiling and into the red port.
- 419 Open the library book. Take the ticket. Give the big burger to the dog.
- 420 (Your path to the west is blocked by a vague outline). Examine the vague outline (that you found in the chest). It's now a phase blade. Cut the outline with the phase blade.
- 421 Open the locker (in the 2nd row and nearest to the bench). Take all. Open the briefcase. Take all. Close the briefcase. Close the locker.
- 422 Lift the flap.

- 423 Throw the rag over the gate.
- 424 (Make sure the dragon and troll are with you). Troll, wait 2, kill the ants. Dragon, wait 1, kill the ants. Kill the ants. Take the amber. Examine the amber (you have learned the "magician" spell).
- 425 Step out from under the arch. Since you have used up your three rides on the pterodactyl, the easiest way out of here is: point the implement of Sayonara at myself (take the minx with you). Go to the Magick Shoppe and have the woman identify which of your potions is the potion of Enlightenment.
- 426 Wait (repeat until the gondola arrives at the loading dock and all the passengers get off). Enter the gondola. Wait (as the gondola drifts off into the jungle. When it is gliding just a few feet from the top of the first support tower you come to then: exit the gondola).
- 427 Take the candy (from on the table). Climb through the window.
- 428 Shout "stop the windmill".
- 429 (This a good place to save the game). Look inside the bowl. Take the Talisman. Put 42 gold coins in the bowl. Now, exit the statue as quickly as possible.
- 430 OPERATE a quarter on the blind man and then take a newspaper.
- 431 Move the cheese with the twig. Take the cheese. Eat the cheese.
- 432 (There should be a boat here now. If you had come here before entering the Chapel Perilous, you wouldn't have found the boat). Examine the boat. Drop the armor, helmet, and shield. Enter the boat.
- 433 Take the two-ferg coin.
- 434 When the barriers start moving toward you type: attach plunger to barrier (but don't press the RETURN key until the acid pool is almost touching your feet). Walk under a sprinkler. Put toilet paper in basket. Drop basket. Light toilet paper (with lighter).
- 435 Approach the suit on the left of the rear wall and: Change suits. Search your suit. Open the locker. Take all.
- 436 Turn the faucet. Turn the handle. Turn the wheel.
- 437 When you meet the abominable snowman, type: dip the fly wings in the essence. (The abominable snowman will be confused by this and head back to his cave).
- 438 Ask officer about form 69B-12C. He tells you he wants form 43A-81G from E4L-C. When you get there he will want form 11X-16B and form 51M-970. Continue this rat race until you eventually get to room S4R-E.
- 439 Give money to brother. Open chest. Get gun.
- 440 Troll, wait 1, pull the rope out of the water. Pull the rope out of the water. Take the ring.
- 441 Put the ladder on the shop. Take the ladder.

- 442 Tell the librarian to be quiet. Open the old book then read it.
- 443 Push the power button. Turn dial. Push thruster button. Pull throttle (the shuttle takes off). Eventually you will leave the planet. Shortly after that Vohaul will take control of your ship and guide you to his fortress on the asteroid.
- 444 OPERATE baggage claim ticket on the attendant. Take the suitcase and OPEN it. OPEN the clothes. OPEN the letter and EXAMINE it.
- 445 Open the drawer. Take the grotty key.
- 446 Take the blanket.
- 447 OPEN the front door of the laundry. Then go back downstairs and hide in the dumpster. Eventually, Moose and Spike show up and seeing that the front door of the laundry is open, figure that you escaped. They then leave.
- 448 While the lava is still hot (before it turns into a hard crust): inscribe the glyph on the lava. Wait (while Cardinal Toolbox congratulates you and eventually asks what you would like for a reward). Ask the cardinal for the reliquary (he grudgingly surrenders it to you).
- 449 Pray (the woman thanks you for returning the relic).
- 450 Give the vase to the servant.
- 451 Take the pork. Wait (repeat until the current pulls you in towards the island and the cask lodges itself in the sand).
- 452 Read the small book to the cat.
- 453 Take the carnation then wear it. Wait (repeat until your contact bumps into you and utters the phrase (in Frobniian) that the American spy told you about at the beginning of the game). Say "popka izim". Drop the film. Wait.
- 454 Enter the bowl. Put the tarpaulin on the bowl.
- 455 Turn on the flashlight (to map the sewer maze, you can mark the walls in the rooms (but not the intersections) with the chalk. For example, a suitable command might be: write "1" on the wall).
- 456 Give the ticket to the man. Take the bust. Break the bust (repeat until you shatter it). Take the bundle. Read the bundle (this is the third set of documents hidden by Maria).
- 457 Take the black hemisphere (from among the chemicals on the workbench).
- 458 You meet up with the Fool. Wait (until the Fool tells you that what you seek can be found at the desert's edge).
- 459 Take the radio extender (from the table). Take the keys (hanging on the left wall).
- 460 Touch the key (you are fried and then asked if you would like to be fried again. Respond: yes. You wind up floating in a bubble).
- 461 Fill vial. Ring chime.

- 462 After you pull over the drunk driver, approach his car and tell him to: Get out. Smell breath. Give FST. Handcuff man. When he asks to be handcuffed in front say: No. Read rights. Follow me. Put the drunk in the back seat of your patrol car. Radio headquarters.
- 463 Take the dagger.
- 464 Take the gloves.
- 465 (There are four possible endings to the game starting at this location. Only one set of hints will be given here. To see the other possible solutions, consult the complete solve for this game). Take the stone. Put the stone in the garter. Yes (when Lafond asks if you will come to him if he wins the duel with Jamison). Wait (repeat until Crulley moves down the stairs). Sling the stone at Crulley.
- 466 Go around the green car and: Examine the man (twice). Approach the people standing around on the street. Talk to the people (one of them is excited and will give you some information). Go back to the patrol car and: radio headquarters (twice). Wait for Dooley and Hamilton to arrive and then leave.
- 467 Hit the large cage with the coconut. Give the coconut to the macaw.
- 468 Attack the baby (this sets the mother hungus in a rage as she charges you). Head for the idol's maw (as the mother hungus follows).
- 469 Rip the frock. Dip the rag in the water. Open the hatch.
- 470 Drag the ten dollar bill from your wallet to the opening in the change window. The cashier will exchange it for two five dollar chips.
- 471 Doofer the cloud.
- 472 Cut the web with the small sword. Take the small sword.
- 473 Drink the milk. Open the can of worms. Put the worms in the milk bottle. Open the fridge (the plastic bottle you put in their before now contains ice and some oil). Take the oil (in the can that previously contained the worms).
- 474 Put the mat on the hedge.
- 475 Try to go north twice (you will now be 20 ft. from the castle entrance. Remember you do not want to shed any blood). Kiss the brooch.
- 476 Buy the diamond (or any of the other trinkets). You are refused and offered the sale of a 24 carrot ring for 20 coins. Accept the offer and buy it.
- 477 Take the key (then leave immediately).
- 478 Take the tablet.
- 479 Talk to the villagers (repeat until a drunk tells you that he stashed a catalog behind the wall of the King's prison cell).
- 480 Take the powder horn and the key.
- 481 Enter the swamp.

- 482 Take the twig.
- 483 Talk to John about task.
- 484 Open the crate. Turn off the flashlight and drop it after you have left the sewer system. This is the only place you will need it again.
- 485 Knock out the bung with the mace. Ask Wiggins to get the garnet.
- 486 Stay toward the bottom of the screen to avoid the hovercraft with Vohaul's thugs.
- 487 Empty the chamber pot (on the floor beside the bed). Open the drawer (in the dresser in front of the mirror) — you get the wizard's magic hand mirror. Open the drawer (of the dresser on the right) — you get a vial of rose petal essence. Open the cabinet. Look inside the cabinet. Move the clothes — you find a scroll. Examine the scroll (it's a magic map). Look on the top of the closet (you find a brass key).
- 488 Take the leather coin purse (from on the table). It contains 8 gold coins. Examine the bin. Lift the lid. Look inside. (Had the bandits taken something from you, you would have found it in here).
- 489 Take the hat then take the ampoule. Take a deep breath. Open the ampoule. Untie Holmes. Tie Akbar. Tie Moriarty. Take the key and the Crown Jewels and the whistle. Unlock the door with the key.
- 490 Open the mailbox. Take the leaflet then read it (it turns into a parcel). Open the parcel (all traces of it disappear and you are left holding its contents - a burin). Attack and defeat the Snow Wight (the implement of Annihilation will work quite well). Take the snowflake (that lands at your feet with a plop).
- 491 Search. Take the cudgel.
- 492 Take the chest.
- 493 Talk to the princess.
- 494 Dance with the man (Lafond). Wait (until he invites you to sup with him).
- 495 Take the bottle and the mirror.
- 496 Stir the storm brew with finger. Brew of storm, churn it up! (Bolts of lightning strike the huge dragon thus killing it). Untie the girl. (You explain to Princess Rosella that you are her long-lost brother Prince Alexander).
- 497 Take armour and scabbard. Examine dagger (you have learned the "teleport" spell).
- 498 Wait for the thin man to go to the open area and enter the brown door. Then continue to wait until he comes out and enters the restroom. Continue to wait until he goes back into the room behind the brown door.
- 499 Get off the raft (Sam should follow suit). Smeagol "get off the raft". Drop all but the ring and the branch. Get on the raft (If Sam follows, tell him to "get off the raft". Go back to the other side of Northern Edge of Swamp and pick up the rest of your inventory).
- 500 Take second stave.

- 501 Take the rope.
- 502 OPERATE SELF on the clean wine bottle (the one in the middle on the right side of the rack).
- 503 Take the talisman.
- 504 (You want to give the man in the suede jacket that has been following you the slip). Turn off the flashlight (because you are at an intersection where the directions are marked, you can move to another location in the dark. Go north and turn on the flashlight. You will have succeeded in losing the guy in the suede jacket).
- 505 Use wand. Use blanket (to smother fire).
- 506 Examine the shelves. Approach the counter and buy the pouch, salt, fish oil, and lard. (These are ingredients needed to cast the magic spells). Examine the floor (there's a brown-spotted dog lying there). Pet the dog (you get a wad of dog fur — another needed ingredient).
- 507 Hide all. Take the map. Take the mirror.
- 508 Read the sign. (This is the name of the building where the rifles are hidden).
- 509 Wipe the blood stain with the towel. Throw the towel through the window. Wait (repeat until the man wearing the trench coat enters and asks if you have seen the American spy). No. Wait (repeat until the man in the trench coat returns with two guards). Take the toilet kit and the color film and the train ticket and the passport.
- 510 Wear the robe. Take the wires (they wind up in a coil below. Leave them there for now). Remove the robe. Drop the robe.
- 511 Take the tablecloth and put it in the case. Unlock the back door with the iron key.
- 512 Cast exorcise on driftwood. Read driftwood (you have learned the “fly” spell).
- 513 Open the safe. Put the ring, painting, fossil, plastic bag, and dress in the safe (you will have to do this in several moves). Close the safe. Drop the cue, cotton, and needle. Put the mirror and cage in the swag bag.
- 514 Take the towel. Turn on the faucet. Wet the towel then turn off the faucet.
- 515 Thingy (if the sun weatherman is at your end of the beam. Otherwise skip this command). Take the hat (from the rain weatherman). Climb on the beam.
- 516 Take the tobacco then put it in the pipe. Open the matchbook. Take the match then strike it. Light the pipe with the match. Drop the lamp.
- 517 Push the key with the brush (you get the red key). Drop the small book and the brush. Take the clock.
- 518 Take all from the case. Drop the case. Doodah. Get on the cloud.
- 519 Take the berries.
- 520 Open the door (you can do this since you have the ID card).

- 521 After Dooley tries to read you the memo but can't because because the Gremlin sprayed it with mace, go behind the desk and: Read the memo.
- 522 Order a glass of whiskey at the bar.
- 523 Cast knives at rope. Cast shield on me.
- 524 Wait (until Cookie shows up. Cookie asks if you know where to find the captain).
Yes.
- 525 Take the stick.
- 526 Attach the wires to the slab. Examine the slab. (You will see a codeword for security clearance. It is different each time you play the game).
- 527 Rub the leaf on the skin.
- 528 Take the chalk.
- 529 After the Oracle goes through his ceremony, he will give you an amber stone. (If you go to the pier, you will find that there is now a ship there).
- 530 Raise the phial.
- 531 Hit the drunk. Get the wine. Jump north. Jump.
- 532 Take the ornament (which falls on your head as you try to go west). Make sure you are holding the caterpillar otherwise the Christmas tree monsters will not let you cross the mountain trail.
- 533 Point to the key. Take the key.
- 534 Move the debris.
- 535 Show the sheets of paper to the thin man. Show the multiple page document to the thin man. Show the bundle of documents to the thin man. Hit Ramon with the crowbar (twice). Get on the forklift. Turn on the forklift. Move the pallet with the forklift. Turn off the forklift. Get off the forklift. Take all but the crowbar.
- 536 Take all.
- 537 Troll, catch the apple. Shake the tree. Examine the apple (you have learned the "empathy" spell). Cast fly on statue (it is flying). Examine the statue (you have learned the "shield" spell).
- 538 Examine the ball (repeat until Jannedor glances at the fireplace). Doofer the ball. Drop the ash. Wait (repeat until the claw of Jannedor appears). Put the bracelet on the claw.
- 539 Spin the rod. Put the blue gem on the rod. Spin the rod. Give the rod to the Fool.
- 540 Read the book. Yes (you learn the "death" spell). Wait for druid (When it arrives it will breathe on the lake making the water smooth so that you can now see the word "CHARISMA" in its depths. You have learned the "charisma" spell). Rainbird, tell me about the perch (you have learned the "locate" spell).

- 541 When Russ asks you if he can help, say: Give me the black book. Return book. Give me the weapon. (Note the serial number). Read the tag. Return weapon.
- 542 Wait (repeat until the minx digs up the dirty truffle and swallows it whole. In the hole is a helmet). Take the helmet.
- 543 Wear the gloves.
- 544 Bow (or kneel).
- 545 Cast fireball. Tell fireball to attack the scrolls.
- 546 Take the rapier. Stab Crulley with the rapier (twice). Close the trapdoor. Give the smelling salts to the captain. Unlock the manacles with the brooch.
- 547 Take the brooch. Dig in the sand (you find some boots). Wear the boots.
- 548 Put the salt on the slug (in whatever room it appears). I also found a bubble gum card in one of the rooms on this level.
- 549 Watch the guards. Wear the gloves. Cut the fence with the bolt-cutter. Bend back the fence.
- 550 Get plunger. Get toothbrush. Brush teeth.
- 551 Wake Xam. Tie the rope to the manacle. Take the match then light it. Light the candle with the match. Put the candle in the glass. Put the glass under the rope.
- 552 Approach the ocean and: Take water (in your cup).
- 553 Sam "give the rope to me". Tie the rope to the stump. Climb down the rope. Take the rope.
- 554 Examine the table — on it you find a book (entitled "The Sorcery of Old"), a mortar and pestle, a brazier holding charcoal, a flint, beakers, measuring cups, flasks, and stirrers. Examine the shelf — on it are jars of ingredients namely: Powdered Fishbone, Nightshade Juice, Mandrake Root Powder, Saffron, Toad Spittle, and Toadstool Powder. All of these ingredients are needed to perform the magic spells discussed in the book. Take them. Open the book to page ii. Follow the directions to perform the "Understanding the Language of Creatures" spell. Do the same for the "Flying Like an Eagle or a Fly" spell, "Causing a Deep Sleep" spell, and the "Transforming Another into a Cat" spell. This spell creates a magic cookie. Put the cookie into the porridge. Go upstairs to the study, pull the lever (closing the trap door), move the book (back in the bookshelf), and put the magic wand back in the cabinet.
- 555 Listen to Morgan's plan for you and Sweet Cheeks at the Hotel Delphoria.
- 556 Cast sword on button. Push button with broadsword.
- 557 You will usually encounter a hag here (you may have to move around a few moves before she appears). Answer yes to her request for you to grant her one wish. She will give you the answer to a riddle that you will need later on.
- 558 Break the tablet.

- 559 Open the safe. Put the china pot in the safe. Close the safe.
- 560 Take the lantern.
- 561 Take the sword.
- 562 Approach the spa and type: strip. Look at the woman (repeat until you figure out what Eve wants). Give the apple to Eve.
- 563 Turn on computer. The search string to enter into the computer is the serial number of the weapon.
- 564 Follow skinny man.
- 565 Take all.
- 566 Wait (repeat until thy rope is swinging toward the cave). Then, jump.
- 567 Chew gum. Drop bottle and cage. Shake bottle. Wait (the manager leads you out of his office).
- 568 Bargain with vendor (twice). Buy the telescope.
- 569 Take the wine. Look at Fawn. Get in bed. Cut the rope with the knife. Take the rope. Take a cab back to the bar (you might want to play some more blackjack and/or slots in the casino on the way down if you need some money for cab fare).
- 570 Hit the minerals with the pick. Drop the pick. Take the chips.
- 571 OPERATE the business card on Gabby.
- 572 After you pull over the driver in the red sports car: Open the briefcase. Take the ticket book. Take the pen. Close the briefcase. Exit your car and approach the driver. Examine the driver. Talk to the woman. She will ask for your name. Type: Sonny Bonds. She apologizes and offers to do anything for you in replacement for a ticket. Type: No. Write ticket. Return license. Ask woman to sign ticket. Give ticket to woman. Return to your car and radio headquarters.
- 573 Untie the yellow boat. Start the yellow boat (this prevents anyone from taking off after you and Maria). Get in the maroon boat. Untie the maroon boat. Start the maroon boat.
- 574 Move the abstract painting. Open the cabinet. Drop the cue.
- 575 Wear the visor. Take all.
- 576 Search the body (of the captor on the left). Take the keycard. Search the hovercraft. Push the button.
- 577 Immediately go between the rock and the large tree trunk and hide behind the latter. Remain hidden until a hovercraft with one of Vohaul's thugs appears. When it leaves, come out from hiding.
- 578 Wear mask (immediately upon entering).
- 579 Give the jacket to the sword smith.
- 580 Rest (a tower appears).

- 581 Examine the dial (repeat until the needle points to the "0" mark)
- 582 Cast grow on ball and chain.
- 583 Take the plastic bottle and put it in the case.
- 584 Go around to the front of the lifeboat and take the shovel.
- 585 Ask the woman about the vial (it contains holy water). Sell the jewel (it's worth 1000 zorkmids). Buy the hourglass (it costs 1000 zorkmids). Take the hourglass. You can sell off some other of your valuables if you wish, e.g., the silver ornament, the diamond, etc. Buy the rabbit's foot (it costs 5 zorkmids). Take the rabbit's foot. Head off for the forest area.
- 586 Take mud (along side of stream) with the spoon. Dip the eagle feather in the essence (you turn into an eagle). Fly into the spider web. You (the eagle) grab the spider in your beak. You then take it to the ocean and drop it there. Fly back to the cave and return to your own form. (If the spell hasn't worn off yet, then recite the appropriate verse).
- 587 Knock on the door. Throw the tin at the oil lamp (the room goes on fire).
- 588 Tie the rope to the spear. Throw the spear at the ring (you swing on the rope across the chasm. You have now completed Part I of the game).
- 589 You return the princess to the King and Queen.
- 590 Take the parka and work shoes.
- 591 Drop the chest (The weight of the chest will hold the drawbridge open after you leave).
- 592 Buy the tickets.
- 593 If the abominable snowman reappears, wait until he again goes back to his cave. Then type: Fly begone! Myself return! Walk to the south and to the left of the iceladen rock and on the next screen climb down the wall.
- 594 Buy flask. Offer 10 (that's the minimum offer he will accept). Offer 13 (continue to increase your offer in increments of 3 coins until Hosni accepts).
- 595 Fish. Get the tuna. Swim.
- 596 Squeeze the moss. Wait (until your finger itches). Look at the finger (your dexterity increases which will help you fight the discipline crab and also get the bottle of wine that is on top of the stack).
- 597 When you leave the casino (or when you entered it), you will be approached by a poor man (who emerges from behind the bush on the right) to buy an apple. Buy an apple. Call a cab and go to the disco.
- 598 Drop the cue, bag, lamp, and succulents.
- 599 Unlock the door with the iron key.
- 600 Give the brush to Weelomin (in return you get a wrinkled blue robe). Give the robe to Spock.

- 601 Take the cello case. Open the wardrobe. Wear the shoes. Look under the bed. Take the sock and put it in the case.
- 602 Give the card to Karni. Take the quiz. The questions and their answers are as follows: 1) Does the Milky Way have at least 10,000 galaxies? N. 2) Is the Milky Way a Galaxy containing almost 10,000 million stars? N. 3) Is a 3 Musketeers a Milky Way without carmel? Y. 4) Is the Milky Way 3.7 parsecs from Earth? N. 5) Is "Cow Tao" another way of saying 'milky way'? Y. 6) Is our solar system near the center of the Milky Way? N. Take the cubes. Put the cubes in the mug.
- 603 (You will need the implement of Eversion which is used to turn things inside out). Point the implement of Eversion at the mother hungus. (The undigested contents of the mother hungus' stomach fall to the ground INCLUDING THE JEWEL). Take the jewel. Point the implement of Levitation at the baby hungus (this gets the poor thing out of the quicksand).
- 604 Blow the whistle (the pterodactyl arrives. You can use the whistle two more times in the game to call the pterodactyl). Put the saddle on the pterodactyl. Climb on the pterodactyl. Up.
- 605 Stand on the square striped pad (on the bottom left of the screen). Enter the transporter tube.
- 606 Put the rat on the table (then wait for it to return). Take the rat.
- 607 Attack the rat (with the shillelagh). (Repeat this until you defeat it). Rest (until your endurance is back to normal). Take the scroll. (When you read it, there will be a word inscribed across the top, e.g., Blarn). Light the lantern.
- 608 Ask Sherman about the pigeon.
- 609 Take the camera. Drop the document then photograph it. Rewind the film. Open the camera. Remove the film from the camera. Take the old roll then put it in the camera. Close the camera. Put the camera and film in the camera bag. Open the window. Take the document then throw it through the window. Open the briefcase the open the toilet kit. Remove the carnation then put it in the toilet kit.
- 610 OPERATE the brass key on your mailbox (the one to the far right). Take your mail and OPEN the envelopes (Actually you only need look at the contents of the personal letter to you).
- 611 Put forked thing in crevice. Put strand on forked thing.
- 612 Take the torch.
- 613 Wear the parka. Remove the black shoes. Wear the work shoes.
- 614 Open the safe. Put the ruby, plectrum, and chalice in the safe. Close the safe.
- 615 Drop the organ (you will need it later on when you enter the Fields of Frotzen). Read the palimpsest. Say the word that you find on the palimpsest. You are transported to the Ethereal Plane of Atrii, Above Village.

- 616 Examine the body. Lift the blanket. Open the shirt. Cover the body. Return to your car and: Radio dispatch.
- 617 Drop the shoes, shirt, and trousers. Drop all. Wear the aqualung, mask, flippers, and suit.
- 618 Take the amulet (from Cador).
- 619 Drop the mat. Sit on the mat. Wear the handbook. Meditate on the robe. Remove the handbook. Take the robe. Stand up. Take the mat.
- 620 Close door.
- 621 Bow to the Emperor. Give the rock to the Emperor.
- 622 Nothing to do here except note that Bondwell's house has been burned down indicating a desire on somebody's part to destroy any evidence linking Bondwell with the mob.
- 623 Take the blue paper then put it on the tomb. Rub the blue paper with the crayon. Take the blue paper.
- 624 Look costume. Take vial.
- 625 Give ribbed sphere to Weelomin (he will give you an item in return. Trade with him until you get the forked thing).
- 626 Push button. Enter the closet. Look closet. Take the glass cutter.
- 627 Say "can I help you?"
- 628 Take the armor, helmet, and mace.
- 629 Open the safe. Put the statuette in the safe. Close the safe.
- 630 Take the pearl blossom.
- 631 Examine the panel (you have learned the "lightning" spell. Alternately, you could have read the black book and learned this spell).
- 632 Give the (poisoned) porridge to the wizard (the wizard is transformed into a cat). Now, using the magic map teleport to the forest.
- 633 Give form 51M-970 to the officer. Give form 11X-16B to the officer.
- 634 Break the window.
- 635 The answer to the Evil Knight's riddle was given to you by the hag in the forest. It is: their will. Now fight and defeat the Evil Knight. Make sure you "kiss cross" several times during the battle to heal your wounds. The sword you found in the Tower Armory is a good weapon to use here. Also make sure you are wearing the armor, helmet, and shield. After you win the fight, a key will appear. Take the key.
- 636 Attack and defeat the spider (in whatever room it appears). I also found a rod in one of the rooms on this level.

- 637 Take the slipper and the pipe and the newspaper. Read the newspaper to Holmes. Wait (for the visitor to come into the study). Wait (for the visitor to leave and Holmes to unlock the bedroom door).
- 638 Take the mirror.
- 639 Sit down (at the table where the girl is). Look at the girl. Talk to the girl (repeat until Fawn asks you for a present). Give the candy to Fawn. Give the ring to Fawn. Give the rose to Fawn. Dance with Fawn. At the end of the dance, when Fawn returns to the table, go back there and sit down. Look at Fawn. Talk to Fawn (she makes you a marriage proposal). Pay Fawn.
- 640 After you pull over the Cadillac, radio headquarters for backup. Wait in your car (with the door closed) until Cobb arrives. Wait until Cobb takes his position. Open the door. Get out. Stay behind the open car door while Cobb inches up on the other side of the car. Draw gun. Load gun with ammunition. Tell the punk to: Get out. Put your hands up. Lie down. Approach the suspect. When you get to him: Put gun in holster. Handcuff suspect. Tell the punk to: Stand up. Search suspect. Read rights. Follow me. Put suspect in the back seat of your car. Go over to Jack and: Look at gun. Give gun to Jack. Walk over to suspect's car and: Look at door (the open one on the driver's side). Search the car. Open the glove compartment. Look in glove compartment. Open the notebook. Examine driver's license. Close glove compartment. Walk around to the rear of the car and: Open trunk. Look in trunk. Close trunk. Take suspect to jail and book him on drugs.
- 641 Drink the liquid (in the vial).
- 642 OPERATE the gun on the downstairs door (thus blowing the lock away).
- 643 Give brother the gun.
- 644 Take the rug.
- 645 Nothing to do here except to EXAMINE the arrival and departure schedules of the trains which are hanging on the wall. Head for the appropriate track and take the next train out to Chicago.
- 646 Rub the horseshoe.
- 647 To defeat the snake you should use the cudgel you got in the east cell.
- 648 Show the communicator to Jharpe (he eventually gives it back to you along with a green gem).
- 649 Give the birdseed to the bird. Put the saddle on the bird. Climb on the bird.
- 650 Wait (repeat until it is 2:00 a.m., Monday morning). Ask the proprietor for Akbar. Swordfish (when asked for a password). Give the garnet to Akbar.
- 651 Take the fish.
- 652 Take the bottle.
- 653 On the other side of the root maze: Pick the berries.

- 654 Go to about 5 steps east of the palm tree (near the rock). Dig for treasure. (You find a treasure chest).
- 655 Mend spear (you now have the Holy Spear). Touch the Fisher King with the Holy Spear.
- 656 Cast jump east.
- 657 Nothing to do here except note the names of the key locations that you must find in the game.
- 658 Put gem in mouth (you need your hands free to climb in the tunnels).
- 659 Give the tokens to the kids.
- 660 Play the lyre (you are teleported back to the courtyard).
- 661 Take the oil painting.
- 662 Take the dagger (it is thrust into the wall as you try to go west). If you hang around here a few moves, the bandits will mention a mysterious helmet north of the River Phee. This will have meaning to you later on.
- 663 Dig garden. Take carrot.
- 664 Throw the knife at the drawbridge. Take the knife.
- 665 Answer yes to the hag's request for your hand in marriage. Kiss the bride (surprise she turns into a beautiful nude woman).
- 666 Rub succulents on feet.
- 667 Jump west.
- 668 Wait until you will hear the first mate shout, "Drop anchor, an' prepare to go ashore!" (Again, this may take some time to occur). You are now close enough to swim to shore.
- 669 Read the inscription (you have learned the "glow" spell).
- 670 Push the black button.
- 671 Wait for ghost. Follow ghost (it will eventually lead you through a secret opening into a secret room).
- 672 Examine the painting.
- 673 Take the rat.
- 674 Give the keys to the bartender. Give the wafer to the bartender.
- 675 Rub the amulet. Take the key. Unlock the door.
- 676 Open the fridge. Put the plastic bottle in the fridge. Close the fridge.
- 677 Remove the shoes.
- 678 Open the door with the grotty key. Open the cage.
- 679 Watchercallit the coin. Buy beer with the coin. Watchercallit the glass. Oojimy the fire. Take the ash.

- 680 Take the fish cake (it will fall to the ground when you bump into the street hawker as you attempt to go north). Eat the fish cake (your intelligence will go up a few moves later).
- 681 Twist the cork (on the bottle). Fill the bottle with water (the ship grows to full size). Enter the ship.
- 682 Jump well.
- 683 Garth offers to mind your horse for you, Answer yes. Give silver sovereign to Garth.
- 684 Lure the rabbit with the ring. Take the rabbit.
- 685 Spock, scan the boulders.
- 686 Break the bars.
- 687 Inside the jail, approach Sweet Cheeks in cell #1. When she says she'll do anything to get out, say: Help with hotel operation.
- 688 Give gold sovereign to Geoffrey (he gives you some important information about drinking water at a lake which is an illusion and having seen an image of a glass tower at a clearing).
- 689 Take the coin (from the notecase on the desk).
- 690 OPERATE the key (you found in the office desk) on the side door of the laundry.
- 691 Take the mouse trap. Take the can of worms. Take the bung (from inside the boat).
- 692 Open the locker. Take the towel. Time for another shower. After you're done: Open the locker. Take clothes (your patrol uniform again). Take all. Open the briefcase. Take all. Close the briefcase. Close the locker.
- 693 Open the drawer. Take the pin and the rod. Put the rod in the hole (in the box). Take the torch. Plug the torch in the outlet. Examine the meter (repeat many, many times until it is fully charged). Unplug the torch. Take the instructions.
- 694 Take the dollars.
- 695 Show the bread to the baker (he throws you out of the shop).
- 696 Doofer the unicorn. Take the saddle.
- 697 Take the desk ornament (shaped like a hummingbird). OPEN the desk. Take the ledger. OPEN the ledger and EXAMINE it. Head back to the elevator (take the magnet before you exit on the first floor; you will soon have to get up to the fifth floor again).
- 698 Before entering the swamp: Rub berries on self.
- 699 Untie the red balloon.
- 700 Drop the mat. Sit on the mat. Wear the handbook. Meditate on the jar. Put the blanket on the jar. Drop the handbook. Take the key. Drop the rock. Stand up. Take the blanket.

- 701 Give the rod to the trader. If he gives you the small sphere, then stop trading. Otherwise, keep trading items (except the yellow gem, the spheres, and the strand) with him until you get the small sphere.
- 702 Give violet sphere to Weelomin (in return he gives you a statue of an animal).
- 703 Put the Onyx rod in hole 1. Put the Pearl rod in hole 2. Put the Emerald rod in hole 3. Put the Nickel rod in hole 4. (Note that the first letters of each of the rods form the word OPEN). Push the button.
- 704 Approach the desk and look at the security guard. Talk to the woman (repeat until Faith asks you for a medical stimulant). Give the pills to Faith. Push the button.
- 705 Drop the jeans. Take the mug, clock, pillow, and bear.
- 706 Talk to Fawn. Turn on the radio (wait for the broadcast to be interrupted and you learn of a phone number to call for wine delivery).
- 707 Put the poison on the fish. Feed the fish to the bear. Open the cubic cage with the key. Take the chalice.
- 708 Sit down next to Jack. Talk to Jack. Wait for Keith to enter and tell you that Morgan wants you back in his office at the station.
- 709 OPERATE the rope around your wrists on the crate (to your left).
- 710 Take the doll. Inflate the doll. Use the doll (twice).
- 711 Read the amulet through the wine bottle (you see a word on it, e.g., Macuga). Up (the cellar slams shut). Say Macuga (or whatever word was written on the amulet. Your strength temporarily (for one move) increases to 99). Smash the door.
- 712 Make your way across the swamp (and toward the north) until you encounter a deep part of the swamp and start to swim. Take a breath.
- 713 Roll the onion east. (Continue to roll the onion e, n, s, w, u, or d as appropriate on your way up to the Lamp Room in the Lighthouse).
- 714 Look for PS 3511 I-912 t29 (these are call numbers of a book and correspond to the numbers and letters on the back of the note you found on Maria's corkboard).
- 715 (Before coming here, you might want to leave your possessions outside the park since you are likely to be robbed in the park). Untie the balloon. (Don't forget to pick up your possessions on the way out of the park).
- 716 (The walls in the rooms on the upper level of the underground pit change as you move from room to room. The ones on the lower level are fixed). Tell Abu to pull the lever (this stops the walls on the upper level from changing).
- 717 Enter the ride.
- 718 Give the fish to the cat. Take the skull.
- 719 Rub the lamp. Blow out the lamp. Talk to the magician. Yes.

- 720 When the Captain is not in his quarters, enter them. Open the chest. Take all.
(You may have to try this sequence of commands a few times without being caught.
Sometimes the Captain will come in and sit at his desk. Go to another screen and
come back. He will usually be gone).
- 721 Wait (until the duck pulls some of its feathers and feathers one of the nests). Take
the feathers. Put the feathers in the pillow. Close the pillow.
- 722 Jump north.
- 723 Put the laser in the projector.
- 724 Open the chest. Look inside the chest. Take the prism.
- 725 Enter the ride. Examine the milk.
- 726 Along the way you will encounter a Lucksucker which will appear three times in
three different forms, e.g., a stepladder, a number 13, an umbrella, etc. Each time it
appears, immediately hit it with any of the three lucky charms you brought along,
e.g., hit the umbrella with the horseshoe. This will send it away for a while.
- 727 Read the note (on the corkboard. It's the one that came in your game package. The
Spanish words are the days of the week. The letters next to these words will have
significance later on in the game. Also the letters and numbers on the back of the
note will be useful later on).
- 728 Get the lute. Put the plastic die and anticube in the pocket. Rub succulents on feet.
- 729 Hopefully the tide is low so that you cross the bridge to the west. If not you will
have to kill some time until it does.
- 730 You will usually meet a pilgrim here. Give copper sovereign to pilgrim.
- 731 (There should be a pterodactyl here hobbling around in circles). Take the rod (or
other implement) of Anesthesia. Point the rod at the pterodactyl (it closes its eyes
and starts to drowse). Take the arrow. Rub the limp weed on the wound. Take the
whistle. Wear the whistle.
- 732 You will use your rose (which is in reality a compass) to navigate you. What you
need is a tail wind in order to fly the pterodactyl. Thus, point the rose in the
opposite direction to that which you want to travel in, e.g., if you want to go
northeast, then type: point the rose sw. Head for the castle.
- 733 OPEN the desk. Take the small key. OPEN the box and take the small magnet.
- 734 Look inside the boat. Take the oar.
- 735 Examine the pictogram.
- 736 Take the ticket. Run after the train (twice).
- 737 Drop the log into the river.
- 738 Put the mynah bird in the cage. Close the cage. Say "hello".
- 739 Open the portrait.

- 740 Wear the stethoscope. Listen to the door. Turn the dial right (twice). Turn the dial left. Turn the dial right (twice).
- 741 After Frank enters his room, and before you do, radio your backups (with the transmitter pen).
- 742 Drop everything before crossing the evil bridge.
- 743 Empty the milk bottle on the dirt. Dig in the dirt (it reveals a passage east).
- 744 Attach the clips to the fence.
- 745 Cut the hair. Take the hair. Tie the hair to the rope.
- 746 Take the pillow. Open the pillow. Take the note. (Then read it and drop it).
- 747 Take the box. Open the box.
- 748 Take your seat and listen to the briefing. Write notes. At the end of the briefing, walk over to the pigeonholes and: Look in the pigeonhole. (You find a sealed envelope with a message advising you of an illegal gambling operation at the Hotel Delphoria). On the way out, pick up your radio extender and patrol car keys.
- 749 Cut the lock on XXX with the bolt cutter ("XXX" is the number of Maria's locker you found in the folder in the Dean's office). Open the locker. Open the textbook. Take the map and the hat. Read the map (the letters you found on the note on Maria's bulletin board are the first letters of the colors of the circles around the locations of the map). Wear the hat. Drop the bolt cutters. Take the envelope and open it. Read the sheets of paper (this is the second set of documents hidden by Maria). On your way out of the college, don't forget to take the pink envelope you left in the alley.
- 750 Take the rat pie and the knife and the sack.
- 751 Move the junk. Take the cube.
- 752 In order to get into the troll's lair, you must first lure the troll far enough away from this here. The way to lure the troll is to move away one location at a time, each time dropping a treasure thus allowing the troll to steal it. Continue to do this for about six or seven locations and save the game frequently. The problem you will encounter is that other characters show up and also steal treasure from you. Thus, it is best to keep the treasures hidden in your sack and take them out one at a time. Although it may seem impossible to accomplish, it can be done but you will have to try many times. Starting from the bridge, and referring to your treasures as A, B, C,...., the specific sequence goes something like this: Remove the A (from the sack). Wait 1 (repeat until the troll steals A from you). East. Remove the B. Wait 1. South.....When the troll is far enough away, remove and drop any remaining treasures including the glittering card. Run to bridge. Open the door (three times. Hopefully, the troll has not shown up else you must try again).
- 753 Kill the bandits.

- 754 Attack the crab (with the shillelagh). (Repeat until you defeat it). Take the crown. Examine the debris. Take the doubloon.
- 755 Unlock the door with the rusty key.
- 756 Answer the phone. Dial the telephone (2096836858). Dial the telephone (5558039). Ask for wine to be delivered to the honeymoon suite of the casino.
- 757 Talk to the shark. Buy the loan.
- 758 Open the door. Examine the jeans. Look inside the pocket. Take the plastic card.
- 759 (Make sure the troll, rainbird, and mouse are with you). Troll, open the hatch. Troll, put the mouse into the hatch (repeat until the mouse attacks the wires and the force field disappears).
- 760 Show the card to the teller.
- 761 Play poker. When you win enough, Frank will again congratulate you. When he asks if you're looking for work, say: Yes. When he asks if you would like to join him in his suite for a drink, say: Yes.
- 762 Move in front of the tv and type: use the remote control. Change the channel (repeat until you get to a sex-oriented show that is of interest to the pimp).
- 763 Tell the Tan Man about the rifles.
- 764 Go to the end of the rope (without falling off) and: Swing. Swing back and forth until the beast swipes at you three times. Then at the end of your swing (closest to the ledge), let go of the rope (Ctrl-Z).
- 765 Drop the sack.
- 766 Answer yes to the nun's request for help. Pray.
- 767 (There should be a dust bunny here lurking in the corner). Drop the rug. Rub feet on rug (twice). Touch the bunny (the zap of electricity transforms the dust bunny into a hard ring of particles). Take the ring. I also found a scroll here.
- 768 Take the flask. Give the stick to Krin.
- 769 Give the food to the man.
- 770 Take the dragon and put it in the case.
- 771 Wait (repeat until the battle between the black rider and the prince is over and the prince's stallion is hit by an arrow and falls into the trench). Take the truffle (out of the pack). Throw the truffle into the trench. Having been previously preserved in the pool of radiance, it will stay fresh for all time. (If the hourglass is running out of sand, turn it over).
- 772 Cast glow. Wait (for the dragon. Continue to wait until someone shows up and tries to sneak behind the dragon at which point the dragon will crush him (her). The dragon will then lumber forward to attack and will get bitten by the mouse).

- 773 Take the clover (you will find it at one of the Gray Fields of Frotzen). I also found a scroll in this area. There are three scarecrows in this area. Two of them stand in patches of dead corn. The third presides over a patch of flourishing corn. At the location of the third scarecrow, play the organ (A rainbow of dazzling spectra should fill the air. You may need to play the organ more than once for this to happen. Also, make sure you have seen all three scarecrows before playing the organ). Examine the (3rd) scarecrow (Note and remember the color of its rags; they will be lavender, puce, or mauve). Move around in this area until the butterfly comes to rest on the rim of the goblet (if it has not already done so). Eventually, a small farmhouse will fall out of the clouds. Immediately, go inside of it.
- 774 Go behind and to the left of the tree in the middle of the scene. Examine the tree. Take the mistletoe (hanging from the tree).
- 775 Untie the ladder.
- 776 Drop third stave (in the fountain). Read fountain.
- 777 Roll the dice (Lady Luck asks what number you desire). Five (4 times). Put the red die in the first slot, the green die in the second slot, the blue die in the third slot, and the yellow die in the fourth slot). Take the plastic die.
- 778 Wait for Oink. Take the helmet (from Oink. If he runs away, follow him and then take the helmet when you catch up with him).
- 779 Move the lever up.
- 780 Hide behind the bush in front of you. While hidden: Sling the rock at the guard (using the athletic supporter). Approach the door in the right support of the platform and: Put the keycard in the slot.
- 781 Put the yellow key in the triangular slot.
- 782 Give the box to Weelomin (in return he gives you an embroidered robe). Wear the embroidered robe.
- 783 Read the walls (repeat until you get the message: "The password is: 'Ken sent me'"). Take the diamond ring (from the sink).
- 784 Cast cold at mud. Dragon, wait 1, clean the plaque. Clean the plaque (you have learned the "fireball" spell).
- 785 Pull the lever.
- 786 Doc, release a kite. Drop the mat. Sit on the mat. Wear the handbook. Meditate on the tachyon. The pattern that you see in the book represents the numbers which when followed in sequence (starting with "1" at Race Course 5) guide you in the direction of the correct path through the race course to win the kite race. When you exit the race course (Outside Corral), Doc Gravity will offer you his glasses as a reward. Remove the handbook. Take the glasses and the mat.
- 787 Hold the brown paper over the candles. Turn over the brown paper. Repeat the previous two commands with the blue and yellow papers.

- 788 Take the bone. Open the chest. Take the heart.
- 789 Give the globe to the captain. Say "ready."
- 790 Wear spectacles. Take the cheese.
- 791 Kill the monster with the axe.
- 792 Look under the pew. Take the vial.
- 793 Stand on the toilet. Remove the ceiling tile.
- 794 Fill the flask with water.
- 795 Wait (repeat until Topaz spots you).
- 796 Shoot the ninja.
- 797 Wear the ring (that the dust bunny was transformed into).
- 798 Ask baker for job.
- 799 Look on the floor. Take the fly (you keep only its wings).
- 800 Look south. Close the door. Turn the wheel.
- 801 Open the locker. Take the towel. Close the locker. Go and take a shower. (Remember to turn off the water when you're through). Return to your locker. Open the locker. Take clothes (your civilian ones). Take keys (to your Corvette). Close locker.
- 802 Take the card (from the ashtray).
- 803 Attack and defeat the cruel puppet and the hellhound (use the implement of Annihilation on the hellhound as he is tough. A longsword that you can purchase in the weapon shop is good for the puppet).
- 804 You must immediately go north from here else Frodo will go northeast to the dower and die.
- 805 Move to the door of the cage and: Call the hunter (twice). When he nears the cage: Throw the spore. Search the hunter. Take the key. Unlock the door. Open the door. Take the rope (from the boulder just behind and to the left of the cage).
- 806 Give rations.
- 807 Insert the pin into the torch.
- 808 Open the refrigerator. Take the food.
- 809 Wait for dragon (if it is not already here). Give the scale to the dragon. Recruit dragon. Dragon, go to mud. Follow dragon.
- 810 Take the rod. Spock, analyze the rod.
- 811 Ask the clerk about form 69B-12C.
- 812 (Assuming Smeagol is here. If not, look at one of the nearby locations). Sam "hit Smeagol". Sam "tie Smeagol with the rope". Smeagol "no". Smeagol "promise". Untie Smeagol (he will now follow you).

- 813 Wait (repeat until a man comes out of the antique shop and disappears into the crowd).
- 814 Give the gold standard to the hermit. Hit the hermit. Take the belt. Tie the belt to the rope.
- 815 Drop the business card. Knock on the east door. Say "XXXX" (where "XXXX" is the password you got in the antique shop).
- 816 Exchange the rock with the key.
- 817 Note that the southeast corner of the room is obscured by a curious shadow. You want to point the beam of light in that direction. So note the direction you entered this room, blow a mirror, and point it in the appropriate direction. Meanwhile the shadow has been talking about how to destroy you. After you shine the light on the shadow, it turns into a feeble old man (the Ur-grue) who grabs you around the throat as you bend down to touch him. All of the compassion you have accrued during the game will be absorbed by the old man and he will eventually release you. Look inside the mound. Take the coconut (the ground trembles. You must get out of here as quickly as possible since an earthquake is about to occur. If the chain of light has been broken by a popped mirror, light the lantern). As you wind your way back through the underground you will not get all the way to the entrance before the earthquake occurs. Nevertheless, you are rescued by the old woman from the Magick Shoppe and the sailor. You have won the game achieving the highest rank: Level 8.
- 818 Drop the coin. Recruit the mouse. Mouse, stay here, wait 1, put coin in recess.
- 819 Read the inscription. Youth.
- 820 Take the wallet. Cast glow. Wait (until the troll shows up). When she tries to entice you to return her wallet, answer: No. Recruit the troll. Troll, follow me.
- 821 Take the statuette. Open the black door with the ebony key.
- 822 Examine the chicken. Talk to Dooley.
- 823 Get sandwich. Open dresser. Get pajamas. Wear pajamas. Enter bed (the dream begins).
- 824 Open the sarcophagus with the bone. Take the eye.
- 825 OPERATE the train schedule on Gabby.
- 826 Examine the ground (around the tree). Take the acorns. Examine the tree (it has a small hole between its large roots). Reach inside the hole (a rope ladder appears). Climb the rope ladder.
- 827 Kill the spider with the beautiful sword (repeat until Sam kills the spider). Cut the cocoon with the small sword. Examine Frodo. Wear the ring. Wait (until the platoon of orcs pick up Frodo's body from the cocoon. Then, follow the orcs to the end of the game).
- 828 Pull the long lever.

- 829 Take the food (on the table) — mutton, bread, and fruit. Take the clay bowl (on the third shelf on the left). Take the knife and spoon (on the rack on the rear wall between the fireplace and the butter churn). When Mannanen asks for food, go to the Dining Room (he will be seated there) and give him the mutton, bread, or fruit.
- 830 Open the door (at the rear left of the shuttle).
- 831 Give the gum to Grajunk. Talk to hairy momma about the tonic.
- 832 Take the ladder.
- 833 Pry the manhole with the crowbar. Down. Look down. Say yes.
- 834 Drop the club and the card. Take the small book.
- 835 Take the knife and cloak. Wear the cloak.
- 836 Ask officer about form 69B-12C.
- 837 Give the strand to the trader. Give the robe to McCoy. Give the statue to the trader. Give the robe to Dimas. Give the forked thing to the the trader (in return you get a harrik brush).
- 838 There are two possible solutions to get past the crocodile. Hints for solution #1: Squeeze the drops (in the bottle) on the pork. Throw the pork at the crocodile. Wait (repeat until he falls asleep). Hints for solution #2: Throw the pork at the crocodile. Put the garter on the jaws.
- 839 Unlock the door with the key. Go north and find your father.
- 840 Find the frog. Kiss the frog. Look (you see a pebble). Examine the pebble (you have learned the “jump” spell).
- 841 Point the implement of Dispel at the dome (you start a volcanic eruption). Quickly head back to the Thriff. The lava won’t get that far but it will take care of the Christmas tree monsters on the way.
- 842 Cut glass (with glass cutter). Walk over to the vent and: Enter vent.
- 843 Take the stick (or other implement. You may find this in another room in the cellar).
- 844 Wait for the eagle to fly by and drop a feather. (You may have to go to another scene and then return a few times). Take the feather.
- 845 Pull on the rope. Jump to the boat.
- 846 Take the lamp.
- 847 Say Death to Colnar.
- 848 Wait (repeat until Gildea presents you with a red gem).
- 849 Give the bear to the princess. Get the rock.
- 850 Tell the Tan Man that the rifles are hidden in Spiney’s garage.
- 851 Put the pelican charm in the tin. Open the oven. Put the tin in the oven. Close the

- oven (hopefully the baker has not arrived yet. If he has, restore a previously saved game). Push the green button (twice). Open the oven. Take the tin (by now the baker should have arrived). Show the bread to the baker.
- 852 Take the gown. Remove the breeches and the shirt. Wear the gown.
- 853 Put the green key in the square slot.
- 854 It's your turn to move at the Deadly Chessboard. Type: XXX (where "XXX" is the chess piece your wife told you to move).
- 855 Examine the table. Take the porridge (in front of the baby bear's chair). If the three bowls of porridge are not on the table when you enter, go outside, open the door, and come in again.
- 856 Look in the stream. Take the fish.
- 857 Grok will take the rat pie from you and drop the map. Take the map.
- 858 Drop Bondwell's letter, Sugar Shack's letter, and the diary. These three items combined will indicate to Malone that he is being double-crossed by Ventini. Head for the train station on the double and take a train out of town. When you arrive at your destination, just sit back and watch the "Great Las Vegas Shootout" as Malone and Ventini are both eradicated.
- 859 Take the champagne bottle. Open the red bottle. Take the ruby.
- 860 Break mirror (with axe. You can now uniquely map the maze since the directions from room to room will be retraceable).
- 861 Examine the blocks (you want to arrange them so that the numbers in any row or column sum to 15). Slide 5. Slide 8. Slide 1. Slide 6. Slide 7. Slide 2. Slide 9. Slide 5. Slide 3. Slide 4. Take the bracelet. Put the charms on the bracelet.
- 862 Give the gold sphere to the trader (continue to trade with him until you get the ornamented rod). Put violet gem on the rod. Put yellow gem on the rod. Put red gem on the rod. Put green gem on the rod.
- 863 Say Death to Colnar.
- 864 Take the key. Open the south door. Kick the key south.
- 865 Take the scarab.
- 866 Open the safe. Put the brooch and chips in the safe. Close the safe.
- 867 Take the cue. Sit on the bed. Push the top button with the cue.
- 868 Type XXX (where "XXX" is the codeword you saw in the slab). Take the laser.
- 869 (If you like, before coming here, you can stop in the Weapon Shop and sell the sextant and bubble gum card to lighten your inventory and accumulate some zorkmids). Wait (repeat until the monkey grinder shows up. Continue to wait until the organ grinder snatches the warning nymph out of the air and crushes it in his fist). Give the chest to the monkey grinder. He opens it and the flash of light that

- bursts from its interior takes care of him. Take the organ.
- 870 Examine body. Swing Solomon's sword. Take the medallion and the brooch.
- 871 Take the crowbar.
- 872 Take the driftwood (it's in reality a club or shillelagh).
- 873 Open the sewing box. Take the needle and cotton. Open the wardrobe. Take the dress.
- 874 Swim.
- 875 Drop the aqualung, mask, flippers, and suit. Wear the shoes, shirt, trousers, and gloves. Take the case, paddle, match box, candle, mouse, amethyst charm, and walrus charm (from the parcel).
- 876 Break the tree with the sword. Take the branch. Lever the stump over the cliff with the branch.
- 877 Look under the bed. Take the china pot.
- 878 Examine the mouse trap (there should be a mouse in it now). Take the mouse.
- 879 EXAMINE the dealer. OPERATE the faded newspaper clipping (from your wallet) on the dealer. He will recognize you and swing the odds (i.e., cheat) so that you can win. Play blackjack until Rudy thinks the boss is getting suspicious. He will leave and be replaced by another dealer. DO NOT CONTINUE TO PLAY. Take your winnings and scam.
- 880 Ask twins for gum. Ask bartender about keg. Get jacket.
- 881 Drop all but the ring. Sam "drop all".
- 882 Wait (until the lizard drops a gold sphere on the ground). Take the sphere.
- 883 Attack and defeat the eldritch vapor and guttersnipe (in whatever rooms they appear). I also found a staff, scroll, and potion in this area.
- 884 OPEN the desk. OPEN the ledger and EXAMINE it. You will also find the things that the thugs stole from you before. Take them and leave the cigar ring behind so that Ventini will think Stogie was here indicating that Malone is on to him.
- 885 Take the hawser and bucket.
- 886 Put on the suit of armour.
- 887 Give the rice to Sushi.
- 888 Propose to the girl. Say 'free beer for all'.
- 889 Take the cotton balls (from the blue bottle). Put the cotton balls in the ears. Wait (until Big Ben sounds on the next hour. Any hour other than 1:00 a.m. or 1:00 p.m. is fine). Take the sapphire (three times)
- 890 Use the rose as before to navigate you to: Over Ruins.

- 891 Take the yellow die.
- 892 Take the reed. Breathe through the reed.
- 893 Look bird head. Insert rod. Take gem.
- 894 Examine the garden. Examine the flowers. Take the dew (it fills your thimble).
- 895 OPEN the penknife. OPERATE penknife on the lock (in the door). OPERATE the flashlight on itself and then go inside.
- 896 Wait for a human, e.g., Sam, to show up. Cast death on Sam. Give card to Sam (This is your way of getting the card into Paradise). Wait for Valkyrie (she takes Sam). Follow Valkyrie (to the glowing gate). Cast death on me (the Valkyrie takes you and drops you in the middle of a pink cloud. You should now see Sam).
- 897 Push the blue pad.
- 898 Get your towel and head for the shower. Turn on water. Bleach hair. Wet hair. Rinse hair. Turn off water. Get dressed (in the white suit).
- 899 After your three backup officers arrive, approach the one on the left and say: Give me the transmitter pen.
- 900 Answer yes to the woman's question. Take the cross.
- 901 Head back to the Magick Shoppe and check out (ask the woman about) the rod you found in the Lighthouse and the stave you found in the lobby. Then come back here and take the organ. Take the limp weed. Take the goblet (out of the pack). Holding the goblet will protect you from lightning as you travel the Fields of Frotzen. Turn the dial (on the organ) to the picture of an eye (if it is not already pointing that way).
- 902 Open the door with the ivory key.
- 903 Rainbird, in, push the button.
- 904 Feed the fig to the camel. Open the cylinder. Take the carpet (that you previously purchased).
- 905 Take the opener and put it in the case. Open the fridge. Take the bottle and put it in the case. Close the fridge.
- 906 Buy the big burger. Buy the junior burger.
- 907 Take the shield (you should be worthy enough by now. You will need this to fight and defeat the Evil Knight in Tintagel which is now where you are headed).
- 908 Examine the pictogram (it resembles what you previously saw on the obelisk and tablet). Take the strand. Set the phase to narrow beam. Fire the phaser at the hinge. Give all to Spock. Take the table.
- 909 Jump off the deck. You will land in the ocean very near the beach. Just swim to shore.
- 910 Light the lamp.

- 911 Hang around and listen to the mice (they offer a total of 4 messages) until you hear one of the pirates shout "Land ho, Captain". (This may take 5 to 10 minutes if you've been fast at regaining your possessions from the Captain's chest). Pour the sleep powder on the ground.
- 912 Wait (until Smeagol suggests going east. Without Smeagol in your party, it would not be possible to go east at this point in the game).
- 913 Before you leave the pool: Blow the whistle. Get out of the water. When the beast buzzes near you: Throw the puzzle (cubix rube). Walk to the opening in the boulder and: Take rock (from the debris on the ground).
- 914 Tie the cotton to the cue. Put the maggot on the needle. Hold the cue. Put the needle in the moat (you catch a fish). Untie the cue from the cotton. Drop the needle and the cotton.
- 915 Take the trousers and trenchcoat. OPERATE trousers and trenchcoat on self.
- 916 Take the incense burner.
- 917 Take the newspaper and read it. Put paper down. Find your place (at the left of the desk on the right nearest the podium), face front, and wait for the briefing from Dooley. Write notes. Walk over to the pigeonholes. Look in pigeonhole (nearest to the rear of the room).
- 918 Take axe.
- 919 If on the way here you met a floor waxer, retreat all the way back to the elevator, enter it, and wait for him to pass you. Then exit the elevator, and head back here. Push button (to the right of the door). Enter the closet. Look closet. Take the plunger.
- 920 Use the glowing gem (as you enter the dark cave).
- 921 Drop the hair shirt. Sam "drop the orcish clothes".
- 922 OPEN drawer #5. EXAMINE the tag on the toe of the stiff. Remember the name on it.

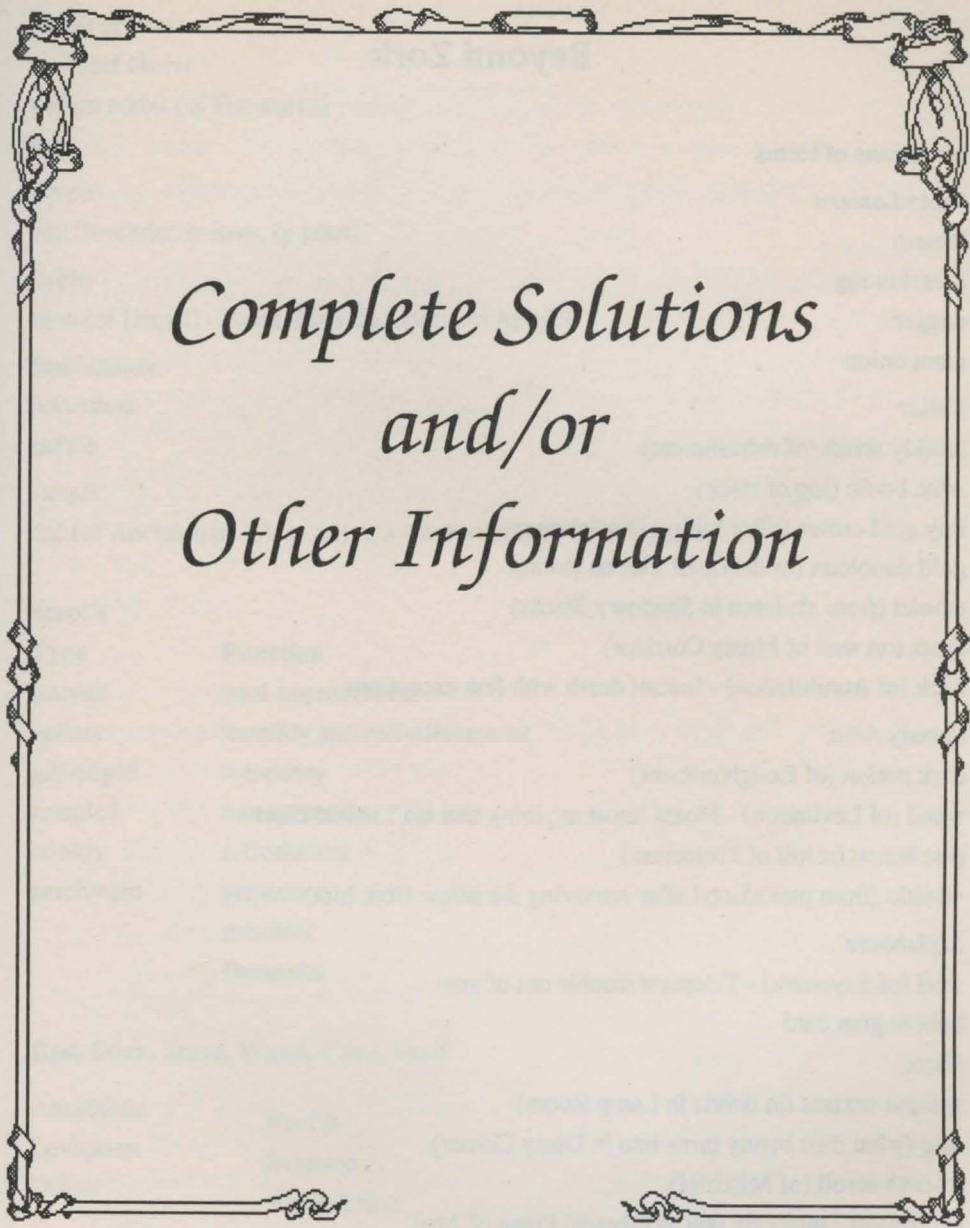

*Complete Solutions
and/or
Other Information*

Beyond Zork

Locations of Items

Rusty Lantern

lantern

bearskin rug

dagger

giant onion

Cellar

crinkly scroll (of refreshment)

wine bottle (top of stack)

tiny gold crown (after killing Discipline crab)

gold doubloon (in debris of Throne Room)

amulet (from skeleton in Shadowy Stacks)

moss (on wall of Musty Corridor)

stick (of Annihilation) - Instant death with few exceptions

Spooky Area

dark potion (of Enlightenment)

wand (of Levitation) - Floats 'most anything that isn't nailed down

parchment (scroll of Protection)

whistle (from pterodactyl after removing the arrow from him)

Lighthouse

staff (of Sayonara) - Teleports trouble out of you

bubble gum card

chest

antique sextant (in debris in Lamp Room)

ring (what dust bunny turns into in Dusty Corner)

smooth scroll (of Mischief)

palimpsest - teleports you to Ethereal Plane of Atrii

vague outline - becomes phase blade to cut outline in Ethereal Plane of Atrii

Forest Area

stave (of Eversion) - Makes things turn inside-out

Fields of Frotzen

four-leaf clover

vellum scroll (of Fireworks)

rose

Froon

key (lavender, mauve, or puce)

Lobby

cane (of Dispel) - Neutralizes the effects of Magick

Stablehouse

horseshoe

saddle

Jungle

rod (of Anesthesia) - Aim this at a creature and watch it stagger

Scrolls

Type	Function
smooth	yard improvement
vellum	humility and self-effacement
gilt-edged	weaponry
rumpled	transportation
crinkly	refreshment
parchment	protection
	mischief
	fireworks

Rod, Stick, Stave, Wand, Cane, Staff

Anesthesia	Vanish
Levitation	Eversion
Dispel	Annihilation

Potions

Type	Function
Dark	Enlightenment

Border Zone

The Train

You are an American businessman, travelling via train from the Eastern bloc country of Frobniya to neutral Litzenburg. An injured American spy asks you to deliver a top-secret document over the border. From that moment on, your destiny is uncertain....

take the camera	no
drop the document then photograph it	wait (repeat until the man in the trench coat
rewind the film	returns with two guards. They search
open the camera	through your things but fortunately
remove the film from the camera	leave the roll of color film containing
take the old roll then put it in the camera	the picture of the document and the
close the camera	toilet kit containing the carnation)
put the camera and film in the camera bag	take the toilet kit and the color film and the
open the briefcase	train ticket and the passport
open the toilet kit	e
remove the carnation then put it in the	s
toilet kit	s
open the window	take the carnation then wear it
take the document then throw it through	wait (repeat until your contact bumps into
the window	you and utters the phrase (in Frobniyan)
e	that the American spy told you about
s	at the beginning of the game)
w	say "popka izim" (which is Frobniyan for
take the towel	"It's my fault")
turn on the faucet	drop the film
wet the towel	wait (the contact will take the roll of color
turn off the faucet	film and disappear into the crowd -
e	Congratulations! you have completed
n	chapter 1 of the game. You happily
w	reboard the train for Vienna, wonder-
wipe the blood stain with the towel	ing what it was all about and what, if
throw the towel through the window	any, fruits your efforts have borne)
wait (repeat until the man wearing the	
trench coat enters and asks if you have	
seen the American spy that gave you	
the document)	

The Border

You are Topaz, the ambitious American spy. Moments ago, you escaped the KGB by jumping from a speeding train. But you are still in hostile Frobnia. Wounded and cold, you must survive and find your way to safety over the border. In the distance, you hear guard dogs approaching....

rip clothes (you wind up with a scrap of it
in your hands)

tie the scrap around the left arm (this forms
a tourniquet which stops the bleeding)

se

e

enter the swamp (your tracks and scent end
here thus getting the dogs temporarily
off your tail. Proceed through the
swamp and get to the north side of the
hut by the shortest route without
getting caught)

ne

n

ne

ne

w

nw

sw (outside the closed front door, two of
the three enemy guards from the
automobile are in quiet conversation
with the owner of the hut (Actually
they are warning him about an escaped
lunatic - YOU!!). Since he is tempo-
rarily distracted, go around to the back
of the hut and enter it)

e

open the door

w

take the parka and work shoes (now get out
immediately)

e

n

wear the parka (you will no longer be
cold)

remove the black shoes (you put them on
the ground)

wear the work shoes

n

w

enter the shed

look at the tools (now you know what
they are)

take the gloves and the bolt-cutter

leave the shed

ne

n

watch the lights (there is a searchlight on
top of each tower. The directions
that they point are now displayed on
the status line at the top of the screen.
When all three searchlights are
pointed away from you, immediately
go north. This action requires a bit of
hand and eye coordination as the
right and left lights move slowly, but
the center light moves rather quickly.
Also, the game does not immediately
respond when you type: "n")

n

watch the guards

wear the gloves (wait until the guards are
far enough away (you will have to
experiment with this) toward the right
and left towers and facing in their
direction)

cut the fence with the bolt-cutter
 bend back the fence (now you can get through it with getting killed)
 n (inside fence)
 examine the pen (surprise — it's an explosive)
 remove the cap
 push the button (about 4 times — the number of times you push the button depends on how quickly or slowly you move once you arm the device until you are at the place you want it to explode. You may have to experiment around with this until you succeed. Wait until the guards are far enough away toward the right and left towers and facing in their direction)
 n (center tower)
 examine the tower
 examine the posts
 replace the cap (this arms the explosive and starts the timer)

attach the pen to the ne (or nw) post
 u
 get on the brace (wait until the guards are far enough away toward the right and left towers and facing in their direction. Also, how long you have to wait here is tied to how many times you pushed the button. The entire procedure must be coordinated with the timer in the upper right corner of the screen)
 knock on the door (a guard comes out to see who's there)
 pull the guard's leg (this sends him head-first down the ladder)
 get off the brace
 enter the tower (if you have timed this properly, the guards will come after you. However, the pen will explode, the tower will fall over, and you will land in a small heap across the border. Congratulations! You have completed chapter 2 of the game)

The Assassination

You are a Soviet agent, rushing to complete a crucial task as the minutes count down to the assassination. Meanwhile, you have Topaz following your every move....

This chapter of the game is very dependent on the efficiency of your play since timing is extremely critical (The clock starts at 11:47 and the assassination is planned for shortly after noon). As such, it is almost impossible to complete in FAST mode. Play it in SLOW mode and you will have less of a problem. Even in this mode, you still must be efficient.

se
 look at the buildings (you will observe that three windows are open, one each on the 3rd, 4th, and 5th floors. Note the positions of these open windows, i.e.,

the south, middle, or north part of the building)
 w
 n
 w
 examine the directory (pay particular

attention to which apartments are vacant on the 3rd, 4th, and 5th floors. Now correlate this information with that corresponding to which windows are open. Keep in mind that when you looked at the building from Ostnitz Square, you were looking at the east side of it. Apartments B,D, and F are on the east side whereas A,C, and E are on the west side. Also, apartments A,B are at the north, E,F are at the south, and C,D are in the middle of the building).

e
se
sw
w

wait (repeat until a man comes out of the antique shop and disappears into the crowd)

s

approach the counter (the proprietor (your contact) will tell you the password. You wind up in the storage room)

w
n
e
e

n (Topaz is here sitting at a table. Wait until he spots you)

n

topple the cart (this will slow down Topaz for a few moves and takes you behind the cart)

w

take the trash can

put the trash can under the ladder stand on the can

u (Topaz should still be following you.

Continue to go "u" until you reach the fire escape on the floor that you determined the sniper was on)

n (continue to go "n" until you find the

location in the hallway (south, middle, or north) where the sniper's room is)

drop the business card (this will let Topaz know that you were here)

knock on the east door (a man asks you for the password. Respond to this order quickly)

say "XXXX" (where XXXX is the password given to you by your contact in the antique shop. You are escorted at gunpoint into the sniper's room who then closes and locks the door)

hide behind the door (so you don't get in the way of Topaz who will shortly come bursting through the door)

wait (repeat until Topaz bursts into the room and kills the sniper)

hit Topaz (you hit him over the back of the head with your pistol knocking him out cold. You have thwarted the assassination. Topaz made the kill. Viper barely escaped with his life. No bad publicity for the KBG. Congratulations! You have completed chapter 3 of the game)

Dark Lord

look at the mirror	s
enter the mirror	s
look at the floor	s
take the scarab	s
n	tie the rope to the tree
say hello	d
say yes	w
take the stick	w
w	n
s	look at the floor
look at the floor	take the flask
take the rat	give the stick to Krin (you learn that you must find a pearl blossom)
n	s
e	e
n	e
w	u
look in the stream	s
take the fish	w
w	w
n	w
n	look at the tree
n	take the pearl blossom
e	e
look at the floor	e
take the lamp	e
n	n
look at the dock	d
take the rope	w
w	w
s	n (back at Krin's home)
s	say hello
s	eat the pearl blossom (you feel a strange

surge of energy)	s
ask about the blossom (you learn that it has given you ability to fly. You also learn that the notes in your grandfather's journal that comes with the game will be of help)	s s s s e
take the stick	take the fish
s	w
e	n
e	n
u	n
s	n
w	n
w	fly
n	fly
n	land (on the shore of the island)
fly (you wind up in a shallow cave)	n
look at the floor	n
take the axe	d
fly (you wind up on a beach)	look at the hole
e	put the scarab in the hole (the door opens momentarily)
say hello	
ask the man for help (he tells you to stay away from the island)	n (you must do this immediately as soon as the door opens. If you don't, then take the scarab from the hole and try again)
say can I help you	
give the fish to the man (in return he offers you a scroll)	n
take the scroll	give the fish to the cat
read the scroll (it says: "though he believes he has beaten death, he is still a prisoner of it. For there is, yet, a way to defeat him...The signs of one's own mortality can be a destructive thing...)	take the skull
e	look at the skull (it contains a massive chunk of lead)
	w
	move the debris
	w (in a darkened passage)
	look at the floor

take the amulet

u

fly

fly

fill the flask with water

s

s

s

s

s

s

s

s

w

w

w

w

w (at a carved rock)

read the message

s

w

s

w

n

burn the plant with the lamp

w

w

n

n

look at the plant

take the leaf

pour water on the lava

w (you must do this immediately after you
pour the water on the lava to cool it)

rub the leaf on the skin

w

w

kill the monster with the axe (your passage
to the castle is now clear)

e

e

e

jump into the lava (you wind up back in
the foam of the modest stone house
lying in bed)

stand up

n

w

w

n

n

n

w

w

w

s

e

swim

w

w

w

w

n

n

n

rub the amulet

take the key

unlock the door (you wind up in a cell)

look at the torch

pull the torch

w

w

pry the stone with the stick

n

look at the opening

put the rat on the table (then wait for it to
return)

take the rat

s

e

n

w

look at the crystal

take the crystal

e

open the door

e

n

n

n

open the door

read the scroll

show the skull

throw the skull

Deja Vu II: Lost in Las Vegas

Bathroom

Take the trousers and trenchcoat. OPERATE trousers and trenchcoat on self. Open trousers. Open wallet (inside it is a quarter, a ten dollar bill, a one dollar bill, two newspaper clippings, and a driver's license). Examine the faded newspaper clipping (it shows you and Rudy Kowalski, an old sparring partner of yours. This will become significant in the casino). You will have to accumulate more money than you have to win the game. Time to head for the casino.

Bedroom

Take the cigar ring (that's lying on the carpet). Take the train schedule (from on top of the dresser).

Cashier's Room

Drag the ten dollar bill from your wallet to the opening in the change window. The cashier will exchange it for two five dollar chips. It's now up to you to win at blackjack starting with only these two chips. Forget about the quarter you have in your wallet. Don't bother to play the slot machines if you're trying to accumulate money. Just play them for fun if you want.

Blackjack Room

There are five blackjack rooms. In four of these rooms, if you play you will not be able to win consistently and build up your money. You need some inside help. In each room, examine the dealer. In one of the rooms, the dealer will be Rudy, your old sparring partner. OPERATE the newspaper clipping on the dealer. He will recognize you and swing the odds (i.e., cheat) so that you can win. Play blackjack until Rudy thinks the boss is getting suspicious. He will leave and be replaced by another dealer. DO NOT CONTINUE TO PLAY. Take your winnings and scam. (I was able to come away with \$75.00).

Baggage Claim Department

Nothing to do here except to EXAMINE the arrival and departure schedules of the trains which are hanging on the wall. Head for the appropriate track and take the next train out to Chicago.

Train

Obviously, pay the conductor by dragging the required amount of money (\$20) to him. Now OPERATE SELF on a seat, sit back and enjoy the train ride. When you wake up, you will be in Chicago.

Train Station (Chicago)

OPERATE a quarter on the blind man and then take a newspaper. EXAMINE the newspaper (you can do this without actually taking it but you will need the paper later on). Go outside and enter the cab.

Inside Cab

Since Gabby is deaf, you must show him something to tell him where you want to go. OPERATE your driver's license (from the wallet) on Gabby.

Hall (Inside Apartment Building)

OPERATE your key on apartment 1A and let yourself in to your apartment.

Your Apartment

OPEN the overcoat and take the .38 revolver, two quarters, and \$10 bill. Open the drawer (on the floor) and take the penknife, box (of bullets), safe deposit box key, and brass key. OPEN the gun. OPEN the box. Drag the bullets into the gun, i.e., load it. Also take the flashlight before leaving your apartment.

Hall

OPERATE the brass key on your mailbox (the one to the far right). Take your mail and OPEN the envelopes (Actually you only need look at the contents of the personal letter to you). Go back in the cab.

Taxi

OPERATE the newspaper clipping (with the address of Joe's Bar) on Gabby.

Fire Escape

OPERATE SELF on boarded up window.

Siegel's Office

OPEN telephone. Take the unusually shaped key.

Back Alley

OPEN the penknife. OPERATE penknife on the lock (in the door). OPERATE the flashlight on itself and then go inside.

Wine Cellar

Examine the wine bottles on the rack. All of them are dusty except for one in the middle on the right side of the rack. OPERATE SELF on the clean wine bottle (it opens up a secret passageway).

Casino

OPERATE the unusual shaped key (from the telephone in Siegel's office) on the slot machine on the right. OPEN the slot machine. Take the diary and business card. OPEN the diary and EXAMINE it. EXAMINE the card. Go back to Gabby's cab.

Taxi

OPERATE the business card on Gabby. He will take you to Sugar Shack's apartment.

Apartment Entryway

OPERATE the gun on the downstairs door (thus blowing the lock away).

Sugar's Apartment

OPEN the night table (Inside is a bunch of bank deposit slips bundled together with a rubber band). OPEN the slips and EXAMINE them. Notice that the dates are the same as those in the diary implying that Sugar was linked to Siegel in a pay-off operation. OPEN the wardrobe. OPEN the vacuum cleaner. OPERATE pocket knife on bag (inside vacuum cleaner). Take the envelope and OPEN it. Examine the letter (It is from Policeman McMurphy telling about his involvement in Siegel's illicit operation). Take the policeman's uniform (belonging to McMurphy). Remove the trousers and trenchcoat (OPERATE them on SELF). OPERATE the uniform on SELF. Go back to the cab and OPERATE the newspaper (you bought from the blind man in the train station) on Gabby. He will take you to the City Morgue.

Morgue

OPEN the gate. OPEN the door to the freezer at the rear of the room.

Freezer

OPEN drawer #5. EXAMINE the tag on the toe of the stiff. Remember the name on it: Thomas S. Bondwell. EXAMINE the body in this locker. Note the scar running through the stiff's left eye. Remember the middle man McMurphy referred to in the letter you found in Sugar's apartment? He also had a similar scar.

Morgue

SPEAK to the clerk. Say: "Thomas S. Bondwell". The clerk will give you a box containing his effects. Take the box and OPEN it (It contains two keys, a wristwatch, and a wallet). OPEN the wallet (The two things of interest in it are a baggage claim ticket with the number "526" on it and Bondwell's driver's license telling you where to go next. Get back in the taxi, get out of the uniform, and change back into your trousers and trenchcoat. OPERATE Bondwell's driver's license on Gabby.

Empty Lot

Nothing to do here except note that Bondwell's house has been burned down indicating a desire on somebody's part to destroy any evidence linking Bondwell with the mob. Go back in the cab and OPERATE the train schedule on Gabby. Time to take the next available train back to Las Vegas.

Baggage Claim Department

OPERATE baggage claim ticket on the attendant. He retrieves a suitcase from under the counter. Take the suitcase and OPEN it. Inside it is a pile of clothes. OPEN the clothes. Inside are a picture of Siegel shaking hands with a man whose initials are "D.V." and a letter. OPEN the letter and EXAMINE it. It's a letter from Bondwell to his boss telling about some strange happenings.

Corridor (3rd Floor of Casino)

OPEN dumpster. Enter the dumpster. CLOSE the lid (The dumpster will soon be loaded onto a truck and transported elsewhere. It is unloaded off the truck and deposited in a laundry room. The lid is flung open and two thugs (Moose and Spike) find you and tie you up. They also steal some of your possessions. You will find them later on and get them back. To untie yourself, OPERATE the rope around your wrists on the crate (to your left). Go upstairs to the hallway. OPEN the front door of the laundry. Then go back downstairs and hide in the dumpster. Eventually Moose and Spike show up and, seeing that the front door of the laundry is open, figure that you escaped. They then leave.

Hallway

OPEN the counter and then enter the office.

Office

OPEN the desk (Inside it is a box, a key, and a letter). OPEN the box and take the small magnet. Take the small key. Go back outside and into the casino again. OPERATE SELF on the button and enter the elevator.

Elevator

Put the magnet (shaped exactly like one of the elevator buttons) in the space above the button corresponding to the 4th floor. The elevator will rise to the 5th floor and open. This is where the offices of Anthony Malone and Dan Ventini (D.V.) are located. Before exiting, take the magnet with you else it might be missing when you return.

Malone's Office

EXAMINE the pictures on the wall. Note the close relationship between Malone and Ventini.

Ventini's Office

Take the desk ornament (shaped like a hummingbird). OPEN the desk. Take the ledger. OPEN the ledger and EXAMINE it. Note that its entries are quite similar to those found in the one in Joe's Bar except that the entries involving courier #0 are missing, i.e., Ventini has been doctoring the books. Head back to the elevator (take the magnet before you exit on the first floor; you will soon have to get up to the fifth floor again).

Laundry Entryway

OPERATE the key (you found in the office desk) on the side door of the laundry.

Office

OPERATE SELF on paperweight (found in Ventini's office. It separates into two parts one of which is a dart). OPERATE the dart on the dart board. A panel moves and a secret passageway is revealed.

Secret Office

OPEN the desk. Inside it is another ledger. OPEN the ledger and EXAMINE it. This one shows all the payments that appear in Siegel's diary, i.e., the *real* books. You will also find the things that the thugs stole from you before, in particular, the letter from Bondwell. Take them and leave the cigar ring behind so that Ventini will think Stogie was here indicating that Malone is on to him. You must now get Malone to turn on Ventini. Then, they will take care of each other and both of them will finally be off your back.

Malone's Office

Drop Bondwell's letter, Sugar Shack's letter, and the diary. These three items combined will indicate to Malone that he is being double-crossed by Ventini. Head for the train station on the double and take a train out of town. When you arrive at your destination, just sit back and watch the "Great Las Vegas Shootout" as Malone and Ventini are both eradicated.

Demon's Forge

The object of the game is to escape from the cave into which you have been banished by the King. For the most part, the game has a two word (verb-noun) parser for commands.

n	take gem
look costume	s
take vial	s
w	w
w	w
open chest	n
look chest	n
take pillow	e
take blanket	throw bag (on brazier. Joe the fire
move chest	elemental comes to your aid. Without
take bag (of ashes)	possession of the gem, you would be
e	torched by the fire)
e	w
e	n
e (a skinny man runs by)	n (with Joe's help, the doors go up in
follow skinny man (you go north to the	flames as you approach them. You are
junction route)	in a room with an assassin)
e (this is a secret room to which this is	kill assassin (he shoots you in the side with
ordinarily no entrance unless the	his poison arrow)
skinny man leads you there)	drink liquid (in the vial. You have
give rations (the skinny man downs the	neutralized the poison)
food and gives you a rod in return)	kill assassin (you are now able to kill him
w	easily)
n	search assassin (you find a chime)
look bird head	take chime
insert rod (in beak. The beak snaps shut	s
and a red gem rolls out onto the	s
ground)	

jump well (Joe evaporates the water. You	w
are at the bottom of the well and	n
it is slowly filling back up with water)	n
fill vial (with water)	
ring chime (the door opens and you fall	break mirror (with axe. Once you break
into the trick room)	the mirror, you can uniquely map the
	maze since the directions from room to
go left	room are now retraceable)
go right	drop axe
go right	e
go right (ignore the directions above the	n
doors)	w
go right	n (in the guardroom)
go right	w
n	dig garden (you find a carrot)
look rabbit (he looks like he could use a	take carrot
drink of water)	e
give water (you are asked "to what")	e
rabbit	climb ladder
take wand (forget the hat)	drop gem
e	drop wand
e	take boots
n	take pendant
use wand (you discharge the wand and a	look pendant (it says, "Dig where X's
flaming ball comes roaring out and	aren't")
melts the rubber door. Unfortunately,	d
the carpeting has caught on fire)	e
use blanket (it smothers the flames and	e
extinguishes the fire)	e
n	read 51 (it's a story of a man who wasted
take axe	his life away reading books in the library.
s	None of the other 77 books have
s	anything of interest. Actually,
w	to complete the game, you never have to
	"read 51" either)

w
n
n
take first stave (when you pick it up, it transforms into a shovel)
wear boots (you float up)
dig (digging on the ceiling with the shovel (believe it or not) drops a mound of dirt on the ground)
drop shovel
take dirt
w
w
open door
d
n
drop dirt (in hopper. You wind up back in the Room of Staves)
take second stave
w
w
d
w
burn second stave (with torch. You set it aglow. You again wind up back in the Room of Staves)
take third stave
w
w
d
s
drop pendant

get bottle
n
e
drop third stave (in the fountain. The murky water is now clear. Something is written on the bottom)
read fountain (it reads, "To avoid eternal strife you must give the breath of life. Do this deed first. Pay nothing else heed or these words may be the last that you read." You are back in the Room of Staves)
fill bottle (you are asked "with what". The breath of life, of course)
breath
take fourth stave (you may now leave through the east door but first you must drop the fourth stave)
drop fourth stave
e
drop pillow
n (the pillow cushions your fall)
n
e
move altar (a dark passage heading east is revealed)
e
s
read sign (your eyes are not good enough to see that far away. Maybe a carrot would improve your eyesight)

eat carrot (you can now read the sign. It reads, "Within the forge Anarakull goes. To test the mettle of his toes, to pit his claws against cold steel, spin wise the globes into a wheel. Of sword and spear—they harmeth not nor ageless cold or timeless rot. But balls of value shirk his hold when hurled with power ... slight to bold)

n

close door (a different passage is revealed)

n

take key

s

w

w

s

drop bottle

drop wand

drop vial

drop boots

drop key

w

w

take silver sphere

take gold sphere

take platinum sphere (now, remember the sign telling you to spin the globes into a wheel? What this meant was to.....)

juggle spheres (this is a key command since unless you do this there is now way to get all three spheres back across the bridge without it collapsing under you)

e

e

take key

n

n

n

throw key

swim river (you are now in an ancient crypt)

take key

unlock door

e (to kill the demon you must remember

the message on the sign telling you

hurl the spheres with power from slight

to bold. What this meant was to

throw the spheres at Anarakull in the

order of increasing value)

throw silver sphere

throw gold sphere

throw platinum sphere (you destroy

Anarakull. Congratulations! You have

returned from Demon's forge and have

required your freedom)

Dondra: A New Beginning

take the key (it's too hot; you drop it)	w (a wildebeest appears and blocks your
open the south door	way to the north - if you hadn't
kick the key south	ingested the liquid from the vial, he
s	would have killed you)
take the key (now, don't hang around here)	w
n	w
read the west door	n
read the north door (it's a sliding code	w
(shifted one letter) that says: "Speak	drop the vial
Ye These Words")	take the pot (the pot falls and breaks and a
say Death to Colnar (a keyhole appears in	key appears on the windowsill)
the north door)	take the key
open the north door (with the key)	open the door (with the key)
n (the skeleton will ask you to speak)	w
say Death to Colnar (you are given a sack	open the refrigerator
containing some items and then	take the food
teleported to the center of an arena)	drop the key
n	e
read the mural	e
s	e
w	examine the man
w	give the food to the man (in exchange, he
n (in a hut)	gives you a small knife)
take the cross (don't hang around here too	w
long else the owner of the cabin will	n
appear and shoot you)	examine the hole (it's a manhole - you
s	need something to pry it open with)
put the cross in the sack	n
examine the sack (it contains a vial, a gem,	examine the statue
and a cross)	read the plaque
examine the vial	e
drink the liquid	take the crowbar

w

s

examine the hole

pry the manhole with the crowbar

d

look down (a dainty voice from below asks
if you will indulge her senses)

say yes

d

nw

cut the fruit with the knife

drop the crowbar

take the fruit

eat the fruit (you wind up in one of four
(randomly selected) locations - in
front of a tiny tunnel, in front of a
scarecrow, in a cornfield, or in a
hollow barn. Go to the location with
the scarecrow)

take the hat (from the scarecrow)

w

look (those things with the letter "K" on
them are krona-dollars)

drop the knife

take the dollars

put the dollars in the sack

s

give the gem to the lioness

move the hay

take the rope

put the rope in the sack

n

e

e

wear the hat (you have been transformed
into a mouse small enough to get
through the tunnel)

e

nw

take the twig

n

move the cheese with the twig

take the cheese

eat the cheese (you are now back to normal
size)

n

enter the bulldozer (your other possessions
are here)

take all

leave the bulldozer (if you hang around too
long, you will be done away with)

e

turn the wheel

open the door

n

look south

close the door

turn the wheel (this locks the door)

n (if you hadn't locked the door behind
you, a manx guard would have come
out from the wooden door and killed
you)

open the door

n

drop the twig

take the ladder

examine the ladder

s

w
n
extend the ladder
put the ladder across the crevice
n
open the north door
n
open the drawer
take the pin and the rod
examine the box
put the rod in the hole (in the box)
drop the rod
take the torch
examine the torch
examine the meter
plug the torch in the outlet
examine the meter (repeat until the meter
reads full. Since this is a "timed"
event, wait about 20 seconds between
examinations.)
unplug the torch
take the instructions
s
read the instructions
insert the pin into the torch
e
n
pull the trigger (you fry both of the
mutoids - if the torch was not fully
charged, you would have only fried
one of the mutants and the other
would have killed you with a wrench)
search the mutants
s

w
drop the torch and the instructions
e
n
take the wrench and the keys
n
w
w
examine the panel
push the blue pad (since you have the keys
in your possession, the panel is
activated and a bridge extends from
the other side of the chasm)
w
drop the keys and the wrench
s
examine the south hole
enter the south hole
w
s
w
buy the clips
put the clips in the sack
w
n
look (you see a bird and some birdseed)
take the birdseed
n
sit on the pedestal (the robed man asks you
some questions)
say XXX (where "XXX" is the name of
the character that you assigned to
yourself at the beginning of the game)
say Death to Colnar

say teleportation (remember what the
lioness told you when you gave her
the gem - you can now safely cross
the bridge)

n

take the saddle

s

s

s

e

e

attach the clips to the fence

s

drop the saddle

n

w

n (you must now take the following set of
commands as quickly as possible
since you are being tracked by some
people and can be bumped over the
head at any time)

take the reed

breathe through the reed (you need to take
this breath to prevent you from
instinctively coming up for air once
you are underwater)

d (into the stream)

take the chest

u (you drag the chest out of the water. The
chest no longer glows)

open the chest

look inside the chest

take the prism

s

e

s (you are now safe from the people who
have been following you)

take the saddle

s

give the birdseed to the bird

put the saddle on the bird

climb on the bird (you fly over Dondra
with the crystal prism of Heheutotol in
your possession and return to the
location where you began your quest)

Dr. Dumont's Wild P.A.R.T.I.

s
take the jeans
wear the jeans
n
w
w
w
w
n
n
open the door
n
sit down (at the desk. Professor Parti
(spelled "Pardee" although the game
doesn't accept this word) appears in a
puff of smoke)
examine Parti (he is carrying a diploma. If
you try to take the diploma from him,
he tells you that you have to earn it)
examine the desk (it has a viewscreen, an
LCD button, and five keyslots, each
with a different shape)
read the screen (you are told that before
you can take your exam, you must
pass a DNA screening of your jeans)
place palms on screen (you pass the DNA
requirement and are now ready for
your exam)
press the pad
read the screen (you learn that there are
five questions to your exam, each of
which is a koan. The answers to these

koans are imbedded in the process of
finding and retrieving the five keys
that will fit in the keyslots in the desk.
Upon successfully completing this
task (inserting and turning each key in
its appropriately shaped keyslot in the
desk), you will then receive your
diploma from "The School of
Thought")

press the pad
read the screen (We have an effect on what
is viewed at the subatomic level.
Observation of the macrocosm may
help you understand the physical
manifestation of the true Zen mind:
emptiness. The first koan is: What
effect can one have on something
which doesn't exist?)
press the pad
read the screen (A by-product of accelerat-
ing a particle, an atom, or a molecule
is heat. The second koan is: Why
does one speed to create a nectar
which brings one to rest?)
press the pad
read the screen (All objects are divisible.
Even subatomic particles. In theory,
you could divide the smallest thing in
the universe infinitely. The third koan
is: What is the sound of one duck
quacking?)
press the pad

read the screen (To enter the core of Reality is to know all potential paths for all potential particles simultaneously. This includes all the potential 'yous.' The fourth koan is: How can one be two places at once when you're not anywhere?)

press the pad

read the screen (As a physicist, you know that matter cannot be created or destroyed — only transformed. As a metaphysicist, you must learn that death, too, is only a state before another transformation. The fifth koan is: How can one be on time when dead?)

take the card

n

sit on the mat (in a puff of smoke, Lorenzo 'Buck' Way appears)

examine Lorenzo

stand up

take the mat

s

w (Chaos Cohen presides over this classroom)

examine Cohen

take the handbook

examine the handbook (it has a place to put your hands into it)

e

e

read the board (Doctor Gravity appears in a puff of smoke. He is floating a few inches off the floor. The robe he is

wearing floats over to and settles on a hook near the ceiling)

examine Doc (he is wearing a pair of glasses)

drop the mat

sit on the mat

wear the handbook (you feel a tingle run up your spine)

meditate on the robe (the robe floats down until its by your feet)

remove the handbook

take the robe

examine the robe (a tag on the collar says, 'Come fly with me'. What a great idea for getting to places higher than you can reach)

stand up

take the mat

w

open the door

s

s

s

wear the robe (you are now floating at the top of the lab)

take the wires (they are yanked from your hands and coil up below)

remove the robe

drop the robe

nw

nw (at the fair booth)

w

s

give the card to Boothe

take the ring

toss the ring (you win and can now take a prize from the shelf)

take the mug

examine the mug (it has a thermos-type liner)

n

w

s

give the card to Karni

take the quiz (the quiz consists of six questions about the Milky Way. The questions are always the same but the order is permuted each time. Here are the questions and answers: 1) Does the Milky Way have at least 10,000 galaxies? N 2) Is the Milky Way a Galaxy containing almost 10,000 million stars? N 3) Is a 3 Musketeers a Milky Way without carmel? Y 4) Is the Milky Way 3.7 parsecs from Earth? N (Note: 1 parsec = 3.262 light years) 5) Is "Cow Tao" another way of saying 'milky way'? Y 6) Is our solar system near the center of the Milky Way? N After successfully passing the quiz, Karni puts a bunch of frozen milk cubes on the edge of the booth)

take the cubes (they are melting quickly)

put the cubes in the mug

n

w

look inside the mug (the cubes will have now turned to milk which is still quite cold. If you bring it to the barker, he

will tell you that you have to warm it up. The rides in the fairground should do the trick)

n (at the whip)

enter the ride

examine the milk (it is now tepid)

s

s (at the roller coaster)

enter the ride

examine the milk (it is now perfectly warm enough to drink)

n

e

e

e (the barker observes your perfectly warm milk and gives you the blue key)

examine the blue key (it has a diamond shaped shaft)

se

se

n

n

n

put the blue key in the diamond slot

s

s

s

drop the mug (don't worry - the milk won't spill out of it)

s

s

sw

s

u

e

d
s
take the pillow
open the pillow
take the note
read the note (To Ginger: I never had a
more beautiful co-star. Can't wait 'til
our paths cross and we collide! With
love, X)
drop the note
n
w
n
ne
n
n
w
w
sw
nw
sw
s
take the club
n
n
n (dangling from a tree is a pinata in the
shape of a sphere)
hit the pinata with the club (Pardee,
dressed as a forest ranger, appears and
asks to see something that allows you
to hit the wildlife)
show the card to Parti (he excuses himself
and "poofs" out of view)
hit the pinata with the club (from its
interior spill out thousands of tiny

ducks, each wearing a Groucho Marx
mask. All but one take to flight)
e (the duck follows you. There is also here
now a small book lying nestled in the
cattails and pussywillows)
drop the club and the card
take the book
examine the small book (the cover is a
picture of a sleeping cat)
read the small book (it's written in
catscript — maybe a cat could
understand it)
w
w
wait (the duck will pull out some of its
feathers and feather one of the nests.
The duck then sits in the nest)
look (you see a pile of feathers)
put the feathers in the pillow
close the pillow
e (the duck should still be following you)
se
point to the key (the duck leaps into the
pond and retrieves it for you)
take the key
examine the green key (it has a square
shaft)
se
ne
e
e
n
n
n
put the green key in the square slot
s

s
s
s
s
sw
s
u
e
d
s
take the brush
examine the brush (it resembles a paint-
brush)
n
u
e (an immense cat stalks you)
read the small book to the cat (it falls
asleep at your feet)
e
d
s
examine the clock (sitting in the back of it
is a red key)
examine the key (it has a rectangular shaft)
touch the key (you are fried and then asked
if you would like to be fried again.
Respond: yes. You are now floating
in a transparent bubble which is
attached to your body, an immobile
form, by a silvery cord)
w
examine the painting (note the key looped
over the paintbrush. This is a clue as
to how to get the key from the back of
the clock)

e
e
push the key with the brush (an arc of
energy jumps from the clock to the
ground. You get the red key)
drop the small book and the brush
take the clock
n
w
w
w
w
n
ne
n
n
drop the clock and pillow
n
n
n
put the red key in the rectangular slot
s
s
ne
ne
e
e
examine Doc (he's wearing a pair of
glasses. You will need to get these
from him)
Doc, release a kite
drop the mat
sit on the mat

wear the handbook
meditate on the tachyon (the tachyon is the
speediest thing known to mankind
(see the rules to the kite races on the
flyer that came with the game). In a
flash, the book shows you the follow-
ing pattern:

- - 0 - -
- 2 0 0 -
1 6 3 0 0
- 0 5 4 -
- - 0 - -

Follow the numbers in sequence (starting
with "1" at Race Course 5) to guide
you in the direction of the correct path
through the race course to win the kite
race)

e

ne

se

se

w

nw

w

w (Doc Gravity congratulates you for
winning the kite race and offers you a
pair of glasses as a reward)

examine the glasses (they're made from
prisms and work like a teleidoscope)

remove the handbook

take the glasses and the mat

w

n

wear the glasses

examine the teddy bear (in the back of it is

a yellow key)

take the yellow key and the teddy bear
drop the glasses

s

w

sw

sw

n

n

n

examine the yellow key (its shaft is
triangular)

put the yellow key in the triangular slot

s

s

s

drop the teddy bear

take the wires

se

se

s

e

n

turn the faucet

s

w

n

e

se

examine the dial (repeat until the needle
points to the "0" mark)

open the door

s

turn the faucet (beside the hole in the south
wall)

turn the handle	nw
turn the wheel (water starts to rush into the museum)	nw
n	sw
close the door	sw
examine the dial (repeat until water again builds up in the chamber and the needle points to about the "1/2" mark)	w (if you didn't have the glowing rock, you couldn't see in here)
e	w
n (water should be coming out of the pipe in the ceiling and flowing into the waterwheel. If not, wait a few moves until it does)	w
examine the generator	u
attach the wires to the generator	push the black button (the projector comes to life. The laser outlines a rectangle on the ceiling. It traces the path over and over until somehow a piece of the 'sky' floats down into the room below. The piece of 'sky' resembles a black piece of cloth about the size of a blanket)
n	d
examine the slab	e
attach the wires to the slab	take the blanket
examine the slab (the wires light up like a liquid crystal display and show you the codeword for security clearance. This codeword will change each time you play the game)	e
w	e
examine the terminal (now you know what you need the codeword for)	examine the jar
type XXX (where "XXX" is the codeword you saw in the slab. The case pops open giving you access to the laser)	drop the mat
take the laser	sit on the mat
sw	wear the handbook
s	meditate on the jar (you see an image of it covered by something that obscures your view of it)
take the rock	put the blanket on the jar
n	break the jar (the explosion is absorbed by the cloth)
w	look (you see the violet key)

drop the handbook
take the key
examine the key (its shaft is circular)
drop the rock
stand up
take the blanket
e
ne
ne
n
n
n
put the violet key in the circular slot
turn the blue key
turn the green key
turn the yellow key
turn the red key
turn the violet key (Parti presents you with
your diploma)
s
s
s
drop the jeans
take the mug, clock, pillow, and bear
s
s
show the diploma to Ty (he peels off his
sweater revealing his suit beneath. It's
Parti)
s
sw
e
e (at the main seating)
sit on the seat (Parti sits beside you.
Rockettes appear on stage followed by

Fred, a Star. Fireworks begin and
Fred vanishes. Parti leaves to go
backstage to see the performer.
Someone three rows back jumps up
and shouts "Fire". You run for your
life. You are outside the theatre
entrance (alcove) in a meltdown area.
You're starting to have some trouble,
concentrating. You'd better head back
to the bedroom and get some rest)
n (you will have to repeat each of the
following commands several times to
get them to be successful)
n
e
e
e
e
sleep (you dream about Fred, a Star and
watch him kiss Ginger on the cheek
and wave farewell to his fans. The
walls of the bedroom melt as the lid to
the shell opens, revealing the real
laboratory. Dumont shouts, "We got
it, the bubble path of Particle X!" You
say, "Piece of Cake." As you step out
of the black shell, you feel strangely
light. Dumont looks the same as when
you left, moments ago in the lab. The
walls of the lab appear to glow. You
blink your eyes and suddenly every-
thing is the same as it was before.
Except, you can see the molecules in
everything dancing, dancing, danc-
ing).

Dream Zone

s	w
get plunger	n
get toothbrush	e
brush teeth	ask the clerk about form 69B-12C (he tells
n	you to go to room N3L-D. This will
e	be located on the third floor in the
n	north wing)
give money to brother (he leaves to buy	n
candy)	u
open chest	u
get gun	n
s	n
w	n
open dresser	n
get sandwich	w
get pajamas	ask officer about form 69B-12C (he tells
wear pajamas	you that officer S3R-D deals with that.
enter bed (you go to sleep and enter a	Go to room N4R-E and ask about
dream - the screen will now change	officer S3R-D)
from black and white to color)	e
e	s
e	s
use toothbrush in keyhole (the gate opens)	s
drop the toothbrush	s
e	u
s	n
e	n
talk to fox (He offers to sell you an i.d.	n
Note: If you hadn't brushed your	n
teeth, he wouldn't have spoken to you)	n
buy i.d. (he tells you need to have form	e
69B-12C. The red tape is just	
beginning)	

ask officer about officer S3R-D (he tells you to ask for him in room N2L-D. Getting frustrated yet? There's lots more red tape to come)

w
s
s
s
s
s
d
d
n
n
n
n
w

ask officer about officer S3R-D (he tells you he's in room S3R-D. Surprised?)

e
s
s
s
s
d
s
s
u
u
n
n
n
n
e

ask officer about form 69B-12C (he tells you he wants form 43A-81G from room E4L-C. When you get there he will want form 11X-16B from room E3R-D and form 51M-970 from room E2L-B etc., etc. Continue this rat race until you eventually get to room S4R-E)

ask officer about form 17D-16B (he says he's hungry)

give the sandwich to the officer (you get your form — the beginning of success. Now go to room S2L-A) (in room S2L-A) ask officer about 16D-970 (he won't give it you and suggests you shoot him. You might as well do what he suggests)

shoot officer (as you blow him away he drops the form)

get form 16D-970 (Now take these two forms back to E2L-B and E3R-D and continue winding your way back through the red tape)

(in room E2L-B) give form 16D-970 to officer (he gives you form 51M-970)

(in room E3R-D) give form 17D-16B to officer (he gives you form 11X-16B. Now take these both back to room E4L-C)

(in room E4L-C) give form 51M-970 to officer

give form 11X-16B to officer (he gives you form 43A-81G. Bring this form to room S3R-D)

(in room S3R-D) get rock	show i.d. to Bonzo
give form 43A-81G to officer (he tells you he can't give the 69B-12C now since he is out of receipts. HOW FRUSTRATING. Makes you want to steal it from the son-of-a-gun)	s
steal form 69B-12C (he threatens to report you to the guards unless, of course, you shoot him. Go ahead and do it. He deserves it)	talk to twins (they offer you a piece of gum)
shoot the officer (as he dies he tells you to make sure and get form 22Z-13I from S4L-B and bring it to room S2R-A.... Typical bureaucrat....red tape right until the bitter end)	ask twins for gum
(in room S4L-B) ask the officer for form 22Z-13I	ask bartender about keg (he says he'll trade you one for some bar snacks)
(in room S2R-A) give form 22Z-13I to the officer (at last the red tape is over - he gives you a receipt allowing you to leave the building. Go to the D.O.I. foyer)	get jacket
exit (back at the town square)	w (the keys to the John were stolen by the Rats. If you get form 43E-61Q, the bartender can get two new keys. This is a false clue)
drop the receipt	n
s	u (Nick the Rat is here)
e	ask Nick about the keys (he asks if you want to buy them)
give form 69B-12C to the fox (you get your fake i.d.)	buy the keys
w	d
w (the crowd is thirsty. Be a sport and offer them free beer in the bar)	n
say 'free beer for all' (the crowd stampedes and carries you along with them to the door of the bar)	n
	get the wafer
	s
	s
	give the keys to the bartender (he offers you the use of the John)
	give the wafer (the bar snacks) to the bartender (he gives you the keg)
	examine the keg (it's empty - it will make a good floatation device)
	n
	e (the i.d. salesman has been replaced by a loan shark)
	talk to the shark (he offers you a loan)

buy the loan (you owe him 100,000 tuna. What a deal!)	marry the girl kiss the bride
w	s
s	s
w	s
enter the window (you wind up in a clown's dressing room)	w w w
s	w (you learn that you must first prove your honor by defending the palace before being allowed to meet the Emperor)
s	
s	
drop i.d.	n
buy the tickets	n
s	w
talk to the captain	w
say 'ready' (he doesn't like debtors on board (remember you bought a loan from the shark), Curses. What a good idea!)	dig (you uncover a vase and worm nest) drop the soap get the vase get the worms
hell (or any other curse word. You wind up in the romper room)	w w
get the soap	s (the enemy ninja leaps down off the wall ready to attack)
wash the mouth (you wind up back in the crowd)	shoot the ninja (the water from your brother's water gun melts him. He disappears in a puff of foul smoke)
examine the girl (she's the type you would bring home to mother)	
propose to the girl (she accepts. Time to go to the chapel)	n e
say 'free beer for all'	e
n	e
n	e
n	s
talk to the preacher (he's the spitting image of the fox with the fake i.d.'s)	s e

s (at the dock. Fishing is allowed by	n
couples only. Fortunate for you that	n
you got married)	w
fish (you catch a 100,000 lb. tuna. Fortu-	s
nately, you had your worms for bait.	w
Now you can pay off the loan)	n
drop the worms	n
get the tuna	e
swim	talk to the princess (she wants a token of
n	your appreciation)
talk to Jacque	s
give the keg to Jacque (he gives you a	e
pearl globe)	e
s	e
u	e
n	s
w	w
w	enter the window
bow to the Emperor	s
talk to the Emperor	buy the ticket
give the rock to the Emperor	e
s	give the gum to Grajunk (he joins you)
w	talk to hairy momma about the tonic (it's
n	yours for something sweet)
n	w
w	s
s	talk to the kids about the candy
s	s
talk to the servant	w
give the vase to the servant	talk to the lady
s	play
e	steal the tokens
e	steal the bear
e	e

n
give the tokens to the kids (they give you
the candy)
n
e
give the candy to hairy momma (she give
you the tonic)
w
n
n
e
n
w
w
w
w
s
w
n
n
e
give the bear to the princess (she joins you)
get the rock
e
e (in return for bringing his daughter to
him, the sword smith gives you his
sword)
give the jacket to the smith (he gives you
some rice)
w
s
s
s
w

w
w
w
give the rice to Sushi (he offers you a favor
from any rat)
e
e
e
e
n
n
e
e
e
e
give the tuna to the shark (you pay back
the loan)
w
s
w
talk to John (he points out his sharp teeth)
talk to John about teeth (he offers to
perform a task for you with his teeth)
talk to John about task (in return for the
favor you did for Sushi, he will come
along and help you with one task
requiring sharp teeth)
enter window
s
s
s
s
s (John gnaws through the rope thus
repaying his debt. He leaves)

give the globe to the captain (he offers to
fly to the castle)
say 'ready'
n (at the castle door - you face a bottom-
less pit)
jump west
hit the drunk (he drops his bottle of wine)
get the wine
jump north
jump (you are face to face with Rambone
the Rat)
talk to Rambone (he has no hair and is
about to kill you)
give Rambone the tonic (Grajunk in his
excitement jumps so high that he
knocks a hole in the ceiling)
u (at last the key that will get you back
"home" and out of your dream)
exchange the rock with the key
d
d
s
say 'ready'
n
n
n
n
n
n
e
n
n
w
w (you face a demon)

use the sword (you wound the demon)
throw the wine at the demon (the acid wine
dissolves him into a puddle of goo)
use the key (as you fumble with it, Grajunk
swallows it. Thank heavens you have
that trusty plunger that you took with
you at the beginning of the game from
your bathroom)
use the plunger (you recover the key)
use the key (you wake up and are back in
your bedroom)
e
n
give brother the gun (much to your disgust,
he runs over and hugs you. You have
won the game)

GrailQuest

This game is primarily of the adventure type but has some aspects of a fantasy game in that several locations feature characters that must be fought and defeated using your accumulated weaponry. Since an exact command sequence cannot be written for succeeding in these encounters nor do the battles themselves always occur at the *exact* same location, this aspect of the game shall only be alluded to in the complete solve listed below. The player must use his or her own ingenuity and luck in defeating opponents. After answering "yes" to the King

n	mount horse (you need to ride a horse if
examine siege (it is not yet the time to sit	you are to venture onto the King's
on it)	highway west of the West Gate)
w	w
pray	w
s	w
open the door	n
s	w
take the armor, helmet, and mace	n
open the doors	dismount
s	e (a young woman who is kneeling at the
take the horse barding	altar jumps up and approaches you
n	asking for your help. Answer "yes" and
n	she will offer you a
w	cross which if you kiss will heal your
s	wounds)
take the bowl, cleaver, and knife	take the cross
examine bowl (you find a lump of sugar)	w
take the sugar	mount
search (you find some bread)	s
take the bread	w
n (the horse should still be here)	w
give sugar to the horse	w
put horse barding on horse	w

w (you will usually encounter a highway-	s
man here. Fight and defeat him and	e
you will get his saber and silver	e
sovereign. Take them)	e
n	e
n	e
search (you will usually encounter a hag	e
here. If she doesn't immediately	e
appear, just try to move away from this	e
location and she	n
probably will. She asks if you will	n
grant her one wish. Answer "yes" and	w
she will give you the answer to a riddle	w
which you will need to know later	w
on. The riddle pertains to what women	w
most desire. Answer: their will!	n (at Tal-y-Ilya. You meet a hermit here.
She tells you that you will meet up with	He asks if you have some food.
her again in the Chapel of the	Answer "yes")
Arimathean saint)	give bread to man (he tells you an impor-
e	tant piece of information about the
dismount	Solomon sword, namely, that it is not
e	used to <i>take</i> life but rather to
pray	<i>give</i> life)
search (a Solomon's sword and a shield	s
appear)	e
take the sword (you can't take the shield	e
until you are worthy meaning that	n
you must first perform some more	w
noble deeds)	search (you discover a chest)
w	open chest
mount	examine chest
w	take the gold sovereign
s	e

s
e
e
n
n
n
w
s
dismount
w (at Death's Door . You see a body
here)
examine body (it's Sir Lancelot. He is
wearing a medallion)
swing Solomon's sword (you revive Sir
Lancelot and in return he gives you a
brooch which when kissed will heal
you when you are bleeding and the
medallion to take to Queen Guenever)
drop the bowl
take the medallion and the brooch
e
mount
n
e
s
s
s
s
s
e
e
n
w

n (at the smithy. You should leave your
horse here since, in this part of town,
if you dismount and leave it outside
while you enter a building, it
might be gone (stolen) when you come
out. Garth asks if it is a deal.
Answer "yes")
give silver sovereign to Garth (he will hold
your horse for you until you return)
s
e
n
pray
search (you discover several brass plates
set into the floor marking the
graves of distinguished knights and
nobles)
examine plates (Sir Lamorak is buried
here)
s
s
e (you will meet a pilgrim here. If not, he
will appear as soon as you
try to leave this location. Do a good
deed and give him a donation)
give copper sovereign to pilgrim
s
e (Queen Guenever should appear. If not,
"search" and she will most likely
appear. She will ask if Sir Lancelot
gave you something for her.
Answer "yes")
give the medallion to the Queen (in return

she gives you a dagger forged by herself)

take the dagger

n

take the sword

s

examine the paintings (they depict each of
Arthur's major victories
over the Saxons)

w

n

n

e (in the Tabard Inn. The innkeeper will
ask you for money for a refill in
exchange for information)

give gold sovereign to Geoffrey (he talks
about drinking water at a lake which
is an illusion and an image of a glass
tower at a clearing)

w

n

n

examine books (one stands out)

open book

read book (three times. You will learn the
name (Uther Pendragon) of the person
who is buried under the altar at Grant's
Dance)

s

s

s

w

n

w

n

mount

s

e

s

w

w

n

n

w

w

w

w

n

drink water (the lake vanishes and a castle
appears)

n (try to go north again and a beautiful
woman, Viviane, will appear and
give you a talisman to assist you in
entering the Merlin's tower of
glass. Remember what Geoffrey talked
about)

take the talisman

s

s

w

n

w

w (in a clearing)

rest (a tower appears)

n (possession of the talisman allows you to
enter. Merlin appears and gives you
the Philosopher's Stone to place on an
altar that is different from all the rest.
Then speak the name of him who lies
beneath it. Remember what you read in
the book in Guild Hall)

s
e
e
s
e
e
e
e
e
s
s
w
w
w
w
dismount
n
put stone on altar
say Uther Pendragon (you wind up in a
cavern with no apparent way out)
examine grate
open grate
take the spear (it's broken in two. You are
now back out at Grant's Dance)
s
mount
s
s
e
e
e
e
e
e

dismount
n (a nun asks your help in returning the
relic of St. Thomas to the chapel.
Answer "yes")
pray (It's time to go and fight the Evil
Knight in Tintagel that the lady at the
altar in the Salisbury Cathedral talked
about. First, however, go back
to the White Chapel and get the shield)

s
mount
w
w
w
w
w
n
n
w
w
w
w
w
w
w
n
n
e
dismount
e
take shield (you should be worthy by now)
w
mount
w
s
s
e
e

e
e
s
s
w
w (hopefully the tide is low so that you can
cross the bridge to the west. If not
you will have to kill some time until it
does)
w
dismount
w (the Evil Knight appears and asks you a
riddle. The answer was given to you by
the hag in the forest)
their will (now fight and defeat the Evil
Knight. Make sure you "kiss cross"
several times during the battle to heal
your wounds. The sword you found in
the Tower Armory is a good weapon to
use here. Also make sure you are
wearing the armor, helmet, and shield.
After you finally defeat the knight, a
key will appear)
take the key
d
open east door
e
search (you find a cudgel)
drop the knife
take the cudgel
w
unlock the west door
open the west door

w (you set Cador free. He offers you an
amulet which if worn around
the neck will protect you from dark
magic)
drop the mace
take the amulet (Now return to Cador's
sister at the high altar in Salisbury
Cathedral to collect your just reward)
e
u
e
mount
e
e
e
e
n
n
w
n
dismount
e (the girl thanks you and asks you to
marry her. Answer "No" (remember
you made a promise to the hag. Guess
what it will turn out to be). She will
nevertheless provide you with an
important piece of information that you
will need in the Chapel Perilous)
pray
w
mount
s

e
e
e
n
n
n
n
n
w
w
w
w
n
w
w
n

w (at the Abbey)

s (a peasant will appear and ask you for help. Answer "yes")

dismount

w (you encounter the snake. To defeat the snake you must use a magical weapon. Try the cudgel repeatedly until you succeed)

u (you encounter the Dark Sorcerer. To defeat him you must use a weapon that is not made by the hand of man. Remember the dagger Queen Guenever (certainly not a man) gave you and said that she had forged herself)

break the mirror

drop the cudgel

take the reliquary (it is inscribed "St. Thomas". Remember the lady in the Canterbury cathedral)

examine the desk (it has three drawers.

You must open the right one else you will be destroyed)

open the second drawer

examine parchment (it explains how to move once you enter the Wasteland, i.e., like a knight in the game of chess - two moves forward (north) and one move right or left (east or west). Now head for Canterbury to return the reliquary to its rightful owner)

d
e
mount

n
e
s
e
e
s
s
s
s
s
s
s
s
e

e (outside the Canterbury cathedral)

dismount

n

pray (the woman appears and thanks you for returning the relic. Now head back to the chapel in Camelot where the hag told you to meet her)

s

mount

w

w

w

w

n

e

e

e

dismount

e

n (you once again meet up with the hag

who asks you to marry her. Answer

“yes”. A monk appears to perform the marriage service)

kiss the bride (the hag turns into a beautiful

(nude) woman. You are now

in a room called Wedding Night. Your

newly acquired wife asks whether

you want her to be beautiful by day,

night, or at her choice (remember

woman’s strongest desire is her own

will))

your choice (she will then tell you which

piece to move when you encounter

the Deadly Chessboard. This piece,

e.g., queen, knight, pawn, etc. will

change each time you play the game)

s

e

n

e

examine siege (it should now say that it’s

Percival’s seat. If not you haven’t

performed enough good deeds yet. Go

back and see if you have prayed

everywhere you were supposed to)

sit on the siege (you learn what you must

do after you enter the Chapel

Perilous)

w

s

w

mount

w

w

w

n

e

e

n

n

n

n

n

n

n

n (in the Waste Land. Now go two moves

north and one move west)

n

n

w (at the Deep Defile)

n

dismount

w

pray

rest (continue to do this even after the
Demon appears and starts attacking
you. Eventually the wind will blow
him away)

e

e (there should be a boat here now. If you
had come here before entering the
Chapel Perilous, you wouldn't have
found the boat)

examine the boat (the inscription on it asks
for your trust of the Maker for His
protection)

drop the armor, helmet, and shield

enter the boat (you wind up at the Sword
Bridge)

n (your feet get cut up and they start to
bleed. You are 40 ft from the castle
entrance)

n (you are still 20 ft. away from the castle
entrance. Remember your instructions
about not shedding any blood. Also
remember the gift you got from Sir
Lancelot)

kiss the brooch

n (you meet up with the Fisher King)

mend spear (you now have in your
possession the Holy Spear)

touch the Fisher King with the Holy Spear

u (you are now at the Deadly Chessboard
and it's your turn to move)

XXX (where "XXX" is the chess piece
your wife told you to move)

e

take the holy grail

Guild of Thieves

jump to the jetty (score = 5)	u
w (an old man is here dragging an extremely heavy trunk)	s
say "can I help you?" (the man is grateful for your help. The gatekeeper of the castle lowers the drawbridge allowing the old man to enter) (score = 10)	s
n (in the entrance hall of the castle)	look at the cabinet (there is a mirror on it)
w	take the mirror
examine the bucket	n
break the coal (a fossil is revealed) (score = 15)	n
take the fossil	e
s	n
examine the paintings (one is an oil that is a classic painted by Ripov during his dead period. The second is a water-colour that depicts a wandering minstrel, playing a lute and floating above the ground, singing the words 'urfanore pendra'. The third is a gaudy painting that is an object lesson in how to fail as an artist)	look at the cue rack
take the oil painting	take the cue
s	look at the table
examine the settee	open the red ball (score = 20)
open the cushion	look inside the red ball (it contains a diamond ring)
look inside the cushion	take the ring
take the note	e
examine the note (it's a five ferg note)	look at the stool
n	open the stool
n	look inside the stool
e	take the plastic bag
	look inside the plastic bag (it contains a sheet of music)
	read the music (it's a mixture of musical and mathematical symbols)
	s
	s
	examine the bed (on it is a sewing box)
	open the box
	look inside the box
	take the needle and cotton (the cotton is actually fixed to the needle)
	open the wardrobe

look inside the wardrobe
take the dress
n
w
w
d (keep wandering around the castle or
wait right here until the gatekeeper
shouts "the rat race will start soon")
s
examine the rats (the betting odds for the
grey rat are 10 to 1. You must bet on
this one in order to win enough money
to later buy a lute)
bet on the grey rat with the note (the rats
are off. The grey one wins by the
length of a whisker. You get your
winnings in the form of a cheque
made out for fifty-five fergs. The
gatekeeper also leaves you a memento
of the race - a small bird cage) (score
= 28)
take the cage
n
e
s
open the swag bag
look inside the swag bag
turn on the lamp
e
s
move the junk (you clear a path allowing
you to go south) (score = 33)
take the cube
s

open the safe
put the ring, painting, and fossil in the safe
close the safe (score = 66)
open the safe
put the plastic bag in the safe
close the safe (score = 76)
open the safe
put the dress in the safe
close the safe (score = 81)
drop cue, cotton, and needle
put the mirror and cage in the swag bag
n
n
w
n
w
s
s
s
se
look at the windmill (in the open door, you
see the miller)
shout "stop the windmill"
s (inside the mill - the miller gives you
some gum) (score = 86)
buy the lute with the cheque
examine the lute (it has a silver plectrum
on it)
get all from the bag
put the lute in the bag
n (score = 101)
nw
n
n

n
e
s
s
open the cabinet
look inside the cabinet
take the key
s
look under the bed (you find a tub)
open the tub
look inside the tub (it contains a maggot)
take the maggot
n
n
e
s
s
tie the cotton to the cue
put the maggot on the needle
hold the cue
put the needle in the moat (you catch a
fish) (score = 109)
untie the cue from the cotton
drop the needle and the cotton
n
n
w
open the cupboard
look inside the cupboard (it contains rat
poison and a jar (of jam))
take the poison and the jar
n (at one end of the table stands a cage
with a grizzly bear)
look inside the cubic cage (in it are a bear
and a chalice)

put the poison on the fish
feed the fish to the bear (that takes care of
the bear)
open the cubic cage with the key
take the chalice
w
n
examine the door (it has a horseshoe on it)
rub the horseshoe
e
open the jar (some of the flies swarm into
the jar and are stuck there)
w
s
u
s
s
look at the bed
examine the abstract painting (it really
isn't a canvas at all. It's a thin sheet
of metal)
move the abstract painting (behind it is a
dark hole that leads into nothing)
open the cabinet
drop the cue
n
n
d
e
s
e
open the door
n
examine the drainage system
take the pipe

open the stopcock
wait (the cellar is half flooded)
close the stopcock (virtually all of the rats
have drowned)
n (score = 124)
look at the bottles (the champagne bottle
has a label on it that tells you that if
you first shake it and then say "hoo-
ray" it will explode - a handy piece of
information to be used later on in the
game)
take the champagne bottle
open the red bottle
look inside the red bottle
take the ruby
s
s
s
s
open the safe
put the ruby, plectrum, and chalice in the
safe
close the safe (score = 169)
n
n
w
n
w
s
s
s
sw
s
s (in the antechamber)

read the notice board (in the "laity"
section, the name Kol Kauth catches
your eye. In the "clergy" section, the
name Doriman Grunchkev catches your
eye)
s
examine the altar (there is an incense
burner on it)
take the burner
s
examine the hive (there are gloves on it)
take the gloves
n
se
u
take the rhino
d
nw
sw
u
e
examine the organ (there is an ebony key
and an ivory key on it)
take the keys
w
d
ne
n
open the safe
put the rhino and burner in the safe
close the safe (score = 179)
n
n
n
w
w

se

open the gate

se (in the cemetery)

examine the tree

take the berries

nw

s

examine the door (it consists mainly of a

large glass window in a wooden
frame)

break the window

s (score = 186)

examine the counter (there is a flap on it)

lift the flap

s

examine the till (it has a button in it)

push the button

look inside the till

take the coin

examine the coin (it's worth two fergs)

n

n

n

nw

ne (entrance to zoo)

examine the gate (there is a slot in it for

inserting a two ferg coin)

put the coin in the slot

e

s

w

take the snake skin

e

n

n

w (score = 196)

examine the tree (it has a coconut on it
which is out of reach)

shake the tree (the coconut falls)

take the coconut

drop the jar (sensing food, the spider

crawls into the jar and gets stuck to
the jam)

take the succulents (score = 206)

e

e (a squawking macaw is here - he says

he's hungry and you need some
information)

w

s

s

open the door with the ivory key

e

examine the desk

open the drawer

look inside the drawer (it contains a
magazine and a grotty key)

take the grotty key

read the magazine (it has a feature article

on macaws liking fresh coconut better
than anything)

w

n

n

e

hit the large cage with the coconut

give the coconut to the macaw (the bird

talks about a potion the Baron made

for him consisting of snake skin, heart,

eye, and berries) (score = 211)

w
s
s
e (forget about the spade and the food)
open the door
ne
open the door with the grotty key
open the cage
nw
put the mynah bird in the cage
close the cage
say "hello" (the mynah bird responds
similarly) (score = 216)
se
sw
w
n
w
sw
nw
nw
examine the coals
rub succulents on feet
w (score = 226)
u
se
take the yellow die
se
sw
take the green die
ne
ne
take the blue die
sw

se
take the red die
nw
examine the case (it is opaque and has four
coloured slots in it)
examine the slots (the first is red, the
second is green, the third is blue, and
the fourth is yellow)
roll the dice (Lady Luck appears and asks
what number you require)
five (she tosses the red die on the floor -
when you retrieve it, you notice that it
now has five spots on it. Again she
asks you what number you require)
five (she tosses the green die on the floor -
when you retrieve it, you notice that it
now has five spots on it. Again she
asks you what number you require)
five (she tosses the blue die on the floor -
when you retrieve it, you notice that it
now has five spots on it. Again she
asks you what number you require)
five (she tosses the yellow die on the floor
- when you retrieve it, you notice that
it now has five spots on it)
put the red die in the first slot
put the green die in the second slot
put the blue die in the third slot
put the yellow die in the fourth slot (the
clasp on the case dissolves magically)
(score = 256)
examine the case (it contains a plastic die)
take the plastic die
nw

nw
d
rub succulents on feet
e
se
sw
examine the wax (a gem is stuck in it)
shine the beam at the wax with the mirror
 (the wax melts and the gem falls
 down) (score = 261)
take the gem (score = 266)
ne
se (unbreakable-looking iron bars prevent
 passage to the southwest)
break the bars (surprise - you are able to do
 it) (score = 276)
sw
examine the skeleton (one of its finger
 bones is resting on a chest)
take the bone
open the chest
look inside the chest (it contains a heart)
take the heart
s
w
examine the ladder (it's tied into a tight
 ball)
untie the ladder (score = 286)
e
n
ne
e
e
s

s
s
open the safe
put the gem in the safe
close the safe (score = 296)
s
nw
d (engraved in large letters above the
 southeast exit is the word
 "WOBNIR" which is RAINBOW
 spelled backwards)
se (black square - to get to the white
 square, move through the colored
 squares in the order of the colors in
 the rainbow)
se
n
e
e
se
s
sw
e (score = 311)
se
examine the sarcophagus (it's locked)
open the sarcophagus with the bone
look inside the sarcophagus (in it is a skull)
examine the skull (it contains an eye)
take the eye
e
examine the statuette
take the statuette
open the black door with the ebony key
e (score = 316)

read the pamphlet (it explains a new
method of 'fire walking' - rubbing
succulents on the soles of the feet
before walking across hot coals)

w

w

nw

nw

n

nw

e

sw

sw

nw

n

nw

u

se

n (back at the antechamber)

open the safe

put the statuette in the safe

close the safe (score = 326)

s

move the statue (you fall down into a well)

drop the statue

d

n

n (score = 343)

n

take the brooch

dig in the sand (you find some boots)

wear the boots

d

d

wear the gloves

s

e

drop the mirror, keys, and bone

take the pick

w

w

hit the minerals with the pick (you break
off some chips from it before the pick
shatters)

drop the pick

take the chips

e

s

u

e

n

ne

se

s

w (at the Bank of Kerovnia)

open the safe

put the brooch and chips in the safe

close the safe (score = 363)

e

n

nw

e

e

e

n

n

n

u

s	n
s (back in the main bedroom)	w
examine the cabinet	w
read the plaque (the bed is a folding bed.	d
Now you want to make it fold up with	e
you in it)	s
examine the buttons	e
take the cue	s
sit on the bed	s
push the top button with the cue (the bed	open the safe
folds up flinging you through the hole	put the china pot in the safe
that revealed itself when you moved	close the safe (score = 395)
the abstract painting. You wind up in	n
a secret laboratory. It's time to	n
prepare the Baron's potion that the	w
macaw spoke about) (score = 370)	n
examine the cauldron (it contains a sachet)	w
put the cube (with the Baron's picture on	s
it), heart, eye, berries, and snake skin	s
in the cauldron	s
open the sachet (the cube is transformed	w
into something strange) (score = 390)	w
look inside the cauldron (it contains an	w
anticube)	se
take the anticube	s
w	w (back at the Bank of Kerovnia)
n	open the door
n	examine the jeans
e	look inside the pocket (it contains a plastic
e	card)
s	take the plastic card
look under the bed (there is a china pot	e
there)	n
take the china pot	nw

nw	play lute and sing urfanore pendra (you
nw	float up into the air)
get the lute	s (into the office - you fall back down to
put the plastic die and anticube in the	the ground)
pocket	e (in a cubical room)
rub succulents on feet	roll die
w	six
u	d
drop the cue, bag, lamp, and succulents	roll die
d	five
e	w
se	roll die
se (don't worry about it being dark. Just	two
make your way back to the bank)	ne
se	roll die
s	one
w	nw
s (score = 425)	roll die
say to mynah, hooray (repeat until the bird	four
echoes you, i.e., it also says "hooray")	d (you are in a cubical room containing all
join longer line (score = 430)	of the deposits you previously made
show card to teller (you are escorted into	in the night safes)
Mr. Peckham's office) (score = 445)	take all
chew gum	examine the pillar (on top of it is a
drop bottle and cage	weighing machine)
shake bottle	examine the weighing machine (there is a
wait (the manager leads you out of his	cube on it)
office and locks the door behind him)	examine the cube (it's the same size as the
put gum in keyhole (first you hear a	die - now the trick is to replace the
squawk and then an explosion occurs	cube with the die without setting off
— obviously, the mynah bird said	the alarm. Here's where the anticube
"hooray" thus causing the champagne	comes in handy)
bottle to explode as per the informa-	put the die and anticube on the weighing
tion on its label. Everyone rushes out	machine (the anticube cancels the
of the bank)	

weight of the cube and the die takes its place)

take the cube and the anticube (score = 485)

read the signposts (notice that northwest corresponds to a spade. Remember the spade in the zookeeper's office. You are in the equivalent of the red room so head back to the boathouse)

nw

nw

nw (back at the boathouse) (score = 500)

take all

d

rub succulents on feet

e

se

se

e

e

e

e

e

pull on the rope

jump to the boat (you are congratulated and officially welcomed to the ranks of the Guild of Thieves. You have achieved the impossible score of 501)

Jinxter

- inventory (you are carrying a keyring and bus ticket. You are wearing a pair of trousers and a shirt)
- examine the keyring (it contains a yellow plastic key, a rusty key, and an iron key)
- examine the bus ticket (it specifies the destination as Neverending Lane)
- wait (the inspector comes by and asks to see your ticket)
- show the ticket to the inspector (he informs you that Neverending Lane is just two stops from here)
- read the sign (it warns passengers not to talk to the driver while the bus is in motion)
- examine the button (it tells the driver to let you off at the next stop. The bus sails past a bus stop. You want to get off at the next stop)
- push the button
- wait (repeat until the bus comes to a halt besides a bus stop and the doors open)
- exit (the inspector tosses your keyring out the bus after you) (score = 5)
- take the keyring
- wait (twice. You are propelled to the kerbside by a firm grip on your collar belonging to a large, pot-bellied figure hovering a couple of feet above the ground and eating a cheese sandwich. He tells you that he is one of the Guardians, currently attached to the Department of Turani, Sacred Charm Subdivision. He mutters some gibberish about wosnames, witches, etc. He hands you a document)
- read the document (it's the one in the sealed envelope that came in your game package. Read it now. The man describes your job: "Reassemble the bracelet of Turani, turn its amazing occult wosname, force, on Jannedor, and save civilization as we know it". He then fades away from view)
- drop the ticket and the document
- open the gate
- n
- examine the chair
- unlock the door with the iron key
- open the door
- n
- nw
- open the cello case
- look inside the cello case (it contains a harmonica. There's plenty of room for more items)
- take the case
- open the wardrobe
- look inside the wardrobe (it contains some tap-dancing shoes)
- wear the shoes
- look under the bed (you find a woolly sock)

take the sock and put it in the case
ne
examine the book (it's entitled: "Sheep
Throughout History")
read the book (it puts you "asleep")
examine the basin (it contains a dragon)
examine the dragon (it's a plastic toy)
take the dragon and put it in the case
sw
n
examine the table (there a tin opener in it)
take the opener and put it in the case
open the fridge
look inside the fridge (it contains a bottle
of milk)
take the bottle and put it in the case
close the fridge
e
s (in the library. The telephone is ringing)
answer the telephone (it's your old friend
Xam. He sounds in a panic. There's
something strange going on over
there. You'd better get over there
immediately)
examine the bookshelves (all of your
books have disappeared)
n
examine the table (it has a tablecloth on it)
examine the tablecloth (it's dull red and
very frayed)
take the tablecloth and put it in the case
unlock the back door with the iron key
open the door
n
examine the secateurs

take the secateurs and put them them in the
case
examine the gloves (they will protect
against the tin opener)
take the gloves and put them in the case
n
examine the mailbox (it's made of yellow
plastic)
unlock the mailbox with the plastic key
open the mailbox
look inside the mailbox (it's empty)
close the mailbox
e (you see a bull. Remember the red
tablecloth you brought along)
wave the tablecloth (the bull charges at
you)
drop the tablecloth (the bull redirects his
charge from you to the tablecloth. It
gores the tablecloth and get its horns
entangles in it thus blocking its vision)
(score = 10)
se
e (there's an old bottle caught up in the
weeds)
examine the plastic bottle (it's an old oil
bottle containing some iridescent
fluid)
examine the fluid (it's mostly spring water
with a film of oil from the previous
contents of the bottle)
take the plastic bottle and put it in the case
w
nw
w
s

s
w
open the fridge
put the plastic bottle in the fridge
close the fridge
e
n
n
e
se
se
s
take the mouse trap
take the can of worms
look inside the boat (it contains a bung)
take the bung
n
nw
s (in Xam's front garden)
examine the door
unlock the door with the rusty key
open the door
sw
w
examine the table (on it is a wax candle
and a match box)
take the candle and match box
s (score = 20)
examine the table (on it is a telephone)
sw
s (you spy a magpie, whistling cheerfully)
listen to the magpie (he tries to buy you off
by giving you a pair of old spectacles.
They will soon come in very handy)
(score = 25)

n
ne
n
e
open the trapdoor (a mouse may pop into
the kitchen and, seeing you, pop out
again. You will want to catch him but
you can't yet)
d (it's too dark to see)
wear spectacles (you can now see that you
are in a cheese cellar)
take the cheese
u
put the cheese on the mouse trap
set the mouse trap
drop the mouse trap
ne
look inside the mailbox (it now contains a
postal note)
take the note then read it (it's a notification
from the Aquitania Postal Service
about an undelivered parcel addressed
to you. Dial 300 to arrange pre-
delivery. Reference: #045-776-
86662-921-7/ZZXA55b. Remember
the phone in the study)
sw
w
s
dial 300 (you are told that the delivery
man, Lebling, will call back with your
parcel)
n
e

wait (Lebling appears. He recognizes that you're not Xam and won't give you the parcel. Instead, he puts it in Xam's mailbox and locks it)

ne

unlock the box with the plastic key (it doesn't QUITE fit)

sw

open the matchbox

take the match then light it

light the candle with the match

heat the plastic key with the candle (twice.

You warp the key into a different shape)

ne

unlock the mailbox with the plastic key (it springs open) (score = 35)

look inside the mailbox (it contains the parcel that Lebling put in there.

Surprise!!)

take the parcel then open it (it contains a walrus charm and a letter)

examine the charm (etched into it's surface is the word "Oojimy")

read the letter (it reads as follows: To

Whom It May Concern: If this falls into your hands, they've got me.

Doing this for the sake of my father's

honour. Got to reassemble bracelet.

Been keeping this moving round the postal system. Safest place. Shop-

keepers up to no good. Can't write more. I think they're watching.

Signed: Xam)

sw

examine the mouse trap (there should be a mouse in it by now)

take the mouse

ne

n

nw

w

s

s

w

drink the milk

open the can of worms with the tin opener

put the worms in the milk bottle

open the fridge

look inside the fridge (you see a plastic bottle (of ice) and some oil)

take the oil (in the can that contained the worms)

close the fridge

e

n

n

e

se

se

s

examine the door (it's neglected and rusty)

put oil on the door

open the door

s (score = 45)

examine the sack (it says "SWAG" on it.

It contains an amethyst charm)

take the amethyst charm

examine the amethyst charm (it bears the word "Doodah")

examine the canoe (it contains a paddle. It also has a hole in it below the water level)

put the bung in the sock

put the sock in the hole

put the canoe in the water (score = 55)

enter the canoe

take the paddle

s

s

get out

d

dig in the dirt (you can't; it's too dense)

empty the milk bottle on the dirt (the worms enter and loosen up the dirt mound)

dig in the dirt (it reveals a passage to the east) (score = 65)

e

e (there is some diving equipment here)

drop the shoes, shirt, and trousers

drop all

wear the aqualung, mask, flippers, and suit

w

w

u

n

d

nw

n

open the hatch

d

close the hatch

examine the panel (it has two buttons on it)

examine the buttons (the left one bears the word "FLUSH". The right one bears the word "FLOOD")

push the left button

examine the door (it has a wheel on it)

turn the wheel

open the door

e

d (in the sacristy)

examine the desk (there is a notecase on it)

examine the notecase (it contains a one ferg coin)

take the coin

open the red door

e

examine the chandelier (it has a lapidary glint as through concealing something. Unfortunately, you can't reach the chandelier to see what is being concealed. You must do something about that. Remember the "FLOOD" button)

w

u

w

push the right button (the airlock starts to fill with water)

e

d

e

wait (twice. The water is up to your nose)

look (everything is now underwater and you can swim around like a fish)

u (you are high about the lodge. The chandelier is well within your reach)

examine the chandelier (it conceals a tiny charm hidden by the crazed gardener in a fit of virtue)

take the charm

examine the charm (it's ivory and fashioned in the shape of a unicorn. The word "Watchercallit" is engraved on its surface)

d

w

u

w

open the hatch

u

s

se

u

s

d

e

e

drop the aqualung, mask, flippers, and suit

wear the shoes, shirt, trousers, and gloves

take the case, paddle, match box, candle, mouse, amethyst charm, and walrus charm (from the parcel)

w

w

u

enter the canoe

n

sw

drop the paddle

get out

s (on the village green)

nw

read the notice (its says: "Wanted! - Smart lad to take over as Baker's apprentice. Ask here")

ask baker for job (he tells you to go downstairs and bake some bread)

d

e

examine the flour sack (it's closed)

open the sack

take the sieve

sieve the flour with the sieve (you discover a charm)

examine the sieve (it contains a pelican charm. If the baker catches you with this he will accuse you of trying to steal it and throw you out. You must do something with it in order to get it past the baker and out of the bakery)

take the pelican charm

w

examine the table (there is a baking tin on it)

examine the tin (it contains some dough. You are about to bake a loaf of bread with a pelican charm in the middle of it)

put the pelican charm in the tin

open the oven

put the tin in the oven

close the oven (hopefully the baker has not arrived yet. He will soon hereafter)

examine the oven (it has a panel on its side)

examine the panel (it has a single green button)
push the green button (the dough begins to cook)
push the green button (the loaf of bread begins to cook)
open the oven
take the tin
examine the tin (it contains some burnt bread. You've obviously failed at your baking task)
show the bread to the baker (he suggests going upstairs where there is more light)

u

show the bread to the baker (he takes a bite of it. In disgust, he hurls the bread at you. It flies through the door (just what you wanted to happen). He then accuses you of being a moron and throws you out of the bakery and on to the village green)
take the bread
eat the bread (you remove the charm from your mouth)
examine the pelican charm (enscribed on it is the word "Doofer")
se
examine bar (a sign on a handpump indicates that beer sells for 1 ferg per pint. You will need that one ferg coin later on. So you must figure out a way to buy the beer yet get the coin back. This is where you get to use some of

the magic associated with the words inscribed on the various charms that make up the bracelet of Turani. To learn the meaning of these words, consult the bottom of page 1 of The Independent Guardian, the newspaper that came in your game package)
watchercallit the coin (this makes it glow)
buy beer with coin (the one ferg coin reappears in your hand because of the "watchercallit" magic you cast on it)
watchercallit glass (this will prevent the bartender from taking away the glass from you when you leave the bar)
examine the hearth (a roaring fire is blazing in it)
oojimy fire (it goes out leaving some ash)
take the ash
n
examine the well (it's large enough for you to climb into)
d
take the two-ferg coin
u
s
nw
sw
doofer the unicorn (it springs to life shaking free its saddle. He rises slowly up into the sky above)
take the saddle
ne
open the door
ne (the postmistress is behind the counter)

mail the saddle to the station (You will need it later on in the game. The postmistress puts the saddle on the scales and asks for two fergs)

give the two-ferg coin to the postmistress (she bends down and fumbles around behind the counter for a while looking for something.....)

wait (as she surfaces from under the counter, bloody Lebling sticks his head round the door. She gives him the saddle with directions where to take it) (score = 75)

show the mouse to the postmistress (she rushes out of the room) (score = 80)

examine the safe (it has four handles; one at each corner)

examine the handles (they're all up)

turn the bottom right handle (it's down)

turn the top right handle (it's down)

turn the bottom right handle (it's up; but the bottom left handle is down)

turn the bottom right handle (it's down)

turn the top left handle (you hear a barely audible click from deep in the safe) (score = 90)

open the safe

look inside the safe (you see a dragon charm)

take the dragon charm

examine the dragon charm (it's carved of jade and bears the word "Thingy")

open the door

sw

sw

examine the door

read the notice (it says: "SORRY - NO REPAIRS ACCEPTED")

examine the shop (it has a window)

look inside the window (the window is open. Inside the shop sits a clockmaker fiddling with a watch under the light of an oil lamp)

knock on the door (the clockmaker leaves the place and shuffles out toward the main work area. You've got to do something quickly, since if you wait just one move, the clockmaker will return, chastise you for not reading his notice and slam the door shut in your face)

throw the tin at the oil lamp (the lamp comes crashing to the floor. Oil spills from the burning lamp and sets the room on fire. The clockmaker returns, sees the fire, and hobbles off toward the village green)

sw (you're in the clockmaker's shop)

e

drop all but the walrus charm

w

ne

examine the fire engine (it sports a splendid ladder)

put ladder on shop

take the ladder

examine the ladder (it's missing 8 rungs on either the top or bottom)

sw

oojimy the stool (remember it was hot
 from the fire. It's cold now)
 take the stool
 e
 drop the stool
 put the ladder on the girder
 take all but ladder and stool
 climb on the stool
 climb the ladder (you get to the top of the
 ladder and transfer over to the girder.
 The ladder falls) (score = 100)
 jump north (there are life-size wax figures
 here, a sun weatherman and a rain
 weatherman, poised at either end of a
 wooden beam. One of the figures will
 be on your end of the beam. You
 want the rain weatherman at your end
 of the beam)
 thingy (if the sun weatherman is at your
 end of the beam. Otherwise skip this
 command. The rain stops, the beam
 pivots, and the sun weatherman comes
 outside)
 examine the rain weatherman (his head is
 crowned with a battered old top hat)
 take the hat
 climb on the beam
 take all from case (you wan't be able to
 take the case with you any further)
 drop the case
 doodah (rains begins to fall. Again the
 beam pivots taking you and the rain
 weatherman out to the end of the
 beam. You see a cloud)
 get on the cloud (score = 110)

doofer the cloud (the cloud comes to life.
 It takes off and eventually deposits
 you on the ground where you are
 sitting in a small, sad puddle outside a
 railway station)
 examine the sign (its says: "No Busking
 Whatsoever At All Anywhere on the
 Premises, Look You")
 e
 e
 n
 n
 open the door
 w
 take the saddle (this is the one you mailed
 in the post office)
 e
 s
 s
 w
 put the coin in the hat
 drop the hat
 doofer the shoes (your feet are dancing)
 play the harmonica (your entertainment
 gathers a crowd of tourists. One of the
 tourists drops a silver coin into your
 hat)
 take the hat
 look inside the hat (in addition to the one
 ferg coin, a foreign coin is there)
 buy the ticket with one ferg coin (giving
 you some ridiculous reasoning the
 stationmaster raises the price of the
 ticket to two fergs. You walk away)
 e

wait (repeat until the stationmaster calls you back and agrees to sell you the ticket half-price, i.e., the original price of one ferg)

w

buy the ticket with one ferg coin (after the stationmaster grudgingly sells you the ticket, a gust of wind comes along and blows it out of your hand) (score = 120)

e

take the ticket (again the wind blows the ticket away)

n

take the ticket (again the wind blows the ticket away)

n

take the ticket (again the wind blows the ticket away)

n

take the ticket (you finally get hold of it just as the train moves away from the platform)

run after the train (twice. You finally catch up with it. The guard extends a hand and hauls you aboard. He asks to see your ticket) (score = 130)

show the ticket to the guard

wait (the train comes to a halt)

w (a snow white unicorn grazes nearby)

put the saddle on the unicorn (he is turning slowly back into wood. You've got to bring him back to life)

mount the unicorn

doofer the unicorn (once again life flows

through his body. You and the unicorn ride into the air. After a brief flight, you settle on the parapet of the Castle) (score = 140)

dismount

d

e

n

e

remove the shoes

d

open the door

n (Xam is here)

look at Xam (his imprisonment and restraint by the manacles have badly affected him)

wake Xam (he realizes it's you and starts to shout "Free! Free! Free!". This wakes the gaoler who peers into the cell. He summons a guard who drops Xam off to Jannedor. He then hurls you against the dungeon wall and slams the door) (score = 150)

tie the rope to the manacle (it now keeps the hatch shutter open)

take the match then light it

light the candle with the match

put the candle in the glass

put the glass under the rope

n

wait (the candle flame burns through the rope. The inner hatch slides downward and simultaneously the outer hatch opens)

n (score = 160)

u

ne

open the door

e

e (a glass dome is in the room's centre)

examine the dome (it's a glass hemisphere
locked to a massive immovable base
with sliding plastic blocks)

examine the blocks (the arrangement of
blocks and lights looks like this:

: 1 8 5 :

: 6 9 :

: 7 2 3 4 :

This is a classic number puzzle
wherein you want to slide the blocks
so that the numbers in any row or
column sum to 15)

slide 5

slide 8

slide 1

slide 6

slide 7

slide 2

slide 9

slide 5

slide 3

slide 4 (the lights flash. The glass dome
shatters into hundreds of shards)
(score = 170)

take the bracelet (Fortunate you were
wearing gloves to protect your hands
from the glass fragments)

put the charms on the bracelet (score =
175)

w

w

sw

nw

u

u

open the left (right) door

n (score = 185)

examine the table (there is a crystal ball on
it)

take the ball (hopefully Jannedor has not
entered. If so, you are dead and must
restore back to the Hallway and try
again. If you want, you might try the
other door this time)

d

d

se

examine the fireplace (it has a hearth in it)

examine the hearth (it's spick and span)

u (in the chimney)

examine the ball (repeat until Jannedor
glances at the fireplace)

doofer the ball

drop the ash

wait (repeat until the claw of Jannedor
appears and, like a snake, writhes
around the chimney)

put the bracelet on the claw (you eventu-
ally wind up back at Neverending
Lane next to the bus stop)

inventory (the only things you now have
are a cheese sandwich and a herring-
bone coat)

look (you are run over by the bus. Con-
gratulations! You have died but have
indeed won the game) (score = 205)

King's Quest III: To Heir is Human Hints

The game begins with Manannan appearing and giving you an order such as:

Your kitchen is filthy! Go clean it, now!

Gwydion, my chamber pot needs servicing! Go empty it, immediately!

My office is dusty. Clean it at once!

You've been neglecting my chickens again, Gwydion. Feed them and quickly!

Obeys Manannan and do what he asks you to do. For example, if he wants you to clean his office, then go and get the feather duster on top of the oak cabinet in his study. You will automatically start dusting everything with it and then put it back on top of the cabinet.

General Hint

As you roam around, the wizard will eventually appear and say either he's going to bed or going on a journey. When this happens he will be gone for about 25 minutes. During this period of time, you can transport items that appear with an asterisk in your inventory. If you try to transport these items when the wizard is not away on a trip or awake, he will appear and ZAP you, thereupon either taking away these items or more seriously, killing you.

Teleporting with the Magic Map

When you click on the map in your inventory (status), any location you have been to already will be displayed. You may teleport to these by clicking on them, and then clicking on the teleportation icon. Those locations that you have not yet visited, will show up as blank squares on the map.

Learning and Casting Spells

All spells must be cast in the wizard's laboratory. You must first have in your inventory all of the necessary ingredients for the spell. Then, type: Open the Book to Page XX where "XX" is the page on which the spell appears in the book that came with the game, e.g., III, V, etc., and type in the step-by-step directions exactly as they appear in the book.

Knight Orc

Part I (Loosed Orc)

e

e (you wind up in a pile of garbage)

take the knife and cloak

wear the cloak

d

w

n

examine the flagpole

take the halyard (it's a silken cord)

e

look at the bar (underneath it is a spear)

take the spear

e

d

take the cask

u

w

w

nw

nw

throw the knife at the drawbridge (it
opens)

take the knife

n

n

take the chest

s

drop the chest (the weight of the chest will
hold the drawbridge open after you
leave)

n

n (you encounter the knight in white satin.
Don't hang around here)

u

u (you see in the distance the names of the
key locations in the game that you
must find)

d

d

s

s (leave the chest there for now)

s

w

sw (you encounter the green knight on the
green horse)

kill the horse with the spear (the beheaded
steed falls on the knight and for the
time being traps him)

take the reins

go to the beech spinney

take the mat (a key falls from under it)

take the key

tie the halyard to the reins (they join
magically into a coil of rope) (score =
20)

tie the rope to the roller

d

take the hawser and the bucket

u

take the rope

tie the hawser to the rope (score = 30)

nw

examine the gibbet

take the noose

tie the noose to the rope (score = 40)

w

put the mat on the hedge

n (note Rapunzel's long hair)

cut the hair

take the hair

tie the hair to the rope (score = 50)

s

sw

inside

take the washing line

tie the washing line to the rope (score = 60)

outside

go to the beech woodland

tie the rope to the signposts (it makes an effective trip-wire)

wait (a mounted hunter enters waving a lasso. He doesn't see the rope and is caught mid-chest and hurled to the ground. The hunter strikes at you with his whip and wields a deadly blow. As you lie there conscious, but unable to move, a valkyrie swoops down, picks you up, and deposits you in a vast chamber of bright clouds beyond Paradise Gate)

wait (repeat until you are beside Paradise Gate)

go to the beech woodland

take all

take the lasso

untie the rope

tie the lasso to the rope (score = 70)

go to the hornbeam tangle (outside castle)

n

unlock the chest with the key

open the chest

look inside the chest

take the gold standard

take the cord

tie the cord to the rope (score = 80)

go to the juniper scrubland

inside

examine the hermit (he is wearing a belt and some robes)

give the gold standard to the hermit (he takes it, turns his back on you, and then walks over to his trophy cabinet to put the gold standard in it)

hit the hermit (while he's not looking you hit him over the head and knock him out cold)

take the belt

tie the belt to the rope (score = 90)

outside

go to the rowan edgewood

examine the goat (it is tied up with a tether)

take the tether

tie the tether to the rope (score = 100)

nw

w

w

sw

s

s (on the viaduct - to the south across the chasm is a huge Orc's head carved of

rock. It's damaged nose holds a large metal ring over the gap in the viaduct) tie the rope to the spear throw the spear at the ring (the spear lodges itself securely in the ring. You swing on the rope, which is now hanging strongly from the spear, across the chasm and crunch into the far wall. When you pull yourself together, you discover that you are wearing a visor. You are advised to leave it in place. Answer "yes" when asked if you want to do so. You have completed Part I)

Parts II, III (Hordes of the Mountain King, A Kind of Magic)

take the silver loaf
s
read the inscription (it talks of a glow. You have just learned the "glow" spell) (score = 120)
e (it is dark. To see your way you must: Cast glow. However, use it sparingly since this spell will eventually wear out)
s
se
e (before you cast the glow spell)
read the writing (while the room is dark, you make out the word "COLD". You have just learned the "cold" spell) (score = 140)

w
nw
n
e
wait for Oink (if he is not already here)
examine Oink (he is wearing a steel helmet)
take the helmet (if he runs away, just follow him and take the helmet again)
n
e (you are on a landing below a flight of well-polished stairs)
wear the helmet
u (at the top of the stairs, an orc hits you over the head with a club. Fortunately, the helmet protects you from getting injured. You are now in a grassy kitchen)
examine the tray (on it is a rat pie)
take the rat pie and the knife and the sack
d
w
w (Grok is here. He takes the rat pie and drops the map) (score = 170)
take the map
go to the lake
examine the pedestal (on it is a great black book)
read the book (you are told that you can only read it once. Do you want to do that now?)
yes (you learn the "death" spell) (score = 190)
wait for druid (if it is not already here.

When it arrives, it kneels down by the lake and breathes on its waters, which instantly becomes smooth and sparkly. In its depths, you see the word "CHARISMA". You have learned the "charisma" spell) (score = 210)

rainbird, tell me about the perch (he tells you that to help seekers after knowledge such as yourself, it is inscribed with the name of the LOCATE spell. You have learned the "locate" spell) (score = 230)

go to house (you are outside a spooky-looking house. As you enter the house it will be dark. Thus, in order to see, you will have to "Cast glow" in each room)

e

n (in brown study)

cast cold at fire

examine the grate (it is embossed with the word "EYE". You have learned the "eye" spell) (score = 250)

u

s (a mouse is usually here. If not, wait for it. You want to catch the mouse. Proceed as follows)

look under the bed (you see a small mouse hole)

close the door

put XXX in the hole (where "XXX" is any inventory item)

catch the mouse (it will disappear into a crack in the wall)

wait for mouse (it will reappear)

put YYY in the crack (where "YYY" is any inventory item)

catch the mouse (it will disappear into a crevice in the wall)

wait for mouse (it will reappear)

put ZZZ in the crevice (where "ZZZ" is any inventory item)

catch the mouse (since there are no longer any exits for the mouse to escape, it runs around the room in circles looking for a place to hide)

drop the sack (the mouse will run into the sack) (score = 280)

take the sack

take XXX and YYY and ZZZ (the mouse will start squeaking. It is trying to communicate with you but is talking to fast for you to understand it)

cast eye on hole (a floating eye appears nearby)

eye, enter the hole (the eye in the mouse-hole sees a glittering card)

take the card

n

n (upstairs bedroom)

wait for ghost

follow ghost (it will eventually come back to the upstairs bedroom and wave its shimmering arm over the western wall causing an opening to appear in it. It will then lead you into a secret room through this opening)

take the bones

give the bones to the ghost (if the ghost leaves, then follow it and it will eventually return here and take the bones from you. When, this happens, the bones will form themselves into the word "SLOW". You have learned the "slow" spell. Instead of using up your one allowed reading of the black book on the pedestal at the lake to learn the "death" spell, you could now: Cast slow at mouse. This also gives you the "death" spell and lets you save the reading of the black book for another spell later on) (score = 300)

stop following ghost

go to archway

e

cast glow (you will usually meet the dragon here)

wait (repeat until someone shows up and tries to sneak behind the dragon. The dragon will crush him (her). The dragon will then lumber forward to attack. Not noticing the mouse, however, the dragon will get bitten by it) (score = 330)

e

s

e

e

s (in a stone-lined room)

take the scale

go to archway (wait there for a human to show up, e.g., Sam the Grey Earl)

cast death on Sam (or whoever it was that showed up)

give card to Sam (this is your way of getting the card into Paradise)

wait for Valkyrie (she will take Sam when she arrives)

follow Valkyrie (you will get as far as the glowing gate)

cast death on me (the Valkyrie will show up (if not wait for her), pick you up and drop you in the middle of a pink cloud. You should see the Valkyrie and Sam)

take the card from Sam

remove the visor (your world shifts and starts to resemble a huge warehouse)

look (you are sitting in a repair shed.

There is a closed door to the east)

open the door (you can do this since you have the glittering ID card in your possession)

e (you are in a poorly lit room. Casting the glow spell here will do no good) (score = 370)

take the reprogrammer (you don't get any acknowledgment of having done this. However, if you now check your inventory, you will find it listed there. The reprogrammer is the "recruiting device". You must use it to recruit the mouse, dragon, troll, and rainbird. Shortly thereafter, you will be thrown back out to the glowing gate)

wear visor

take all (of the possessions you left behind before you entered Paradise. If you now check your inventory, you will find that the reprogrammer is called a "peculiar mechanism")
go to rose garden
take the marrow and the garlic
w
cast glow
close the door (on the back of it is a note)
take the note
read the note (it is torn from a fertilizer packet. Only the word "GROW" stands out clearly. You have learned the "grow" spell) (score = 390)
cast grow on marrow
read marrow (it is now a champion; it is bloated and on it are great white letters spelling out "CURE". You have learned the "cure" spell) (score = 410)
go to graveyard
drop the sack
s
wait (for some human character to show up here)
s (the human character will usually follow you in here. If not, restore back to the necropolis and try again)
cast glow (there is a vampire here and a half coin)
take the coin
wait (the vampire will descend and feast on the human you brought in. He thanks you for this and in return

teaches you the magic "knives" spell. Also, he will open the door to the north allowing you to leave) (score = 430)

n

n

examine the gravestone (inside it is a recess)

drop the coin

recruit the mouse (score = 460)

mouse, stay here, wait 1, put coin in recess

s

wait 1 (repeat until the tomb opens)

look inside the tomb (inside it is a stone slab inscribed with the word "DE-

TECT". You have learned the "detect" spell. The tomb closes)

(score = 480)

n

take the sack

go to marsh

find the frog

kiss the frog (it spits and wipes its mouth in disgust)

look (you see a smooth pebble that

apparently was spit up by the frog)

examine the pebble (it is carved with the single word "JUMP". You have

learned the "jump" spell) (score = 500)

go to archway

e

e

cast glow

cast jump east
cast glow (you are in the salt mine. Carved into the salt is the word "SWORD". You have learned the "sword" spell) (score = 520)
cast jump west
cast glow
take all
go to archway (now roam around and find and take about 10 silver treasures. each time putting them in your sack. Then return here)

w

w (a troll appears and won't let you on the bridge. Just north of the bridge is a door leading to the troll's lair that is locked with three bolts. In order to open that door and get into the lair, you must lure the troll far enough away from this location and then drop all remaining treasures and run back to the bridge. The procedure for doing this is simple in concept but extremely tedious to accomplish in the actual game play. You will have to save the game continuously along the way as you make progress through the sequence until you actually succeed. The idea is that you allow the troll to steal a silver treasure from you. Then move one location away and wait for her to arrive and steal another treasure. Continue to do this until you are about six or seven locations from here. The

problem is that other characters show up as you move away from the bridge and also steal treasures from you. That's why it is best to keep them hidden in the sack and take them out one at a time. The specific sequence resembles the following. For simplicity of explanation, we shall refer to the silver treasures as A,B,C,D,....Also, we shall assume that you just move continuously south although any other set of directions is equally appropriate)

remove the A (from the sack)
wait 1 (repeat until the troll steals A from you)

s
remove the B
wait 1 (repeat until the troll steals B from you)

s
remove the C
wait 1 (repeat until the troll steals C from you)

s
remove the D
wait 1 (repeat until the troll steals D from you)

s
remove the E
wait 1 (repeat until the troll steals E from you)

s
remove the F

wait 1 (repeat until the troll steals F from you)

s

remove the G

wait 1 (repeat until the troll steals G from you. Remove and drop any remaining treasures including the glittering card)

run to bridge

open the door (three times. If the troll shows up, you must go back and try it again)

n (score = 550)

take the wallet

cast glow (you are in the troll's lair)

wait (the troll will immediately show up if she has not already entered. She is horrified to find you inside and see that you have her wallet. She suddenly turns sweet and tries to entice you to return her wallet to her in exchange for information regarding where you can find a treasure beyond price)

No (having refused her request, she exclaims that life is hardly worth living without her wallet and offers to help you if recruited)

recruit the troll (score = 580)

troll, follow me

s

troll, wait 1, pull the rope out of the water
pull the rope out of the water (along with it comes a ring)

take the ring

examine the ring (it has faint marks around the edge. Unfortunately, you cannot discern their meaning)

go to house

e

n

cast glow

throw ring in fire (the word "EXORCISE" shines brightly from the inside edge. You have learned the "exorcise" spell) (score = 600)

troll, follow me

go to archway

w

cast exorcise on driftwood

read driftwood (carved on it are the letters of the word "FLY". You have learned the "fly" spell) (score = 620)

go to rose garden

troll, catch the apple

shake the tree (the troll catches the rotten piece of fruit)

examine the apple (blotches on it make up the word "EMPATHY". You have learned the "empathy" spell) (score = 640)

cast fly on statue (it is flying)

examine the statue (underneath it is the word "SHIELD". You have learned the "shield" spell) (score = 660)

go to archway

e (the dragon should be there. If not, wait for it)

give scale to dragon

recruit dragon (score = 690)	cast knives on rope
dragon, go to mud	cast shield on me
follow dragon	s
cast cold at mud (this freezes the mud and prevents the Demon from trying to pull you under)	cast glow (continue to do this as you travel through the dark castle rooms)
dragon, wait 1, clean the plaque	cast fly on me
clean the plaque (you rub the plaque. Then the dragon rubs the plaque (either of you alone could not have cleaned off the rust on it). It is now readable and says: "Fed up with books? It's child's play to burn them with a FIREBALL. You have learned the "fireball" spell) (score = 710)	s (you are over a pool of acid. You see a button)
dragon, follow me	cast sword on button (a broadsword appears in your hand)
troll, follow me	push button with broadsword (the door swings open)
go to lake (make sure the troll and dragon are with you. Sometimes, you have to ask them again to follow you since they have a tendency to drop behind on the way here)	s
troll, wait 2, kill the ants	w (a jailor puts a ball and chain on you. You can still move about the castle, however)
dragon, wait 1, kill the ants	n
kill the ants (the three of you together kill them all)	n
take the amber	take armour and scabbard
examine the amber (a tacky ornament in its centre is shaped like the word "MAGICIAN". You have learned the "magician" spell) (score = 730)	examine scabbard (in it is a dagger)
go to castle (make sure the troll, dragon, mouse (in sack) and rainbird are following you)	examine dagger (it is inscribed with "TELEPORT". You have learned the "teleport" spell) (score = 750)
	s
	s
	e
	e
	wear armour
	open door
	n
	cast fireball
	tell fireball to attack the scrolls (the fireball nods and then explodes. The scrolls catch fire and the monk makes a hasty retreat)

n

examine the panel (it is a lump of wood inscribed with "LIGHTNING". You have learned the "lightning" spell. Alternately, if you hadn't previously read the black book to learn the "death" spell, but instead learned it by casting the slow spell on the mouse, then you could now read the book and learn the "lightning" spell) (score = 770)

go to courtyard

cast grow on ball and chain (the leg-iron grows and you step out of it whereupon it shrinks again)

n

go to lake

cast magician on me (since you have learned all 21 spells, you are now qualified to become a magician)

recruit rainbird (score = 800)

go to marsh

se

e (north of exit ramp. Make sure the troll, dragon, mouse, and rainbird are with you. If not go find them and tell them each to: Go to Exit)

troll, go south

rainbird, go south

dragon, go south (his smoke sets off an alarm causing the emergency exit to open)

s

troll, go west

rainbird, go west

w (you are in a chequered corridor, marked "NO ROBOTS". You see an inspection hatch above you. You are too short to reach it)

troll, open the hatch (inside is a bundle of wires but they're too far away for the troll to break them)

troll, put the mouse into the hatch (repeat until the mouse attacks the wires and the force field disappears)

troll, go west

rainbird, go west

w (you are in a simrock foyer. You see a plastic kiosk. The cashier sees you and pushes a button by the side of her desk. The entrance door to the west swings shut and the cashier rushes out the door on the far side of the cubicle) (score = 900)

examine the kiosk (inside it is a button to open the door between you and the outside world. The opening (window) is too small for you to fit through)

rainbird, in, push the button (the Rainbird squeezes through the window and pecks the "open" button. The main door opens and you and your allies escape through it. You now have an opportunity to make a great new future in the outside world provided you can escape the police who are arriving to investigate the fire alarm. But this is a problem for the next game. For the moment, you have won brilliantly!) (score = 1000)

Leisure Suit Larry: The Land of the Lounge Lizards

Outside Lefty's Bar

Read the sign (on the pole). It says "Taxi Stand".

Inside Lefty's Bar

Order a glass of whisky at the bar. (Note that you don't automatically drink it. Had you ordered either wine or beer, you automatically drink it and don't get a chance to carry it with you) (1 point).

Dimly Lit Hallway

Take the rose (from the table) (1 point). Give the whisky to the drunk. He gives you a TV remote control (2 points).

Restroom

Read the walls (Keep doing this until you get an interesting message: "The password is" 'Ken sent me.'" (2 points). Use the facilities while you're in there. Sit down (on the toilet) (1 point). Stand up. Examine the sink. Take the diamond ring (3 points).

Inside Lefty's Bar

Knock on the door on the right. When asked for the password, type: Ken sent me.

Storage Room

To get upstairs, the pimp wants \$100.00. You don't have enough money since you started with \$92.00 and have already spent \$3.00 for the shot of whisky so you must either find a way to get some more money (like gambling in a casino) or figure out a way to get the pimp away from the stairs. Here is the other way. Move in front of the tv and type: use the remote control. A boring soap opera will appear on the screen which is of no interest to the pimp. (3 points). Change the channel (repeat until you get to a sex-oriented show that is of interest to the pimp. He will then leave the stairs to come and watch it) (8 points).

Hooker's Bedroom

Take the candy (from on the table) (2 points). Open the window. Climb through the window.

East Alley

Move to the left and fall off the platform into the trash bin. Look in the trash bin. Take the hammer (3 points).

Outside Lefty's Bar

Move in front of the taxi stand (about two sidewalk tiles to the right of the pole) and type: call a taxi. Walk directly to the rear door type: enter cab. When he asks you where

you want to go, type: casino. When you get there, talk to the driver. He will tell you of other places to go in town, e.g., all-night wedding chapel, convenience store, disco. Then, pay the driver. Get out (1 point).

Inside Casino

Play blackjack and/or slots until you accumulate \$250 (this is the casino bank's limit).

Entrance to Cabaret Lounge

Examine the ashtray. Take the card (1 point). Examine the card (it's a pass to get into the Lost Wages Disco).

Cabaret Lounge

The only table that is not reserved is the one on the right at the rear. Sit down (1 point) and watch the entertainment for a while. When you leave (or perhaps before you entered) the casino you will be approached by a poor man (who emerges from behind the bush on the right) to buy an apple. Buy an apple (for \$1.00) (3 points). Call a cab and go to the disco.

Outside Disco

Show the card to the bouncer (5 points).

Inside Disco

Sit down (at the table where the girl is) (1 point). Look at the girl. (1 point). Talk to the girl (1 point). Use the breath spray. Talk to the girl. (Repeat until she tells you here name is Fawn). Talk to Fawn (repeat until she asks you for a present). Give the candy to Fawn (5 points). Give the ring to Fawn (5 points). Give the rose to Fawn (5 points). Dance with Fawn. (The dance floor lights up as Fawn heads onto it. Stand up and follow her onto the dance floor. At the end of the dance exhibition between the two of you, she will return to the table) (5 points). Go back to the table and sit down. Look at Fawn. Talk to Fawn. (She makes you a marriage proposal). Pay Fawn (\$100) (7 points). Stand up.

Convenience Store

Step up to the counter and buy a condom. After a series of questions (some of which are ridiculous), you will get what you asked for (4 points). Go to the magazine rack and take the magazine (1 point). Go back to the counter and pay the clerk. Look at the magazine — you see an article about how professional window washers secure themselves to buildings with a rope around their waist — a clue how to get the bottle of pills on the window ledge) (1 point). Walk to the left of the rear wall, and take the wine (from the shelf) (1 point).

Outside the Convenience Store

You will be approached by a beggar. Give the wine (from the convenience store) to the

man. In return, he gives you a knife (5 points). Look at the pole (you see the numbers: 555-6969). Dial the telephone (5556969). After a series of questions, they will hang up on you (2 points). Call a cab and go back to the casino. Play a little more blackjack and/or slots until you have about \$175 in your possession.

Outside Wedding Chapel

Look at the flasher (near the pole on the right). Talk to the flasher (1 point).

Inside Wedding Chapel

Marry Fawn. (The minister will take another \$100 from you. You get 12 points at the end of the ceremony). Then, go to the fourth floor of the casino (the room with the cracked heart on it).

Honeymoon Suite

Talk to Fawn. (She wants some wine). Turn on the radio. (The broadcast will be interrupted and you will learn of a phone number to call for wine delivery. It is 555-8039) (1 point).

Outside the Convenience Store

The phone will ring. Answer the phone. (Fawn will talk to you. You get 5 points at the end of the conversation). Dial the telephone (2096836858 - this is Sierra On-Line's number. You get 5 points at the end of the message). Dial the telephone (5558039). Ask for wine to be delivered to the honeymoon suite of the casino (5 points).

Honeymoon Suite

Take the wine. Look at Fawn. Get in bed. (Instead of the implied sex act, she ties you to the bed and then leaves). Cut the rope with the knife (10 points). Take the rope (3 points). Go down to the casino. Depending on how you handled the pimp, you might need to play some more blackjack and/or slots and accumulate some money. Take a cab back to the bar.

Storage Room

Pay the pimp (\$100) unless you previously distracted him with the TV.

Hooker's Bedroom

Move around to the left side of the bed and type: strip. Wear the condom (10 points). Get in the bed (You get 11 points at the end of the sex act. Had you had sex with the hooker without using a condom, you would shortly thereafter contracted a fatal illness and died). Remove the condom (1 point). Climb through the window.

East Alley

Look at the east window (you see a bottle of pills). Move to the right of the fire escape and tie the rope to the fire escape. Tie the rope around the waist. Take the pills (they

are behind a locked window). Break the window with the hammer (8 points). Take the pills. Grab the fire escape. Untie the rope.

Entrance to Cabaret Lounge

Enter the elevator (from the rear) and type: press eight.

Eighth Floor Lobby

Approach the desk at the right front of the room and look at the security guard. Talk to the woman (after repeating this a few times you will find out her name is Faith). Talk to Faith (repeat until she tells you: "You're a man of the world, Larry. Perhaps some sort of medical stimulant would help." Give the pills to Faith. (5 points). Look at the desk. Push the button. Enter the open penthouse elevator doors on the right (5 points).

Penthouse (Bedroom)

Open the door and then enter the closet on the right. Look. Take the doll (5 points). Inflate the doll (5 points). Use the doll (twice) (8 points). (The doll flies away leading you to the lady in the hot tub).

Penthouse (Spa Deck)

Approach the spa and type: strip. Look at the woman (repeat until she's waiting for you to determine what it is she wants). Give the apple to the woman (15 points). Eve will then lead you out of the spa and into the bedroom (25 points). Watch the grand finale.

Plundered Hearts

You start out lying in a bed in a cabin aboard the Lafond. What actions you take until you are rescued from this ship and brought to the Helena Louise (two days later) are inconsequential to the remainder of the game. Thus, you can try various responses to the action that is taking place, or, if you want, you can just continue to type the command: "wait" until the above takes place. I will begin the solution in the Captain's Quarters of the Helena Louise where you are lying on the bed.

stand up

wait (repeat until Jamison leaves)

n

open the cupboard

enter the cupboard

take the clothes

(score = 1/25)

n

d

n

look at the fence (notice the 6 inch gap over the closed gate — Jamison should appear, pin a jewelled brooch on your clothes, and hand you the coffer that was under the bed in the cabin on the Lafond Deux)

n

take the bottle and the mirror

(score = 2/25)

s

look inside the cage (you should now see a burning fuse near the pile of gunpowder kegs)

s

u

s

examine the coffer (the lock on it is now smashed. Had you examined it in the cabin on the Lafond Deux, you would have found that it was locked)

open the coffer

take the invitation

examine the invitation (it's an invitation to a ball!)

throw the coffer through the window

(score = 3/25)

sit on the ledge

remove the frock

wear the shirt

wear the breeches

grab the ladder

u

u

u

u

(score = 4/25)

n

n

examine the barrels

rip the frock (you tear out a rag from it)

examine the frock

dip the rag in the water

open the hatch

d

throw the rag over the gate (this extinguishes the burning fuse and prevents the ship from exploding)

(score = 5/25)

u

n

look at the winch

read the lever

move the lever up

(score = 6/25)

enter the shack

take the dagger (note that the tide has turned with the ship now drifting a little way back toward the island — this will allow you to reach the island when you escape shortly)

e

s

s

look at the casks

enter the cask

cut the line with the dagger (you and cask are thrust into the sea — you wind up in a lagoon)

(score = 7/25)

take the pork

wait (repeat until the current pulls you in towards the island and the cask lodges itself in the sand)

get out of the cask

w

n

w

n

e (Lucy is here in the kitchen — make sure you are wearing your shirt and breeches and not your torn frock before entering here)

wait (Lucy offers you a garter)

take the garter

w

s

ne

u

take the gown

remove the breeches

remove the shirt

wear the gown

(score = 8/25)

n

e

d (the butler is here)

wait (he will ask you for an invitation to the ball)

give the invitation to the butler (If you never opened the coffer and took it, you can instead: bribe the butler with the banknote).

(score = 9/25)

s (in the ballroom)

wait (until Jamison is through dancing with you and leaves — note that he talks about a secret passage in the library)

wait (you are asked to dance by a man with a French accent — it's Lafond. He threatens to kill your father if you turn him down)

dance with the man

wait (he tells you that when he is ready, the butler will summon you to sup with him in his room. Lafond then leaves)

(score = 10/25)

e

n

n (in the library)

look at the portrait (it depicts Jean Lafond in exactly the same pose as on the 50 guineas banknote that came in the game package. Examine this carefully for clues as to how to proceed. There are three parts to the puzzle associated with discovering the secret passage here in the library)

look at the bookshelves

move the treatise (part one of the puzzle)

(score = 11/25)

take the hat (part two of the puzzle)

look at the globe

press St. Sinistra (part three of the puzzle — the portrait pops open revealing the passage)

(score = 12/25)

n

d

e

e

take the powder horn and the key

(score = 13/25)

examine the powder horn (it's filled with a mixture of gunpowder and shot)

w

w

s (in the anteroom — there are two possible solutions to get past the crocodile)

Solution #1

examine the bottle

read the label

squeeze the drops on the pork

throw the pork at the crocodile

wait (repeat until he falls asleep)

(score = 14/25)

Solution #2

throw the pork at the crocodile

put the garter on the jaws

(score = 14/25)

s

w

unlock the door with the key

open the door

n (you find your father)

(score = 15/25)

wait (he suggests getting out of this maze)

s

e

n

n

u

s

s (this move actually is equivalent to "south" and "west" since you wind up in the foyer)

wait (repeat until the butler tells you that Lafond requests your presence in his room)

u

e

open the door	yes
n (in Lafond's bedroom)	e
(score = 16/25)	n
drink the wine (in the blue goblet)	n
pour the wine into the green goblet	open the portrait
squeeze the drops (in the bottle) into the	n
green goblet	d
examine the spices	s
wait (Lafond will ask you if the green	s (this time Cookie takes care of the
goblet is his. Since you suspect that	crocodile allowing you to cross)
he is aware of what you have done,	take the rapier
and that because of this is likely to	stab Crulley with the rapier (twice)
pull a switch of the goblets on you,	(score = 20/25)
answer him in the negative)	close the trapdoor
no (indeed he now makes you drink from	give the smelling salts to the captain
the cup he thinks was intended for	(score = 21/25)
him, i.e., the blue goblet)	unlock the manacles with the brooch
drink the wine	(score = 22/25)
wait (Lafond will start to caress your neck)	n
take the spices (note that Lafond lays	n
everything you carry on the floor —	u
i.e., you lose your inventory)	s
blow the spices at Lafond	s
(score = 18/25)	w
take the garter and the powder horn	u
look through the window	e
shine the mirror in the moonbeam	s (in the gallery)
(score = 19/25)	untie the rope
s (the butler is lying on the floor asleep)	swing on the rope (you slam into Lafond
w	and knock him apparently uncon-
d	scious)
s (in the ballroom)	(score = 23/25)
wait (your signal to the ship did some	take the garter and horn
good. Jamison's men and Cookie	s
have shown up. Cookie asks if you	s
know where to find the captain)	

s (at the beach. There are 4 possible endings to the game each achieving a different title upon completion. Which of them you are able to complete depends to a certain extent on how you solved previous puzzles and what items you carried along in your inventory until this point)

Solution #1

take the stone (the small pointed one below your foot in the water)

put the stone in the garter (Jamison challenges Lafond to a duel. Lafond agrees under the condition that if he should win, you will then come to him. He asks for your decision)

(score = 24/25)

yes

wait (repeat until Crulley moves down the stairs)

sling the stone at Crulley (you win and earn the title of "Orphan")

(score = 25/25)

Solution #2

wait (repeat until Jamison challenges Lafond to a duel. Lafond agrees under the condition that if he should win, you will then come to him. He asks for your decision)

yes (Lafond drops his pistol)

take the pistol

pour the gunpowder into the pistol (Crulley moves down the stairs)

(score = 24/25)

shoot Crulley with the pistol (you win and earn the title of "Happily Ever After")

(score = 25/25)

Solution #3

e

enter the skiff (you hear that Jamison challenges Lafond to a duel. Lafond agrees under the condition that if he should win, you will then come to him. He asks for your decision)

yes

row to the Helena Louise (you win and earn the title of "Pirate Queen")

(score = 25/25)

Solution #4

wait (repeat until Jamison challenges Lafond to a duel. Lafond agrees under the condition that if he should win, you will then come to him. He asks for your decision)

yes (Lafond drops his pistol)

take the pistol

pour the gunpowder into the pistol (Crulley moves down the stairs)

(score = 24/25)

fire the pistol into the air (The pistol shot scares Crulley who fires his pistol and kills you instead of Jamison. Unfortunately, you have died but nevertheless you win and earn the title "Love Transcending Death")

(score = 25/25)

Police Quest

Hallway

Items present: Keyboard, table holding radio extenders (they work in conjunction with your police car radio when you are not in the patrol car), photograph of Lytton's chief of police Randolph "Brown Nose" Whipplestick "01 B.N.", barred window to evidence room. Take the radio extender (2 points). Take the keys (for the patrol car. They are on the left wall) (1 point).

Locker Room

Go to the 2nd (from the entrance) row of lockers and nearest to the bench (furthest from the shower). Open the locker. Look inside the locker. You find: your weapon in your gun belt, a speed loader of ammunition, your briefcase, the keys to your Corvette, a towel, your civilian clothes, and an old T-shirt and pair of jeans. Take all (the ammunition, weapon and gun belt, and briefcase) (2 points). Open the briefcase. Look (in it are: a pen, a notebook, and your LPD ticket book). Take all. Close the briefcase (6 points). Close the locker.

Briefing Room

Take the newspaper (on the rear right table) and read it. (You turn the pages with the horizontal arrow keys) (5 points). Put paper down. Find your place (at the left of the desk on the right nearest the podium), face front, and wait for the briefing from Sgt. John Dooley (4 points). Dooley states that you're looking for a stolen black 1983 Cadillac license number LOP1238, VIN C03456218. Also, you learn that 3 teenagers were arrested separately each for drunk driving. Two of the three were in possession of cocaine, and all attended Jefferson High School. Your (Sonny Bonds') call number is 83-32 (4 points). Write notes (When you get the "Note" prompt, type whatever you want. At the end, write: Finished) (1 point). Go over to the wall on the right with the pigeonholes. Look in the pigeonhole (nearest to the rear of the room) (1 point) You see a note that says: "Sonny: How's about a 11-98 at Carol's Caffeine Castle later in the shift? Signed: Steve" (1 point).

Side Hallway

You see a table with a blank memo pad and "in" basket where you submit your reports and memos.

Parking Lot of Police Station

Approach the PD car on the left opposite your Corvette. Walk around the car until you are informed that you've performed the necessary walk-around safety check of the vehicle (5 points). Open the door. Enter the car. Close the door. Look (you see a

nightstick in a holder on the driver's door panel). Take the nightstick (3 points). Start the car. (You now see a map of the city displayed on the screen).

On the Streets of the City

You ride around town a bit and you will eventually be summoned on the radio to respond to an 11-83 at the southwest corner of Fig and 4th.

Southwest Corner of Fig and 4th

You see a green car that has gone through the brick wall of Colonia Van and Storage Inc. (3 points) Go around to the car and: Examine the man (twice). You decide that the man who is slumped over the wheel was indeed murdered. Approach the people standing around on the street. Talk to the people. One of them is excited and will approach you. He tells you that he was witness to the accident and saw the other car drive away. It was a light blue Cadillac. Talk to the man. He tells you that part of its license was L964 (Not the stolen car you are looking for). Go back into your patrol car and radio headquarters (twice). You are told that Sgt. Dooley and detective Hamilton are on the way to take over the investigation. When they arrive, you can leave and go back out on the streets and find the rat who's responsible for the killing (5 points).

On the Streets of the City

You ride around town a bit and you will eventually be summoned on the radio to respond to an 11-98 at Carol's Caffeine Castle.

Carol's Caffeine Castle

You arrive at the castle (3 points). Your partner is seated at the table on the left. Approach the table and: Sit down. Carol will eventually come over and serve you. Eventually the phone will ring. Carol will answer it and call you over telling you that Hamilton is on the phone. Stand up. Approach the phone and: Talk to Hamilton. He tells you that the victim in the car was Lonny West, a local small-time drug dealer (2 points). Leave the castle and go back out on the streets.

On the Streets of the City

You ride around town a bit and you will eventually be told that you are just aching to write a ticket. Soon after, you will notice a red sports car run a red light (I noticed this at the corner of Rose and 7th). Turn on your siren and follow the red car. Eventually, the driver will pull over to the curb and stop (4 points).

Curbside with the Red Sports Car

Open the briefcase. Take the ticket book. Take the pen. Close the briefcase. Exit your

car and approach the driver. Examine the driver. Talk to woman (it's Helen Hots. She takes out her license and gives it to you. She asks you your name). Sonny Bonds. (She apologizes for having run the red light and asks if there is anything she do for you to condone for her misdoings). No. (If you say yes, she will give you her number: 555-4369 and you will only score 1 point and the scene will be over. This is not the right course of action). Write ticket. Return license. Ask woman to sign ticket. Give ticket to woman (7 points). Return to your patrol car and radio headquarters. You ask for a run on Ocean, Henry, Mary, Yellow, Mary, George (OH MY MG) and find out that it is indeed registered to Helen Hots (1 point).

On the Streets of the City

You ride around town a bit and you will eventually be summoned on the radio to respond to a complaint at Carol's Caffeine Castle.

Carol's Caffeine Castle

Talk to Carol. Carol tells you that you must go next door to Wino Willey's and get the men to move their motorcycles away from the front of her shop as they are taking up all the parking spaces (3 points).

Wino Willey's

Approach the men and: Talk to the men. You are told that the one in the black leather jacket is the leader who then approaches you. After some conversation, the men surround you and are about to be accosted when you: Hit the men with the nightstick. They all leave peacefully (5 points). Talk to the girl. Do you have information about drugs? (3 points). Return to your patrol car and radio headquarters. Then go back out on the streets.

On the Streets of the City

You ride around town a bit and you will eventually observe an erratically-driven vehicle - one where the driver had one too many. Turn on your siren, follow the vehicle, and pull it over to the curb (3 points).

Curbside with the Drunk-Driven Vehicle

Approach the car and: Examine the driver. He is clearly intoxicated. Get out (don't block his door or he will ask you to move). Smell breath. Give FST (Field Sobriety Test) (3 points). Handcuff man (he asks to be handcuffed in the front saying he doesn't feel too well). No (You explain that it is not proper procedure to handcuff in front. You arrest him in violation of Code VC23502 - driving under the influence). Read rights. Follow me (3 points). Approach the patrol car and put the drunk driver in the back seat. Radio headquarters to run a check on personalized license plate PRGRMR1.

You find out that it is registered to Art Serabian. He has two prior DV1 convictions) (1 point). Take him to jail.

Outside Jail

You order the drunk out of your car and up the stairs. Follow him up the stairs. Open gun locker (to the left of the door). Put gun in locker (2 points). Close gun locker. Push buzzer (to the right of the door). Take the prisoner inside.

Inside Jail

You and your prisoner are greeted by the jailer. He asks what he can do for you. Put Art in jail. You are asked what you are charging him with. Drunk driving. You remove and inventory the prisoner's personal property then hand it to the jailer with the booking slip. The jailer takes this stuff and orders the prisoner's handcuffs be removed and that he be placed behind door number one. Remove handcuffs (2 points). (Had you not checked your gun outside, the prisoner would have knocked you out cold). You proceed to put Art in cell #1. On the way out, Laura enters the jail and tells you about a position opening in the Narcotics Division which, according to Lt. Morgan, will be filled by a veteran street cop. If you're interested, submit a memo to Lt. Morgan as soon as possible. The jailer tells you to get back to the office on the double. Leave the jail and pick up your gun on the way out.

Parking Lot of Police Station

Leave your nightstick in the car.

Side Hallway

Approach the table. Write memo (requesting transfer to Narcotics Division). Put memo in basket (2 points).

Hallway

Dooley is ranting and raving "If that 'Gremlin' keeps messing with me, I'm going to notify Internal Affairs to start an investigation. When I find out who the little weasel is, you'd better believe that he or she will be walking a footbeat from the river all the way to Joe's junkyard". Dooley suggests you look in his office to help him shed some light on how a certain creature made its way to the top of his desk.

Dooley's Office

A full-grown chicken with its legs tied together is flapping about right on Dooley's desk. Examine the chicken. Talk to Dooley (He talks more about the 'Gremlin'). Leave the office.

Hallway

You are off duty. You get an invitation from the other officers to a party to be held at the Blue Room for your friend Jack.

Locker Room

Open the locker. Take the towel. Close the locker. Go and take a shower. (Remember to: Turn off the water when you are through; else, you will lose a point). Return to your locker. Open the locker. Take clothes (this time you put on your civilian clothes). Take keys (to your Corvette) (3 points). Close locker. Go to the parking lot. On the way out: Put radio (extender) on table. Put patrol car keys on keyboard (on wall in Hallway).

Parking Lot of Police Station

Look in the car. Take the wallet (3 points).

Blue Room

You arrive at the entrance to the Blue room (2 points). Inside, Jack is seated alone at a table. Sit down (in the chair to Jack's left (your right)). Jack starts to tell you about the day he's had. He discovered that his daughter is doing drugs. He knows she's getting 'em at school but he can't finger the punk who's supplying. He goes on talking about how his life is a mess. In comes Keith who sits down in the other chair. Suddenly, the birthday party begins which includes a cake celebration and a balloon-carrying hula girl (Hoochy Coochy Hannah). When the party's over, Keith reminds you that you are due at the station for a swing shift briefing in 15 minutes (2 points). Head back to the station.

Locker Room

Open the locker. Take towel. Close locker. Go and take another shower. Return to your locker. Open the locker. Take clothes (your patrol uniform again). Take all. Open the briefcase. Take all. Close the briefcase. Close the locker.

Briefing Room

Take your seat in your position at the front right table. Dooley speaks: "Men, we've received information from the Day Sergeant concerning a Missing Persons report filed earlier this morning. It seems that a Mexican male (physical description of 5' 8", 145 lbs, black hair, brown eyes) by the name of Jose Martinez was last seen by his wife two days ago getting into a late-model light blue Cadillac (no doubt the one that was seen by the witness at the green car accident). No one has seen or heard from Martinez since. This person has some previous arrests, involving narcotics sales. Be advised that the black Cadillac may be one and the same as the one involved in the recent murder of Lonny West. We have a partial license plate number of 'L964'" (1 point). Write notes (Type: Finished when you are through jotting down your notes). Go over to the wall with the pigeonholes. Look in the pigeonhole. You find a sealed envelope which contains a message from an unknown informant advising you of illegal, high stakes gambling in the back room of the Hotel Delphoria Cocktail Lounge (3 points). Go back out on the streets. Don't forget to

pick up your radio extender and patrol car keys on the way out. Then give your car a safety inspection before getting into it.

On the Streets of The City

You ride around town a bit and you will eventually be advised on the radio of a possible stolen vehicle in your vicinity. The vehicle is a light blue, late-model Cadillac, last seen near Jefferson High. Possible drug involvement. After you spot the car, turn on your siren and pull it over (5 points)

Curbside with Light Blue Cadillac

Use your radio and call for backup Code-3. Wait (with the door closed) until Jack Cobb arrives. He tells you he will cover you from the passenger side of your vehicle while you make contact with the suspect. Wait until he is in place. Open the door. Get out. Stay behind the car door for protection, i.e., don't close the door while Cobb inches up on the other side of the car. Draw gun. Load gun with ammunition (4 points). Get out (the punk exits the car and approaches you). Put your hands up (2 points). Lie down. (2 points). Approach the suspect. When you get to him: Put gun in holster. Handcuff suspect. Stand up. Search suspect (you find some change and a loaded Smith and Weston, 45-caliber semi-automatic handgun. The suspect claims to be carrying the gun only for self-defense on the freeways. You tell Cobb to book this for evidence (2 points). Read rights (1 point). Follow me. Put the suspect in the rear of your patrol car. Go over to Jack and: Look at gun (you see a picture of the gun). Read serial number (SW9764912) Give gun to Jack (4 points). Time to search the suspect's car. Walk over to the open door on the driver's side and: Look at the door (the doorjamb is black instead of light blue - a paintjob). A closer inspection reveals the vehicle's VIN plate C03456218 (2 points). Search the car. Open the glove compartment. Look (you observe a black notebook, and two driver's licenses. Open the notebook. In it is written: \$2,000.00 col. R.G. Set up H.D. gambling (obviously H.D. stands for Hotel Delphoria) blackjack Initiate plan for dealer R.O. meet J.M. and L.W. Cindy \$100.00. Close notebook. Examine driver's license. They belong to Marvin Hoffman (the suspect) and Leroy Pierson (the alias). Close glove compartment (4 points). Walk around to the rear of the car and: Open trunk. Look (you discover a clear plastic bag containing a white powdery substance resembling cocaine and another clear plastic bag containing marijuana). Close the trunk (2 points). Take the suspect to jail, book him on drugs, and deposit him there (3 points). On the way out, Jack enters the jail and tells you that Dooley wants to see you in his office.

Dooley's Office

Dooley has a memo to read to you. As he stands to read it, his eyes begin to sting and

tear profusely. The 'Gremlin' sprayed the memo with mace. Dooley races for the bathroom. On his way out, he tells you to read the memo yourself. Go behind the desk and do so. It says:

"Interdepartmental Memo

From: Lt. James Morgan, Narcotics

Re: Officer Bonds

Officer Bonds' request for a temporary transfer to the Narcotics Department has been approved. Bonds is to report to my office ASAP in suitable street clothes" (2 points). Go to your locker, take the necessary shower and change into street clothes (T-shirt and jeans). Take your gun and ammunition (you don't need your Corvette keys since you will be driving an unmarked car). Put the patrol car keys on the keyboard on the way out.

Morgan's Office

Morgan welcomes you to the Narcotics Division and explains the necessity of your new image. He's decided to put you on the Hoffman case due to your involvement in the arrest. Your partner will be Laura Watts. Join her now in her office (1 point).

Narcotics Office

Laura welcomes you. She shows you around and tells you: "Our radio call number is 83-Nora-10." She shows you your desk. She attended Hoffman's arraignment earlier that morning. Hoffman's bail was set at only \$500,000. She tells you that you've got to show cause to justify a No Bail Warrant. You must go now and discover some information that will convince Judge Palmer to hold Hoffman without bail. When Laura leaves for her meeting: Take the clipboard (from the left wall). Turn the pages (with the arrow keys) until you come to the FBI Most-Wanted List. Note that Jason Taselli is known to use the last names Harris and HOFFMAN! Take the poster. Return the clipboard (2 points). Laura reenters and tells you that Hoffman's attorney is on his way over to bail him out. You are told to take whatever you have on Hoffman and get over to the courthouse to try to get a No Bail Warrant out of Judge Palmer. Take the keys (to the undercover car) from the left wall (3 points). Approach the file cabinet and open it. Read the Hoffman file (Note the alias Leroy Pierson - remember the second driver's license in Hoffman's glove compartment). Take the Hoffman file (2 points). (You close the file cabinet). Head for the courthouse. Remember to do a safety inspection of the unmarked car in the parking lot.

Courthouse

You arrive at the courthouse (1 point). Enter the outer reception room and approach the window on the right.

Outer Reception Room

The clerk will ask to help you. You ask: Where is the judge? I need a No Bail Warrant. He says he can only interrupt the judge for an emergency. You say: It is an emer-

gency (3 points). He leaves and comes back saying: "The bailiff says Judge Palmer will see you." Open the door and enter the courtroom.

Courtroom

You are invited to approach the bench. You are asked who the warrant is for. Marvin Hoffman. You are asked what information you have to substantiate the validity of the warrant. Hoffman file. When asked for other information, respond: FBI Most-Wanted List. You give the evidence to the bailiff who delivers it to the judge. He then asks you what makes you think the two men are the same person? You respond: Tatoo. After trying to stifle her laughter, the judge grants your request and issues a No Bail Warrant in the name of Jason Taselli, alias Marvin Hoffman. You are told that Taselli's attorney is at this moment at the jail attempting his release (7 points). Head for the jail and give the No Bail Warrant to the jailer (2 points). Don't forget to lock up your gun before entering the jail and retrieve it on the way out. Next, go to the station.

Parking Lot of Police Station

When you arrive, Laura is there and gets in the car. She tells you that one of her informants just told her that a drug deal is going down soon in Lytton City Park. Lt. Morgan wants you to stake it out and see what can be done. Head for the park.

City Park

You arrive at the park (1 point). Exit your car and walk into the park. As you approach the picnic table: Draw gun. Load gun. Now go and hide behind one of the bushes. Radio Laura that you are concealed. (She will remain silent until she hears from you again). Wait until eventually a man will quietly enter the picnic area and approach the table. He keeps turning his head as if he is looking to make sure no one is around. Soon thereafter another figure (his drug contact) carefully approaches the table. The two men discuss and enter into a drug deal. They begin to argue as the pusher is dissatisfied with the contents of the envelope given to him. Radio Laura (she's moving in). Stop! Police officer (5 points). (The pusher beats it out of there while the young man gives himself up). Come out from behind the bush and approach the remaining suspect with your gun pointed at him. Handcuff suspect (1 point). Read rights (1 point). Search suspect (it reveals his school ID card and the small bag of white powdery substance he got from the pusher) (1 point). Examine the ID card (it's Victor Simms, a student at Jefferson High School). Examine the bag (it appears to be cocaine). Question Simms (you learn that he's the one who sold drugs to Cobb's daughter Kathy). Question Simms (he used to buy from Jose Martinez, but then Martinez introduced him to Colby - you've learned the name of the pusher) (2 points). Follow me. When you get to the patrol car: Question Colby

(twice - you discover that he buys his drugs from Leroy Pierson who's telephone number is 555-6537) (3 points). Put these two criminals in the back of your car and cart them off to jail. Book them for drug dealing (2 points). Head back to the station.

Parking Lot of Police Station

Laura gets out of the car and tells you she'll write up the arrest. She suggests that you go to the Blue Room and tell Jack that you nailed the rat who was dealing dope at Jefferson High.

Blue Room

Sit down next to Jack. Talk to Jack. (Trying to cheer him up you tell him about Simms' arrest and how he was responsible for selling dope at the high school. Jack appreciates your nailing him but feels it might be too late. His daughter, Kathy, is in the Intensive Care Ward at the hospital. She's in a coma from a drug OD!. A cab driver enters and Jack leaves with him. Keith enters and says he has some bad news for you. Lt. Morgan sent him here to advise you that Taselli has escaped from jail. Taselli jumped a guard and escaped over a fence surrounding the basketball yard. There is a city-wide dragnet out on him. Morgan wants to see you back in his office ASAP. Return to the station (1 point).

Morgan's Office

Stand in front of the desk. Morgan commends you on your hard work trying to keep Hoffman in jail. After receiving the Hoffman file, Morgan thinks that you should take a close look at the black book that was impounded along with his Cadillac. Get it from Russ in the evidence lockup. Check it out and bring it to Morgan (1 point).

Hallway

Walk up to the evidence window (right rear of hallway). When Russ asks you if he can help, say: Give me the black book. Return book. Give me the weapon. Note the serial number is SW9764912. Read the tag. The evidence label bears a box marked "Fingerprints" with the initials of Det. Frank Williams of the Crime Lab. Return weapon.

Computer Room

Approach the table and: Turn on computer. The search string to enter is the serial number of the weapon. It's a stolen weapon. Contact Det. Taber at CPD, 1-312-555-3382 (2 points).

Narcotics Office

Walk behind the desk (on the right) and: Dial the telephone. 1-312-555-3382 (if it's busy, try again). Taber asks "How may I help you?" You answer: Information about Taselli. He tells you that Taselli is linked to a big time card shark and drug runner

Jessie Bains. Both have dropped from sight in our area. He sends you a mug shot of Bains. He hangs up (5 points). Go back to Morgan's office.

Morgan's Office

He tells you that your friend Sweet Cheeks, who's in jail, may be able to help us out. It seems there's a drug problem emanating from the Hotel Delphoria. In lieu of her current state of affairs, Sweet Cheeks would no doubt be willing to help you establish your cover at the hotel. Head for the jail and see if she'll help with the hotel operation. When you come back, Morgan will hold a briefing on the operation.

Inside Jail

Approach Sweet Cheeks in cell #1. She tells you how she got picked up by Operation Trick Trap. She'll do anything to get out. After she kisses you: Help with hotel operation (5 points). After she kisses you again, you explain the arrangements of Sweet Cheeks' immediate release to her. You tell her that as soon as she's released, she is to go to the station for a meeting with Lt. Morgan.

On the Streets of the City

You ride around town a bit and you will eventually be summoned on the radio to head for Cotton Cove. Officers need ID on 187 victim.

Cotton Cove

You arrive at Cotton Cove and see two officers standing next to a body (2 points). Examine the body (it's covered with a blanket). Lift the blanket (the body resembles Jason Taselli - but you're not sure - you want to see if he has a tattoo in the right place above his left nipple). Open the shirt (sure enough your suspicion is confirmed) (2 points). Cover the body. Return to your car and radio dispatch with positive ID on body. You're advised that the coroner is en route (3 points). Return to Morgan's office at the station.

Morgan's Office

Standing there are Laura and Sweet Cheeks. Morgan tells you that he has devised a plan to infiltrate the gambling scene at the Hotel Delphoria. You, Sonny Bonds, are to check in to the hotel under the name of Jimmy Lee Banksten and then meet Sweet Cheeks in the hotel cocktail lounge. Signal Sweet Cheeks that you're ready to begin the operation by ordering a drink. She'll pretend to recognize you as 'Whitey', an old friend recently released from prison. She'll introduce you to bartender Woody Roberts, whom we believe is the contact man for the backroom hustle. You'll be carrying a large sum of money (marked bills) and will pretend to be eager for action. Laura has developed a disguise for you (a white suit and bleached hair). You'll walk with a cane whose handle is a detachable .22-caliber magnum Derringer. When the need arises, you will carry a voice transmitter disguised as a plain-looking ballpoint pen. Laura gives you a bottle of bleach creme activator and tells you to take it in the

shower and bleach your hair. Sweet Cheeks can't wait to spend the night with you at the hotel. She leaves for the hotel. Laura follows. Morgan asks to see you again (for more instructions) after you bleach your hair and change clothes. In comes Dooley announcing that Cobb called and said that his daughter Kathy died without ever regaining consciousness. Jack is now on extended family leave. You vow revenge for Kathy's senseless death by tracking down the dope world animals responsible (2 points). Before your shower, you want to offer condolences to Jack Cobb.

Narcotics Office

Dial the telephone. 411. Cobb. (The operator gives you the number). Dial the telephone. 555-2622. You offer your condolences to the Cobb family (3 points). Dial the telephone. 411. Williams. (The operator gives you the number). Dial the telephone. 555-4522. Detective Williams at the Crime Lab answers: "Who's speaking please?". Sonny Bonds. He asks what he can do for you. Hoffman. (He tells you that the prints on the gun matched that Hoffman/Taselli fellow) (5 points). Now go to the shower and bleach your hair.

Locker Room

Open locker (notice that your white suit (disguise) is now hanging there). Take towel. Close locker. Walk to shower and: Turn on water. Bleach hair. Wet hair. Rinse hair (you're now blonde) (3 points). Turn off water. Return to locker and: Open locker. Take clothes (your white suit). Close locker. Head for Morgan's office.

Morgan's Office

Morgan tells you that you should contact him after you infiltrate the illegal gambling activities at the hotel. He will send over a team of detectives to serve as your backups. (You need to know his phone number to do this). He gives you \$1000 in marked \$100 bills. Hamilton calls on the phone and tells Morgan that Hoffman/Taselli was showered execution-style before he decided to take his little swim (1 point). Go behind the desk and: Examine the telephone (the number is 555-6674) (2 points). Leave the radio extender at the station and head for the hotel.

Hotel Delphoria

You arrive at the hotel entrance (1 point).

Lobby

Approach the desk and: Ring bell. Check in (there is a vacancy in Room 204. The desk clerk asks for \$100). Pay clerk. You register as Jimmy Lee Banksten. He gives you your keys (3 points).

Cocktail Lounge

Approach the bar and order a drink. Woody asks: "What'll it be?". Beer. Sweet Cheeks

says: "Whitey, is that YOU?" She continues to play her role as undercover agent. You and Sweet Cheeks sit down at a table. Woody brings your drinks. Pay Woody. He goes back to the bar to get your change. In the meantime, two dudes enter the bar and walk through the door on the left. Woody brings back your change. Sweet Cheeks introduces you to the bartender. She then excuses herself to powder her nose. The bartender strikes up a conversation. You tell Woody that you just finished doing a little time for embezzlement and that he should keep that information under his hat. Sweet Cheeks returns. Woody is still tight-lipped about the backroom gambling - you try to get Woody to open up. Stand up and walk to the bar. Give money to Woody (you slip him a twenty - he has what you are looking for in the way of a good time). You tell him: "Anything, but women, gambling, and money are at the top of the list". Woody tells you about a little card game in the backroom available by invitation only. It'll cost you \$200 (3 points). You will take him up on his offer but first take Sweet Cheeks up to your room. Enter the elevator (at the rear of the lobby). Push two. You arrive on the 2nd floor. Head over to room 204 (in the hallway to the right). Unlock the door and go in (1 point).

Room 204

Sweet Cheeks asks: "Did you get anywhere with the bartender, Precious?" Yes. She asks: "Do you have enough money to carry you through a gambling session, Big Boy?" Yes. Dial the telephone (call Morgan). 555-6674. Morgan answers: "Who's speaking, please?" Sonny Bonds. He keeps the cover: "Hello, Mr. Banksten (you can never tell when the phone is being tapped). Why don't you send Sweet Cheeks Marie back to the station by cab. Try to get behind the scenes at the hotel. Your backup personnel will be arriving later this evening. Good luck" (3 points). Dial the telephone. 411. Lytton Cab. (The operator gives you the number). Dial the telephone. 555-9222. The person on duty at the cab company asks: "Where's the pickup?" Hotel Delphoria. You tell Sweet Cheeks to catch a cab and go to the police station. She leaves (3 points). Go to the elevator, push one, and return to the cocktail lounge.

Cocktail Lounge

Approach the bar and: Give money to Woody. Woody tells you to follow him (1 point). He escorts you to a door at the rear of the storage room. He frisks you and then sends you into the poker room. Sit down (in the empty chair at the rear left table). You are introduced to the other players at the table, Otto and Gene. In walks a man who sits down at your table. You are introduced to Frank. Play poker. (Between games, you must type the word: Deal). Eventually, you will win enough for Frank to congratulate you. You are told that if you want to come back and play more, then give Woody the password: "Frank sent you!" and he'll let you in for free. Frank also

suggests that the two of you might talk a little business afterward (3 points). Go back to your hotel room.

Room 204

Wait for your backup officers to arrive. Eventually, you will hear a knock on the door followed by the turn of the doorknob. Three men enter. Approach the man on the left and say: "Give me the transmitter pen". Detective Angland hands it to you along with a new supply of marked \$100 bills. Angland indicates he'll monitor your voice transmitter at all times. He tells you to take a look at the mug shots of Jessie Bains that came across on a fax from Chicago (5 points).

Cocktail Lounge

Approach Woody and tell him: Frank sent me. He leads you back to the poker room for the big game. After again frisking you, he escorts you this time to the private poker room at the rear of the poker room.

Private Poker Room

Sit down in the vacant chair. Frank welcomes you back. As you sit there watching him shuffle the cards, you realize that he exactly matches the description of Jessie Bains - THE DEATH ANGEL! Play poker. When you win enough, Frank will again congratulate you (3 points). Frank then asks: "Whitey, I understand you may be looking for work?" Yes. He then asks: "How would you like to join me in my suite for a drink, Whitey? I've a business proposition to discuss with you." Yes. Follow Frank up the stairs to his suite (Room 404). When he enters his room (and before you do), radio your backups (now with the transmitter pen) (5 points).

Frank's Suite

Frank offers you a proposition. You accept. The phone rings in the next room. Frank tells you to fix yourself a drink while he goes to answer the phone. Frank returns. Frank draws his gun and aims it at you. Just then a knock on the door diverts Bains' attention. You dive to the floor and struggle to remove the Derringer from your cane. Your backups have arrived. You shoot several times and send Bains to the floor.

You wind up back in the courtroom to hear the verdict on the various convictions (4 points). You appear on the front steps of the courthouse. The mayor presents you with the keys to the city and gives you a ticker tape parade down Main Street.

Shadows of Mordor

I shall assume that you play the part of Frodo.

e	sw
se	s
e	Sam "give the rope to me"
Sam "hit Smeagol" (immediately type the next command before Smeagol runs away)	tie the rope to the stump climb down the rope take the rope
Sam "tie Smeagol with the rope" (Smeagol begs for you to take it off)	e sw
Smeagol "no" (Smeagol again begs for you to take it off promising to show you the way into Mordor. This is important since if you don't get Smeagol to accompany you on your journey, you will reach a point in the game where you cannot continue on your own)	drop all but the ring Sam "drop all" e se (you see 4 logs) drag the log Sam "drag the log"
Smeagol "promise" (Smeagol sullenly promises to be good)	s nw sw
untie Smeagol (he will now follow you. Frodo now carries the rope)	drop the log Sam "drop the log"
n	e
e	se (you see 2 logs)
break the tree with the sword	drag the log
take the branch	Sam "drag the log"
lever the stump over the cliff with the branch (you expose a hole in the ground)	s nw sw
examine the phial (it's for providing light)	drop the log
d (it's dark and you cannot see)	Sam "drop the log"
raise the phial	take the rope
s	make a raft
d	take the branch, shirt, and small sword

Sam "take the bread, beautiful sword, and matchbox"
get on the raft (Sam follows suit)
Smeagol "get on the raft"
pole the raft with the branch (you wind up on the southern edge of the swamp)
get off the raft
Smeagol "get off the raft"
drop all but the ring and branch
get on the raft (Sam follows back on)
Sam "get off the raft"
pole the raft with the branch
take all but the rope
pole the raft with the branch
get off the raft
take all
give the backpack, cloak, and little box to Sam
e (typically Frodo will be hungry and tired by this point. If so, "Eat the Bread")
se (wait until Smeagol suggests going east. Without Smeagol in your party, it would not be possible to go east at this point in the game)
e
se (if you encounter the black rider here or at other locations in this vicinity, just "wait" until he flies away)
s
climb the tree (this assumes there are no orcs present. If orcs are here, they won't let you climb the tree. In that case, try to get here along a different path. Also, if the orcs kill one of your

party, reload a previously saved game and try again)
Sam "climb the tree"
wait (until an orc (say the wimpy one) enters)
Sam "jump on the wimpy orc" (he knocks it unconscious)
wait (until the other orc (the skinny one) enters)
jump on the skinny orc (you knock it unconscious)
Sam "attack the wimpy orc" (he kills it)
attack the skinny orc (you kill it)
examine the wimpy orc (it has orcish clothes and a hammer)
Sam "take the orcish clothes"
Sam "wear the orcish clothes"
examine the skinny orc (it has a hair shirt, a sickle, and a fishing-line)
take the hair shirt and the fishing-line
wear the hair shirt (you and Sam are now disguised as orcs)
s
nw
s
s
take the parchment
n
se
s (you see a short stout orc and a tall thin one. Each is carrying a sword. The short stout one asks to see your pass. Ignore him. Since you and Sam are disguised as orcs, you won't be

stopped from going on)
s
drop the hair shirt
Sam "drop the orcish clothes"
sw
s
wait (until Smeagol disappears and then
returns with a plump young rabbit)
take the rabbit
go fishing (repeat until you catch one on
your fishing-line)
take the fish
go fishing (repeat until you catch another
one)
take the fish (you will now have a small
slippery fish and a large ugly one.
Somewhere along now, Faramir will
enter and will ask who you are.
Smeagol disappears into the bushes)
Faramir "hobbits" (Faramir tells you to
stay here and await his return. He's
about to set a trap for Sauron's troops.
He goes east)
wait (until the enraged Oliphaunt enters)
n
wait
s (the Oliphaunt should be gone)
wait (until Faramir returns. He informs
you that the battle went well and it is
safe to go on. He gives his rations to
Sam)
Sam "drop the backpack"
open the backpack (in it are a frying pan
and some salt)

take the frying pan
break the branch (twice. It is now some
twigs)
drop the twigs
Sam "open the matchbox" (in it are 6
matches)
Sam "light the match"
Sam "light the twigs with the match" (you
now have a bona fide fire suitable for
cooking a fish)
put the large fish in the pan
put the pan on the fire (the fish is cooked.
That sure was quick)
take the large fish and the pan
eat the large fish (you and Sam each eat
some of the large fried fish)
put the rabbit in the pan
put the pan on the fire (the rabbit is
cooked)
take the rabbit
eat the rabbit (you and Sam each eat some
of the rabbit)
put the pan in the backpack
Sam "take the backpack"
put out the fire (unless it already went out
by itself)
e
se
n
n
go through the waterfall
se (you meet up once again with Smeagol
who is very hungry)
give the slippery fish to Smeagol (he eats
some of it)

nw (Sam and Smeagol follow)
go through the waterfall
s
s
e
se
e
n (suddenly, Frodo's eyes go glassy. He
calls out "Yes Master, I'm coming".
Frodo goes east to the crumbled ruins
of a city beneath the evil shadow of
the tower of Minas Morgul. You must
move quickly else Frodo will go
northeast to the tower and die)

n

w

u

u

e (you see a wolf)

Sam "drop the bread" (the wolf eats some
of it)

ne

e

raise the phial

look (you are in a rough dark tunnel)

wait (until the spider (Shelob) appears and
rears up to attack Frodo. You must
now use some magic)

Galadriel (the spider screams in agony and
retreats back into the darkness)

se

e

e

n

se

cut the web with the small sword (Frodo
drops the small sword and yells,
"We're free. Sam, we're free!").

Frodo runs outside)

take the small sword (Sam does so)

e (the spider rears up and tries to attack
Sam)

kill the spider with the beautiful sword
(repeat until Sam kills the spider)

cut the cocoon with the small sword (in it
is Frodo)

examine Frodo

wear the ring

wait (until the platoon of orcs appear and
pick up Frodo's body from the

cocoon. The platoon of orcs go north.

Follow them)

n (the platoon of orcs go west)

w (the orcs pass through the sturdy iron
door with Frodo's body before Sam
can reach it. Congratulations! You
have won the game)

Sherlock Holmes: The Riddle of the Crown Jewels

knock at the door

n

take the slipper

take the pipe (score = 1/100)

take the newspaper (score = 2/100)

read the newspaper to Holmes (Holmes comes out of his stupor and calls down to Mrs. Hudson to bring up a tray of food) (score = 7/100)

wait (the visitor accompanies Mrs. Hudson up to Holmes's study. He gives Holmes a wrinkled paper on which is written some verse)

read the verse (it contains 4 verses which are in the form of riddles. The first refers to Westminster Abbey, a place where English royalty is buried. The second refers to Queen Elizabeth who was the last of the Tudor monarchs and called the "Virgin Queen". The third refers to Sir Isaac Newton whose observation of the falling apple led him to discover gravity. The fourth refers to the son of someone who died in the holy city of Jerusalem. When you explore the Jerusalem Chamber in Westminster Abbey, the identity of this person will be revealed. This set of verses was left by the thief for the purpose of laying down a trail of clues for Holmes to follow. The thief is challenging Holmes to a duel of wits. Since Holmes is not armed for such a match, you, Watson, will have to take over)

wait (the visitor informs Holmes that the theft can only be hidden from the

public until Monday morning 9:00 a.m.

It is now shortly after 5:00 a.m. on Saturday. You have your work cut out for you. The visitor leaves. Holmes unlocks the bedroom door, gets his cape and hat, and tells you that he will wait for you outside)

w

take the lamp (score = 10/100)

take the magnifying glass (score = 11/100)

take the ampoule

e

s

d

n

take the matchbook (score = 12/100)

s

open the front door

e

light the lamp

n

e

e

s

ne

read the sign (the museum opens at 8:00 a.m.)

wait 1 hour (repeat until the time is 8:00 a.m. and a guard opens the door)

n

e

look at the old book (on the table) (despite the fact that there is a sign on the librarian's desk that says "Quiet, please", he continues to jabber away distracting you from what you want to do)

tell the librarian to be quiet (he gets the message and leaves)

look at the old book (it's called "Secret Writing and Invisible Inks")

open the old book

read the old book (it talks about how to use heat to expose invisible writing created by using invisible ink on a surface)

w

s

sw

s (note the statue of Lord Nelson sitting on top of a 167 ft. column)

look at the relief (it talks about how during the battle of Copenhagen, Lord Nelson clapped his telescope to his blind eye....This is a hint, which you will make use of in due time, as to how to look at the statue)

s

s

sw

e (in the nave of Westminster Abbey)

s

se (in the north cloister - brass rubbings made from various inscriptions around the abbey appear on the walls. You are about to make some of your own)

take the packet (score = 13/100)

open the packet then look at it (in it are a number of pieces of colored paper)

take the crayon (score = 14/100)

nw

open the door

s

w (in the Jerusalem chamber)

read the sign (you learn that the fourth verse refers to Henry V, son of Henry IV who died in Jerusalem)

e

n

n

look at the tomb (it's a tomb of Sir Isaac Newton)

take the brown paper (from the packet)

put the brown paper on the tomb

rub the brown paper with the crayon (the inscription comes off on it)

take the brown paper

ne

e

look (there is a bank of candles here lit by devoted worshippers)

hold the brown paper over the candles

turn over the brown paper (on it are two riddles - the first refers to something under the London Bridge. The second refers to a number that you're BANK-ing on. The riddle also mentions subtracting the CONQUEST from the FIRE alluding to the subtraction of a number associated with a statue of William the Conqueror that you will come across from a number on the plaque of a monument of the Great Fire of London that you will also find)
(score = 19/100)

s

e

look at the tomb (it is that of Queen Elizabeth)

take the blue paper

put the blue paper on the tomb

rub the blue paper with the crayon

take the blue paper

s

w

look at the tombs (one is that of Henry V)

take the yellow paper

put the yellow paper on the Henry tomb

rub the yellow paper with the crayon
take the yellow paper

e

nw

n

hold the blue paper over the candles

turn over the blue paper (on it are two
riddles - the first refers to the clock
(Big Ben) striking nine - obviously this
reminds you of the time by which you
must solve the mystery. The second
refers to a chopper (perhaps an
executioner) who is about to chop off
someone's head. In due time, you shall
discover such a scenario)

hold the yellow paper over the candles

turn over the yellow paper (on it are two
riddles - the first refers to the son of
Mars, an English naval hero. The
phrase "now above the world so high"
refers to a statue of him sitting high
above the ground. Putting these
together produces Lord Nelson whose
statue sits on top of a tall column in
Trafalgar Square. The second is the
familiar pussycat, pussycat, where have
you been rhyme which here is a clue
telling you to go to the Tower of
London)

drop the packet and the crayon

w

sw

w

ne

w

examine the telescope (it's not worth the
pound the vendor is asking for it)

bargain with the vendor (twice. He offers
it to you for 19 shillings)

buy the telescope (he sells it to you and

gives you a shilling as change) (score
= 20/100)

e

n

n

n

e

e

s

w (in Sherman's pet shop)

ask Sherman about the pigeon (you learn
that upon command the trained bird
will go and get any item you tell it to
provided that it is red in color)

ask Sherman for the pigeon (score = 21/
100)

e

n

w

w

s

look at the statue through the telescope
(you see a red ruby in Nelson's blind
eye. Since the statue is too high to
reach or climb, maybe you can use the
"red-loving" pigeon to get the ruby for
you)

show the ruby to the pigeon

tell the pigeon to get the ruby

drop the pigeon (it flies up into the air, gets
the ruby, but instead of coming back to
you, it just circles high over your head)

drop the telescope

n

e

e

s

w

ask Sherman about the pigeon (being a
homing pigeon, it returned to Sher-

man's shop with the ruby. Sherman gives you the ruby.) (score = 26/100)

e
n
w
w
n
w
drop the newspaper
take the tobacco (from the slipper) (score = 27/100)
put the tobacco in the pipe
open the matchbook
take the match then strike it
light the pipe with the match
drop the match and the matchbook and the lamp and the slipper
n (score = 28/100)
w
look at the wax statues
look at the Guy statue (it's holding a torch awaiting a signal to be lit and set off the trail of gunpowder that will blow up Parliament)
light the clue paper (with the tobacco)
take the torch then light it with the clue paper (score = 32/100)
look at the Charles statue (it shows Charles I with his head on a chopping block about to have it chopped off by the axe of an executioner. Remember the chopper riddle from the rubbing on the blue paper)
take the wax head
melt the wax head with the torch
take the gem (it's an emerald) (score = 37/100)
e
look at the statues (one of them is William the Conqueror)

look at the William statue (it refers to the Battle of Hastings in 1066. This is one of the two numbers needed to solve the "numbers" riddle from the rubbing on the brown paper)

s
take the lamp
e
s
e
s (you see a girl who has collapsed on the ground)
take the hat (you see a stethoscope)
take the stethoscope (score = 38/100)
wear the stethoscope
listen to the girl with the stethoscope (her heartbeat is very slow (or incredibly fast). She needs some medicine to speed it up (or slow it down))
open the black bag (inside is a brown bottle and a blue bottle)
look at the blue bottle (it's labelled "Digitalis leaf. For tachycardia and other accelerated arrhythmias.")
open the blue bottle (it contains an orange pill and some cotton balls. You will need the cotton balls later on)
look at the brown bottle (it's labelled "Belladonna. For bradycardia and other decelerated arrhythmias.")
open the brown bottle (it contains a yellow pill)
take the yellow (or orange) pill then give it to the girl (that does the trick. She (Eliza) puts a carnation in your lapel and is then escorted away by a distinguished-looking gentleman) (score = 43/100)
remove the stethoscope
s

sw
s
e
d
look inside the boat
take the oar (score = 44/100)
u
w
s
se
u (in the clock tower)
take the cotton balls (from the blue bottle)
put the cotton balls in the ears
wait (repeat until Big Ben sounds on the next hour. The clapper will swing toward you. You can now reach the sapphire. You will miss it on the first BONG but will get it on the next. Note that it must not be 1:00 p.m. or else the clapper will only ring once. If you didn't have the cotton balls in your ears, when the bell sounded, you and Holmes would clap your hands to your ears in an attempt to protect them and, in doing so, drop all your inventory. Since your hands would be covering your ears, you couldn't take the sapphire)
take the sapphire (three times) (score = 49/100)
remove the cotton balls
drop the cotton balls and the black bag
d
nw
n
n
ne
e
s (at the embankment. There is an old rowboat here with one empty oarlock)

enter the boat
put the oar in the oarlock
take the anchor
launch the boat
row east (twice)
drop the anchor
look under the bridge (you see a clump of moss lodged among the supports.
Under normal circumstances, you can't quite reach it. To get it, you must wait for high tide. The tide tables that apply on the weekend are in the newspaper that came with the game)
wait (repeat until the time corresponds to high tide, e.g., 8:46 p.m. on Saturday. See the Weekend Almanac in The Thames newspaper that came with the game for other times.)
take the moss (it crumbles as soon as you touch it leaving you holding a beautiful opal) (score = 54/100)
take the anchor
row west
row west
row north (you land the boat on the Embankment)
leave the boat (as you leave, a man accuses you of having taken his boat. Without waiting for a response, he jumps in the boat and takes off)
e
e
n (at the monument)
look at the plaque (on it is the number 1666. You can now solve the "numbers" riddle. Merely subtract 1066 from 1666 to yield 600)
nw
nw
show the ruby (or any of the other three

jewels) to Holmes (he identifies it as not being one of the Crown Jewels. He takes off his signet ring and tells you that, if anything should happen to him, to take the ring to his brother Mycroft at the Diogenes club) (score = 55/100)

look at the ruby through the magnifying glass (you see "Wear a carnation" scratched into its surface)

look at the opal through the magnifying glass (you see "Password: Swordfish" scratched into the surface)

look at the sapphire through the magnifying glass (you see "2:00 a.m." scratched into the surface)

look at the emerald through the magnifying glass (you see "20/6/87" scratched into the surface)

read the sign (the bank is closed for the weekend. Somehow, you must get inside anyway. You want to bribe the guard)

give the emerald and the ruby to the guard (that's not enough)

give the opal and sapphire to the guard (he whispers to you to go. Now all you need is his keys) (score = 58/100)

look at the urchin (it's Wiggins, head of Holmes's unofficial army of street urchins)

ask Wiggins to steal the keys (he wants a shilling to do it. Good thing you bargained for the telescope and didn't pay the full price)

give the shilling to Wiggins

ask Wiggins to steal the keys (he does so) (score = 59/100)

n

examine the vault

wear the stethoscope

listen to the door (at the moment it is silent. As you turn the dial left or right, you will hear "clunk", "whirr", or "click" respectively indicating that you are going the wrong way, you are going the right way, or you should reverse directions. Also remember the information scratched on the emerald - a two-digit number followed by a one-digit number followed by a two-digit number)

turn the dial right (twice)

turn the dial left

turn the dial right

turn the dial right (the vault door swings open) (score = 62/100)

remove the stethoscope then drop it

w

look at the boxes (now is the time to use the number you deduced from the "numbers" riddle)

open box 600

take the topaz (score = 67/100)

look at the topaz through the magnifying glass (you see "Bar of Gold" scratched on its surface)

e

s (Holmes is kidnapped. Remember what he told you to do if something happened to him)

w

w

s

s

sw

w (in the Diogenes club)

ask the butler for Mycroft (he wants a token of identification)

give the ring to the butler (Mycroft appears. He tells you to go to the

Tower of London and give the password 'XXXX' (this changes from game to game) to the guard at the Byward-Tower. He then disappears) (score = 68/100)	e
e	d
ne	put on the suit of armour
e	u
s	w
e	s
e	s
e	take the paddle (score = 78/100)
e	pull on the chain (the gate opens) (score = 79/100)
e	s
e	enter the boat
e	take the anchor
guard, the password is XXXX (the guard steps aside as you enter the outer ward) (score = 71/100)	launch the boat (the oars that were there before are no longer there)
n	paddle west (three times)
n	paddle north
se	drop the anchor
u	leave the boat (once again the owner of the boat is here. As you leave, he jumps in the boat. However, since there are no oars and you have the paddle, he has no means of steering the boat. He goes drifting down the Thames screaming and shaking his fist at you)
look at the weapon (it's a medieval mace)	remove the suit of armour (you leave it on the ground)
take the mace (score = 72/100)	e
d	e
nw	d
ne	put the ampoule in the hat
look at the keg (it's filled with malmsey)	wear the hat
knock out the bung with the mace (the malmsey streams out of the butt)	w
look inside the keg (you see a garnet)	wait (repeat until the time is 2:00 a.m. on Monday - remember the message scratched on the sapphire)
take the garnet (your broad shoulders and short arms prevent you from reaching it)	ask the proprietor for Akbar (he asks you for a password)
ask Wiggins to get the garnet (he climbs in the keg and gets it for you) (score = 77/100)	swordfish (remember the message
look at the garnet through the magnifying glass (you see "Give me to Akbar" scratched on its surface)	
sw	

scratched on the opal. The proprietor disappears into a back room and returns moments later with an Indian man)
give the garnet to Akbar (he takes it along with all of your inventory. (Good thing you were wearing your hat). He blindfolds you and takes you to Moriarty's lair. The Crown Jewels are spread out on Moriarty's desk just inches away from Holmes who is seated tied to a chair) (score = 84/100)
ask Moriarty about the Crown Jewels
take the hat
take the ampoule
take a deep breath (Holmes does too)
open the ampoule (the room fills with etherium. Everyone has passed out except Holmes and yourself)
untie Holmes (you keep the rope)
tie Akbar
tie Moriarty (you no longer hold your breath. The etherium knocks you out. When you awaken, it is 8:30 a.m. You don't have much time)
take the key and the Crown Jewels and the whistle (score = 94/100)
give the Crown Jewels to Holmes (he tells you that you must get them to Buckingham Palace before 9:00 a.m. No great surprise)
unlock the door with the key
open the door
n (you are on the London Bridge and somewhat disoriented. If you start to walk to another location, you will notice that the clock now advances 5 minutes per move. There is obviously not enough time to get to the Palace by foot. Clearly you must call a cab)
blow the whistle (twice - a hansom cab

pulls up) (score = 99/100)
enter the cab (he asks where you want to go)
Buckingham Palace
show the Crown Jewels to the guard (he examines them and disappears into the palace. He reappears moments later with the Prime Minister who ushers you and Holmes into the presence of the Queen. After being extended her gratitude, you are ushered back out into Queens Gardens where the two of you join the crowd to cheer the appearance of the Queen on the balcony wearing the full regalia. You earn the rank of Consulting Detective) (score = 100/100)

Space Quest II: Vohaul's Revenge

Outside Orbital Station 4

Look at the watch. (H = horoscope, T = time and temperature, C = image of your boss).

Type: C (your boss orders you into the shuttle to clean up a mess) (1 point). Climb up the wall, onto the ceiling and into the red port. (You are encapsulated by a plastic bubble and whisked away to the airlock chamber).

Airlock Chamber

After decontamination, approach the suit on the left of the rear wall. Change suits (2 points). Search your suit. (It contains an order form and a dialect translator). Approach the lockers on the right wall. Open the locker. Take all (the cubix rube and the athletic supporter) (2 points). Close the locker. Exit through the door on the left.

Transportation Control Room

You meet your boss who chastises you some more. Move to the left of the screen and stand on the square striped pad. It is a platform that will rise and take you up to the transporter tube. Walk along the ledge and enter the tube through the hatch.

Shuttle Bay

Come down the stairs from the transporter tube and enter the shuttle (by going up the ramp underneath it). Upon entering the shuttle, you find that you are not alone. You encounter two interstellar ruffians who proceed to thump you around finally knocking you unconscious. When you awake from your dream, you find yourself being held captive under physical restraint by the two goons you met on the shuttle. Your hands are tied behind your back. Sitting before you is Sludge Vohaul (5 points).

Sludge Vohaul

Sludge talks to you about the Star Generator and his plan for revenge. He tells you that you are about to be escorted to the surface of Labion where you will perform many painful hours of manual labor in his mines. You touch down on a landing platform and are ushered away to the mine site. On the way, your hovercraft runs out of fuel and you and your ushers crash to the ground. Fortunately, one of them breaks your fall. You land in an exotic forest along with the wreckage of the hovercraft and bodies of your former captors.

Exotic Forest

Search the body (of the captor on the left). (You find a small, thin, magnetic keycard). Take the keycard (3 points). Search the hovercraft. (You notice a button with a

flashing light next to it emitting a high pitched beep - it's a homing device). Push the button (the light goes dark and the beep stops) (1 point). Move one screen to the right being careful not to walk on the concealed pit (a faint rectangular outline in the middle right of the grass).

Giant Mushrooms

Keep away from the mushrooms. They are traps. Go back to where your hovercraft crash-landed and go north one screen (from behind the trees).

Strange-Looking Forest

Immediately go between the rock and the large tree trunk and hide behind the latter. First you will hear a TWANG followed by a high pitched shriek coming from somewhere to the east. You will want to investigate this noise. However, for the time being, remain hidden until a hovercraft with one of Vohaul's thugs appears. It will fail to spot you and be off to search elsewhere (5 points). Come out from behind the tree trunk and go east.

Forest (Heavy Growth)

You see a pink alien creature hanging on a rope from a tree. Go over to it and: Untie the Creature (5 points). Go back west and then west one more screen staying on the upper portion (the plateau) of the cliff.

Clearing in Forest

There is a mailbox here. Mail the order form (for the free Labion Terror Beast Mating Whistle) (2 points). The mailbox hums and buzzes for awhile. Then, an object drops into the tray. Take the whistle (2 points). Now, walk off the cliff (thanks to some fancy footwork, you survive the fall) and go over to one of the clusters of balls on the ground. Examine the ground (you see some growths which look like spores or pods). Take the spore (Don't break it as it is a poisonous spore that will cause paralysis if opened) (4 points).

Root Maze

Walk through the maze being careful not to touch any of the roots (else the root monster will devour you) until you reach the berry bushes (at the rear of the screen). Frequently save the game along the way. Pick the berries (4 points). Now go back out through the maze the way you came in (4 points). Go back to the top of the cliff (plateau) in the Strange-Looking Forest and go east (at the rear of the screen).

Edge of Eerie Swamp

Before entering the swamp: Rub berries on self (You now smell like a walking ammonia inhalant) (3 points).

Swamp

About one-third of the way across the swamp, you will feel something slimy clamp down on your leg and almost as suddenly spit you out. (Good thing you rubbed the berries on your body). As you continue across the swamp, head toward the rear of the screen. You will encounter a deep part of the swamp and start to swim. Take a breath (you dive below) (2 points).

Underwater Cavern

Go straight to the bottom and then west (under the rock) to the next portion of the cavern.

Underwater Cavern (Grotto)

At the left of the screen, you will see rays of light. Go up from there and you will be in a small grotto below the swamp (2 points). Take the glowing gem (from the top of the boulder) (3 points). Since you can now breathe freely, get back in the water and: Take a breath (2 points). Head on out of the cavern, up to the surface of the swamp, go east one screen, and finally out of the swamp at its east end. Go east one screen.

Forest (Fissure)

There is a dead tree in front of the fissure. Climb the tree (3 points). (The tree breaks and falls across the fissure). Inch along the broken tree trunk until you are on the other side of the fissure. Go one screen to the right.

Thinly-Forested Area

As you walk toward the middle of the screen, you will be snared (by a rope from a tree). After you hang suspended there awhile, you will pass out. You have some strange dreams, e.g., you imagine you are Leisure Suit Larry in Land of the Lounge Lizards.

Well-Hidden Clearing (Cage)

You awake to find yourself imprisoned. A rope sits on one of the boulders. A large beast (hunter) is nearby sitting by the fire. Move to the door of the cage and: Call the hunter (twice). When he comes near the cage: Throw the spore at the hunter. (The

spore breaks and the gas emitted paralyzes the hunter) (5 points). Search the hunter (you find a key in his possession). Take the key. Unlock the door. Open the door. Exit the cage and go to the boulder just behind and to the left of it. Take the rope (2 points). Go north one screen.

Edge of Forest (Cliff)

Stay toward the bottom of the screen (to avoid a hovercraft with two of Vohauls thugs).
Go left two screens.

Forest (Fissure)

Climb log. When you get halfway across the log: Tie rope to log (2 points). Climb rope (you head down into the fissure).

Inside the Gorge

You see a ledge to your left and a mammoth beast to your right.. Go to the end of the rope (without falling off) and: Swing. Swing back and forth until the beast swipes at you about three times. Then at the end of your swing (closest to the ledge), let go of the rope (5 points).

Cave

Walk into the dark cave and: Use the glowing gem (the cave becomes aglow) (1 point). Continue to walk west (pass behind the two bumps on the ground) until you reach the left of the screen at which point the ground below your feet disappears and you tumble down through the darkness.

Bottom of Gorge

You wind up out of the cave at the bottom of the gorge. Some little pink aliens appear and (using the translator) you interpret them to say: "Follow us beanpole". First go back to the entrance of the cave and: Take the glowing gem (it's on the ground) (1 point). Now follow the aliens southeast.

South End of Gorge Bottom

The aliens welcome you to their canyon and thank you for saving their compadre from the hunters. They tell you that you can stay in the canyon as long as you like. When you are ready to leave, simply say the word (literally) and you will be shown the way out. Type: Word. The pink alien moves a boulder which reveals a hole in the ground with a ladder to go down into it. (3 points). Go down into the hole.

Cave Maze

Put gem in mouth (you now have a little light to see yourself on the ladder and your hands are free to hold on). Climb to the bottom of the ladder and move your way through the maze by climbing ladders and crawling along the tunnels until you reach the exit which leads to a waterfall (20 points).

Waterfalls and Cascades

Enter the water and swim across the screen exiting in the lower right hand corner.

Fork in Underground River

Swim up and around until you reach the fork in the river. Now swim right to the next screen.

Whirlpool

You are sucked down in the whirlpool and eventually wind up in a pool.

Pool (Carved Rock)

A waterfall spews from the mouth of an ugly face which is carved in a strange rock. Go right one screen (5 points).

Clearing

Before you leave the pool: Blow the whistle. (You hear an incredible whirring and grinding sound coming from the north. Suddenly, a Labion Terror Beast breaks through a boulder and buzzes into the room like a tornado) (5 points). There are two approaches you can take to allow you to go north through the hole in the boulder.

- 1) Swim back to the west one screen (the beast will not follow you into the water) and then swim east again returning here (the beast will be gone) (no points)
- 2) Get out of the water. Throw the puzzle (cubix rube) at the beast (as soon as he buzzes near enough to you. The puzzle attracts his interest) (10 points).

Before you go through the opening in the boulder: Take rock (from the debris on the ground) (2 points).

Clearing (Bottom of Landing)

Stay hidden behind the bush in front of you. While hidden: Sling the rock at the guard (using the athletic supporter). The rock hits the guard in the side of the head and he drops like a lead parakeet to the ground (20 points). Approach the right support of the platform. Examine the door. (On the left side is a thin slot). Put the keycard in the slot (5 points). You enter the elevator and rise up to the top of the landing platform.

Top of Landing Platform (Shuttle)

Walk around to the rear left of the shuttle and: Open the door.

Inside Shuttle

Examine the panel. (There is a POWER button, an Attitude dial, and an Ascent Thruster button). Push power button. Look at screen. Turn Dial (it's now set to VAC). Push thruster button. Pull throttle (or press down arrow key or pull back on joystick). The shuttle will take off. Eventually you will leave the planet (20 points). Keep pulling on the throttle until you hear a tone sound and a soft voice indicating that adequate altitude has been achieved. Ascent thrusters are now ineffective and you no longer have vertical control of the craft. The view outside the shuttle will change from a blue sky to a black background with stars. There is nothing for you to do now but wait until Sludge Vohaul appears on your screen. He has taken over control of your vehicle and will pilot it to his command post. All you can do is hang on. The ship will bank and head for Vohaul's asteroid. It lands on a platform inside the vehicle bay.

Platform Inside Vehicle Bay

The doors to the vehicle bay close. Walk to the right (east) along the rear walkway which is connected to the platform until you reach the next screen.

Large Room (Elevator)

Enter the elevator. Push button three.

Tube-Like Hall (Elevator - Level Three)

Exit the elevator and go three screens to the right. If you meet a floor waxer on the way, there is no way you can pass it. Retreat all the way back to the elevator, enter it, and wait for the floor waxer to pass you. Then exit the elevator, and head back to where you were.

Tube-Like Hall (Closet)

Walk to the right of the door and: Push button (the closet door opens). Enter the closet. Look closet (it's dark but you find a plunger). Take the plunger (1 point). Exit the closet and walk to a hall with an elevator (three screens back or two screens forward). Enter the elevator. Push button four.

Tube-Like Hall (Elevator - Level Four)

Exit the elevator and go three screens to the right.

Tube-Like Hall (Closet)

Walk to the right of the door and: Push button (the closet door opens). Enter the closet.

Look closet (it's dark but you find a glass cutter). Take the glass cutter (1 point).

Exit the closet and walk one screen to the left.

Tube-Like Hall (Two Doors)

Push button. Open the door (either one). Enter the lavatory, walk to the rear to the only empty stall. Open the door. Enter the stall. Close the door. Sit. (You do your thing). Take toilet paper (1 point). Open the door and leave the lavatory. Walk to a hall with an elevator (two screens back or three screens forward). Enter the elevator. Push button five.

Tube-Like Hall (Elevator - Level Five)

Exit the elevator and go two screens to the right.

Tube-Like Hall (Closet)

Walk to the right of the door and: Push button (the closet door opens). Enter the closet.

Look closet (it's dark but you find a basket, and a pair of overalls). Take the basket (1 point). Take the overalls (being quite worn, you toss them back on the floor. As you set them down something falls on the floor). Look floor. Take the lighter (1 point).

Exit the closet and walk left to the hall with an elevator (two screens back. There is also a hall with an elevator three screens to the right; however, one screen forward a spiny beast will come out of a cage and plant a French kiss on you stunning you for a while. Also, if you are not careful, some of the cages have creatures that will reach out and put an end to you). Enter the elevator. Push button one.

Large Room (Elevator)

Go back (left) along the rear walkway to the platform where the shuttle landed. Walk onto the platform and then south (going under the front walkway) to the next screen.

Tube-Like Hallway (Barriers)

Walk to the right (a barrier springs up before you). Walk to the left (another barrier stands in your way). You feel the floor shift below you. Moving toward you is a pool of acid. Type: Attach plunger to barrier (but don't press the RETURN key until the acid pool is almost touching your feet) (10 points). When the acid pool reaches the left barrier, it will then retract all the way (you release your grip on the plunger and drop back down. The barriers disappear) (10 points). Walk to the right (or left) until

you are standing under a sprinkler (still on this screen). Put toilet paper in basket (1 point). Drop basket (1 point). Light toilet paper (with lighter). The fire causes the sprinklers to turn on. The fire is extinguished. Moreover, a loud series of pops is followed by the smell of fried electronics. You've shorted out the wallbots in the adjacent rooms (10 points). The sprinklers turn off. Go right two screens.

Vohaul's Secret Chamber

Vohaul is seated before a large console high on a platform in the center of the room.

Standing ready are many of the dreaded salesman clones. Vohaul spins around and talks to you. He tells you of his plan to send the salesman clones to Xenon. He invites you to stick around and see the downfall of your civilization. Go up the stairs to the platform. As soon as you reach the top, you are struck by a beam of light emitting from a unit in the ceiling. The beam breaks you up in micro-particles which are then extracted into the air. You are molecularly reconstructed in miniature form inside a glass bell jar.

Inside Glass Jar

Cut glass (with glass cutter) (5 points). Exit the jar and go left to the vent. Enter vent (being miniature, you can wriggle through it).

Vohaul's Life Support System

There is a sign on the back wall. Read the sign. It says: "CAUTION: Press Button for Emergency Shut Off". (Just the thing you want to do). Go behind the life support apparatus and: Push button (10 points). Exit vent.

Inside Glass Jar

Vohaul flips a switch before he dies. As you will soon find out, this activates a 7-minute timer which at the end of its count will launch the clone salesmen to Xenon. You must hurry to turn it off. But first you must get yourself back to normal size. Go left one screen.

Walking on the Control Console

Walk around the keyboard to the On-Off switch. Lower switch. Type: Enlarge. Go right one screen

Inside Glass Jar

Enter the jar. (You are reconstituted back to normal size and are standing back on the platform in Vohaul's secret chamber. The clones are gone).

Vohaul's Secret Chamber

Walk up to the front of the chair (where Vohaul's body lies) and: Search body. Written

in pen on the back of his left hand are the letters SHSR (clearly some kind of code). Approach the flashing screen on the console and: Look screen. The 7-minute timer is counting down. Type: SHSR. The countdown stops and the clone infestation plan is aborted (10 points). Go up the stairs on the right of the platform.

Clear Tubular Passageway

Open the box (one the wall where you entered). You remove an oxygen mask from it (2 points). Walk along the tube to the next screen.

Clear Tubular Passageway

Wear mask (immediately upon entering). Walk along the tube. Somewhere along the way you will hear the message: "40 minutes until meltdown" (Obviously another plot executed by Vohaul before he died). Continue along the tube to the next screen where you re-enter the interior of the fortress. Walk three screens to the left.

Hallway (Escape Pods)

Upon entering, the two-legged robot will start to follow you. Immediately reverse directions and head back to the right. The robot will follow you. Keep going until you pass through the flashing circular door. The robot will have given up following you and gone back to the escape pods (You can verify this by going back through the circular door and seeing that the robot is no longer there). Continue going in the same direction (to the right) about another six screens until you once again reach the escape pods. You will have won the footrace with the robot.

Hallway (Escape Pods)

Push button. Enter pod (10 points). Look pod. Look control panel. Push launch button. The countdown begins. You are launched into space.

Floating in Space

Suddenly a warning signal draws your attention to the oxygen meter on the front panel. It reads low and is dropping fast. You have, maybe, five minutes of air left. Look pod. (You see a sleep chamber against one wall). Move to the rear right and: Open Chamber. Enter chamber. Soon you drift away into a deep sleep with the satisfaction of having accomplished your task (10 points).

Star Trek: The Promethean Prophecy

- take the holo
- examine the holo (it's a glass hemisphere about the size of an egg that shows its full effect when shaken - inside it is a holographic image of your lost love Cortneelia)
- shake the holo (Cortneelia blows you a kiss - Berryman informs you that he has scanned a Class M planet - Prometheus Four)
- ask Berryman about the planet
- look at Berryman (Sulu informs you of something massive in the immediate vicinity)
- look at the viewscreen (Sulu informs you that the ship has been hit by an unidentified attacker)
- Sulu, analyze the attacker
- Berryman, analyze the attacker
- look at the navigator's station (it contains among other things, an intercom)
- Kirk to Spock (Spock informs you that he is on the way)
- Sulu, describe the damage (Spock arrives and takes over the command from Berryman)
- Spock, analyze the attacker (Spock describes the attacker as a Romulan bird of prey)
- Spock, analyze the bird of prey (Uhura asks if she should put communication from the Romulan vessel on the screen)
- yes (the Romulan commander appears on the screen but does not communicate with you - Spock talks about an image mirroring the movements of the adversary)
- Spock, analyze the image
- Sulu, arm the photon torpedos
- lock the torpedos on the image
- fire the torpedos at the image (repeat until the bird of prey is scorched and inert. Uhura again asks if you want her to put a communication from the vessel on the screen)
- yes (the Romulan warship commander explains the reason for the attack, admits defeat, and then proceeds to pull a lever and blow up his ship)
- Spock, describe the damage (you learn that the leaking phaser coolants have contaminated the food supply aboard the Enterprise. Spock suggests that a small landing party go down to Prometheus Four and search for food)
- Sulu, describe the damage
- Kirk to Scotty
- Scotty, describe the damage
- s (you are on deck one of the turbolift - you learn that only decks one, five, and seven are functional)
- d
- d
- n
- n
- take the phaser and the communicator and the tricorder (Spock will take the tricorder from you)
- get on the transporter
- energize (you wind up in a sandy clearing)

on the planet Prometheus Four)
examine the obelisk
examine the pictogram (it's a series of five dashes following an asterisk)
w
Spock, scan the boulders (below, under the rocks, lies an artifact of unknown origin. Also, there exists evidence that when the boulders fell, approximately twelve humanoids were crushed and buried alive)
e
s
examine the lizard
wait (the lizard drops a gold sphere on the ground)
take the sphere
n
n
n (you encounter a grotesque humanoid creature - she drops a glossy tablet at your feet and then disappears)
take the tablet
examine the tablet (the symbol on it is the same as that on the obelisk)
n
w
w
nw
nw
n (you meet up with the Fool)
examine the fool (note that his eyes are opaque grey like steel marbles - he suggests that if you get to know him the steel would drain from his eyes. He is quite unlike the other Prometheans you have already met. In fact he is the

Afflictor mentioned by one of the female humanoids you previously encountered)
wait (the Fool tells you that what you seek can be found at the desert's edge)
n
se
se
w
examine the table (on it is a pictogram - also note that it is attached to the wall by a glass-blend hinge)
examine the pictogram (it resembles those you previously saw on the obelisk and tablet except that the 5 dash pattern is now bent)
turn on the communicator (assuming it whistles - it's Uhura telling you that Starfleet Command has responded to the distress call)
take the strand
examine the strand
set the phaser to narrow beam
fire the phaser at the hinge (it cuts through it)
give all to Spock
take the table
e
put the table on the quicksand
s
wait (a voice asks you to show the sign of your intentions - what is meant is make the symbol on the tablet the same as the one on the table)
break the tablet (a staircase leading up is

revealed)
u (Gildea, the Defender who gave you the
tablet, reveals herself)
wait (repeat while Gildea tells her story.
Finally, she will present you with a red
gem)
d
n
nw
d
s
take all (from Spock)
turn on the communicator (assuming it
whistles)
s
s
se
e
e
s
s
s
s (back at the edge of the desert - you
notice that the terrain has changed from
barren sand to thick green vegetation -
a polyp about the size of a human fist
falls to the ground)
take the polyp (the fruits and vines are
fakes - it's the work of the Fool -
suddenly the soil is being cracked from
underneath by burrowers coming from
all different directions)
Spock, analyze the polyp (he verifies that it
is indeed a fake made to resemble
edible material - a decoy to lure you
into the trap you are already in)
set the phaser to wide beam

fire the phaser at the burrowers (repeat
until a ribbed sphere is dislodged from
the sand)
take the ribbed sphere
fire the phaser at the burrowers (repeat
until a violet sphere appears in the
sand)
take the violet sphere
nw
Spock, analyze the cave (he gives you a
similar analysis to that which you got at
the rock slide - you must be right under
it - something of interest must be in that
pile of boulders)
set the phaser to overload
drop the phaser
se
nw
take the rod
Spock, analyze the rod (it's a fragment of a
musical instrument)
turn on the communicator (in the middle of
Sulu's communication, a Defender
wrenches the device from your hand
and proceeds to crush it under his foot.
Hold on to the broken communicator.
You'll need it later)
e
n
n
n
e
e
ne (outside the yellow gate - you meet up
with a Trader named Weelomin)
give the holo to Weelomin (in return, he
offers you a yellow gem, the symbol of

the Trader world. It will get you in any place the Traders go)
show the yellow gem to the guard (you pass through the yellow gate and into the Bazaar of the Traders)
give the rod to the trader (he will offer you some item in exchange. If it's a small sphere then stop trading. If not, trade the item he just gave you for something else. Continue trading with him until you get the small sphere - it should only take a few trades. Don't trade the yellow gem with him since you need to show this to the guard each time you want to get into the bazaar)

e

wait (repeat until the sandstorm is headed your way - it occurs about 100 or so moves after you land on Prometheus Four which should be about now. When this happens you must be near a place of shelter in the compound else you will die. At the first sight of the sandstorm, the guard will run into the compound and thus you can now pass into the bazaar without showing the yellow gem)

w

wait (until the sandstorm is over - you will once again be outside the yellow gate)

sw

w

w

w

w

nw

e (had you arrived here during a sand-

storm, you would not have been able to enter)

enter the pod (three Delighters are busy mumbling, smiling, and spinning in circles about a shaft of light and are unaware of your presence - the fourth one introduces himself as Gaidren. The movements of the Delighters are supposed to remind you of the planets orbiting around the sun. This is suggested by Kirk in the prelude to the game when he is reminiscing about the models hung from the ceiling in his room at the Academy - gleaming spheres, circling endlessly in the darkness, which look like toys,

The present model of the solar system composed of only Delighters is incomplete. Use the spheres you've collected to complete it)

put gold sphere in shaft (you've now added the sun)

give violet (or ribbed or small) sphere to Delighter

mumbling (or smiling or spinning)

give ribbed (or violet or small) sphere to Delighter

smiling (or mumbling or spinning)

give small (or ribbed or violet) sphere to Delighter

spinning (or smiling or mumbling.

Gaidren suddenly becomes aware of what you have completed and its relation to the purpose of the Delighters. He gives you a violet gem and leaves)

take all

leave the pod

w

se

e

e

e

e

ne

give ribbed sphere to Weelomin (in return he gives you an item. Trade with him until he gives you a forked thing)

examine the forked thing (it's a Y-shaped piece of glass-blend material whose purpose is obscure)

ne

n

w

put forked thing in crevice

put strand on forked thing

d

take the tarpaulin

take all (the forked thing and the knotted strand)

u

e

s

sw

give violet sphere to Weelomin (in return he gives you a glass-blend statue of an animal)

show yellow gem to guard (you are once again in the Bazaar)

give the strand to the trader (in return you get a ragged blue robe)

give the robe to McCoy (needless to say, he's not too pleased with it)

give the statue to the trader (in return you

get a new robe)

give the robe to Dimas (it's quite befitting for a female)

give forked thing to the trader (in return you get a top quality harrik brush)

e

give the brush to Weelomin (just the thing he needs since he is always standing outside the gate in wind and sand - in return he gives you a wrinkled blue robe)

give the robe to Spock (now everyone in your landing party but yourself has been fitted with a robe)

ne

examine the bowl (it's big enough for the entire landing party to get on it at the same time)

enter the bowl

put the tarpaulin on the bowl (after a long minute hiding in the covered bowl, a Promethean with a broom comes along and calls out to others to join him. The group forms a work team and pulls the cart through traffic to the Enclave of the Sustainers. As you exit the cart, you are greeted by Jharpe)

show the communicator to Jharpe (Jharpe, in his own way, describes the electronic circuitry inside the communicator. Suddenly, in the hands of Jharpe, the communicator's grid flips open and you hear a communication from Scott giving you a progress report. In the middle of the report, the speaker goes dead. After some more dialogue, Jharpe gives you back the communica-

tor along with a green gem)
e
take the box
examine the box
open the box (surprise! it's a Promethean
jack-in-the box)
w
ne
s
s
s
give the box to Weelomin (he gets very
excited and calls for his son Biphlomin
who trades his embroidered robe for the
box. Weelomin gives you the robe.
This one's for you!)
wear the embroidered robe
show the yellow gem to the guard (once
again in the bazaar)
give gold sphere to the trader (keep trading
until you get back your ornamented
rod)
put violet gem on the rod (it clicks in place
on the tip)
put yellow gem on the rod
put red gem on the rod
put green gem on the rod
e
sw
w
w (a public procession is in progress)
examine the procession (it's a line of
Chanters)
join the procession (the procession moves
through a short tunnel and winds up at
the Cloister of the Chanters. Among
the Chanters there, is a smiling woman

named Daia who leads you and your
party to the side of the courtyard)
spin the rod (Daia spins the rod again and
is excited at having found the chord of
the Commanders after so many years.
Identifying you as Captain Kirk, she
gives you the final item you need, the
blue gem)
put the blue gem on the rod
spin the rod (as it spins, the chords of each
gem in the rod blend in a complex
harmony. The Prometheans outside the
compound hear the music and come
pouring in the blue gate. The Defend-
ers do not attempt to block the Prom-
etheans and themselves join the throng.
They cry, "The Seed! The Seed has
been roused!" referring to a mound in
the center of the courtyard. The central
portal rises open disgorging the figure
of the Fool. McCoy suddenly puts it all
together and recognizes that the Fool is
indeed the feared Afflictor)
give the rod to the Fool (a beam of flame
leaps out of it arcing over to the mound
which now puffs outward in all
directions. When it reaches five times
its normal size it stops growing finally
taking the form of a giant saucer with a
gap the size of a doorway - it's a
spacecraft! The Prometheans load up
their spaceship and offer to escort you
back to yours - you wind up back on
the bridge of the Enterprise with all the
food stuffs you and your crew need.
Congratulations, you have won the
game)

Talisman

wait (5 times - the cell door opens - you are taken to the execution block upon which you are rescued and brought before King Darius)	w
bow (or kneel - you learn of your mission from the King who gives you a bag of 50 gold coins and a companion Abu)	n
w	w
s	s (on the dilapidated bridge)
s	wait (a bottle appears in the river. Repeat until the bottle flows downstream and disappears under the bridge)
w (in Hosni's tent)	look under the bridge
read the sign	take the bottle
talk to Hosni	examine the bottle (it's sealed with a cork)
buy flask	s
offer 10 (that's the minimum offer he will consider)	s
offer 13 (continue to increase your offer in increments of 3 gold coins until Hosni accepts)	s
e	e
e	fill the flask with water
read the board (repeat a few times - there are three different messages posted)	drink the water
e	s
examine the trinkets	take the log
buy the diamond (or any of the other trinkets - you are refused your purchase - instead you are offered for sale a 24 carot ring for 20 gold coins. You are asked if you want it)	n
yes	jump east
w	examine the dam (note the wooden torch - it's lodged in the dam construction and cannot be taken)
	jump west
	n
	drop the log into the river
	s (the log, propelled by the current, breaks apart the dam freeing the torch)
	s
	e
	take the torch
	e

d
examine the statues
take the shield
examine the cup
drink the nectar
u
u
take the rods (pearl, nickel, jade,
emerald, and onyx)
d
e
s
s
e
talk to the villagers (repeat until a drunk
tells you that, before his execution,
he stashed a catalog behind the wall
of the King's prison cell)
w
n
e (you see a rabbit in the meadow)
lure the rabbit with the ring
take the rabbit
w
n
e
put the onyx rod in hole 1
put the pearl rod in hole 2
put the emerald rod in hole 3
put the nickel rod in hole 4 (note that
the first letters of each of the rods,
i.e., (o)nyx, (p)earl, (e)merald,
(n)ickel form the word: OPEN)
push the button
e
take the lamp
w

w
w
d
play the lyre (you are teleported back to
the courtyard)
w
ask the executioner to unlock the cell
n
examine the bricks
push the brick
reach into the chamber
take the booklet
examine the booklet (it's a catalog)
read the catalog (it contains an ordering
card)
s
e
s
s
e
s
s
e (at brink of deep pit)
drop the rabbit into the pit (the lion at
the bottom of the pit presumably
makes a meal of the rabbit)
d (surprise!)
examine the debris
take the shard
take the gold
u
w
n
n
w
w (in Hosni's tent)
buy the rope

offer 10 (continue to increase your offer
in increments of 3 gold coins until
Hosni accepts)

e

n

w

s

s

w (in a small shop)

talk to the clerk

give the ordering card to the clerk (he
asks for the first two letters of the
product number of your choice -
you want to buy an economy
carpet; so, using the information in
Muhammad's Market (which came
with the game), answer as follows)

CP (he now asks you for the 5-digit
code that follows it)

65011 (he offers you the deluxe model
carpet instead. He asks you for
your Arabian Express charge card
number. Again consult the card
that came with your game for this
information)

RJ8906 TA3756 (you will receive what
you ordered later on in the game)

e

s

s

s

e

e

e

s

s

w (at the bandits)

kill the bandits

w

s

throw the rope

climb down the rope

grab the rope

swing into the cave

e

light the lamp with the flint

e

rub the lamp (the genie is sucked into
the lamp)

blow out the lamp

talk to the magician (he tells you to seek
an ancient Talisman who has the
powers to set him free. He asks if
you will do this)

yes (he gives you a magic spell: "open
sesame")

w

w

wait (repeat until thy rope is swinging
toward the cave)

jump

n

e

e

n

n

w

w

w

w

n

n

n

n

w

w (at the base of the waterfall)

open sesame (a doorway opens in the waterfall)

enter the waterfall

w

w

twist the cork (on the bottle containing the miniature ship)

fill the bottle with water (the ship grows to full size as it smashes through the bottle)

enter the ship (you depart the Persian Empire and are now in the Land Beyond section of the game)

wait (repeat until a thunderstorm breaks the boat's mast which falls on you and knocks you unconscious.

Continue waiting until you wake up on the beach of a vast desert. This is a good place to save the game)

w (you are in a desert maze. It is a "moving" maze so it can't be mapped. Wander about in random directions and you will eventually stumble on an oasis)

fill the flask with water

drink the water

examine the tree (there is a cluster of figs within your reach)

take the figs (as you approach the tree, a snake appears hanging from a branch)

tell Abu to kill the snake

take the figs (continue to wander randomly in the desert. You will eventually come across a camel

roaming the sands)

examine the camel (it has a cylinder around its neck)

feed the fig to the camel

open the cylinder

look inside the cylinder (the carpet that you previously purchased in the small shop in the Empire section of the game should be there)

take the carpet (continue to wander randomly in the desert. You will eventually come to a statue)

talk to the parrot (repeat until it tells you it wants some water)

give water to the parrot (it flies down for your offering. As it does so, it knocks the staff out of the statue's left hand)

take the staff

examine the pedestal (it has an inscription and a small hole below it)

read the inscription

put the staff in the hole (an entrance into the statue opens up)

enter the statue

light the torch

n (you are now in the upper underground pit which is a 4 x 3 grid of rooms. Below that is the lower underground pit which is a 3 x 2 grid of rooms. For simplicity of notation, we shall denote these rooms by their X,Y coordinates followed by either U (for upper) or L (for lower). The room you are in now is 2,1U. The walls in the

rooms on the upper level change as you move about from room to room. (The walls in the rooms on the lower level remain fixed.)

Thus, when you leave a given room and then reenter it later on, the possible exits will undoubtedly have changed. To stop them from changing, you must have Abu pull the metal lever in room 1,1L (i.e., the southwest corner of the lower underground pit.) To get there, first make your way to room 4,3U. Then go down (into the hole) to the lower pit. Make your way to room 1,1L)

tell Abu to pull the lever (this stops the walls from changing. Now make your way to room 1,1U pulling the appropriate levers to open the walls (see the map for which levers control which walls) that will allow you to get there. This must be done somewhat by trial and error since the positions of the walls, after the lever is pulled, is random depending on their initial state when you entered the pit and how many moves it took you to get to this room)

look inside the bowl

take the Talisman (this upsets the balance of the bowl and dome being held by the demon thus closing the only exit (north) from this room. You must put an appropriate amount of weight back

in the bowl to rebalance the "demon scale". By trial and error, it can be found that 42 gold coins are necessary.

put 42 gold coins in the bowl (the scale should now be balanced and you can now exit this room to the north. You must now proceed to get out of the statue as quickly as possible. (This is a good place to save the game.) As you head toward the entrance to the statue, you will find that the only possible exit (between rooms 2,2U and 2,1U) is blocked by a wall. Since this wall is not controlled by a lever, to get it to open, you must once again set the walls in motion, i.e., go back to room 1,1L and have Abu pull the lever. The following sequence will get you out of the statue in time before it crumbles.) Note: if you wear the Talisman, you will find that the screens will appear upside-down. To restore them to their normal appearance, just remove the Talisman)

n

e

e

e

n

d

s

w

w (you should be back in room 1,1L)

tell Abu to pull the lever

n
e
pull the lever
s
e
pull the long lever
n
pull the lever
u
s
w
w
s
s (you should now be outside the statue)
drop the carpet
sit on the carpet
fly the carpet
wait (repeat until you wind up back on
the lip of the wide tunnel)
stand up
e (this is a good place to save the game)
e
give the Talisman to the magician (he
will, on the next move, begin to
recite a mantra — the first letters of
the words in the mantra, when
linked together, form the phrase:
POUR WATER ON THE LAMP.
Don't wait for him to finish reciting
the mantra. Just proceed as
follows)
pour water on the lamp
rub the lamp (the genie reappears. Your
wish is his command)
tell the genie to kill the magician (he
asks if you will, in return, grant his
freedom)

yes (he proceeds to envelop the magi-
cian in smoke and put him inside
the lamp)
take the lamp
w
w
sit on the carpet
fly the carpet
wait (the dipping and diving of the
carpet knocks the lamp out of
Abu's hands. You watch it
plummet and then hit the water as
the magician's prison now slowly
sinks to the bottom of the ocean)
wait (the carpet descends and you arrive
in front of the King's fortress)
stand up
n
e
bow (you are congratulated by the King
for your heroic efforts)

Twilight's Ransom

The game starts at 7:00 p.m. and you have 12 hours to sunrise to rescue Maria Chavez. Certain key locations close at specific times (e.g., the library closes at 9:30 p.m.). Thus, you must plan your strategy to get there and find what is important before closing time. There are many locations in the game but only relatively few of them have any significance. Also there are many items you will find, e.g., Maria's purse, that are "red herrings", i.e., they play no significant part in the game. The subway system is there merely for transporting you from point to point in Liberty City without having to move through the streets. There is nothing of significance in the subway so you really never need to use it. And now for the step-by-step solution.

u (or w)

w

read the note (the Spanish words are the days of the week. The letters next to these words will have significance shortly as will the letters and numbers on the back of the note)

e (Maria's phone is ringing)

answer the phone (you are told to bring what Maria's abductors want to the EastCo. warehouse north of Bond Street and Stallion Road before sunrise)

d (or e)

e

n

n

n

n

e

open the mailbox

take the pink envelope

open the pink envelope

read the note (it's from Maria)

read the documents (they are receipts of over a dozen Telex transactions transferring money between bank accounts in the Grand Kaymen

Islands - YOU HAVE FOUND THE FIRST OF THE THREE SETS OF DOCUMENTS HIDDEN BY MARIA WHICH YOU NEED TO DELIVER TO THE EASTCO WAREHOUSE)

w

s

w

s

s

look under the Ford

take the bolt cutters

n

n

w

w

w

n

w

w

n

ne (in the alley)

drop the pink envelope

put the trash can under the awning

climb on the trash can

put the bolt cutter on the awning

climb on the awning
 take the bolt cutter
 open the window
 w
 s
 take the chalk (it will come in handy in the
 sewers)
 n
 n
 examine the files
 open the folder
 look for Maria's locker number (it changes
 each time you play the game)
 s
 cut the lock on XXX with the bolt cutter
 ("XXX" is the number of Maria's
 locker you found in the folder)
 open locker XXX (inside it is a grammar
 textbook, a manilla envelope, and a
 Panama hat)
 open the textbook (it contains a map)
 take the map and the hat
 read the map (the letters you found on the
 note on Maria's bulletin board
 are the first letters of the colors of
 the circles around the locations of
 the
 map)
 wear the hat
 drop the bolt cutter
 take the envelope
 open the envelope (inside it are some
 sheets of paper)
 read the sheets of paper (they are docu-
 ments representing an inventory
 taken from an accounting ledger -
 YOU HAVE FOUND THE SEC-
 OND OF THE THREE SETS OF
 DOCUMENTS HIDDEN BY
 MARIA WHICH YOU NEED

TO DELIVER TO THE EASTCO
 WAREHOUSE)

e
 d
 take the pink envelope
 s
 s
 w
 w
 s
 s
 s
 look for PS 3511 I-912 t29 (remember the
 letters and numbers on the back of
 the note you found in Maria's
 kitchen on the corkboard. The book
 is missing from the shelf)
 n
 ask the librarian about PS 3511 I-912 t29
 (she tells you it was checked out
 today)
 wait (repeat until the phone rings and the
 librarian goes to answer it leaving
 the card on the desk)
 take the card
 read the index card (it reads: June Clenon-
 don, 178 Townshed, 12-4-87.
 Perhaps you should find where in
 Liberty City this is and go there.
 Before that you might want to give
 consideration to losing the guy in
 the suede jacket who's been
 following you around. It is impor-
 tant to do this since eventually he
 will catch up with you and kill you.
 You will need to go into the sewer
 (the entrance is down through the
 manhole cover on the corner of
 Bond Street and Kennedy Street)
 and lead him through

the system before exiting on the corner of Bond Street and Townshed Road. Before entering there you will need a source of light, e.g., a flashlight)

n

n

w

w

w

w

s

e

take the flashlight

w

n

e

e

e

e

e

e

e

e

e (at Kennedy Street and Bond Street - there is a hole in the ground with a manhole cover lying next to it)

d

turn on the flashlight (to map the sewer maze, you can mark the walls in the rooms (but not the intersections) with the chalk. For example, a suitable command might be: write "1" on the wall)

ne

ne

e (you are at an intersection)

turn off the flashlight (because you are at an intersection where the direc-

tions are marked, you can move to another location in the dark)

n

turn on the flashlight (you have been successful in losing the guy in the suede jacket)

w

e

u

open the crate (it is filled with AK-47 combat rifles, completely assembled except for the ammunition clip)

d

n

s

n (there is a steel ladder here by which you escape the sewer system)

u

turn off the flashlight (conserve energy)
drop the flashlight

e

ne

n

w

s

read the menu
buy the big burger
buy the junior burger

n

w

s

w

s (on the front porch of the Clenondon house)

uproot the yucca cane (a rolled piece of cotton cloth falls at your feet)

open the cloth (in it is a house key)

take the key

unlock the door (with the house key)

s

give the junior burger to the dog (it takes the burger in its mouth and runs off into the kitchen)

s

open the library book

take the ticket (the dog has returned and is blocking the bedroom doorway.

Good thing you brought along two burgers)

give the big burger to the dog (again it takes the burger and runs off into the kitchen)

n

n

n

w

w

w

n

w

w

w

w

w

w

w

s (in the pawn shop)

give the ticket to the man (he brings out a bust of Simon Bolivar (like the one you gave Maria and saw smashed in her apartment) and sets it on the display case)

take the bust

break the bust (repeat until it shatters and you see a bundle of documents lying amidst the shards)

take the bundle

read the bundle (they are balance sheets from an accounts ledger. YOU HAVE FOUND THE THIRD OF

THE THREE SETS OF DOCUMENTS HIDDEN BY MARIA WHICH YOU NEED TO DELIVER TO THE EASTCO WAREHOUSE)

n

e

e

e

e

e

e

e

n

n

n

n

n

e

s

e

n

n (in the EastCo warehouse)

show the sheets of paper to the thin man

show the multiple page document to the thin man

show the bundle of documents to the thin man (he senses your distrust and tells you that as a gesture of good faith he is moving Maria Chavez to the transfer location (which you must now find). He then dials the phone and orders the transfer.

Ramon takes over and points a pistol at your chest)

hit Ramon with the crowbar (his gun is knocked from his hand and lands under a pallet supporting two crates. Ramon recovers and comes at you)

hit Ramon with the crowbar (he crumbles to the floor)

get on the forklift
turn on the forklift
move the pallet with the forklift
turn off the forklift
get off the forklift
take all but the crowbar

s

s

w

s

s

s

s

s

s

w

n

n

n

w

w

n

w (entrance to Adonis Health Club)

tell the man about the rifles (he escorts
you into the weight training room
where you meet the Tan Man. He
asks about your involvement with
the rifles)

tell the Tan Man about the rifles (he tells
you he is willing to trade for the
location of the rifles, that is, if you
can find them. What he means is
that he wants you to locate them
but not from within the sewers but
from outside. Thus, you must go
back into the sewers and somehow
mark the small warehouse so that it
can be identified from the outside.
Perhaps you can float a balloon or
two in the skylight of the small

warehouse)

e

e

drop all (you will be robbed in the park so
it is better to leave everything here
for the time being)

n

n

nw

untie the balloon (you also take it)

se

s

s

take all

s

e

e

s

w

untie the red balloon (you also take it)

e

s

s

e

e

e

e

drop all but the blue balloon and the red
balloon

take the flashlight

d

turn on the flashlight

se

w

e

u

take the rifle

tie the red balloon to the blue balloon

tie the blue balloon to the rifle

put the rifle under the skylight (the red

balloon passes through the open skylight and hovers a few feet above the building)

d
n
s
n
u

turn off the flashlight
drop the flashlight
take all but the flashlight

w
w
w
w
n
w
w
w
w
w

n in front of an old run down building - a red balloon is blowing a few feet above the building in the wind. Congratulations! you have found the location of the rifles. Now go back and give this information to the Tan Man)

read the sign (this building is "Spiney's garage")

s
e
e
e
n
n
w

w (the Tan Man is sitting on the floor here)
tell the Tan Man that the rifles are in Spiney's garage (Sal and Freddy

check out your information and find it to be valid. The Tan Man now agrees to fill his end of the deal. He tells you that you should go to the El Diablenight club to get information about the whereabouts of Maria. The bulky man shows you out of the Health club)

e
s
e
e
s
s
s
e
e
e
e
e
ne

n
e
s
give 5 dollars to the bouncer
s
se
e
e

stand on the toilet
remove the ceiling tile

w
close the stall door (so that the removed ceiling tile will not be noticed by anyone visiting the restroom)
w

nw (the thin man makes his way through the crowd into the open area and enters the brown door)

wait (repeat until the thin man leaves the room he was in and enters the restroom. Continue to "wait" until he leaves the restroom and returns to the room behind the brown panel door).

se

e (you hear voices through the hole in the ceiling telling you that Maria has been moved to the South Tempest Street boat house. Continue to "wait" until you hear that the meeting is adjourned. Then get out of there in a hurry).

w

nw

n

n

w

s

sw

w

s

w

w

s (a Honda is parked at the top of the hill)

open the door

release the brake

w

sw

n (inside the boathouse, you see Maria tied up and gagged)

shoot the bald man with the gun

untie Maria

s

untie the yellow boat

start the yellow boat (it heads off across the Tempest river - this prevents anyone from jumping in this boat and heading off after you)

get in the maroon boat (a black man runs onto the pier and aims his rifle at you when suddenly he is knocked out compliments of the Tan Man)

untie the maroon boat

start the maroon boat (the black man comes to and tries to shoot you again but by now you are too far away from the pier. Maria and you deliver the documents to the FBI resulting in the arrest of Melendez and his cronies, and the eventual grand jury indictments of a number of public officials on bribery charges. The remainder of the story unfolds before your eyes. Then enjoy the nice graphic ending)

Vendors

Artworx Software Co., Inc.

1844 Penfield Rd.
Penfield, NY 14526
(716)385-1603
GrailQuest

Addison-Wesley General Publishing Corp.

Jacob Way
Reading, MA 01867
(617)944-3700
The Shadows of Mordor

Baudville, Inc.

1001 Medical Park Dr., S.E.
Grand Rapids, MI 49506
Dream Zone

Datasoft Inc.

19808 Nordhoff Place
Chatsworth, CA 91311
(818)886-5922
Dark Lord

First Row Software Publishing Inc.

900 E. 8th Avenue, Suite 300
King of Prussia, PA 19406
(215)337-1500
Dr. Dumont's Wild P.A.R.T.I

ICOM Simulations, Inc.

648 S. Wheeling Road
Wheeling, IL 60090
(312)520-4440
Deja Vu II: Lost in Las Vegas

Infocom, Inc.

A Division of Mediagenic, Inc.
125 Cambridge Park Drive
Cambridge, MA 02140
(617)492-6000
Beyond Zork, Border Zone, Plundered Hearts, Sherlock Holmes: The Riddle of the Crown Jewels

Mastertronic International, Inc.

711 West 17th Street, Unit G9
Costas Mesa, CA 92627
(714)631-1001
Demon's Forge

Microillusions

17408 Chatsworth St.
Granada Hills, CA 91344
(818)360-1464
Dondra: A New Beginning

Paragon Software

600 Rugh Street
Greesburg, PA 15601
(412)838-1166
Twilight's Ransom

Polarware, Inc.

1055 Paramount Parkway, Suite A

Batavia, IL 60510

(312)232-1984

Talisman

Rainbird Software

P.O. Box 2227

Menlo Park, NJ 94026

Guild of Thieves, Jinxter, Knight Orc

Sierra On-Line, Inc.

P.O. Box 485

Coarsegold, CA 93614

(209)683-6858

King's Quest III: To Heir is Human,

Leisure Suit Larry: The Land of the

Lounge Lizards, Police Quest, Space Quest

II: Vohaul's Revenge

Simon and Schuster

1230 Avenue of the Americas

New York, NY 10020

(212)245-6400

Star Trek: The Promethean Prophecy

Are you stuck, stumped, stymied on how to bypass the wildebeest, win the kite races, or escape from the spell of the evil King Manannan? These are some of the more perplexing puzzles encountered in solving the most recent computer games.

Sometimes even the most adept games player needs a helping hand. *Hints, Maps, and Solutions to Computer Adventure Games* provides that help for 22 of the most popular games.

Here's what you'll find inside:

- 📖 Complete maps for all 22 games
- 📖 Hints and clues, most of which cannot be found anywhere else
- 📖 A unique scrambling technique providing more than 900 hints, yet preventing you from glimpsing any clue other than the one you're looking for
- 📖 Complete, step-by-step solutions when you're ready to "throw in the towel"

Marvin K. Simon is an avid adventure game player who has personally solved each of the adventures included in this book. He has written two previous adventure games books: *Keys to Solving Computer Adventure Games I and II*.

Games included are:

Beyond Zork
Border Zone
Dark Lord
Deja Vu II
Demon's Forge
Dondra
Dr. Dumont's Wild P.A.R.T.I.
Dream Zone
Grail Quest
Guild of Thieves
Jinxter
King's Quest III
Knight Orc
Leisure Suit Larry
Plundered Hearts
Police Quest
Shadows of Mordor
Sherlock Holmes
Space Quest II
Star Trek
Talisman
Twilight's Ransom

\$16.95

Higher in Canada

ISBN 0-87455-220-6



9 780874 552201

COMPUTE! Books
Radnor, Pennsylvania